

# OMRON

## Multi-function Compact Inverter

# M1 Series Standard Type

## User's Manual

3G3M1-A□□□□



I669-E1-03

#### **NOTE**

1. All rights reserved. No part of this publication may be reproduced, stored in a retrieval system, or transmitted, in any form, or by any means, mechanical, electronic, photocopying, recording, or otherwise, without the prior written permission of OMRON.
2. No patent liability is assumed with respect to the use of the information contained herein. Moreover, because OMRON is constantly striving to improve its high-quality products, the information contained in this manual is subject to change without notice.
3. Every precaution has been taken in the preparation of this manual. Nevertheless, OMRON assumes no responsibility for errors or omissions. Neither is any liability assumed for damages resulting from the use of the information contained in this publication.

#### **Trademarks**

- Sysmac and SYSMAC are trademarks or registered trademarks of OMRON Corporation in Japan and other countries for OMRON factory automation products.
- Microsoft, Windows, Excel, Visual Basic, and Microsoft Edge are either registered trademarks or trademarks of Microsoft Corporation in the United States and other countries.
- EtherCAT® is registered trademark and patented technology, licensed by Beckhoff Automation GmbH, Germany.
- ODVA, CIP, CompoNet, DeviceNet, and EtherNet/IP are trademarks of ODVA.

Other company names and product names in this document are the trademarks or registered trademarks of their respective companies.

#### **Copyrights**

- Microsoft product screen shots reprinted with permission from Microsoft Corporation.

# Introduction

---

Thank you for purchasing the Multi-function Compact Inverter 3G3M1 Series.

This User's Manual describes the installation/wiring of the 3G3M1 Series Inverter, and parameter setting method which is required for the operation, as well as troubleshooting and inspection methods.

## Intended Readers

This manual is intended for the following personnel.

Those who have knowledge of electrical systems (an electrical engineer or the equivalent) and also are qualified for one of the following:

- Personnel in charge of introducing the control equipment
- Personnel in charge of designing the control systems
- Personnel in charge of installing and maintaining the control equipment
- Personnel in charge of managing the control systems and facilities

## Notice

This manual contains information you need to know to correctly use the Multi-function Compact Inverter 3G3M1 Series.

Before using the inverter, read this manual and gain a full understanding of the information provided herein.

After you finished reading this manual, keep it in a convenient place so that it can be referenced at any time.

Make sure this manual is delivered to the end user.

# Manual Configuration

This manual is compiled section by section for user's convenience as follows.

Section		Overview
Section 1	Overview	This section provides an overview of the 3G3M1 Series features, standard specifications, and external dimensions by inverter capacity. It also shows the differences of this inverter from conventional inverters for those who use previous models.
Section 2	Design	This section describes the installation environment and wiring methods.
Section 3	Operation and Test Run	This section describes the part names and key operations of the Operator, and the operation method of this product as well as the test run procedure.
Section 4	Parameter List	This section provides the parameter lists that show monitor functions and available parameters for this inverter.
Section 5	Basic Settings	This section describes the basic functions such as the Run command.
Section 6	Vector Control and Applied Functions	This section describes the vector control and applied functions characteristic of this inverter.
Section 7	Other Functions	This section describes the details of functions not described in Section 5 or Section 6.
Section 8	Communications Function	This section describes the general-purpose serial communications functions (Modbus communication).
Section 9	Troubleshooting	This section describes how to analyze the cause and take countermeasures if the inverter fails, and provides troubleshooting for possible troubles.
Section 10	Maintenance and Inspection	This section describes the maintenance and periodical inspection items.
Appendix		This section provides information on derating, capacitor life curve, compliance with the UL/cUL Standards, and inverter selection.

# Manual Structure

## Page Structure and Symbol Icons

The following page structure and symbol icons are used in this manual.

**Level 1 heading** — 2 Design

**Level 2 heading** — **2-2 Removal of Each Part**

**Level 3 heading** — **2-2-1 Removing Covers**

**Section Number of Level 1 heading** — Shows which section the content of the current page belongs to.

**Section Number of Level 2 heading** — Shows which paragraph the content of the current page belongs to.

**Section Number of Level 3 heading** — Shows which paragraph the content of the current page belongs to.

**Operation Steps** — Describes the operation steps.

**Note, Supplementary Information, Reference Target** — A note, supplementary information, reference target, etc. are provided with difference icons.

**Manual Name** — 3G3M1 Standard Type User's Manual #669E1-01

Note: The above page is only a sample for illustrative purposes. It is not the actual content of the manual.

## Special Information

Special information in this manual is classified as follows:



### Precautions for Safe Use

Precautions on what to do and what not to do to ensure safe usage of the product.



### Precautions for Correct Use

Precautions on what to do and what not to do to ensure proper operation and performance.



### **Additional Information**

---

Additional information to read as required.

This information is provided to increase understanding or make operation easier.

---



References are provided to more detailed or related information.

# Sections in this Manual

---

<b>1</b>	<b>Overview</b>	<b>10</b>	<b>Maintenance and Inspection</b>	<b>1</b>	<b>10</b>
<b>2</b>	<b>Design</b>	<b>A</b>	<b>Appendix</b>	<b>2</b>	<b>A</b>
<b>3</b>	<b>Operation and Test Run</b>			<b>3</b>	
<b>4</b>	<b>Parameter List</b>			<b>4</b>	
<b>5</b>	<b>Basic Settings</b>			<b>5</b>	
<b>6</b>	<b>Vector Control and Applied Functions</b>			<b>6</b>	
<b>7</b>	<b>Other Functions</b>			<b>7</b>	
<b>8</b>	<b>Communications Functions</b>			<b>8</b>	
<b>9</b>	<b>Troubleshooting</b>			<b>9</b>	

# CONTENTS

---

<b>Introduction .....</b>	<b>1</b>
Intended Readers .....	1
Notice .....	1
<b>Manual Configuration .....</b>	<b>2</b>
<b>Manual Structure.....</b>	<b>3</b>
Page Structure and Symbol Icons .....	3
Special Information .....	3
<b>Sections in this Manual .....</b>	<b>5</b>
<b>Terms and Conditions Agreement.....</b>	<b>13</b>
Warranty, Limitations of Liability .....	13
Application Considerations .....	14
Disclaimers .....	14
Statement of security responsibilities for assumed use cases and against threats .....	15
<b>Safety Precautions.....</b>	<b>16</b>
Indications and Meanings of Safety Information .....	16
Meanings of Signal Words .....	16
Explanation of Symbols .....	16
<b>Precautions for Safe Use .....</b>	<b>23</b>
Installation and Storage .....	23
Transportation, Installation, and Wiring .....	23
Operation and Adjustment .....	23
Maintenance and Inspection .....	24
<b>Precautions for Correct Use .....</b>	<b>25</b>
Maintenance and Parts Replacement.....	25
Product Disposal.....	25
Warning Label.....	25
Warning Description.....	26
<b>Regulations and Standards .....</b>	<b>27</b>
<b>Items to Check after Unpacking .....</b>	<b>28</b>
Checking the Nameplate .....	28
Checking the Model .....	29
Checking the Accessories .....	29
<b>Related Manuals.....</b>	<b>30</b>
<b>Revision History.....</b>	<b>31</b>

## Section 1 Overview

---

<b>1-1 Overview of Functions .....</b>	<b>1-2</b>
1-1-1 Features of 3G3M1 Series Inverter .....	1-2
1-1-2 Classes of 3G3M1 Series Inverter .....	1-4
1-1-3 Compliance with International Standards.....	1-6
<b>1-2 Appearance and Part Names .....</b>	<b>1-7</b>



<b>1-3</b>	<b>Specifications</b> .....	<b>1-11</b>
1-3-1	Standard Specifications .....	1-11
1-3-2	External Dimensions .....	1-18
<b>1-4</b>	<b>Restrictions</b> .....	<b>1-24</b>

## Section 2 Design

<b>2-1</b>	<b>Installation</b> .....	<b>2-2</b>
2-1-1	Inverter Installation .....	2-2
2-1-2	Installation Environment .....	2-2
<b>2-2</b>	<b>Removal of Each Part</b> .....	<b>2-7</b>
2-2-1	Removing Covers .....	2-7
2-2-2	Terminal Blocks .....	2-8
2-2-3	Preparing Backing Plate .....	2-9
<b>2-3</b>	<b>Wiring</b> .....	<b>2-10</b>
2-3-1	Standard Connection Diagram .....	2-10
2-3-2	Arrangement and Function of Main Circuit Terminal Block .....	2-11
2-3-3	Arrangement and Function of Control Circuit Terminal Block .....	2-12
2-3-4	Wiring for Main Circuit Terminals .....	2-15
2-3-5	Wiring for Control Circuit Terminals .....	2-51
2-3-6	Recommended Encoder and Its Wiring .....	2-54
2-3-7	Wiring for RS-485 Communications Terminal Block .....	2-57
2-3-8	Safety Function .....	2-58
<b>2-4</b>	<b>Others</b> .....	<b>2-60</b>
2-4-1	Korean Radio Regulations (KC) .....	2-60
2-4-2	Compliance with EU Directives and UKCA .....	2-60
2-4-3	UL/cUL Standards Cautions .....	2-76

## Section 3 Operation and Test Run

<b>3-1</b>	<b>Operation of Operator</b> .....	<b>3-2</b>
3-1-1	Part Names and Descriptions .....	3-2
3-1-2	Key Operation Method .....	3-3
<b>3-2</b>	<b>Connecting Sysmac Studio</b> .....	<b>3-16</b>
<b>3-3</b>	<b>Flow of Test Run</b> .....	<b>3-17</b>
<b>3-4</b>	<b>Operation Items for Test Run</b> .....	<b>3-18</b>

## Section 4 Parameter List

<b>4-1</b>	<b>List of Monitors by Group</b> .....	<b>4-2</b>
4-1-1	Parameter M (Monitor 1) .....	4-2
4-1-2	Parameter W (Monitor 2) .....	4-30
4-1-3	Parameter z (Alarm Information 1) .....	4-40
4-1-4	Parameter X (Alarm Information 2) .....	4-50
<b>4-2</b>	<b>List of Parameters by Group</b> .....	<b>4-77</b>
4-2-1	Parameter F (Basic Functions) .....	4-77
4-2-2	Parameter E (Terminal Functions) .....	4-84
4-2-3	Parameter C (Frequency Reference and Analog Input Functions) .....	4-99
4-2-4	Parameter P (Motor 1 Parameter) .....	4-112
4-2-5	Parameter H (High Level Functions) .....	4-116
4-2-6	Parameter A (Motor 2 Parameter) .....	4-135
4-2-7	Parameter b (Speed Control 3) .....	4-141
4-2-8	Parameter r (Speed Control 4) .....	4-142
4-2-9	Parameter J (Applied Functions 1) .....	4-143
4-2-10	Parameter d (Applied Functions 2) .....	4-148

4-2-11	Parameter y (RS-485 Communication Settings) .....	4-159
4-2-12	Parameter S (Via RS-485) .....	4-161

## Section 5 Basic Settings

<b>5-1</b>	<b>Display and Initialization .....</b>	<b>5-3</b>
5-1-1	Display Selection .....	5-3
5-1-2	Data Initialization .....	5-4
5-1-3	User Preference Dataset (Registration/Protection) .....	5-8
<b>5-2</b>	<b>Setting V/f Control .....</b>	<b>5-10</b>
5-2-1	Motor Control Method (V/f Characteristics) .....	5-10
5-2-2	Load Mode Selection .....	5-12
5-2-3	Slip Compensation .....	5-16
<b>5-3</b>	<b>Motor Parameter Settings .....</b>	<b>5-19</b>
5-3-1	Induction Motor Basic Settings .....	5-19
5-3-2	Base Frequency and Maximum Frequency of Motor .....	5-19
5-3-3	Motor Electronic Thermal Function .....	5-20
<b>5-4</b>	<b>RUN command .....</b>	<b>5-25</b>
5-4-1	RUN Command Selection .....	5-25
<b>5-5</b>	<b>Frequency Reference .....</b>	<b>5-27</b>
5-5-1	Frequency Reference Selection .....	5-27
5-5-2	Frequency Limit .....	5-32
5-5-3	Pattern Operation / Timed Operation Function .....	5-33
<b>5-6</b>	<b>Acceleration/deceleration time .....</b>	<b>5-39</b>
5-6-1	Acceleration/Deceleration Time Setting .....	5-39
5-6-2	Acceleration/Deceleration Pattern .....	5-40
5-6-3	Acceleration/Deceleration Stop Function .....	5-42
5-6-4	2-step Acceleration/Deceleration Function .....	5-43
<b>5-7</b>	<b>Stop Operation .....</b>	<b>5-47</b>
5-7-1	Stop Selection .....	5-47
<b>5-8</b>	<b>Reset .....</b>	<b>5-49</b>
5-8-1	Reset Function .....	5-49
<b>5-9</b>	<b>Multi-function Input .....</b>	<b>5-51</b>
5-9-1	Input Terminal Functions .....	5-51
<b>5-10</b>	<b>Multi-function output .....</b>	<b>5-67</b>
5-10-1	Output Terminal Functions .....	5-67
<b>5-11</b>	<b>Torque Boost Function .....</b>	<b>5-73</b>
5-11-1	Torque Boost .....	5-73
<b>5-12</b>	<b>Regenerative Braking Function .....</b>	<b>5-75</b>
5-12-1	Regenerative Braking Function .....	5-75
5-12-2	Braking Resistor Electronic Thermal Function .....	5-75

## Section 6 Vector Control and Applied Functions

<b>6-1</b>	<b>Details of Motor Control Methods .....</b>	<b>6-3</b>
6-1-1	Motor Control Methods .....	6-3
6-1-2	Basic Motor Parameter Settings .....	6-4
6-1-3	Motor Parameter Settings .....	6-6
<b>6-2</b>	<b>V/f control with speed feedback .....</b>	<b>6-11</b>
6-2-1	Settings of V/f Control with Speed Feedback .....	6-11
6-2-2	Protective Detection under V/f Control with Speed Feedback .....	6-12
6-2-3	Adjustments for V/f Control with Speed Feedback .....	6-14
<b>6-3</b>	<b>Sensorless Vector Control .....</b>	<b>6-16</b>
6-3-1	Sensorless Vector Control Parameter Settings .....	6-16

6-3-2	Motor Parameter Settings .....	6-17
6-3-3	Adjustments for Sensorless Vector Control .....	6-18
<b>6-4</b>	<b>PM Motor Mode .....</b>	<b>6-20</b>
6-4-1	PM Motor and PM Motor Control .....	6-20
6-4-2	Switching to PM Motor Mode .....	6-21
6-4-3	Offline Auto-tuning for PM Motor Parameters .....	6-22
6-4-4	Adjustment of PM Motor Mode Settings .....	6-22
<b>6-5</b>	<b>Speed Control .....</b>	<b>6-26</b>
6-5-1	Speed Control Settings .....	6-26
<b>6-6</b>	<b>Torque Control .....</b>	<b>6-31</b>
6-6-1	Torque Control Settings .....	6-31
6-6-2	Torque Bias Function Settings .....	6-33
<b>6-7</b>	<b>Position Control .....</b>	<b>6-36</b>
6-7-1	Basic Operation .....	6-36
6-7-2	Position Control Gain .....	6-38
6-7-3	Electronic Gear .....	6-39
6-7-4	Acceleration/Deceleration Time Selection .....	6-40
6-7-5	Positioning Data .....	6-41
6-7-6	Overtravel (OT) .....	6-43
6-7-7	Software OT .....	6-43
6-7-8	Basic Return-to-origin Operation .....	6-44
6-7-9	Clearing of Position .....	6-48
6-7-10	Position Preset .....	6-49
6-7-11	Orientation .....	6-49
6-7-12	Functions That Are Disabled in Position Control .....	6-57
6-7-13	Position Monitor .....	6-57
6-7-14	Restarting Positioning .....	6-58
6-7-15	Brake Control during Position Control .....	6-58
6-7-16	Position Store Selection at Power OFF .....	6-61
6-7-17	Excessive Positional Deviation .....	6-61
6-7-18	Touch Probe (Latch) Function .....	6-62
<b>6-8</b>	<b>Motor tuning .....</b>	<b>6-65</b>
6-8-1	Motor Off-line Auto-tuning .....	6-65
6-8-2	Online Tuning .....	6-71
<b>6-9</b>	<b>Brake Control Function .....</b>	<b>6-72</b>
6-9-1	Operation Sequence of Brake Control Function .....	6-72
6-9-2	Brake Control Function Settings .....	6-76
<b>6-10</b>	<b>Application Control .....</b>	<b>6-78</b>
6-10-1	Application Control Settings .....	6-78
<b>6-11</b>	<b>Torque Limit Function .....</b>	<b>6-81</b>
6-11-1	Torque Limit Function Settings .....	6-81
6-11-2	Torque Monitor .....	6-83
<b>6-12</b>	<b>Overtorque/Undertorque Function .....</b>	<b>6-85</b>
6-12-1	Overtorque/Undertorque Function Settings .....	6-85

## Section 7 Other Functions

<b>7-1</b>	<b>Status Monitors .....</b>	<b>7-3</b>
7-1-1	Operation Monitor .....	7-3
7-1-2	I/O check .....	7-11
7-1-3	Maintenance Information .....	7-13
7-1-4	Alarm information .....	7-18
<b>7-2</b>	<b>Multifunction Input/Output Functions List .....</b>	<b>7-26</b>
7-2-1	Multifunction Input Selection .....	7-26
7-2-2	Multifunction Output Selection .....	7-31
<b>7-3</b>	<b>Analog I/O Settings .....</b>	<b>7-35</b>
7-3-1	Analog Input Function Selection .....	7-35

7-3-2	Analog Input Adjustment Function .....	7-38
7-3-3	Analog Input Filter .....	7-45
7-3-4	Analog Command Hold Function (AHD) .....	7-45
7-3-5	Analog Output Function Selection .....	7-46
7-3-6	Analog Output Adjustment Function .....	7-48
<b>7-4</b>	<b>Restart Functions .....</b>	<b>7-49</b>
7-4-1	Restart Settings .....	7-49
7-4-2	Restart after Momentary Power Failure .....	7-49
7-4-3	Trip Retry Operation .....	7-58
7-4-4	Unattended Start Protection (USP Terminal) .....	7-59
7-4-5	Free Run Restart .....	7-60
<b>7-5</b>	<b>DC Injection Braking Function .....</b>	<b>7-63</b>
7-5-1	DC Injection Braking (DB) .....	7-63
<b>7-6</b>	<b>Safety Function .....</b>	<b>7-69</b>
7-6-1	Overview of Safety Function .....	7-69
7-6-2	Safety Function Settings .....	7-69
7-6-3	Wiring Safety Function for Use .....	7-70
<b>7-7</b>	<b>Digital Operator and Operation Functions .....</b>	<b>7-74</b>
7-7-1	Soft Lock Function (SFT) .....	7-74
7-7-2	Forced Operator Function (OPE) .....	7-75
7-7-3	Forced Terminal Block Function (F-TM) .....	7-75
7-7-4	Initial Screen Selection .....	7-76
7-7-5	Password Function .....	7-77
7-7-6	User Parameter Setting Function .....	7-80
7-7-7	STOP Key Priority/Start Check Function .....	7-80
<b>7-8</b>	<b>Functions Related to Protection, Warning and Various Output Signals .....</b>	<b>7-82</b>
7-8-1	Current Limit/Overload Prevention Control/Overload Warning .....	7-82
7-8-2	Anti-regenerative Control Function .....	7-85
7-8-3	Instantaneous Overcurrent Limitation .....	7-87
7-8-4	External Trip (EXT) .....	7-87
7-8-5	Thermistor Trip Function .....	7-88
7-8-6	Frequency Arrival Signal (FAR1 to 3, FDT1 to 4, FAR1FDT1) .....	7-89
7-8-7	Power ON Time Over/RUN Time (ONT/RNT) .....	7-92
7-8-8	Maintenance monitor .....	7-93
7-8-9	Logic Operation Output Signal (LOG1 to LOG3) .....	7-94
7-8-10	Capacitor Life Warning Signal (WAC) .....	7-96
7-8-11	Braking Transistor Broken (DBAL) .....	7-98
7-8-12	Cooling FAN Control Method Selection .....	7-99
7-8-13	Cooling Fan Life Warning Signal (WAF) .....	7-99
7-8-14	Lifetime Alarm (LIFE) .....	7-100
7-8-15	Communications Disconnection Detection Signal (NDc) .....	7-101
7-8-16	Starting Contact Signal (FR) .....	7-101
7-8-17	Cooling Fin Overheat Warning (OHF) .....	7-102
7-8-18	Low Current Signal (LOC) .....	7-102
7-8-19	Window Comparator/Disconnection Detection (AI1Dc/AIIDc/AIVDc) .....	7-103
7-8-20	Frequency Reference Selection Status Signal (FREF) .....	7-105
7-8-21	RUN Command Status Signal (REF) .....	7-105
7-8-22	2nd control under selection signal (SETM, SWM1) .....	7-105
7-8-23	Inverter Output Limiting (IOL, IOL2) .....	7-106
7-8-24	Low-To-Moderate Voltage Detection (U-EDC) .....	7-106
7-8-25	AX Terminal Function (AX) .....	7-107
7-8-26	Light Alarm Selection .....	7-108
7-8-27	Input Phase Loss Protection / Output Phase Loss Protection .....	7-111
7-8-28	Clearing of Integrated Power (KHC) .....	7-112
<b>7-9</b>	<b>Other Operation Functions .....</b>	<b>7-113</b>
7-9-1	Carrier Frequency .....	7-113
7-9-2	Automatic Carrier Frequency Reduction .....	7-114
7-9-3	Starting Frequency and Stop Frequency .....	7-114
7-9-4	Zero Speed Control .....	7-115
7-9-5	Frequency Jump Function .....	7-116
7-9-6	RUN Direction Limit Selection .....	7-117

7-9-7	Permission of RUN Command .....	7-117
7-9-8	Frequency Calculation Function .....	7-118
7-9-9	Frequency Addition Function .....	7-118
7-9-10	UP/DOWN control .....	7-119
7-9-11	AVR (Automatic Voltage Regulator) Function .....	7-121
7-9-12	Overexcitation Control during Deceleration .....	7-122
7-9-13	PID Function .....	7-123
7-9-14	Automatic Energy-saving Operation Function .....	7-141
7-9-15	Commercial Switching (CS) .....	7-141
7-9-16	Output current fluctuation damping .....	7-144
7-9-17	Pulse Train Frequency Input .....	7-145
7-9-18	LAD Cancel Function .....	7-148
7-9-19	Servo Lock Function .....	7-148
7-9-20	Droop Control .....	7-149
7-9-21	Magnetic Flux Level at Light Load .....	7-150
7-9-22	Pre-excitation .....	7-151
7-9-23	Forced Stop .....	7-152
7-9-24	Overload Stop Function .....	7-153
7-9-25	Battery Operation Enable Command (BATRY) .....	7-155
7-9-26	Universal Terminal .....	7-155
7-9-27	Protection/Maintenance Mode Selection Function .....	7-157

## Section 8 Communications Functions

<b>8-1</b>	<b>Communications Specifications .....</b>	<b>8-3</b>
<b>8-2</b>	<b>RS-485 Terminal Arrangement and Connection .....</b>	<b>8-4</b>
<b>8-3</b>	<b>Modbus Communication Parameters .....</b>	<b>8-5</b>
<b>8-4</b>	<b>Modbus Communication Protocol .....</b>	<b>8-7</b>
8-4-1	Message Configuration .....	8-7
8-4-2	Required Communications Time .....	8-9
8-4-3	Normal Response .....	8-9
8-4-4	Abnormal Response .....	8-9
8-4-5	No Response .....	8-10
<b>8-5</b>	<b>Explanation of Each Function Code .....</b>	<b>8-11</b>
8-5-1	Read Coil Status [01 hex] .....	8-11
8-5-2	Read from Holding Register [03 hex] .....	8-12
8-5-3	Write to Coil [05 hex] .....	8-13
8-5-4	Write to Holding Register [06 hex] .....	8-14
8-5-5	Loop-back Test [08 hex] .....	8-15
8-5-6	Write to Multiple Coils [0F hex] .....	8-16
8-5-7	Write to Multiple Holding Registers [10 hex] .....	8-18
8-5-8	Read/Write from/to Multiple Holding Registers [17 hex] .....	8-19
8-5-9	Exception Response .....	8-20
<b>8-6</b>	<b>Saving a Change to Holding Register (Enter Command) .....</b>	<b>8-21</b>
8-6-1	How to Issue Enter Command .....	8-21
8-6-2	EEPROM Write Mode .....	8-22
<b>8-7</b>	<b>Modbus Mapping Function .....</b>	<b>8-23</b>
8-7-1	Operation of Modbus Mapping Function .....	8-23
8-7-2	Modbus Mapping Function Settings .....	8-23
8-7-3	Writing to Double-word Data .....	8-25
8-7-4	Troubleshooting for Modbus Mapping Function .....	8-25
8-7-5	Endian Function .....	8-25
<b>8-8</b>	<b>Co-inverter Communication .....</b>	<b>8-27</b>
8-8-1	Co-inverter Communication Parameters .....	8-28
8-8-2	Co-inverter Communication Settings .....	8-31
<b>8-9</b>	<b>Modbus Communication Data Lists .....</b>	<b>8-34</b>
8-9-1	Coil Number List .....	8-34
8-9-2	Register List .....	8-36

<b>8-10 Command via Communications .....</b>	<b>8-87</b>
8-10-1 RUN Command via Communications .....	8-87
8-10-2 Frequency Reference via Communications .....	8-87
8-10-3 Forced Commands via Communication .....	8-88

## Section 9 Troubleshooting

<b>9-1 Alarm Display and Remedies.....</b>	<b>9-2</b>
9-1-1 Alarm Display .....	9-2
9-1-2 Alarm Code List.....	9-4
9-1-3 Minor Fault Code List.....	9-25
9-1-4 Other Display List.....	9-26
<b>9-2 Troubleshooting.....</b>	<b>9-28</b>

## Section 10 Maintenance and Inspection

<b>10-1 Maintenance and Inspection.....</b>	<b>10-2</b>
10-1-1 Daily Inspection .....	10-2
10-1-2 Cleaning .....	10-2
10-1-3 Periodic Inspection .....	10-2
10-1-4 Daily/Periodic Inspection Items .....	10-3
10-1-5 Megger Test .....	10-6
10-1-6 Withstand Voltage Test.....	10-7
10-1-7 I/O Voltage/Current/Electric Power Measurement Method .....	10-7

## Appendix

<b>A-1 Derating Table .....</b>	<b>A-2</b>
<b>A-2 Smoothing Capacitor Life Curve .....</b>	<b>A-6</b>
<b>A-3 Life Alarm Output.....</b>	<b>A-9</b>
<b>A-4 Overview of Inverter Selection .....</b>	<b>A-10</b>
A-4-1 Motor Capacity Selection .....	A-10
A-4-2 Inverter Capacity Selection .....	A-13
A-4-3 Overview of Braking Resistor Selection .....	A-14

# Terms and Conditions Agreement

---

## Warranty, Limitations of Liability

### Warranties

---

- **Exclusive Warranty**

Omron's exclusive warranty is that the Products will be free from defects in materials and workmanship for a period of twelve months from the date of sale by Omron (or such other period expressed in writing by Omron). Omron disclaims all other warranties, express or implied.

- **Limitations**

OMRON MAKES NO WARRANTY OR REPRESENTATION, EXPRESS OR IMPLIED, ABOUT NON-INFRINGEMENT, MERCHANTABILITY OR FITNESS FOR A PARTICULAR PURPOSE OF THE PRODUCTS. BUYER ACKNOWLEDGES THAT IT ALONE HAS DETERMINED THAT THE PRODUCTS WILL SUITABLY MEET THE REQUIREMENTS OF THEIR INTENDED USE.

Omron further disclaims all warranties and responsibility of any type for claims or expenses based on infringement by the Products or otherwise of any intellectual property right.

- **Buyer Remedy**

Omron's sole obligation hereunder shall be, at Omron's election, to (i) replace (in the form originally shipped with Buyer responsible for labor charges for removal or replacement thereof) the non-complying Product, (ii) repair the non-complying Product, or (iii) repay or credit Buyer an amount equal to the purchase price of the non-complying Product; provided that in no event shall Omron be responsible for warranty, repair, indemnity or any other claims or expenses regarding the Products unless Omron's analysis confirms that the Products were properly handled, stored, installed and maintained and not subject to contamination, abuse, misuse or inappropriate modification. Return of any Products by Buyer must be approved in writing by Omron before shipment. Omron Companies shall not be liable for the suitability or unsuitability or the results from the use of Products in combination with any electrical or electronic components, circuits, system assemblies or any other materials or substances or environments. Any advice, recommendations or information given orally or in writing, are not to be construed as an amendment or addition to the above warranty.

See <http://www.omron.com/global/> or contact your Omron representative for published information.

### Limitation on Liability; Etc

---

OMRON COMPANIES SHALL NOT BE LIABLE FOR SPECIAL, INDIRECT, INCIDENTAL, OR CONSEQUENTIAL DAMAGES, LOSS OF PROFITS OR PRODUCTION OR COMMERCIAL LOSS IN ANY

WAY CONNECTED WITH THE PRODUCTS, WHETHER SUCH CLAIM IS BASED IN CONTRACT, WARRANTY, NEGLIGENCE OR STRICT LIABILITY.

Further, in no event shall liability of Omron Companies exceed the individual price of the Product on which liability is asserted.

## Application Considerations

### Suitability of Use

Omron Companies shall not be responsible for conformity with any standards, codes or regulations which apply to the combination of the Product in the Buyer's application or use of the Product. At Buyer's request, Omron will provide applicable third party certification documents identifying ratings and limitations of use which apply to the Product. This information by itself is not sufficient for a complete determination of the suitability of the Product in combination with the end product, machine, system, or other application or use. Buyer shall be solely responsible for determining appropriateness of the particular Product with respect to Buyer's application, product or system. Buyer shall take application responsibility in all cases.

NEVER USE THE PRODUCT FOR AN APPLICATION INVOLVING SERIOUS RISK TO LIFE OR PROPERTY OR IN LARGE QUANTITIES WITHOUT ENSURING THAT THE SYSTEM AS A WHOLE HAS BEEN DESIGNED TO ADDRESS THE RISKS, AND THAT THE OMRON PRODUCT(S) IS PROPERLY RATED AND INSTALLED FOR THE INTENDED USE WITHIN THE OVERALL EQUIPMENT OR SYSTEM.

### Programmable Products

Omron Companies shall not be responsible for the user's programming of a programmable Product, or any consequence thereof.

## Disclaimers

### Performance Data

Data presented in Omron Company websites, catalogs and other materials is provided as a guide for the user in determining suitability and does not constitute a warranty. It may represent the result of Omron's test conditions, and the user must correlate it to actual application requirements. Actual performance is subject to the Omron's Warranty and Limitations of Liability.

### Change in Specifications

Product specifications and accessories may be changed at any time based on improvements and other reasons. It is our practice to change part numbers when published ratings or features are changed, or when significant construction changes are made. However, some specifications of the Product may



be changed without any notice. When in doubt, special part numbers may be assigned to fix or establish key specifications for your application. Please consult with your Omron's representative at any time to confirm actual specifications of purchased Product.

## **Errors and Omissions**

---

Information presented by Omron Companies has been checked and is believed to be accurate; however, no responsibility is assumed for clerical, typographical or proofreading errors or omissions.

## **Statement of security responsibilities for assumed use cases and against threats**

OMRON SHALL NOT BE RESPONSIBLE AND/OR LIABLE FOR ANY LOSS, DAMAGE, OR EXPENSES DIRECTLY OR INDIRECTLY RESULTING FROM THE INFECTION OF OMRON PRODUCTS, ANY SOFTWARE INSTALLED THEREON OR ANY COMPUTER EQUIPMENT, COMPUTER PROGRAMS, NETWORKS, DATABASES OR OTHER PROPRIETARY MATERIAL CONNECTED THERETO BY DISTRIBUTED DENIAL OF SERVICE ATTACK, COMPUTER VIRUSES, OTHER TECHNOLOGICALLY HARMFUL MATERIAL AND/OR UNAUTHORIZED ACCESS.

It shall be the users sole responsibility to determine and use adequate measures and checkpoints to satisfy the users particular requirements for (i) antivirus protection, (ii) data input and output, (iii) maintaining a means for reconstruction of lost data, (iv) preventing Omron Products and/or software installed thereon from being infected with computer viruses and (v) protecting Omron Products from unauthorized access.

# Safety Precautions

To ensure that the Multi-function Compact Inverter 3G3M1 Series is used safely and correctly, be sure to read this Safety Precautions section and the main text before using the product.

Learn all items you should know before use, regarding the equipment as well as required safety information and precautions.

Make an arrangement so that this manual also gets to the end user of this product.

After reading this manual, keep it in a convenient place so that it can be referenced at any time.



## Indications and Meanings of Safety Information

In this user's manual, the following precautions and signal words are used to provide information to ensure the safe use of the Multi-function Compact Inverter 3G3M1 Series.





The information provided here is vital to safety. Strictly observe the precautions provided.





The following notation is used.

## Meanings of Signal Words









 <b>WARNING</b>	<p>Indicates an imminently hazardous situation which, if not avoided, is likely to result in serious injury or may result in death. Additionally there may be severe property damage.</p>
 <b>CAUTION</b>	<p>Indicates a potentially hazardous situation which, if not avoided, may result in minor or moderate injury or in property damage.</p>

## Explanation of Symbols

	<p>⊘ This symbol indicates a prohibited item (an item you must not do). The specific instruction is indicated using an illustration or text inside or near ⊘. The symbol shown to the left indicates "non-specific general prohibitions."</p>
	<p>⊘ This symbol indicates a prohibited item (an item you must not do). The specific instruction is indicated using an illustration or text inside or near ⊘. The symbol shown to the left indicates "disassembly prohibited."</p>
	<p>△ This symbol indicates caution and warning. The specific instruction is indicated using an illustration or text inside or near △. The symbol shown to the left indicates "Caution against electric shock."</p>
	<p>△ This symbol indicates caution and warning. The specific instruction is indicated using an illustration or text inside or near △. The symbol shown to the left indicates "Caution against fire."</p>

	<p>△ This symbol indicates caution and warning.</p> <p>The specific instruction is indicated using an illustration or text inside or near △.</p> <p>The symbol shown to the left indicates “general caution.”</p>
	<p>△ This symbol indicates caution and warning.</p> <p>The specific instruction is indicated inside △ as well as by using text.</p> <p>The symbol shown to the left indicates “risk of hot surface.”</p>
	<p>● This symbol indicates a compulsory item (an item that must be done).</p> <p>The specific instruction is indicated using an illustration or text inside or near ●.</p> <p>The symbol shown to the left indicates a “general compulsory item.”</p>
	<p>● This symbol indicates a compulsory item (an item that must be done).</p> <p>The specific instruction is indicated inside ● as well as by using text.</p> <p>The symbol shown to the left indicates “grounding required.”</p>

## **WARNING**

<p>Be sure to ground the ground terminal of the inverter. (200-V class: type-D grounding, 400-V class: type-C grounding)</p> <p>Not doing so may result in a serious injury due to an electric shock or fire.</p>	
<p>Do not remove the surface cover during inverter power supply and for 10 minutes after power shut off.</p> <p>Doing so may result in a serious injury due to an electric shock.</p> <p>Switch various switches, change wiring and perform inspections at least 10 minutes after the power supply has been shut off; after confirming that the Operator is OFF and that a tester or similar tool has been used to confirm that the voltage between the main circuit terminals P(+) and N(-) has dropped to a safe voltage (25 VDC or less).</p>	
<p>There is a risk of severe injury due to electric shock.</p> <p>Wiring work must be carried out only by qualified personnel. Do not touch cables when the power supply is turned ON. Additionally, only designated personnel should perform maintenance or inspections, or replace parts.</p>	
<p>There is a risk of severe injury due to electric shock.</p> <p>After confirming that the power supply is OFF, wait at least 10 minutes and then perform wiring.</p>	
<p>Do not operate the Operator or switches with wet hands. Also, remove metal objects (watches, rings, etc.) before starting work, and use insulating tools when using tools.</p> <p>Not doing so may result in a serious injury due to an electric shock.</p>	
<p>Do not touch the cooling fins, braking resistors and the motor, which become too hot during the power supply and for some time after the power shut off.</p> <p>Doing so may result in a burn.</p>	
<p>Inspection of the inverter must be conducted after the power supply was turned off.</p> <p>Not doing so may result in a serious injury due to an electric shock.</p> <p>The main power supply is not necessarily shut off even if the safety stop function is activated.</p>	
<p>There is a risk of severe injury.</p> <p>Do not enter the operating area during operation.</p>	
<p>There is a risk of severe injury due to electric shock.</p> <p>Do not perform maintenance while the power supply is ON.</p>	

Although this product is manufactured under strict quality control, install equipment to ensure safety when used with applications in which serious accidents or property damage can be anticipated in the event of its failure.

Not doing so may result in accidents.



The Multi-function Compact Inverter (3G3M1 Series) is designed to drive a three-phase induction motor and synchronous motor. Do not use it for single-phase motors or for other purposes.

Doing so may result in fire or accident.



Install the inverter on a non-flammable material such as metallic wall. Also, do not place flammable object nearby.

Doing so may result in fire.



Be sure to perform wiring after installing the inverter unit. Also, tighten terminals with specified torque.

Not doing so may result in injury, electric shock or fire.



Ensure that the specifications of the input power of the product match the power supply to which the product is to be connected.

Not doing so may result in fire or accidents.



Be sure to use the wire of specified size.

Not doing so may result in fire.



When wiring each inverter to the power supply, install a molded-case circuit breaker or earth leakage circuit breaker (with overcurrent protection function). Use recommended molded-case circuit breakers or earth leakage circuit breakers that do not exceed the recommended current capacity.

Not doing so may result in fire.



If no suitable equipment to detect leakage is installed in the upstream power supply line, in order to avoid the entire power supply system's shutdown due to operation of devices such as earth leakage circuit breaker as this is undesirable to operation, install an earth leakage circuit breaker individually to inverters to break the individual inverter power supply lines only.

Not doing so may result in fire.



When the capacity of the power transformer is 500 kVA or more and 10 times or more than the rated capacity of the inverter, ensure that a DC reactor is connected.

Not doing so may result in fire.



Never connect the power lines to the inverter output terminals U, V, or W.

Doing so may result in fire.



When connecting a braking resistor, do not connect it to any terminal other than terminals P(+) and DB.

Doing so may result in fire or accident.



Do not bundle multiple cables as one cable.

Doing so may result in fire.



Do not connect a surge suppressor to the output lines of the inverter.













Doing so may result in fire.



In general, sheaths of the control signal wires do not use reinforced insulation, therefore if a control signal wire comes into direct contact with a live part of the main circuit, the insulation of the sheath might break down. In these cases, there is a danger of the control signal wire being exposed to high voltage from the main circuit, therefore ensure that the control signal wires will not come into contact with live parts of the main circuit.

Not doing so may result in electric shock or accidents.



<p>Even if the inverter has interrupted power to the motor, if the voltage is applied to the main circuit input terminals L1/R, L2/S and L3/T, voltage may be output to inverter output terminals U, V and W. This may result in a serious injury due to an electric shock.</p>	
<p>Even if the motor is stopped due to DC braking or pre-excitation, voltage is output to inverter output terminals U, V and W. This may result in a serious injury due to an electric shock.</p>	
<p>Starting auto-tuning involves motor rotation. Sufficiently check that motor rotation carries with it no danger beforehand. Not doing so may result in injury or accidents.</p>	
<p>The inverter may operate with acceleration/deceleration time or speed different from as set due to stall prevention function. Design the machine so that safety is ensured even in such cases. Not doing so may result in accidents.</p>	
<p>The inverter can easily have high-speed operation set. When changing the speed setting, carefully check the specifications of motors or machine beforehand. Additionally, set the parameters only after fully understanding the User's Manual. If the user recklessly changes the parameters and then operates the inverter, the motor may rotate at a torque or speed not permitted for the machine. This may result in injury.</p>	
<p>If you enable the "Restart mode after momentary power failure" (F014 = 3 or 4), then the inverter automatically restarts running the motor when the power is recovered. Design the machine so that safety is ensured even after such restarts. Not doing so may result in injury or accidents.</p>	
<p>The STOP key on the Operator may be disabled due to parameter setting, etc. Provide an emergency stop switch separately. Not doing so may result in accidents.</p>	
<p>If the motor stops as a result of a trip, the inverter may automatically restart and drive the motor depending on the parameter setting. Design the machine so that human safety and the safety of surroundings is ensured at the time of restarting. Not doing so may result in accidents.</p>	
<p>Remove any cause of the protective functions operating, then check the RUN command is OFF and cancel the alarm. Canceling the alarm when the RUN command is ON means that the inverter will supply power to the motor, which may start rotation thus posing a danger. This may result in accidents.</p>	
<p>When switching start methods or speed by external input, the motor may start suddenly or the speed may abruptly change. This may result in injury or accidents.</p>	
<p>Input terminals have functions such as run, stop and speed change. If the parameters are changed while signals are input to the input terminals, the motor operation may suddenly change. Ensure that you change parameters only after fully securing safety. Not doing so may result in injury or accidents.</p>	
<p>The branch circuit protection being open may indicate an interruption in the fault current. In order to reduce the danger of fire and electric shock, inspect energized parts and other controller components, and replace if damaged. In the event of the overload relay current element burning out, the entire overload relay must be replaced. Not doing so may result in a serious injury due to an electric shock or fire.</p>	
<p>Output terminals (ROA, ROB) use relays, and may remain ON, OFF or undetermined when their lifetime is reached. For safety, equip the inverter with an external protective function. Not doing so may result in fire or accidents.</p>	

Do not dismantle, repair or modify the product.  
Doing so may result in injury or electric shock.



Always carry out the daily and periodic inspections described in the User's Manual. Use of the inverter for long periods of time without carrying out regular inspections could result in malfunction or damage of the inverter, and an accident or fire could occur.  
This may result in fire or accident.



It is recommended that parts for periodic replacement be replaced in accordance with the standard replacement frequency indicated in the User's manual. Use of the inverter for long periods of time without replacement could result in malfunction or damage of the inverter, and an accident or fire could occur.  
This may result in fire or accident.



It is recommended that periodic inspections be carried out every one to two years, however, they should be carried out more frequently depending on the usage conditions.  
Not doing so may result in fire or accident.



When using a DC reactor, AC reactor, braking resistor or noise filter, etc., there is the possibility that a human body may touch the main circuit terminal block (live parts). In such cases, take measures such as installing the inverters in a location not easily accessible by humans.  
Not doing so may result in a serious injury due to an electric shock.



There are conditions for compliance with the EU Low Voltage Directive and Machinery Directive. Strictly observe the conditions listed in the instruction manual or user's manual.  
Not doing so may result in a serious injury due to an electric shock or fire.



## Security Measures

### Anti-virus protection

Install the latest commercial-quality antivirus software on the computer connected to the control system and maintain to keep the software up-to-date.



### Security measures to prevent unauthorized access

Take the following measures to prevent unauthorized access to our products.

- Install physical controls so that only authorized personnel can access control systems and equipment.
- Reduce connections to control systems and equipment via networks to prevent access from untrusted devices.
- Install firewalls to shut down unused communications ports and limit communications hosts and isolate control systems and equipment from the IT network.
- Use a virtual private network (VPN) for remote access to control systems and equipment.
- Adopt multifactor authentication to devices with remote access to control systems and equipment.
- Set strong passwords and change them frequently.
- Scan virus to ensure safety of USB drives or other external storages before connecting them to control systems and equipment.



### Data input and output protection

Validate backups and ranges to cope with unintentional modification of input/output data to control systems and equipment.

- Checking the scope of data
- Checking validity of backups and preparing data for restore in case of falsification and abnormalities
- Safety design, such as emergency shutdown and fail-soft operation in case of data tampering and abnormalities



**Data recovery**

Backup data and keep the data up-to-date periodically to prepare for data loss.



When using an intranet environment through a global address, connecting to an unauthorized terminal such as a SCADA, HMI or to an unauthorized server may result in network security issues such as spoofing and tampering.

You must take sufficient measures such as restricting access to the terminal, using a terminal equipped with a secure function, and locking the installation area by yourself.



When constructing an intranet, communication failure may occur due to cable disconnection or the influence of unauthorized network equipment.

Take adequate measures, such as restricting physical access to network devices, by means such as locking the installation area.



When using a device equipped with the SD Memory Card function, there is a security risk that a third party may acquire, alter, or replace the files and data in the removable media by removing the removable media or unmounting the removable media.

Please take sufficient measures, such as restricting physical access to the Controller or taking appropriate management measures for removable media, by means of locking the installation area, entrance management, etc., by yourself.



**Caution**

If connecting a commercially available braking resistor or regenerative braking unit, this may result in a moderate burn due to the heat generated in the braking resistor or regenerative braking unit.

In case of a braking resistor, install a thermal relay that monitors the temperature of the resistor. Configure a sequence that enables the inverter power to turn OFF when unusual over heating is detected in the braking resistor or regenerative braking unit.



The inverter has high voltage parts inside which, if short-circuited, might cause damage to itself or other property.

Place covers on the openings or take other precautions to make sure that no metal objects such as cutting bits or lead wire scraps go inside when installing and wiring.



Install a stop motion device to ensure safety. Not doing so might result in a minor injury. (A holding brake is not a stop motion device designed to ensure safety.)



Be sure to confirm safety before conducting maintenance, inspection or parts replacement.



A breakdown of the built-in braking transistor could result in braking resistor heating or damage to the inverter's internal units. Shut off the main power of the inverter using Braking transistor broken signal (DBAL).



A breakdown of the built-in braking transistor or misconnection of the braking resistor could result in braking resistor heating or damage to the inverter's internal units.

If the inverter does not start up or continue being undervoltage (LU) after the main power of the inverter is turned ON, shut off the main power of the inverter.



When installing the product, use only the specified screws.

Not doing so may result in fire or accidents.



Do not install or operate an inverter with damaged external or internal components.

Doing so may result in injury, fire or accidents.



Prevent lint, paper fibers, sawdust, dust, metallic chips, or other foreign materials from getting into the inverter or from accumulating on the cooling fin.  
Not doing so may result in fire or accidents.



Support the inverter case or cooling fin instead of the surface cover during transportation.  
Not doing so may result in injury due to the inverter dropping.



The inverter, motor and wiring generate electric noise. Be careful about malfunction of the nearby sensors and devices. Take noise control measures to prevent them from malfunctioning.  
Not doing so may result in accidents.



The inverter has an overload protection function. Set the protection level using parameters.



The brake function of the inverter does not provide any holding mechanism. Provide a separate holding brake if necessary.  
Not doing so may result in injury.



Comply with the local ordinance and regulations when disposing of the product.  
Not doing so may result in injury.



UL and cUL compliance is subject to conditions. Strictly observe the conditions listed in the instruction manual or user's manual.  
Not doing so may result in fire or accidents.





# Precautions for Safe Use

## Installation and Storage

Do not store or use the product in the following places.

- Locations subject to direct sunlight.
- Locations subject to ambient temperature exceeding the specifications.
- Locations subject to relative humidity exceeding the specifications.
- Locations subject to condensation due to severe temperature fluctuations.
- Locations subject to corrosive or flammable gases.
- Locations subject to exposure to combustibles.
- Locations subject to dust (especially iron dust) or salts.
- Locations subject to exposure to water, oil, or chemicals.
- Locations subject to shock or vibration.

## Transportation, Installation, and Wiring

- Do not drop or apply strong impact on the product. Doing so may result in damaged parts or malfunction.
- Do not connect an AC power supply voltage to the control input/output terminals. Doing so may result in damage to the product. Also, check the voltage and current of the connected circuit and implement wiring correctly.
- Take sufficient shielding measures when using the product in the following locations. Not doing so may result in damage to the product.
  - Locations subject to static electricity or other forms of noise
  - Locations subject to strong magnetic fields
  - Locations close to power lines
- If there is noise or other effects, install a ferrite core. When installing a ferrite core, do not allow the shield sheath to be caught between the communications connector and the cable. Not doing so may cause insufficient noise reduction effect, resulting in the Inverter to malfunction.
- Fix the shield wire or use other means so that it is not subject to a heavy load. Shield wire breakage may occur due to the weight of the ferrite core.
- When carrying out wiring of communications line and configuring network settings, refer to applicable sections of the manual to ensure correct connection and configuration procedures.
- Install an appropriate stopping device to ensure safety. In particular, if configured to operate continuously even in the event of a communications error, the Inverter may not stop, resulting in equipment damage.

## Operation and Adjustment

- When checking a signal during the power supply and the voltage is erroneously applied to the control input terminals, the motor may start abruptly. Be sure to confirm safety before checking a signal.
- When changing parameters, do not turn OFF the inverter unit until saving is completed.
- Even when the inverter power is turned OFF, the counter-electromotive force occurs while the PM motor rotates, which may result in electric shock.

Do not remove the surface cover of the inverter until the PM motor stops.

## Maintenance and Inspection

- The capacitor service life is influenced by the ambient temperature. Refer to “Smoothing Capacitor Life Curve” described in the manual. When a capacitor reaches the end of its service life and does not work as the product, you need to replace the capacitor.

# Precautions for Correct Use

## Maintenance and Parts Replacement

- When a cooling fan reaches the end of its service life, replace it.

## Product Disposal

Comply with the local ordinance and regulations when disposing of the product.



■ This mark urges disposal in accordance with the WEEE Directive.

## Warning Label

- This product bears a warning label at the following location to provide handling warnings.
- Be sure to follow the instructions.

The appearance differs depending on the capacity of the inverter.

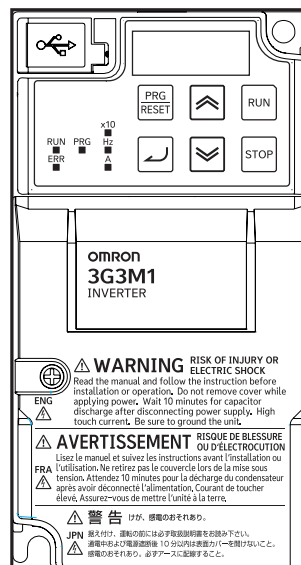

## Warning Description

	<p> <b>WARNING</b> RISK OF INJURY OR ELECTRIC SHOCK</p> <p>Read the manual and follow the instruction before installation or operation. Do not remove cover while applying power. Wait 10 minutes for capacitor discharge after disconnecting power supply. High touch current. Be sure to ground the unit.</p>
ENG	<p> <b>AVERTISSEMENT</b> RISQUE DE BLESSURE OU D'ÉLECTROCUTION</p> <p>Lisez le manuel et suivez les instructions avant l'installation ou l'utilisation. Ne retirez pas le couvercle lors de la mise sous tension. Attendez 10 minutes pour la décharge du condensateur après avoir déconnecté l'alimentation. Courant de toucher élevé. Assurez-vous de mettre l'unité à la terre.</p>
FRA	<p> <b>警告</b> けが、感電のおそれあり。</p> <p><b>JPN</b> 据え付け、運転の前には必ず取扱説明書をお読み下さい。 通電中および電源遮断後 10 分以内は表面カバーを開けないこと。  感電のおそれあり。必ずアースに配線すること。</p>

# Regulations and Standards

To export (or provide to nonresident aliens) any part of this product that falls under the category of goods (or technologies) for which an export certificate or license is mandatory according to the Foreign Exchange and Foreign Trade Control Law of Japan, an export certificate or license (or service transaction approval) according to this law is required.

Standard		Applicable standard
CE	EMC	EN 61800-3:2004/A1:2012
UKCA	Functional safety	EN 61800-5-2 :2017 STO SIL3 EN/ISO 13849-1:2015, Cat.3 / PLe
	Electrical safety	EN 61800-5-1:2017
UL	US	UL61800 -5-1, Edition 1, 2012
	CA	CSA-C22.2 No.274, 2017
KC	KS-C9800-3	
EAC	-	
RCM	EN 61800-3:2004+A1:2012	

The customer must check the conditions that must be met for compliance with the environmental standards and regulations of their respective country.

## 1. Checking use of regulated chemical substances

This product complies with regulated substances used in electrical parts based on the RoHS Directive.

For details on the Certificate of Conformance and other regulations, contact the place of purchase.

## 2. Motor efficiency regulations

This product is subject to energy efficiency regulations when it is used in motor systems that are driven by an inverter. For details on inverter efficiency with respect to motor output in accordance with EU efficiency regulations, refer to the following website.

<https://industrial.omron.eu/en/company-info/environmental/ecodesign-directive>

# Items to Check after Unpacking



After unpacking, check the following items.

- Is this the model you ordered?
- Was there any damage sustained during shipment?









## Checking the Nameplate

The nameplate is affixed to the product.

### 7.5 kW or lower

Inverter model	→	<b>OMRON 3G3M1-A4004 INVERTER</b>	←	Unit version										
Input specifications	→	<table border="1"> <tr> <th>ND</th> <th>HD</th> <th>HND</th> <th>HHD</th> <th>LOT No. 23456 Ver. 1.0</th> </tr> <tr> <td>2.7A</td> <td>2.7A</td> <td>2.7A</td> <td>1.7A</td> <td>50/60Hz, 380Y/220-480Y/277V, 3Ph</td> </tr> </table>	ND	HD	HND	HHD	LOT No. 23456 Ver. 1.0	2.7A	2.7A	2.7A	1.7A	50/60Hz, 380Y/220-480Y/277V, 3Ph		
ND	HD	HND	HHD	LOT No. 23456 Ver. 1.0										
2.7A	2.7A	2.7A	1.7A	50/60Hz, 380Y/220-480Y/277V, 3Ph										
Output specifications	→	<table border="1"> <tr> <th>ND</th> <th>HD</th> <th>HND</th> <th>HHD</th> <th>LOT No. 23456 Ver. 1.0</th> </tr> <tr> <td>2.1A</td> <td>1.8A</td> <td>2.1A</td> <td>1.8A</td> <td>0.1-590Hz, 380-480V, 3Ph</td> </tr> </table>	ND	HD	HND	HHD	LOT No. 23456 Ver. 1.0	2.1A	1.8A	2.1A	1.8A	0.1-590Hz, 380-480V, 3Ph		
ND	HD	HND	HHD	LOT No. 23456 Ver. 1.0										
2.1A	1.8A	2.1A	1.8A	0.1-590Hz, 380-480V, 3Ph										
		<table border="1"> <tr> <th>120% 1min</th> <th>120% 1min</th> <th>150% 1min</th> <th>150% 1min</th> </tr> <tr> <td>MOTOR: 0.75kW</td> <td>0.75kW</td> <td>0.75kW</td> <td>0.4kW</td> </tr> </table>	120% 1min	120% 1min	150% 1min	150% 1min	MOTOR: 0.75kW	0.75kW	0.75kW	0.4kW				
120% 1min	120% 1min	150% 1min	150% 1min											
MOTOR: 0.75kW	0.75kW	0.75kW	0.4kW											
		IE2/LOSS: 0.0% 0.0% 0.0% 0.0%												
		SCCR: 100kA IP20 Date. 2022/XX												
		S/N: W14A123A0579AA 101												
		 R-R-OMR-3G3M1-00001												
														
		OMRON Corporation Shiokoji Horikawa, Shimogyo-ku, Kyoto, MADE IN JAPAN 600-8530 JAPAN												

### 11 kW or higher

Inverter model	→	<b>OMRON 3G3M1-A4110 INVERTER</b>	←	Unit version										
Input specifications	→	<table border="1"> <tr> <th>ND</th> <th>HD</th> <th>HND</th> <th>HHD</th> <th>LOT No. 23456 Ver. 1.0</th> </tr> <tr> <td>52.3A</td> <td>43.8A</td> <td>43.8A</td> <td>33A</td> <td>50/60Hz, 380Y/220-480Y/277V, 3Ph</td> </tr> </table>	ND	HD	HND	HHD	LOT No. 23456 Ver. 1.0	52.3A	43.8A	43.8A	33A	50/60Hz, 380Y/220-480Y/277V, 3Ph		
ND	HD	HND	HHD	LOT No. 23456 Ver. 1.0										
52.3A	43.8A	43.8A	33A	50/60Hz, 380Y/220-480Y/277V, 3Ph										
Output specifications	→	<table border="1"> <tr> <th>ND</th> <th>HD</th> <th>HND</th> <th>HHD</th> <th>LOT No. 23456 Ver. 1.0</th> </tr> <tr> <td>37A</td> <td>31A</td> <td>31A</td> <td>24A</td> <td>0.1-590Hz, 380-480V, 3Ph</td> </tr> </table>	ND	HD	HND	HHD	LOT No. 23456 Ver. 1.0	37A	31A	31A	24A	0.1-590Hz, 380-480V, 3Ph		
ND	HD	HND	HHD	LOT No. 23456 Ver. 1.0										
37A	31A	31A	24A	0.1-590Hz, 380-480V, 3Ph										
		<table border="1"> <tr> <th>120% 1min</th> <th>120% 1min</th> <th>150% 1min</th> <th>150% 1min</th> </tr> <tr> <td>MOTOR: 18.5kW</td> <td>15kW</td> <td>15kW</td> <td>11kW</td> </tr> </table>	120% 1min	120% 1min	150% 1min	150% 1min	MOTOR: 18.5kW	15kW	15kW	11kW				
120% 1min	120% 1min	150% 1min	150% 1min											
MOTOR: 18.5kW	15kW	15kW	11kW											
		IE2/LOSS: 0.0% 0.0% 0.0% 0.0%												
		SCCR: 100kA IP20 Date. 2022/XX												
		S/N: W14A123A0579AA 101												
		 R-R-OMR-3G3M1-00001												
														
		OMRON Corporation Shiokoji Horikawa, Shimogyo-ku, Kyoto, MADE IN JAPAN 600-8530 JAPAN												
		      IND.CONT.EQ. 7B98												

## Checking the Model

3 G 3 M 1 - A 2 0 5 5

Maximum applicable motor capacity (HHD rating)

001	0.1kW
002	0.2kW
004	0.4kW
007	0.75kW
015	1.5kW
022	2.2kW
030	3.0kW
037	3.7kW
040	4.0kW
055	5.5kW
075	7.5kW
110	11kW
150	15kW
185	18.5kW
220	22kW

Voltage class

B	Single phase 200 VAC (200-V class)
2	Three-phase 200 VAC (200-V class)
4	Three-phase 400 VAC (400-V class)

Enclosure rating

A	Panel-mounting (IP10 or higher) or closed wall-mounting models
---	--

## Checking the Accessories

The instruction manual is the only accessory included in the Multi-function Compact Inverter (3G3M1 Series).

Mounting screws and other necessary parts must be provided by the user.

# Related Manuals

---

The following table summarizes the manuals relating to this manual. Read these manuals together with this manual.

Name	Catalog No.	Model	Application	Description
Sysmac Studio Version 1 Operation Manual	W504	SYSMAC-SE2□□□	To learn about how to operate Sysmac Studio and its features.	Describes how to operate Sysmac Studio.
Sysmac Studio Version 1 Drive Functions Operation Manual	I589	SYSMAC-SE2□□□	To learn about how to set and adjust the inverter.	Describes how to operate Sysmac Studio.



# Revision History

---

The manual revision code is an alphabet appended to the end of the catalog number found in the bottom right-hand corner of the front cover and in the bottom left-hand corner of the back cover.

Example

<b>Man.No.</b>	<b>I669-E1-01</b>
----------------	-------------------

↑  
Revision code

Revision code	Revision date	Revised content
01	September 2022	Original production
02	January 2023	• Improved descriptions, etc
03	March 2023	• Improved descriptions, etc



# 1

## Overview

This section provides an overview of the 3G3M1 Series features, standard specifications, and external dimensions by inverter capacity. It also shows the differences of this inverter from conventional inverters for those who use previous models.

---

<b>1-1</b>	<b>Overview of Functions</b> .....	<b>1-2</b>
1-1-1	Features of 3G3M1 Series Inverter .....	1-2
1-1-2	Classes of 3G3M1 Series Inverter .....	1-4
1-1-3	Compliance with International Standards .....	1-6
<b>1-2</b>	<b>Appearance and Part Names</b> .....	<b>1-7</b>
<b>1-3</b>	<b>Specifications</b> .....	<b>1-11</b>
1-3-1	Standard Specifications .....	1-11
1-3-2	External Dimensions .....	1-18
<b>1-4</b>	<b>Restrictions</b> .....	<b>1-24</b>

# 1-1 Overview of Functions

The Multi-function Compact Inverter (3G3M1 Series) provides a variety of functions such as PM motor control and simple position control. It is also designed for open field networks to extend application usability.

In addition, the 3G3M1 Series complies as standard with both the EC Directives and UL/cUL Standards. You can use this product as a world standard inverter.

## 1-1-1 Features of 3G3M1 Series Inverter

The 3G3M1 Series Inverter has the following features.

### Enhanced Application Support

Although this inverter is compact, it provides high functionality for enhanced application support and addresses diverse needs with optimal performance.

#### ● PM motors

In addition to conventional induction motors, this inverter provides the PM motor mode that supports highly efficient PM motors, which results in highly efficient control.

This is combined with the OMRON's unique auto-tuning function and magnetic pole position estimation function that estimates the magnetic pole position of a PM motor during startup to enable its smooth start.

This control is suitable for applications with reduced torque characteristics (which do not require torque at low speeds) such as fans and pumps.

#### ● Implementation of the dual rating function

This inverter has the dual rating function that consists of the heavy load mode and the light load mode.

This enables the efficient utilization of the inverter depending on your application.

- Heavy load mode (HHD/HD)

The heavy load mode is used for a transfer machine, elevator, or other device that temporarily requires a torque exceeding the rated torque. This mode enables high torque control similar to that achieved with the previous product.

The current overload capacity is 1 minute at 150% of the rated current and 0.5 seconds at 200% of the rated current.

- Light load mode (HND/ND)

The light load mode is used for a fan, pump, or other device that operates at the rated motor torque or lower.

Setting the light load mode causes the rated current of the inverter to increase, enabling the inverter to drive a motor whose capacity is one size larger.

However, check when selecting an inverter because this also decreases the current overload capacity to 120% of the rated current for one minute.

### ● Position control

This inverter provides position control that enables the control of up to eight points with a single inverter unit.

With the standard pulse train input function, it realizes accurate position control based on the feedback of the pulse generator (PG) signal or the encoder's phase-A/B signal.

### ● PID control function

The inverter provides PID control that adjusts the feedback value to match the target value. This is available to the process control such as temperature, pressure, flow rate.

### ● Modbus communication functions

This inverter has built-in Modbus communication functions as standard.

These Modbus communication functions of the inverter include sophisticated, convenient functions as listed below.

- Modbus mapping : Up to 10 register addresses can be set as desired. This is convenient, for example, when designing a replacement.
- Broadcasting to up to five groups (Simultaneous broadcast) : Broadcasting to up five inverter groups can be performed by dividing those located within a single network connected to this inverter. It is useful to reduce the variation in the startup timings within a group.
- High transmission speed : This inverter supports the maximum transmission speed of 115.2 kbps. This helps reduce the communications data processing time.
- Co-inverter communication : Mutual data exchange can be performed among inverters, without presence of the master in Modbus communication.

## Environmental Consideration

OMRON gives consideration to not only the functions inherent to the inverter, but also its service life and energy efficiency.

This inverter, as a standard, complies with the RoHS Directive and other international standards to realize an environmental-friendly inverter.

### ● Automatic energy-saving function

The automatic energy-saving function automatically adjusts the output power of the inverter operating at a constant speed to the minimum. It has an energy-saving effect in applications such as a fan or pump.

### ● Side-by-side installation

This inverter can be installed side by side, which contributes to the reduction of the installation space.

Depending on the model, the reduction of the carrier frequency and the derating of the rated current are required. Refer to *2-1-2 Installation Environment* on page 2-2 for details.

## Ease of Use

This inverter is also designed for ease of use in terms of the parameter settings, protection, and operations.

This contributes to the reduction of man-hours in inverter-related work.

### ● Password Function

This inverter has the password protection function to prevent unauthorized reading and changing of parameters.

### ● Initial screen automatic return function of the Operator

You can register the initial screen (data etc.) to display on its Operator.

After operating the Digital Operator for adjustment or inverter monitoring, the screen will return to the initial screen unless you operate any key for five minutes.

### ● Simplified parameter setting by user parameters

Any parameters can be registered as user parameters.

It is possible to display only the registered parameters to improve the operability of equipment.

## 1-1-2 Classes of 3G3M1 Series Inverter

There are three voltage classes for 3G3M1 Series Inverters: 200-V class supporting single-phase 200 VAC and three-phase 200 VAC, and 400-V class supporting three-phase 400 VAC.

The maximum applicable motor capacity for this inverter is 0.1 to 22 kW for the heavy load mode and 0.2 to 30 kW for the light load mode.

All models comply as standard with the EC Directives and UL/cUL Standards.

Rated voltage	Enclosure rating	Maximum applicable motor capacity		Model
		HHD: Heavy load	HND: Light load	
Three-phase 200 VAC	IP20	0.1 kW	0.2 kW	3G3M1-A2001
		0.2 kW	0.4 kW	3G3M1-A2002
		0.4 kW	0.75 kW	3G3M1-A2004
		0.75 kW	1.1 kW	3G3M1-A2007
		1.5 kW	2.2 kW	3G3M1-A2015
		2.2 kW	3.0 kW	3G3M1-A2022
		3.7 kW	5.5 kW	3G3M1-A2037
		5.5 kW	7.5 kW	3G3M1-A2055
		7.5 kW	11 kW	3G3M1-A2075
		11 kW	15 kW	3G3M1-A2110
		15 kW	18.5 kW	3G3M1-A2150
		18.5 kW	22 kW	3G3M1-A2185

Rated voltage	Enclosure rating	Maximum applicable motor capacity		Model
		HHD: Heavy load	HND: Light load	
Three-phase 400 VAC	IP20	0.4 kW	0.75 kW	3G3M1-A4004
		0.75 kW	1.1 kW	3G3M1-A4007
		1.5 kW	2.2 kW	3G3M1-A4015
		2.2 kW	3.0 kW	3G3M1-A4022
		3.0 kW	4.0 kW	3G3M1-A4030
		4.0 kW	5.5 kW	3G3M1-A4040
		5.5 kW	7.5 kW	3G3M1-A4055
		7.5 kW	11 kW	3G3M1-A4075
		11 kW	15 kW	3G3M1-A4110
		15 kW	18.5 kW	3G3M1-A4150
		18.5 kW	22 kW	3G3M1-A4185
		22 kW	30 kW	3G3M1-A4220
Single-phase 200 VAC	IP20	0.1 kW	0.2 kW	3G3M1-AB001
		0.2 kW	0.4 kW	3G3M1-AB002
		0.4 kW	0.55 kW	3G3M1-AB004
		0.75 kW	1.1 kW	3G3M1-AB007
		1.5 kW	2.0 kW	3G3M1-AB015
		2.2 kW	2.7 kW	3G3M1-AB022
		3.7 kW	-	3G3M1-AB037

## Checking the Model

3 G 3 M 1 - A 2 0 0 1

Maximum applicable motor capacity (HHD rating)

001	0.1kW
002	0.2kW
004	0.4kW
007	0.75kW
015	1.5kW
022	2.2kW
030	3.0kW
037	3.7kW
040	4.0kW
055	5.5kW
075	7.5kW
110	11kW
150	15kW
185	18.5kW
220	22kW

Voltage class

B	Single-phase 200 VAC (200-V class)
2	Three-phase 200 VAC (200-V class)
4	Three-phase 400 VAC (400-V class)

Enclosure rating

A	Panel-mounting or closed wall-mounting models
---	---

### 1-1-3 Compliance with International Standards

The 3G3M1 Series is compliant with the IEC international standard and so supports safety standards within Europe and other countries.

Standard		Applicable standard
CE	EMC	EN 61800-3:2004/A1:2012
UKCA	Functional safety	EN 61800-5-2 :2017 STO SIL3 EN/ISO 13849-1:2015, Cat.3 / PLe
	Electrical safety	EN 61800-5-1:2017
UL	US	UL61800 -5-1, Edition 1, 2012
	CA	CSA-C22.2 No.274, 2017
KC	KS-C9800-3	
EAC	-	
RCM	EN 61800-3:2004+A1:2012	



# 1-2 Appearance and Part Names

The following shows the front view when the product is unpacked.

(An example of 3G3M1-AB001/AB002/AB004/AB007/A2001/A2002/A2004/A2007)

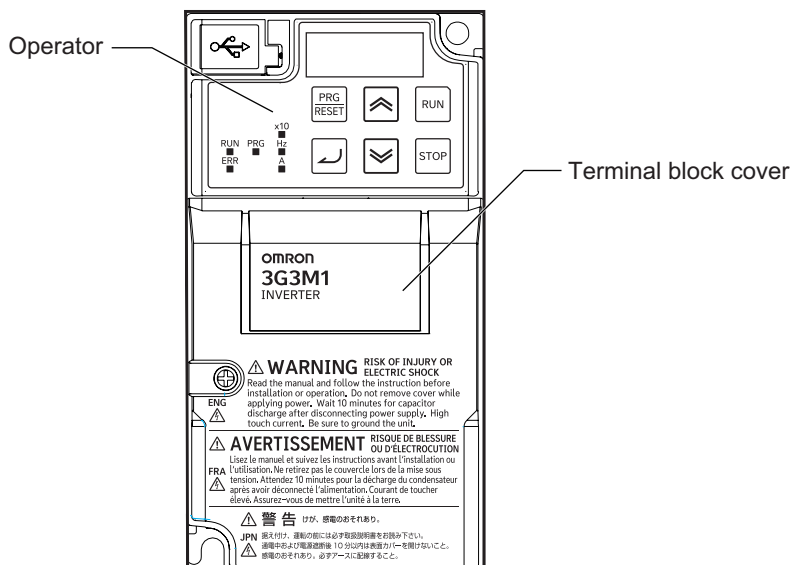

Open the terminal block cover to wire the main circuit terminal block and the control circuit terminal block.

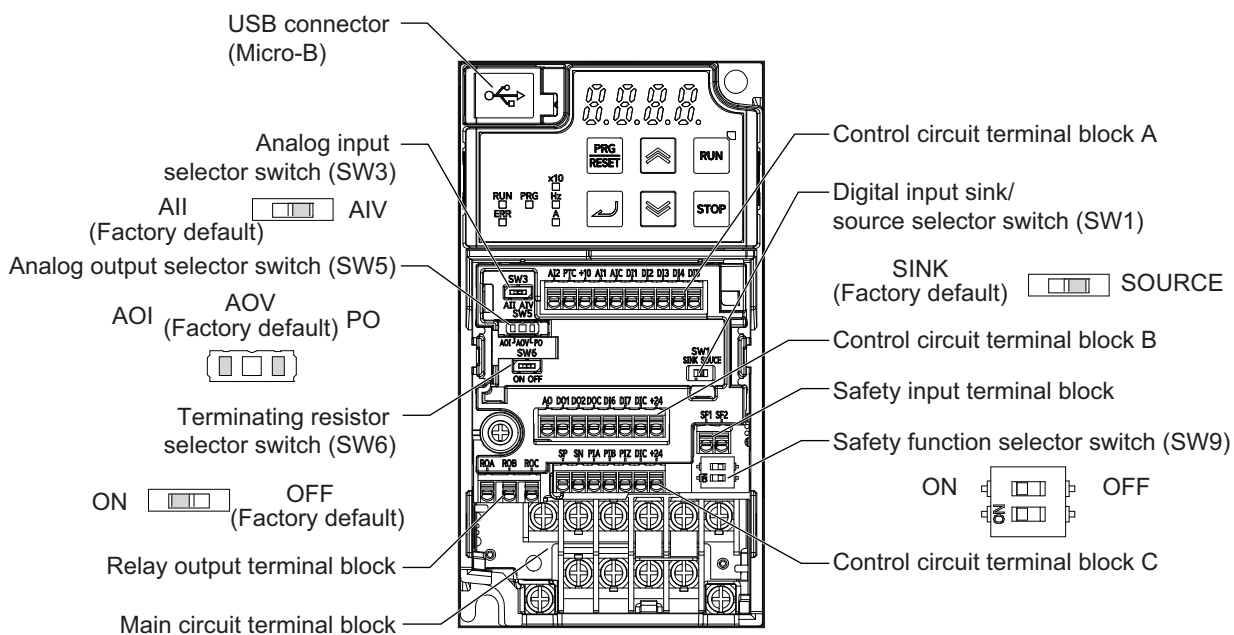

The figures below show the components of each Inverter model.

Single-phase 200 V, 0.1/0.2/0.4/0.75 kW

Three-phase 200 V, 0.1/0.2/0.4/0.75 kW

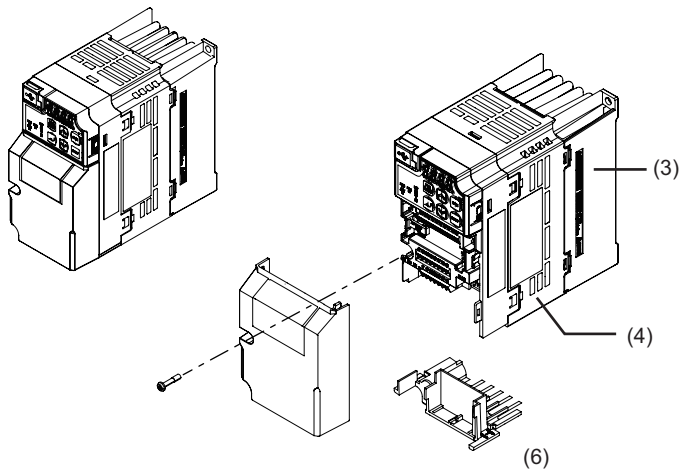

Single-phase 200 V, 1.5 kW

Three-phase 200 V, 1.5/2.2 kW

Three-phase 400 V, 0.4/0.75/1.5/2.2 kW

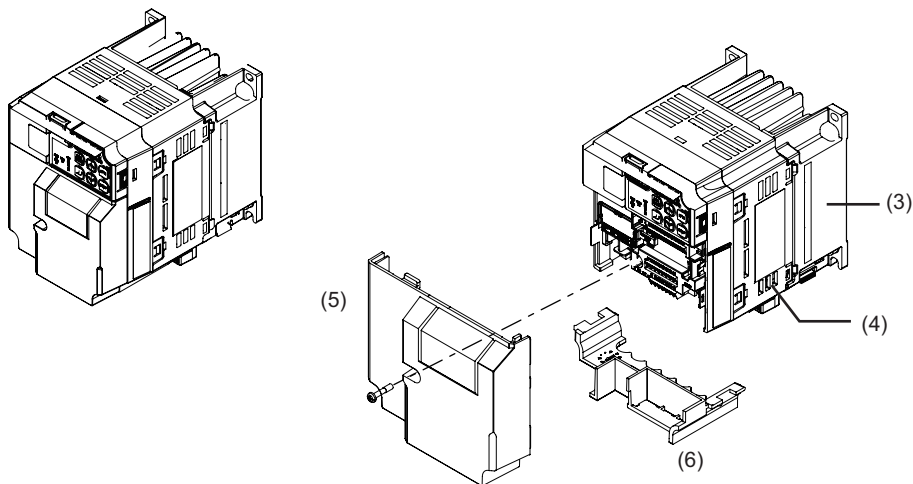

(1) Cooling Fan Cover

(2) Cooling Fan

(3) Cooling Fin

(4) Inverter Case

(5) Surface cover (Terminal block cover)

(6) Surface cover (Backing plate)

**Note** The single-phase 200-V, 1.5-kW and three-phase 200-V, 1.5-kW models have a cooling fan. The three-phase 400-V, 0.4/0.75/1.5 kW model, however, has no cooling fan.

Single-phase 200 V, 2.2 kW  
 Three-phase 200 V, 3.7 kW  
 Three-phase 400 V, 3.0/4.0 kW

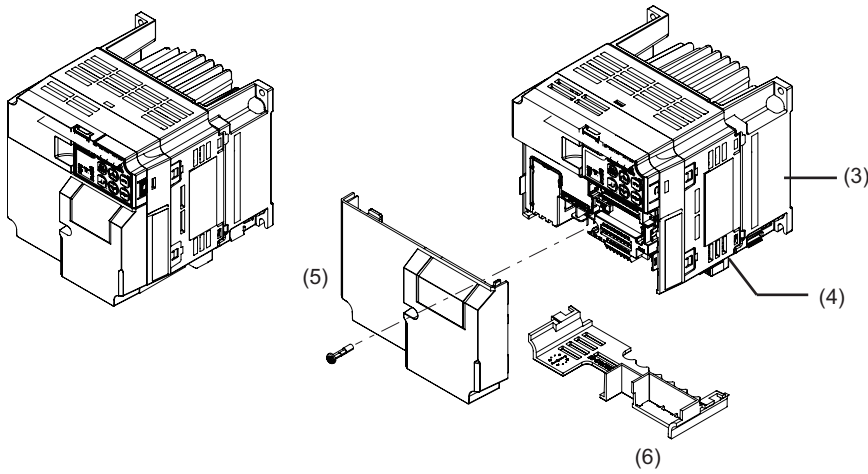

Single-phase 200 V, 3.7 kW  
 Three-phase 200 V, 5.5/7.5 kW  
 Three-phase 400 V, 5.5/7.5 kW

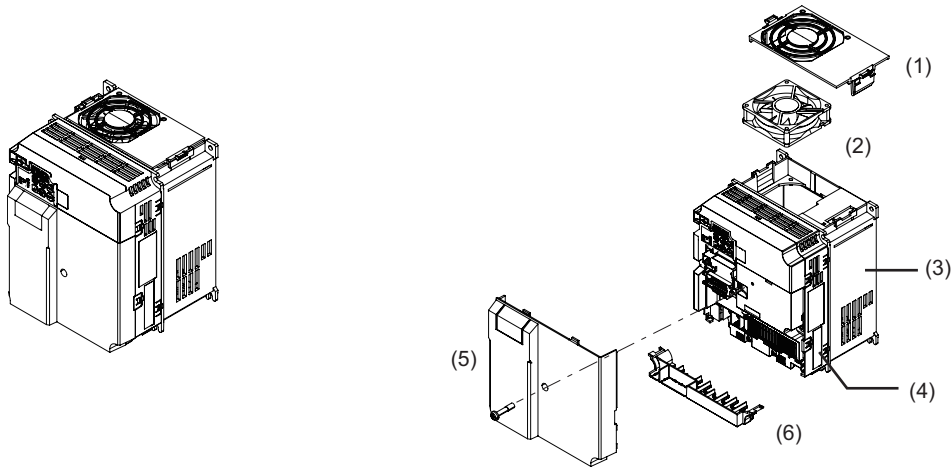

- (1) Cooling Fan Cover
- (2) Cooling Fan
- (3) Cooling Fin

- (4) Inverter Case
- (5) Surface cover (Terminal block cover)
- (6) Surface cover (Backing plate)

Three-phase 200 V, 11/15 kW  
 Three-phase 400 V, 11/15 kW

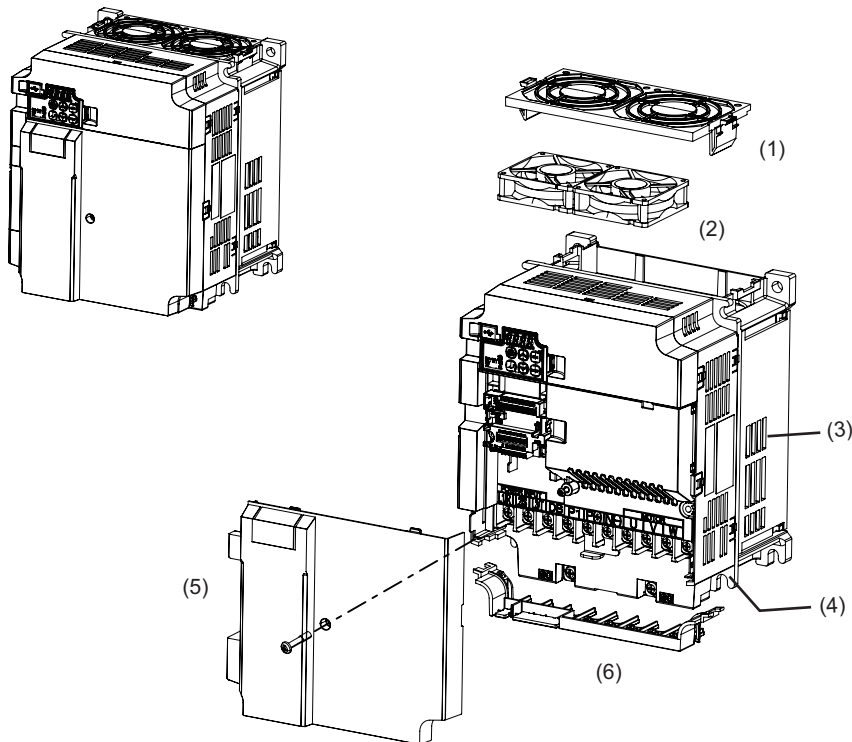

Three-phase 200 V, 18.5/22 kW  
 Three-phase 400 V, 18.5/22 kW

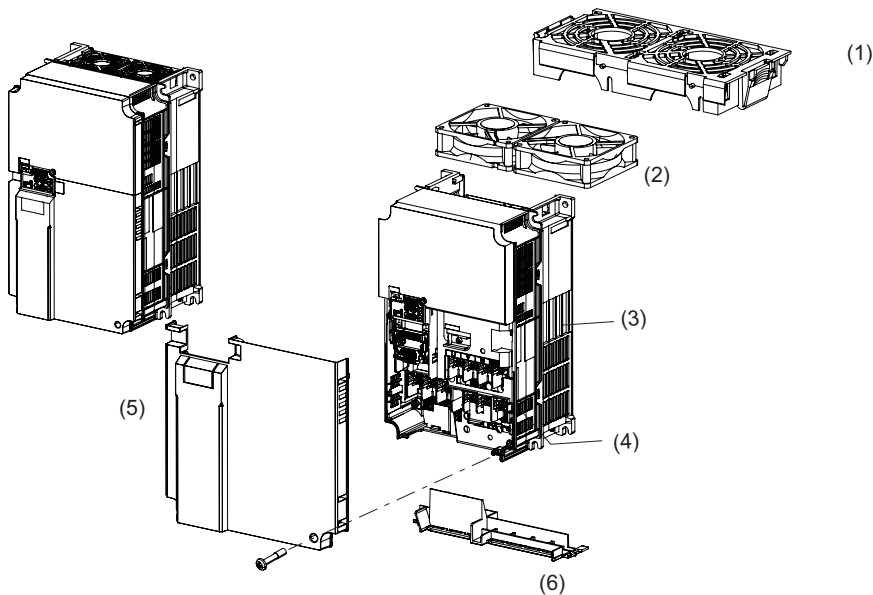

(1) Cooling Fan Cover

(2) Cooling Fan

(3) Cooling Fin

(4) Inverter Case

(5) Surface cover (Terminal block cover)

(6) Surface cover (Backing plate)

# 1-3 Specifications

## 1-3-1 Standard Specifications

### Three-phase 200-V Class

HHD: Heavy load, HND: Light load

Item		Three-phase 200 V												
Model (3G3M1-A2□□□)		001	002	004	007	015	022	037	055	075	110	150	185	
Maximum applicable motor capacity*1	kW	HHD	0.1	0.2	0.4	0.75	1.5	2.2	3.7	5.5	7.5	11	15	18.5
		HND	0.2	0.4	0.75	1.1	2.2	3*7	5.5*7	7.5	11	15	18.5	22
	HP	HHD	1/8	1/4	1/2	1	2	3	5	7 1/2	10	15	20	25
		HND	1/4	1/2	1	1 1/2	3	4	7 1/2	10	15	20	25	30
Rated output capacity [kVA]*2	200 V	HHD	0.3	0.6	1	1.7	2.8	3.8	6.1	8.7	11	16	21	26
		HND	0.5	0.7	1.2	2.1	3.3	4.2	6.8	10	14	19	24	30
	240 V	HHD	0.4	0.7	1.2	2.1	3.3	4.6	7.3	10	14	20	25	32
		HND	0.5	0.8	1.5	2.5	4.0	5.0	8.1	12	17	23	29	37
Rated input voltage*3		Three-phase 200 to 240 V, 50/60 Hz												
Rated input current [A]*4	HHD	1.1	1.8	3.1	5.3	9.5	13.2	22.2	31.5	42.7	60.7	80	97	
	HND	1.8	2.6	4.9	6.7	12.8	17.9	28.5	42.7	60.7	80	97	112	
Rated output voltage		Three-phase 200 to 240 V (with AVR)												
Rated output current [A]*5	HHD	1	1.6	3	5	8	11	17.5	25	33	47	60	76	
	HND	1.3	2	3.5	6	9.6	12*7	19.6 *7	30	40	56	69	88	
Braking torque [%]*6	HHD	150		100		70	40		20					
	HND	75		53	68	48	29*7	27*7	15					
Braking resistor circuit	Regenerative braking	Built-in braking resistor circuit (discharge resistor separately mounted)												
	Minimum connection resistance [Ω]	100 to 120				40 to 120			33 to 120	20 min.	15 min.	10 min.	8.6 min.	4 min.
Short circuit current rating [kA]		100												
Weight [kg]		0.5	0.5	0.6	0.8	1.4	1.4	1.7	3.8	4	5.3	5.4	11	
Dimensions (Width × Height) [mm]		68×127				110×130			140 × 130	180×220		220×260		250 × 400
Dimensions (Depth) [mm]		98		113	145	156			171		203		203	

\*1. The maximum applicable motor capacity is given for a standard four-phase motor. When selecting an inverter, select not just by kW but also ensure that the inverter rated output current is greater than the motor rated current.

\*2. In calculating the rated capacity, the rated output voltage is assumed to be 200 V or 240 V.

- \*3. A voltage higher than the power supply voltage cannot be output.
- \*4. When Carrier Frequency (F26) is set to the following or below, derating is required.  
 HHD mode...A2001 to A2037: 8 kHz, A2055 to A2185: 10 kHz  
 HND mode...A2001 to A2037: 4 kHz, A2055 to A2150: 10 kHz, A2185: 4 kHz  
 For derating, refer to *A-1 Derating Table* on page A-2.
- \*5. The following shows the calculated value when the power supply capacity is 500 kVA (10x the inverter capacity when the inverter capacity exceeds 50 kVA) and when a %X = 5% power supply is connected.
- \*6. The numeric value is the average braking torque per individual motor. (Varies according to motor efficiency)
- \*7. Allowable ambient temperature of 40°C or below of A2022 to A2037 in the HND mode.  
 The rated output current in the HND mode decreases by 1% for every temperature increase of 1°C when the ambient temperature is 40°C or more.

## Three-phase 400-V Class

HHD/HD: Heavy load, HND/ND: Light load

Item			Three-phase 400 V											
Model (3G3M1-A4□□□)			004	007	015	022	030	040	055	075	110	150	185	220
Maximum applicable motor capacity*1	kW	HD	0.75	1.1	2.2	3	4	5.5	7.5	11	15	18.5	22	30
		ND	0.75	1.5	2.2	3	4	5.5	11	15	18.5	22	30	37
		HHD	0.4	0.75	1.5	2.2	3	4	5.5	7.5	11	15	18.5	22
		HND	0.75	1.1	2.2	3*7	4	5.5*7	7.5	11	15	18.5	22	30
	HP	HD	1	1 1/2	3	4	5	7 1/2	10	15	20	25	30	40
		ND	1	1 1/2	3	4	5	7 1/2	15	20	25	30	40	50
		HHD	1/2	1	1 1/2	3	4	5	7 1/2	10	15	20	25	30
		HND	1	1 1/2	3	4	5	7 1/2	10	15	20	25	30	40
Rated output capacity [kVA]*2	380 V	HD	1.2	2.2	3.3	4.1	5.8	7.3	12	15	20	25	30	39
		ND	1.4	2.7	3.6	4.5	6.1	7.9	14	19	24	29	39	47
		HHD	1.2	2.2	3.2	3.6	4.7	6.1	9.7	12	16	20	26	30
		HND	1.4	2.7	3.6	4.5	5.8	7.3	12	15	20	25	30	39
	480 V	HD	1.5	2.8	4.2	5.2	7.3	9.2	15	19	26	32	37	50
		ND	1.7	3.4	4.6	5.7	7.6	10	18	24	31	37	49	60
		HHD	1.5	2.8	4	4.6	6	7.6	12.3	15	20	26	32	37
		HND	1.7	3.4	4.6	5.7	7.3	9.2	15	19	26	32	37	50
Rated input voltage*3			Three-phase 380 to 480 V, 50/60 Hz											
Rated input current [A]*4	HD	2.7	3.9	7.3	11.3	14.2	16.8	23.2	33	43.8	52.3	60.6	77.9	
	ND	2.7	4.8	7.3	11.3	14.2	16.8	33	43.8	52.3	60.6	77.9	94.3	
	HHD	1.7	3.1	5.9	8.2	11.3	14.2	17.3	23.2	33	43.8	52.3	60.6	
	HND	2.7	3.9	7.3	11.3	14.2	16.8	23.2	33	43.8	52.3	60.6	77.9	
Rated output voltage			Three-phase 380 to 480 V (with AVR)											

Item		Three-phase 400 V											
Rated output current [A] <sup>*5</sup>	HD	1.8	3.4	5	6.3	8.8	11.1	17.5	23	31	38	45	60
	ND	2.1	4.1	5.5	6.9	9.2	12	21.5	28.5	37	44	59	72
	HHD	1.8	3.4	4.8	5.5	7.2	9.2	14.8	18	24	31	39	45
	HND	2.1	4.1	5.5	6.9 <sup>*7</sup>	8.8	11.1 <sup>*7</sup>	17.5	23	31	38	45	60
Braking torque [%] <sup>*6</sup>	HD	53.3	68.2	47.7	29.3	29.3	26.9	15					
	ND	53.3	50.0	47.7	29.3	29.3	26.9	12					
	HHD	100		70	40	40	40	20					
	HND	53	68	48	29 <sup>*7</sup>	29	27 <sup>*7</sup>	15					
Braking resistor circuit	Regenerative braking	Built-in braking resistor circuit (discharge resistor separately mounted)											
	Minimum connection resistance [Ω]	200		160 to 200		130 to 200		80 min.	60 min.	40 min.	34.4 min.	16 min.	
Short circuit current rating [kA]		100											
Weight [kg]		1.1	1.4	1.4	1.4	1.7	1.7	3.8	3.8	5.2	5.4	11	11
Dimensions (Width × Height) [mm]		110×130			140×130			180×220		220×260		250×400	
Dimensions (Depth) [mm]		132	156				171		203		203		

- \*1. The maximum applicable motor capacity is given for a standard four-phase motor. When selecting an inverter, select not just by kW but also ensure that the inverter rated output current is greater than the motor rated current.
- \*2. In calculating the rated capacity, the rated output voltage is assumed to be 380 V or 480 V.
- \*3. A voltage higher than the power supply voltage cannot be output.
- \*4. When Carrier Frequency (F26) is set to the following or below, derating is required.  
 HHD mode...A4004 to A4040: 8 kHz, A4055 to A4220: 10 kHz  
 HND mode...A4004 to A4040: 8 kHz, A4055 to A4185: 10 kHz, A4220: 6 kHz  
 HD and ND...modes All models: 4 kHz  
 For derating, refer to *A-1 Derating Table* on page A-2.
- \*5. The following shows the calculated value when the power supply capacity is 500 kVA (10x the inverter capacity when the inverter capacity exceeds 50 kVA) and when a %X = 5% power supply is connected.
- \*6. The numeric value is the average braking torque per individual motor. (Varies according to motor efficiency)
- \*7. Allowable ambient temperature of 40°C or below of A4022 to A4040 in the HND mode.  
 The rated output current of A4022 and A4040 in the HND mode decreases by 1% for every temperature increase of 1°C when the ambient temperature is 40°C or more.

## Single-phase 200-V Class

HHD: Heavy load, HND: Light load

Item	Single-phase 200 V						
Model (3G3M1-AB□□□)	001	002	004	007	015	022	037

Item			Single-phase 200 V						
Maximum applicable motor capacity*1	kW	HHD	0.1	0.2	0.4	0.75	1.5	2.2	3.7
		HND	0.2	0.4	0.55	1.1	2*8	2.7*9	-
	HP	HHD	1/8	1/4	1/2	1	2	3	5
		HND	1/4	1/2	3/4	1 1/2	3	4	-
Rated output capacity [kVA]*2	200 V	HHD	0.3	0.6	1	1.7	2.8	3.8	6.1
		HND	0.4	0.7	1.2	2.1	3.3	4.2	-
	240 V	HHD	0.4	0.7	1.2	2.1	3.3	4.6	7.3
		HND	0.5	0.8	1.5	2.5	4	5	-
Rated input voltage*3			Single-phase 200 to 240 V, 50/60 Hz						
Rated input current [A]*4	HHD	1.8	3.3	5.4	9.7	16.4	22	45.4	
	HND	3.3	4.9	7.3	13.8	20.2	26	-	
Rated output voltage			Single-phase 200 to 240 V (with AVR)						
Rated output current [A]*5	HHD	1	1.6	3	5	8	11	17.5	
	HND	1.2	1.9	3.5*7	6.0*7	9.6*7	12*7	-	
Braking torque [%]*6	HHD	150		100		70	40	40	
	HND	75		73	68	48	29	-	
Braking resistor circuit	Regenerative braking		Built-in braking resistor circuit (discharge resistor separately mounted)						
	Minimum connection resistance [Ω]		100 to 120			40 to 120			
Short circuit current rating [kA]			100						
Weight [kg]			0.5	0.5	0.6	0.9	1.4	1.7	3.8
Dimensions (Width × Height) [mm]			68×127			110×130	140×130	180×220	
Dimensions (Depth) [mm]			98	120	165	166	156	171	

- \*1. The maximum applicable motor capacity is given for a standard four-phase motor. When selecting an inverter, select not just by kW but also ensure that the inverter rated output current is greater than the motor rated current.
- \*2. In calculating the rated capacity, the rated output voltage is assumed to be 200 V or 240 V.
- \*3. A voltage higher than the power supply voltage cannot be output.
- \*4. When Carrier Frequency (F26) is set to the following or below, derating is required.  
 HHD mode...AB001 to A2037: 8 kHz  
 HND mode...AB001 to A2022: 4 kHz  
 For derating, refer to *A-1 Derating Table* on page A-2.
- \*5. The following shows the calculated value when the power supply capacity is 500 kVA (10x the inverter capacity when the inverter capacity exceeds 50 kVA) and when a %X = 5% power supply is connected.
- \*6. The numeric value is the average braking torque per individual motor. (Varies according to motor efficiency)
- \*7. Allowable ambient temperature of 40°C or below of AB004, AB007, AB015 and AB022.  
 The rated output current in the HND mode decreases by 2% for every temperature increase of 1°C when the ambient temperature is 40°C or more.
- \*8. The maximum applicable motor capacity is 2.2 kW when the input voltage is 220 to 240 V.
- \*9. The maximum applicable motor capacity is 3.0 kW when the input voltage is 220 to 240 V.



## Common Specifications

Item		Specifications
Enclosure rating* <sup>1</sup>		Open type (IP20)
Control	Control method	Phase-to-phase sinusoidal modulation PWM
	Output frequency range* <sup>2</sup>	5.00 to 590 Hz
	Frequency precision	Digital command: $\pm 0.01\%$ of the maximum frequency, Analog command: $\pm 0.2\%$ of the maximum frequency ( $25 \pm 10^\circ\text{C}$ )
	Frequency setting resolution	Digital setting: 0.01 Hz, Analog setting: Maximum frequency $\times 5/10,000$
	Overload current rating of inverter	Heavy load rating (HHD): 150%/60 s or 200%/0.5 s Heavy load rating (HD): 150%/60 s Light load rating (HND/ND): 120%/60 s
	Instantaneous overcurrent protection	<ul style="list-style-type: none"> <li>Digital setting: 0.01 Hz (99.99 Hz max.), 0.1 Hz (100.0 to 590.0 Hz)</li> <li>Analog setting: Maximum frequency <math>\times 5/10,000</math></li> <li>Communication setting: 0.005% of the maximum output frequency or 0.01 Hz (fixed)</li> </ul>
	Acceleration/Deceleration time	0.00 to 6000 s (line/curve arbitrary setting), 2nd acceleration/deceleration setting provided
Carrier frequency change range	<p>Three-phase 400-V class</p> <ul style="list-style-type: none"> <li>3G3M1-A4004 to A4185 0.75 to 16 kHz (HHD/HND/HD) 0.75 to 10 kHz (ND)</li> <li>3G3M1-A4220 0.75 to 16 kHz (HHD) 0.75 to 10 kHz (HND/HD) 0.75 to 6 kHz (ND)</li> </ul> <p>Three-phase 200-V class</p> <ul style="list-style-type: none"> <li>3G3M1-A2001 to A2015, A2055 to A2185 0.75 to 16 kHz (HHD/HND)</li> <li>3G3M1-A2022/A2037 0.75 to 16 kHz (HHD) 0.75 to 10 kHz (HND)</li> </ul> <p>Single-phase 200-V class</p> <ul style="list-style-type: none"> <li>3G3M1-AB001 to AB022 0.75 to 16 kHz (HHD) 0.75 to 10 kHz (HND)</li> <li>3G3M1-AB037 0.75 to 16 kHz (HHD)</li> </ul> <p>The carrier frequency automatically drops according to the ambient temperature and output current. (This function can be disabled.)</p>	

Item		Specifications
Control	Starting torque	<ul style="list-style-type: none"> <li>• 150% min. / Rated speed of 10% V/f control (IM motor) V/f control (slip compensation) V/f control with speed sensor (IM motor)</li> <li>• 200% min./0.5 Hz Vector control without speed sensor (dynamic vector control) (IM motor) V/f control with speed feedback (Automatic torque boost) Sensorless vector control</li> <li>• 200% min./0.0 Hz (0 Hz torque control) Vector control with speed sensor (IM motor) Vector control with speed and pole position sensor (PM motor) To obtain 200% starting torque at low speed, consider raising the capacity of the inverter to the next higher capacity.</li> <li>• 200% min. / Rated speed of 10% Vector control without speed and pole position sensor (PM motor) To obtain these starting torques at low speed, the capacity of the inverter and motor must be taken into consideration.</li> </ul> <p>The maximum torque that can be used is limited when the current capacity matched to the mode is exceeded. Current capacity of 200% in HDD mode, 150% in HD mode, and 120% in HND and ND modes</p>
	Protective function	Overcurrent, Overvoltage, Undervoltage, Electronic thermal, Temperature error, Ground-fault current at power-on, Inrush current protection circuit, Overload limit, Incoming overvoltage, External trip, Memory error, CPU error, USP error, Communication error, Overvoltage suppression during deceleration, Power interruption protection, Emergency shutoff, etc.
Input signal	Frequency settings	Operator External analog input signal (variable resistor/0 to 10 VDC/-10 to 10 VDC/4 to 20 mA), Modbus communication
	RUN/STOP command	Operator External digital input signal (3-wire input available), Modbus communication
	Multi-function Input <sup>*3</sup>	Seven points (DI1 to DI7, Functions can be selected from among 101)
	Analog input <sup>*4</sup>	Two points (voltage AI1 terminal: 10 bits/-10 to 10 VDC, voltage AI2 (AIV) terminal: 10 bits/0 to 10 V, current AI2 (AII) terminal: 10 bits/4 to 20 mA or 0 to 20 mA)
	Pulse input	One point (A, B, Z phases can be input, max. 32 kHz, 5 to 24 VDC)
Output signal	Multi-function output <sup>*3</sup>	Two points (DO1 and DO2, Functions can be selected from among 92)
	Relay output <sup>*3</sup>	One point (SPDT contact (ROA, ROB, ROC), Functions can be selected from among 92)
	Analog output <sup>*5</sup>	One point (AO (AOV) terminal: Voltage 10 bits/0 to 10 V, AO (AOI) terminal: Current 10 bits/4 to 20 mA or 0 to 20 mA, AO (PO) terminal: Max. 32 kHz, 0 to 11 V)
	Pulse output	
Communications	RS-485	RJ45 connector (for Digital Operator)
	RS-485	Control circuit terminal block, Modbus communication
	USB	USB 2.0, Micro-B connector

Item		Specifications											
Other functions		AVR function, V/f characteristics switching, Upper/Lower limit, Multi-step speed (16 steps), Starting frequency adjustment, Jogging operation, Carrier frequency adjustment, PID control, Frequency jump, Analog gain/bias adjustment, S-shape acceleration/deceleration, Electronic thermal characteristics/ level adjustment, Restart function, Torque boost function, Fault monitor, Soft lock function, Frequency conversion display, USP function, 2nd control function, UP/DOWN, Overcurrent suppression function, etc.											
General specifications	Operating ambient temperature*6	-10 to 50°C (Derating required)											
	Storage ambient temperature	-25 to 70°C (Short-time temperature during shipment)											
	Operating ambient humidity	5% to 95% (with no condensation)											
	Vibration resistance	<table border="1"> <thead> <tr> <th>Vibration Frequency</th> <th>Specification</th> </tr> </thead> <tbody> <tr> <td>2 to less than 9Hz</td> <td>3mm (0.12inch) (Max. amplitude)</td> </tr> <tr> <td>9 to less than 20Hz</td> <td>1G</td> </tr> <tr> <td>20 to less than 55Hz</td> <td>0.2G</td> </tr> <tr> <td>55 to less than 200Hz</td> <td>0.1G</td> </tr> </tbody> </table>		Vibration Frequency	Specification	2 to less than 9Hz	3mm (0.12inch) (Max. amplitude)	9 to less than 20Hz	1G	20 to less than 55Hz	0.2G	55 to less than 200Hz	0.1G
		Vibration Frequency	Specification										
2 to less than 9Hz		3mm (0.12inch) (Max. amplitude)											
9 to less than 20Hz		1G											
20 to less than 55Hz	0.2G												
55 to less than 200Hz	0.1G												
Location	At a maximum altitude of 1,000 m, indoors (without corrosive gases or dust)												

- \*1. The enclosure rating complies with JISC0920.
- \*2. If you must use the motor at higher than 50/60 Hz, check the allowable maximum motor speed and other information with the motor manufacturer.
- \*3. In the HND/ND (light load) mode or PM motor mode compared with the HHD/HD (heavy load) mode, for some parameters, the default data and setting range also differ. For details, refer to *5-2-2 Load Mode Selection* on page 5-12.
- \*4. By default, the maximum frequency is adjusted to 10 V for a voltage input of 0 to 10 VDC and to 20 mA for a current input of 4 to 20 mA, respectively. If necessary, adjust the default parameter settings. For details, refer to *7-3-2 Analog Input Adjustment Function* on page 7-38.
- \*5. The analog output shows values that can only be used as a guide for analog meter connection. The maximum output value may differ from 10 V or 20 mA due to the variability of the analog output circuit. If necessary, adjust the default parameter settings.
- \*6. Derating of the rated output current of the inverter may be required depending on the heavy/light load mode selection, operating ambient temperature, side-by-side installation, and carrier frequency settings. Use the inverter in an appropriate environment according to *A-1 Derating Table* on page A-2.

### 1-3-2 External Dimensions

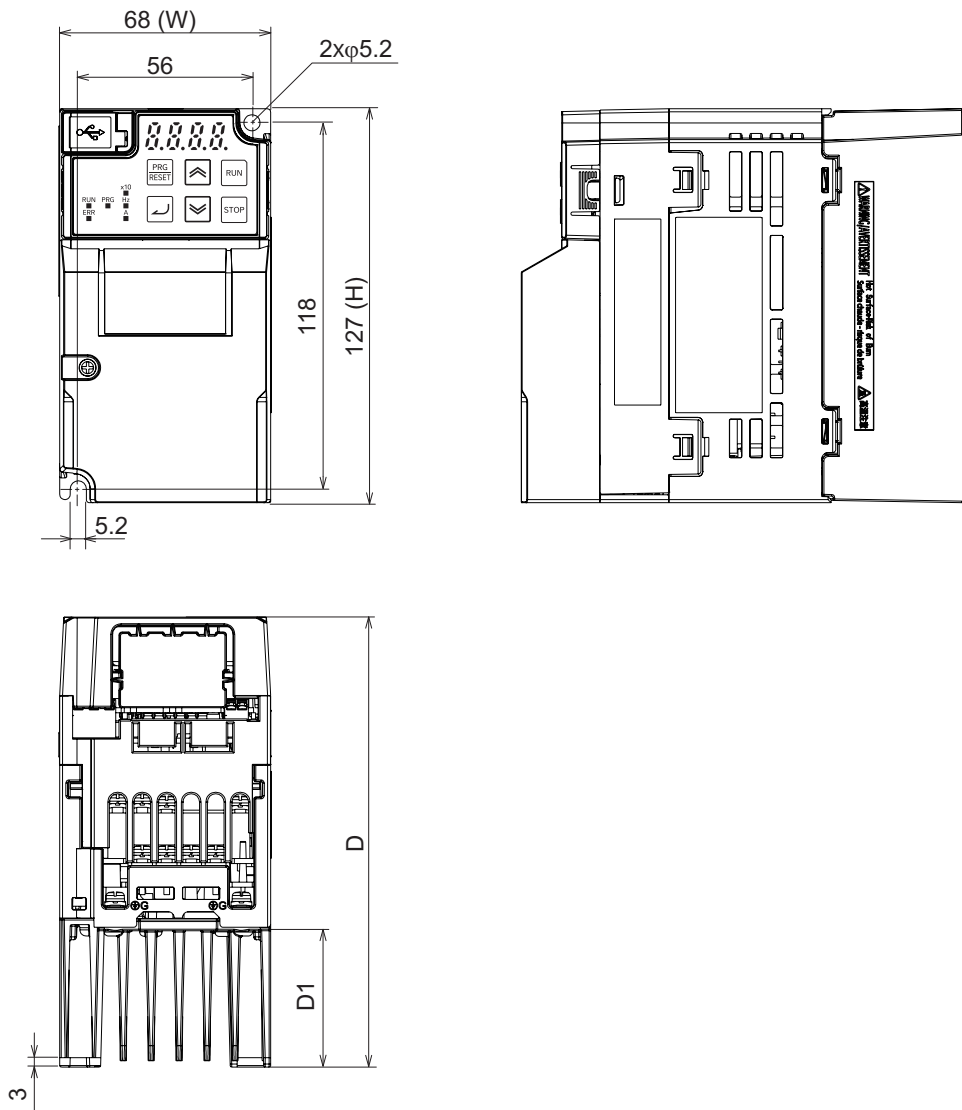

Power supply	Model	W [mm]	H [mm]	D [mm]	D1 [mm]
Single-phase 200 V	3G3M1-AB001 3G3M1-AB002	68	127	98	8
	3G3M1-AB004 3G3M1-AB007			120	23
				165	48
Three-phase 200 V	3G3M1-A2001 3G3M1-A2002	68	127	98	8
	3G3M1-A2004 3G3M1-A2007			113	23
				145	48

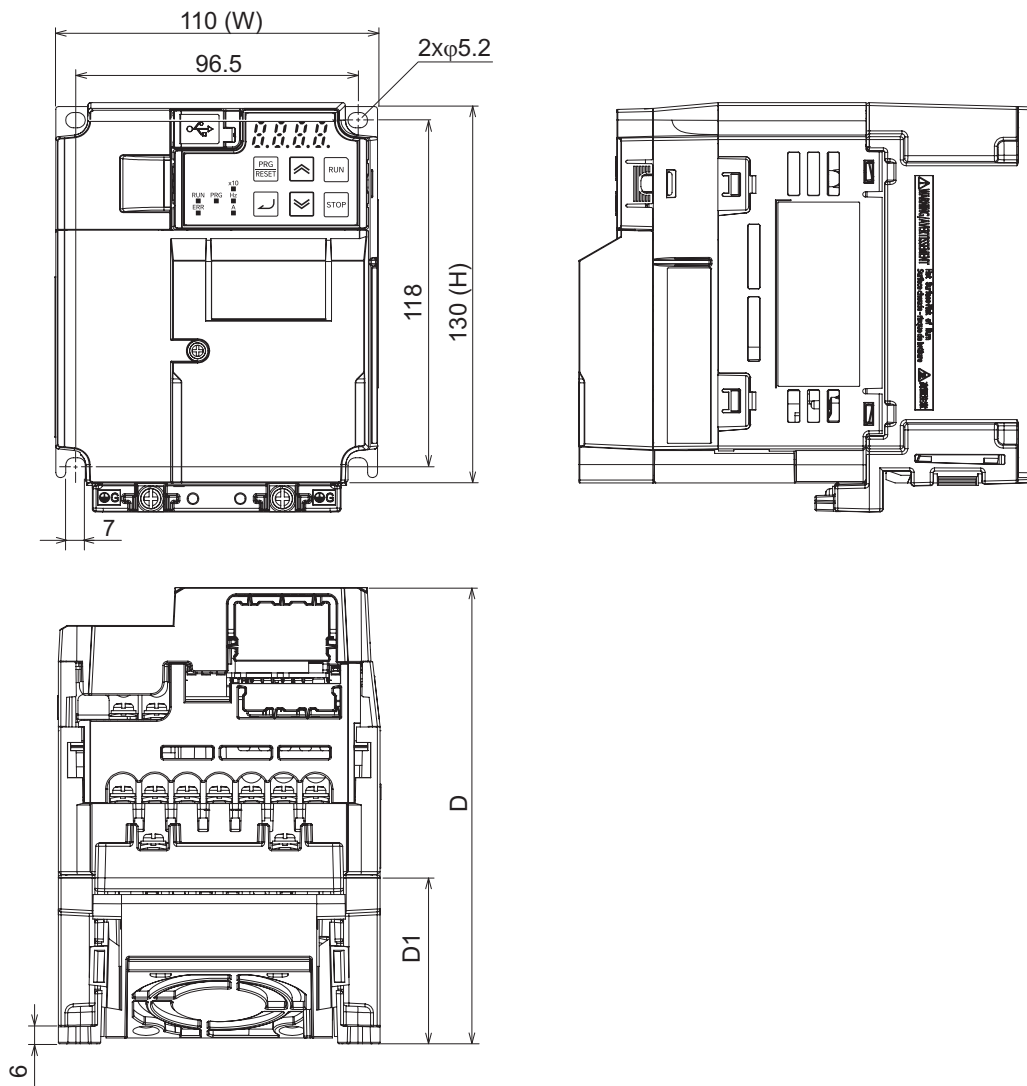

Power supply	Model	W [mm]	H [mm]	D [mm]	D1 [mm]
Single-phase 200 V	3G3M1-AB015	110	130	166	58
Three-phase 200 V	3G3M1-A2015 3G3M1-A2022			156	
Three-phase 400 V	3G3M1-A4004			132	38
	3G3M1-A4007 3G3M1-A4015 3G3M1-A4022			156	58

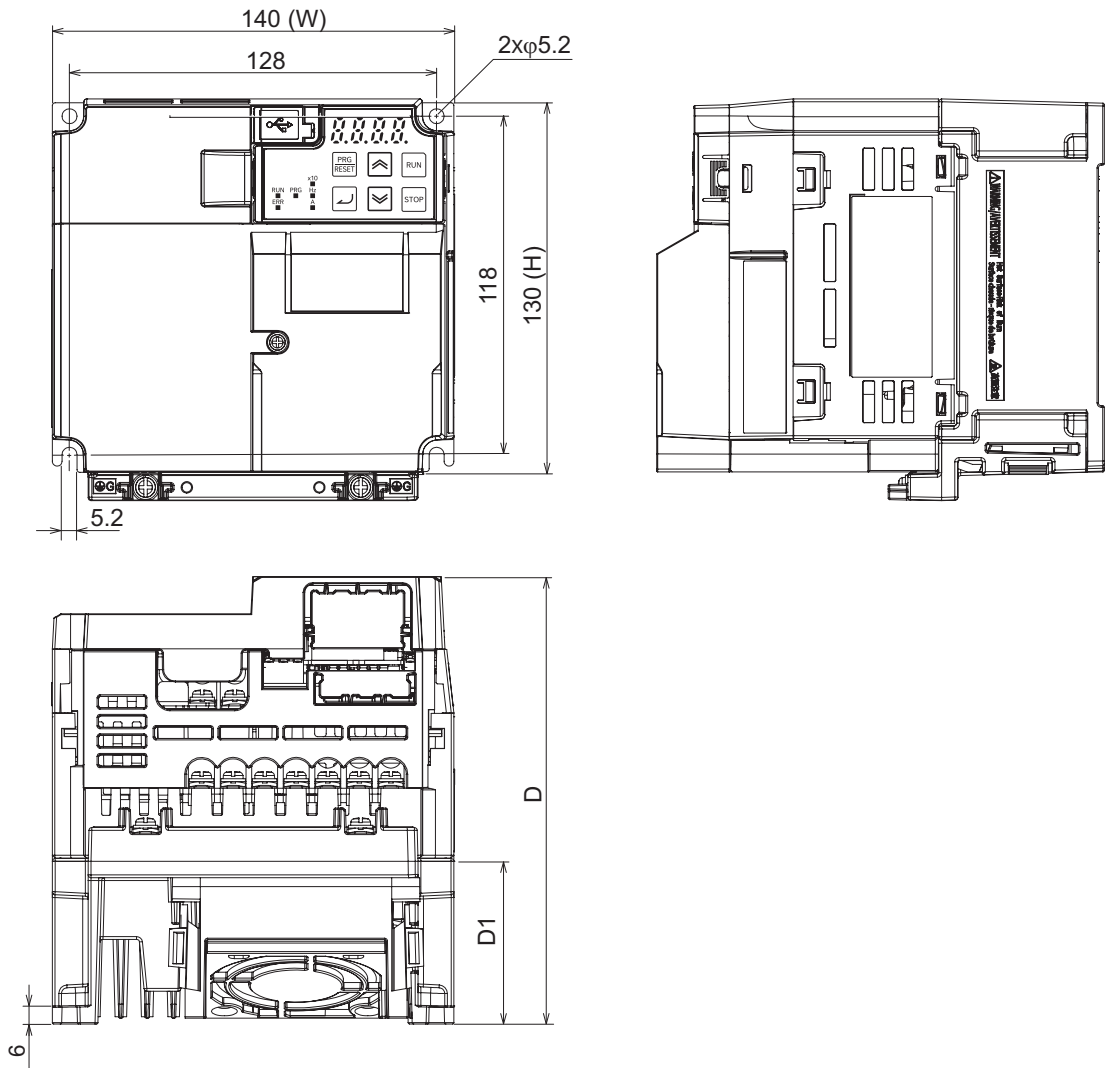

Power supply	Model	W [mm]	H [mm]	D [mm]	D1 [mm]
Single-phase 200 V	3G3M1-AB022	140	130	156	58
Three-phase 200 V	3G3M1-A2037				
Three-phase 400 V	3G3M1-A4030 3G3M1-A4040				

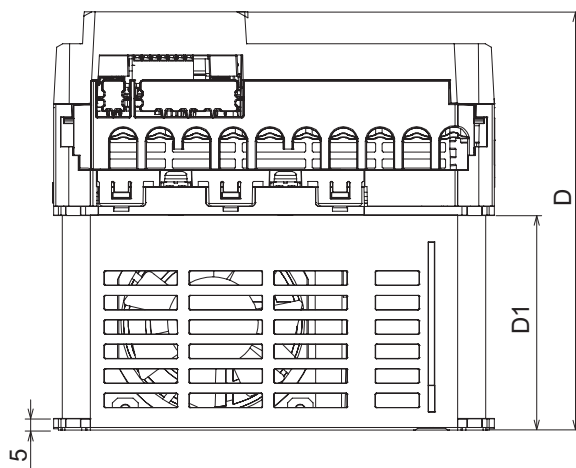
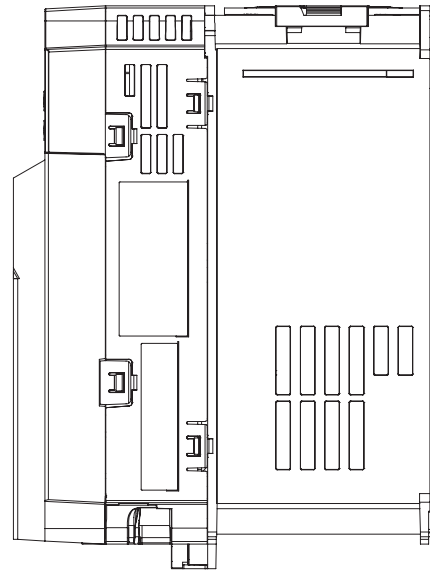
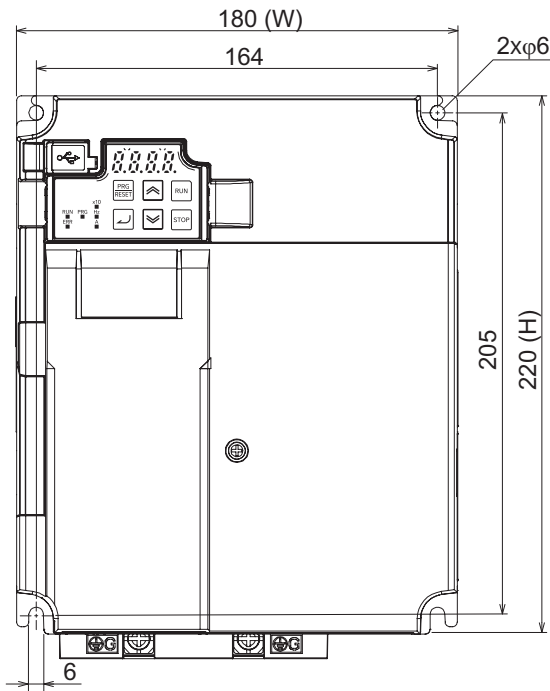

Power supply	Model	W [mm]	H [mm]	D [mm]	D1 [mm]
Single-phase 200 V	3G3M1-AB037	180	220	171	87.7
Three-phase 200 V	3G3M1-A2055 3G3M1-A2075				
Three-phase 400 V	3G3M1-A4055 3G3M1-A4075				

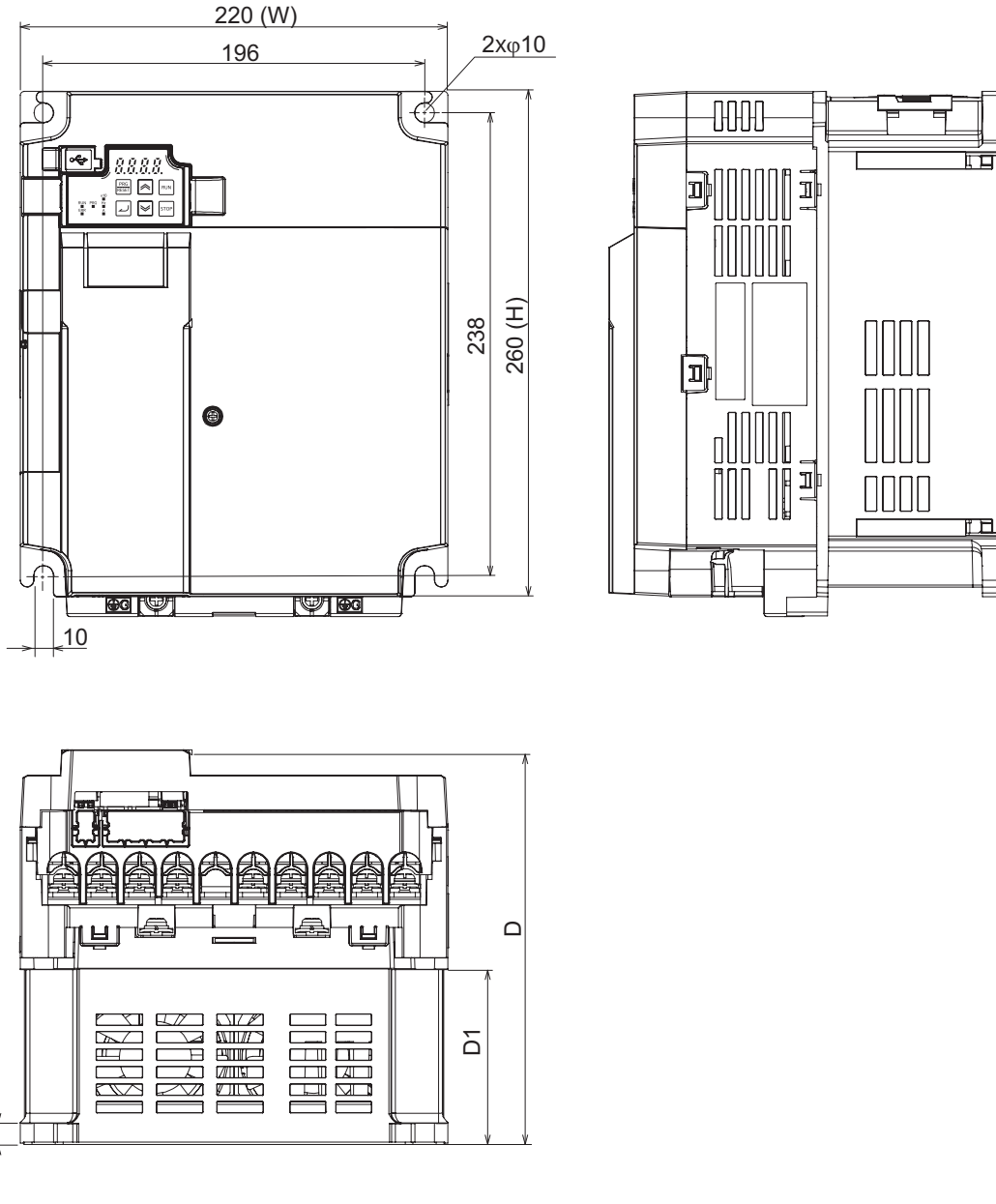

Power supply	Model	W [mm]	H [mm]	D [mm]	D1 [mm]
Three-phase 200 V	3G3M1-A2110	220	260	203	90
	3G3M1-A2150				
Three-phase 400 V	3G3M1-A4110				
	3G3M1-A4150				



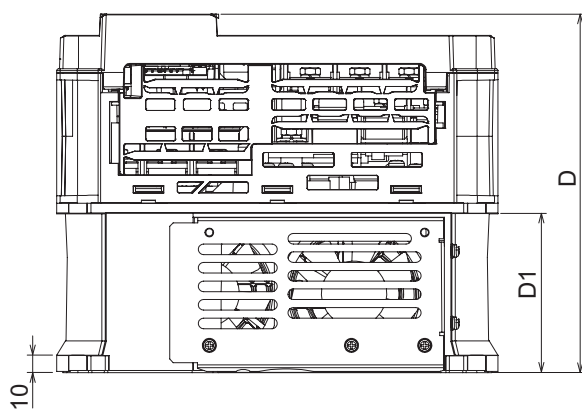
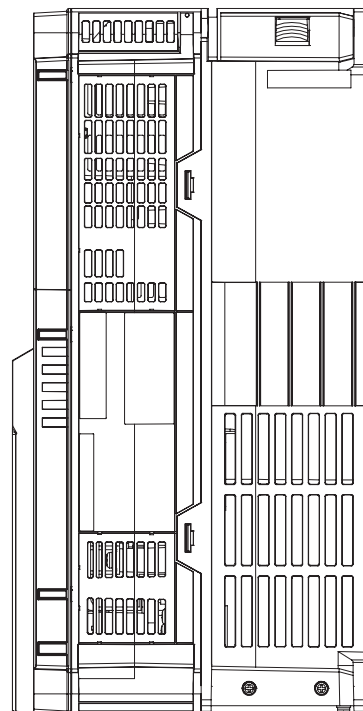
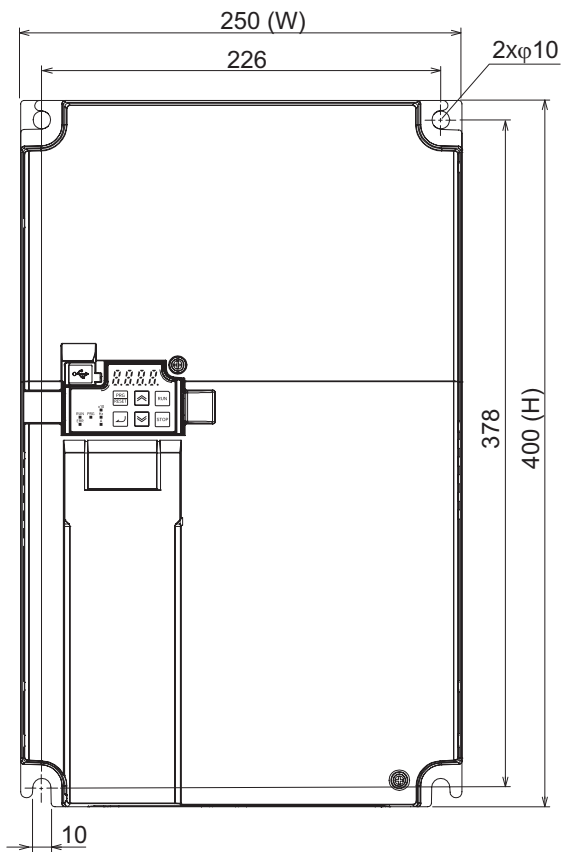

Power supply	Model	W [mm]	H [mm]	D [mm]	D1 [mm]
Three-phase 200 V	3G3M1-A2185	250	400	203	90
Three-phase 400 V	3G3M1-A4185 3G3M1-A4220				

# 1-4 Restrictions

## Availability of Functions by Individual Control Method

Available functions are restricted depending on the selected control method.

“15:PM Vector control without speed and pole position sensor” and “16:PM Vector control with speed and pole position sensor” can be set to only 1st motor control.

Function name	1st Drive Control Selection(F42)/2nd Drive Control Selection(A14)							
	0: IM V/f control	1: IM Dynamic torque vector control	3: IM V/f control with speed sensor	4: IM Dynamic torque vector control with speed sensor	5: IM Vector control without speed sensor	6: IM Vector control with speed sensor	15: PM Vector control without speed and pole position sensor	16: PM Vector control with speed and pole position sensor
Torque boost manual adjustment	Available	N/A	Available	Available	N/A	N/A	N/A	N/A
Invalidation of automatic voltage control (AVR)	Available	N/A	Available	Available	N/A	N/A	N/A	N/A
Energy-saving operation mode	Available	Available	Available	Available	N/A	Available	N/A	N/A
Motor sound (Tone)	N/A	N/A	N/A	N/A	Available	Available	Available	Available
Invalidation of slip compensation	Available	N/A	N/A	N/A	N/A	N/A	N/A	N/A
DC injection braking	Available	Available	Available	Available	Available	Available	N/A	N/A
Startup DC injection braking	Available	Available	Available	Available	N/A	N/A	N/A	N/A
Frequency pull-in restart	Available	Available	N/A	N/A	Available	N/A	N/A	N/A
Current limiter, instantaneous overcurrent limiting	Available	Available	Available	Available	N/A	N/A	N/A	N/A
Torque limit	Available	Available	Available	Available	Available	Available	Available	Available
Torque control	N/A	N/A	N/A	N/A	Available	Available	N/A	Available
Torque bias	N/A	N/A	N/A	N/A	Available	Available	Available	Available
Automatic speed control (ASR), Notch filter	N/A	N/A	N/A	N/A	Available	Available	Available	Available
Zero speed control	N/A	N/A	N/A	N/A	Available	Available	N/A	Available

Function name	1st Drive Control Selection(F42)/2nd Drive Control Selection(A14)							
	0: IM V/f control	1: IM Dynamic torque vector control	3: IM V/f control with speed sensor	4: IM Dynamic torque vector control with speed sensor	5: IM Vector control without speed sensor	6: IM Vector control with speed sensor	15: PM Vector control without speed and pole position sensor	16: PM Vector control with speed and pole position sensor
Servo lock	N/A	N/A	N/A	N/A	N/A	Available	N/A	Available
Deceleration characteristics (heavy brake)	Available	Available	Available	Available	N/A	Available	N/A	N/A
Pre-excitation	N/A	N/A	N/A	N/A	Available	Available	N/A	N/A
Overload stop (contact stop)	Available	Available	Available	Available	N/A	N/A	N/A	N/A
Second control switch	Available	Available	Available	Available	Available	Available	N/A	N/A
Brake control	Available	Available	Available	Available	Available	Available	N/A	Available

## Carrier Frequency Setting and Derating of Rated Output Current

Derating of the rated output current of the inverter may be required when a high carrier frequency is set, depending on the heavy/light load mode selection and operating temperature.

Use the inverter in an appropriate environment according to *A-1 Derating Table* on page A-2.



# 2

## Design

This section describes the installation environment and wiring methods.

---

<b>2-1</b>	<b>Installation .....</b>	<b>2-2</b>
2-1-1	Inverter Installation .....	2-2
2-1-2	Installation Environment .....	2-2
<b>2-2</b>	<b>Removal of Each Part .....</b>	<b>2-7</b>
2-2-1	Removing Covers .....	2-7
2-2-2	Terminal Blocks .....	2-8
2-2-3	Preparing Backing Plate .....	2-9
<b>2-3</b>	<b>Wiring .....</b>	<b>2-10</b>
2-3-1	Standard Connection Diagram .....	2-10
2-3-2	Arrangement and Function of Main Circuit Terminal Block .....	2-11
2-3-3	Arrangement and Function of Control Circuit Terminal Block .....	2-12
2-3-4	Wiring for Main Circuit Terminals .....	2-15
2-3-5	Wiring for Control Circuit Terminals .....	2-51
2-3-6	Recommended Encoder and Its Wiring .....	2-54
2-3-7	Wiring for RS-485 Communications Terminal Block .....	2-57
2-3-8	Safety Function .....	2-58
<b>2-4</b>	<b>Others .....</b>	<b>2-60</b>
2-4-1	Korean Radio Regulations (KC) .....	2-60
2-4-2	Compliance with EU Directives and UKCA .....	2-60
2-4-3	UL/cUL Standards Cautions .....	2-76

## 2-1 Installation

### 2-1-1 Inverter Installation

Mount the 3G3M1 Series Inverter vertically on a wall with the product's longer sides upright so the model can be read correctly.

The material of the wall must be inflammable and capable of bearing weight such as a metal plate.

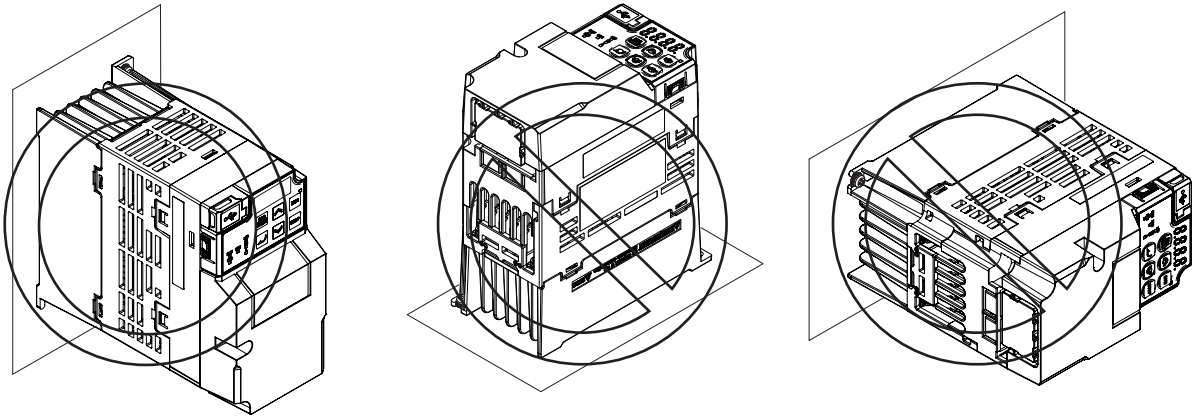

For the mounting dimensions, refer to 1-3-2 *External Dimensions* on page 1-18.

### 2-1-2 Installation Environment

#### Operating Environment Conditions

Install the inverter in a location that meets the following conditions.

Operating ambient temperature	Operating ambient humidity
-10 to 50°C	5% to 95% (with no condensation)

- Measure and check the ambient temperature at a point approx. 1 cm away from the center bottom of the inverter.
- For side-by-side installation, derating of the rated output current of the inverter may be required even at an ambient temperature of 40°C or lower.
- The inverter life (in particular, capacitor life) will be significantly shortened if the inverter is used at a higher ambient temperature.
- Do not install the inverter in hot and humid locations subject to condensation.
- Avoid installing the inverter in a dirty environment subject to oil mist, dust, or other airborne particles. Install the inverter in a clean place, or in a full-enclosure type panel.
- Take measures during installation and operation to prevent foreign objects such as metal particles, oil, and water from entering the inverter.
- Do not install the inverter in locations subject to direct sunlight.
- Do not install the inverter in locations subject to corrosive or flammable gases.

#### Installation Conditions

Keep the inverter clear of heating elements such as a braking resistor or reactor.

If the inverter is installed in a control panel, take into consideration dimensions and ventilation to keep the ambient temperature within the range of the specifications.

To allow heat dispersion from inside the inverter (approx. 150°C or lower), provide the clearance specified in the figure below during installation.

### ● Standard installation

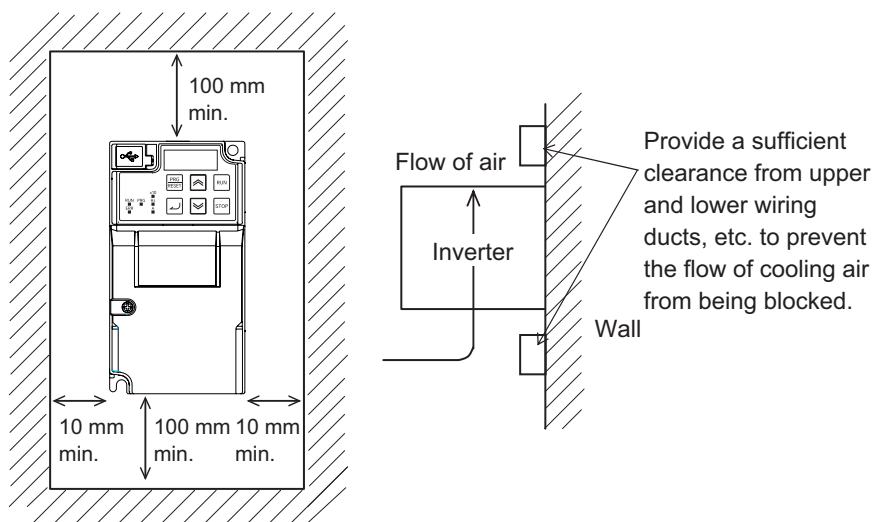

### ● Side-by-side installation

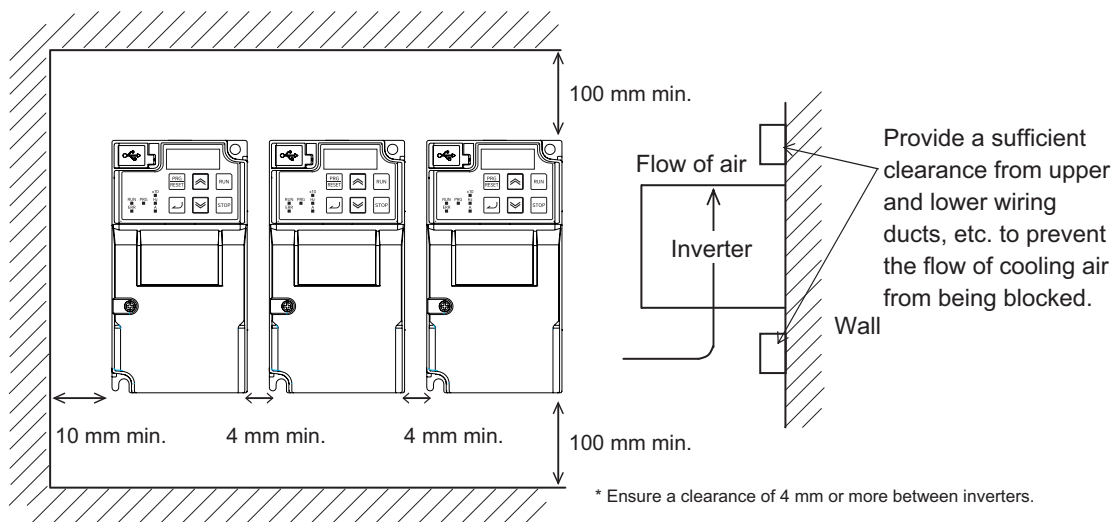

## Ambient Temperature Control

To ensure reliable operation, use the inverter in an environment subject to minimal temperature rise as much as possible.

If you install a ventilation fan in a control panel where several inverters are installed, be careful about the layout of the inverters and the air intake and ventilation apertures.

Remember that poor air circulation around inverters causes an internal temperature rise, which may inversely affect the internal components of the inverters.

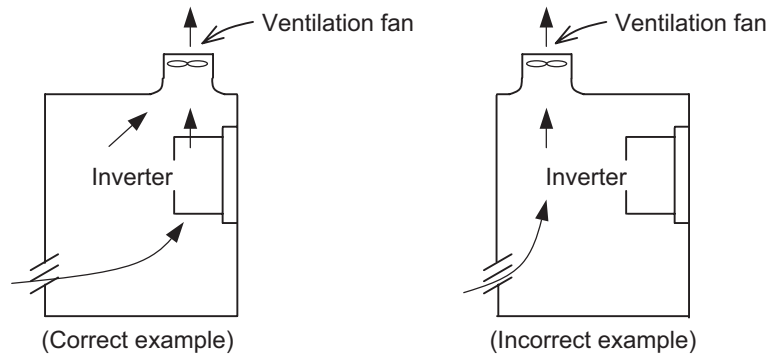

## Entry of Foreign Objects during Installation

Place a cover over the inverter or take other preventative measures to prevent foreign objects, such as drill filings, from entering the inverter during installation.

Be sure to remove the cover after installation is complete. Using the inverter with the cover placed results in poor ventilation, which causes the inverter to overheat.

## Heat generation by individual inverter model

The following table shows heat generation by individual inverter model for the calculation of heat radiation from a cabinet. Inverter heat generation also changes as the rated current changes according to the load mode.

Unit: W

Power system	Inverter type	Standby power	Carrier frequency (Parameter No.F26 (Object 3004Hex-1BHex) <sup>*1</sup> )					
			ND	HD	HND		HHD	
			Factory shipment value	Factory shipment value	Factory shipment value	Maximum set value	Factory shipment value	Maximum set value
Three-phase 200 V	3G3M1-A2001	13	-	-	19	22	17	20
	3G3M1-A2002	13	-	-	29	34	23	27
	3G3M1-A2004	13	-	-	47	51	35	39
	3G3M1-A2007	13	-	-	66	71	54	58
	3G3M1-A2015	17	-	-	94	115	74	95
	3G3M1-A2022	17	-	-	115	145	98	125
	3G3M1-A2037	17	-	-	210	285	165	230
	3G3M1-A2055	31	-	-	280	360	170	230



Power system	Inverter type	Standby power	Carrier frequency (Parameter No.F26 (Object 3004Hex-1BHex))*1					
			ND	HD	HND		HHD	
			Factory shipment value	Factory shipment value	Factory shipment value	Maximum set value	Factory shipment value	Maximum set value
Three-phase 200 V	3G3M1-A2075	31	-	-	440	540	280	360
	3G3M1-A2110	34	-	-	520	700	440	540
	3G3M1-A2150	31	-	-	640	810	520	700
	3G3M1-A2185	38	-	-	770	970	660	860
Three-phase 400 V	3G3M1-A4004	14	33	32	33	58	32	56
	3G3M1-A4007	14	57	50	57	110	50	93
	3G3M1-A4015	17	73	69	73	140	67	120
	3G3M1-A4022	17	98	95	98	180	79	145
	3G3M1-A4030	17	120	120	120	230	100	190
	3G3M1-A4040	17	155	150	150	265	130	240
	3G3M1-A4055	31	260	190	190	370	170	320
	3G3M1-A4075	31	380	290	290	510	220	390
	3G3M1-A4110	31	460	390	390	630	300	490
	3G3M1-A4150	31	470	410	410	750	340	600
	3G3M1-A4185	31	710	510	510	870	440	770
	3G3M1-A4220	31	900	710	710	1000	510	900

Power system	Inverter type	Standby power	Carrier frequency (Parameter No.F26 (Object 3004Hex-1BHex))*1					
			ND	HD	HND		HHD	
			Factory shipment value	Factory shipment value	Factory shipment value	Maximum set value	Factory shipment value	Maximum set value
Single-phase 200 V	3G3M1-AB001	13	-	-	19	21	17	20
	3G3M1-AB002	13	-	-	29	31	23	27
	3G3M1-AB004	13	-	-	47	50	36	40
	3G3M1-AB007	13	-	-	66	69	55	59
	3G3M1-AB015	17	-	-	94	110	78	100
	3G3M1-AB022	17	-	-	115	140	100	130
	3G3M1-AB037	31	-	-	-	-	165	230

- \*1. The inverter generating loss at rated output current.  
The maximum set value (max. carrier) differs depending on specification.

## 2-2 Removal of Each Part

### 2-2-1 Removing Covers

Before wiring each terminal block, you need to remove the surface cover (terminal block cover and the backing plate).

This section describes how to remove these covers.

#### Removing Terminal Block Cover

- 1 Loosen the terminal block cover fixation screw(s).
- 2 Remove the terminal block cover from the bottom.

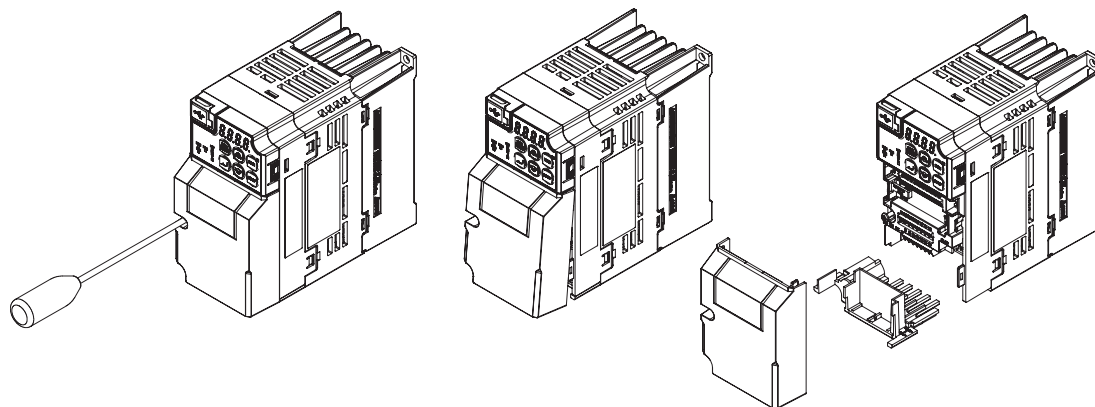

You can find one terminal block cover fixation screw at left center for inverters with a capacity of 0.75 kW or lower, center for inverters with a capacity of 1.5 to 15 kW, and bottom right for inverters with a capacity of 18.5 kW or higher.

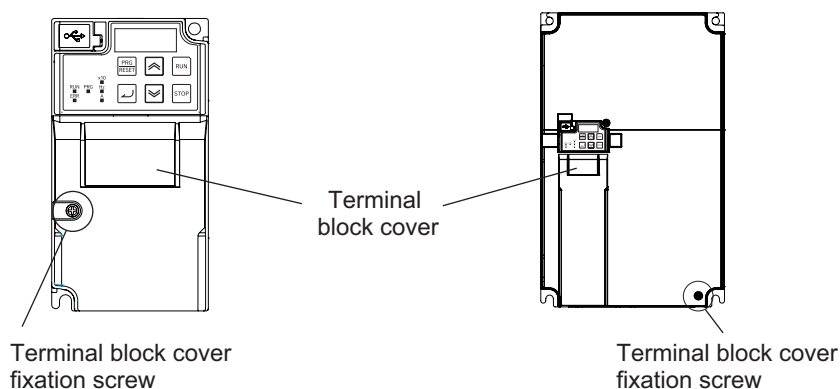

#### Installing Terminal Block Cover

To install the terminal block cover, reverse the removal procedure.

Install the terminal block cover on the inverter from the top and press it until you here a click.

Tighten the terminal block cover fixing screws with the tightening torque of 0.3 Nm.

## 2-2-2 Terminal Blocks

Removing the terminal block cover and each connector cover reveals terminal blocks, connectors, and switches arranged as shown below.

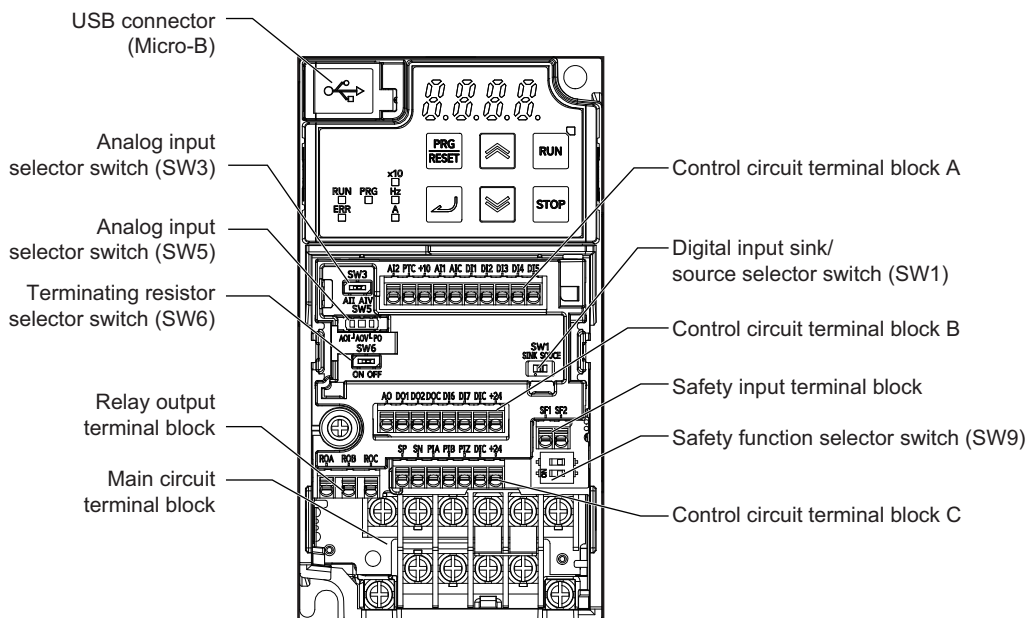

Name	Description
Digital input sink/source selector switch (SW1)	The switch for switching which of sink or source the digital input terminals DI1 to DI7 are to be used for. (Factory default setting is SINK side)
Analog input selector switch (SW3)	The switch for switching the input type of terminal AI2. (Factory default setting is All side) When set to the All side, input becomes analog current input. When set to the AIV side, input becomes analog voltage input.
Analog output selector switch (SW5)	The switch for switching the output type of terminal AO. (Factory default setting is AOV side) When set to the AOI side, output becomes analog current output. When set to the AOV side, output becomes analog voltage output. When set to the PO side, output becomes pulse output.
Terminating resistor selector switch (SW6)	The switch for switching ON/OFF the RS-485 terminal on the control circuit terminal block. When ON, the terminal is connected to the built-in 110-Ω terminating resistor. (Factory default setting is OFF side)
Safety function selector switch (SW9)	Turn this switch OFF to use the safety function. Before you turn ON/OFF this switch, be sure to turn off the power supply. For details, refer to 7-6 <i>Safety Function</i> on page 7-69. (Factory default setting is ON side (safety function disabled))
USB connector	The Micro-B type USB connector for connecting a computer. Use this connector to connect the inverter to the Inverter/Servo support tool Sysmac Studio.
Control circuit terminal block A, B, C	The terminal block for connecting various digital/analog I/O devices used for inverter control.
Safety input terminal block	The terminal block for connecting the safety input signal.
Relay output terminal block	The SPDT contact terminal block for relay output.
Main circuit terminal block	The terminal block for connecting the main power supply for the inverter, outputs to the motor, braking resistor, etc.

**Note** For the description of the data display and operation keys, refer to *Section 3 Operation and Test Run* on page 3-1.

### 2-2-3 Preparing Backing Plate

On some models, sometimes there is not enough space for wiring the main circuit. If this happens, before wiring, cut off the connecting points between the backing plate and unnecessary portions with nippers or a wire cutter.

Note that IP20 protection is no longer ensured when using the product with backing plate removed.

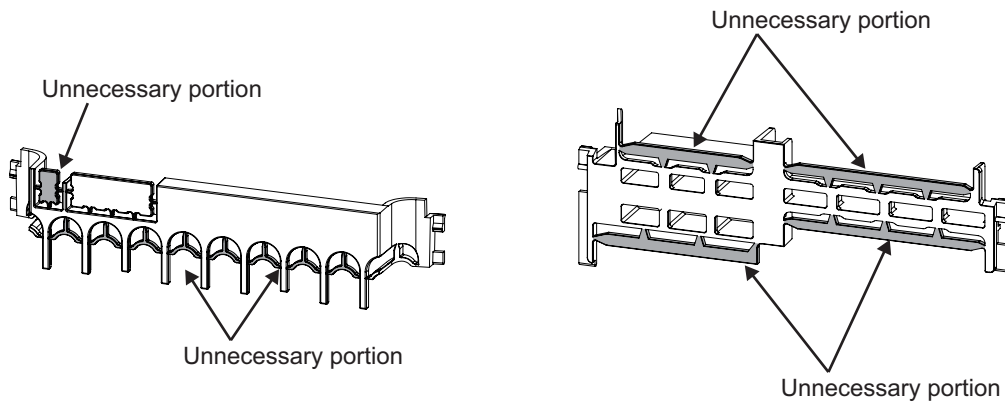

# 2-3 Wiring

## 2-3-1 Standard Connection Diagram

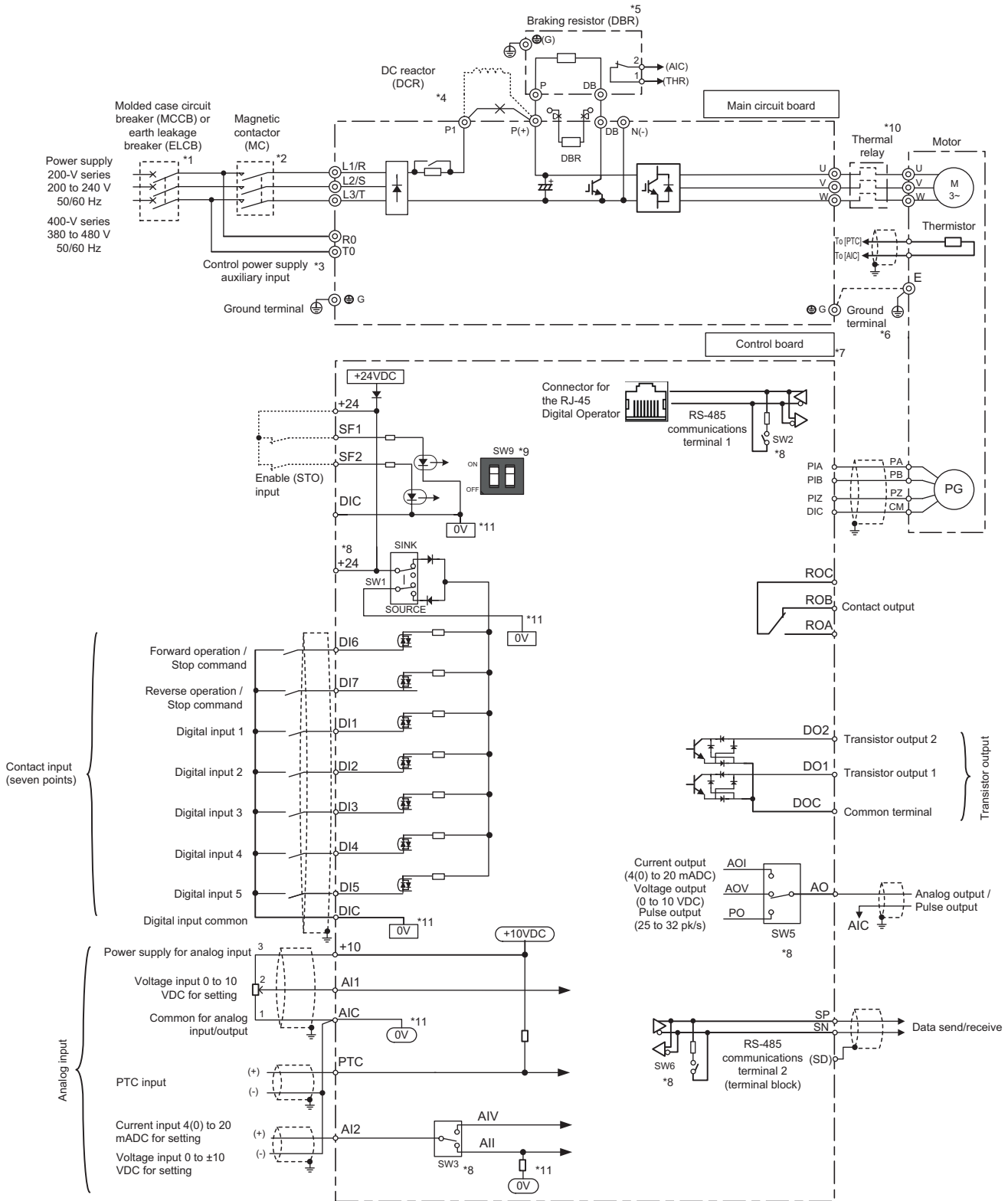

\*1. To protect the wiring, install a molded case circuit breaker (MCCB) or earth leakage circuit breaker (ELCB) (with overcurrent protection function) recommended for each inverter on the inverter input side (primary side). Do not use circuit breakers whose rated current exceeds recommended values.

- \*2. The molded case circuit breaker and earth leakage circuit breaker are also used for insulation from the inverter's power supply. For this reason, install a magnetic contactor (MC) recommended for each inverter as required. When installing a magnetic contactor and solenoid or other coil near an inverter, connect surge absorbers in parallel.
- \*3. To enable a batch alarm signal when the protection function is activated even if the main power supply of the inverter is cut off or to display the Digital Operator at all times, connect these terminals to the power supply. (3G3M1-A2185 or later or 3G3M1-A4185 or later products) The inverter operates even when these terminals are not connected to the power supply.
- \*4. When connecting the optional DC reactor (DCR), remove the short-circuit bar between the main circuit terminals P1 and P(+) of the inverter before connecting.  
When the capacity of the power transformer is 500 kVA or more and 10 times or more than the rated capacity of the inverter, or when a thyristor load is connected, use a DC reactor (DCR).
- \*5. As a transistor for braking is built into the inverter, the braking resistor can be directly connected between P(+) and DB.
- \*6. The terminal for grounding the motor. Connect this terminal, as required.
- \*7. Use twisted wire or shield wire for the control signal wire.  
Generally, shield wire is grounded. However, when inductive noise from an external source is large, the influence of noise can sometimes be suppressed by connecting the shield wire to a DIC. Separate control signal wire as far as possible (at least 10 cm is recommended) from the wiring of the main circuit, and do not pass control signal wire through the same wiring duct. When wires cross, be sure to cross them so that they are almost vertical to the wiring of the main circuit.
- \*8. This switch on the printed circuit board is for specifying the operation setting of the inverter. For details, refer to 2-2-2 *Terminal Blocks* on page 2-8.
- \*9. Safety function terminals SF1 and SF2 are disabled at SW9 (double-pole switch) on the printed circuit board before shipment from the factory. When using the SF1 and SF2 terminal functions, be sure to turn each SW9 switch OFF before connecting to these terminals.
- \*10. Cut off the molded case circuit breaker (MCCB) or magnetic contactor (MC) at the auxiliary contact (manual reset) of the thermal relay.
- \*11.  $\boxed{0V}$  and  $\textcircled{0V}$  are separated and insulated.

## 2-3-2 Arrangement and Function of Main Circuit Terminal Block

The table below shows the arrangement of the main circuit terminal block and description of each terminal.

### Main Circuit Terminal Block

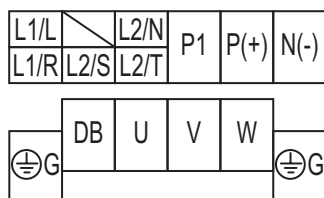

The terminal arrangement shown on the left is an example for the inverters with a capacity of 0.75 kW or lower.

Terminal symbol		Terminal name	Description
L1/R	L1/L	Main power supply input terminal	Connect the AC input power supply. For single-phase 200-V type Inverters (3G3M1-AB□□□), connect these to the L1/L and L2/N terminals, respectively.
L2/S			
L3/T	L2/N		
U		Inverter output terminal	Connect a three-phase motor.
V			
W			

Terminal symbol	Terminal name	Description
P1	DC reactor connection terminal	Remove the short-circuit bar between the terminals P1 and P(+), and connect an optional DC reactor.
P(+)		
P(+)	Braking resistor connection terminal	Connect an optional braking resistor (if a braking torque is required).
DB		
P(+)	Regenerative braking unit connection terminal	Connect optional regenerative braking units (if a braking torque is required and that produced by the built-in braking circuit is insufficient).
N(-)		
R0, T0	Control power supply auxiliary input	To hold a batch alarm signal when the protection function is activated even if the main power supply of the inverter is cut off or to display the Digital Operator at all times, connect these terminals to the power supply (at a capacity of 1.85 kW or more, for details, refer to 2-3-4 <i>Wiring for Main Circuit Terminals</i> on page 2-15).
G ⊕	Ground terminal	This is the ground terminal. Connect this terminal to the ground. 200-V class should be connected under type-D grounding conditions; 400-V class should be connected under type-C grounding conditions.

### 2-3-3 Arrangement and Function of Control Circuit Terminal Block

The table below shows the arrangement of the control circuit terminal block, and description and specifications of each terminal.

#### Control Circuit Terminal Block

AI2	PTC	+10	AI1	AIC	DI1	DI2	DI3	DI4	DI5		
AO	DO1	DO2	DOC	DI6	DI7	DIC	+24				
ROA	ROB	ROC	SP	SN	PIA	PIB	PIZ	DIC	+24	SF1	SF2



Item		Terminal symbol	Terminal name	Description	Specifications	
Analog	Input	+10	Power supply for analog input	This is a 10 VDC power supply for the AI1 terminal.	Maximum allowable current: 10 mA	
		AI1	Analog voltage input	This is a -10 to 10 VDC analog voltage input.	Input impedance: 22 k $\Omega$ Allowable input voltage range: -15 to 10 VDC	
		AI2	(AII)	Analog current input	This is a 4 to 20 mA DC analog current input.	Input impedance: 250 $\Omega$ Allowable input range: 0 to 30 mA
			(AIV)	Analog voltage input	This is a 0 to 10 VDC analog voltage input.	Input impedance: 22 k $\Omega$ Allowable input voltage range: -15 to 10 VDC
		AIC	Analog input common	Common terminal for the analog input.		
		PTC	External thermistor input	Connect an external thermistor between the PTC and the AIC, and when an abnormal temperature is reached, an inverter trip is generated. (Set the inverter trip level at parameter H27.)	PTC type	
	Output	AO	(AOV)	Multi-function analog output (Voltage)	This terminal can output the specified signal as a 0 to 10 VDC voltage signal.	Input impedance: Approx. 5 k $\Omega$
			(AOI)	Multi-function analog output (Current)	This terminal can output the specified signal as a 4 to 20 mA current signal.	Input impedance: Approx. 500 $\Omega$
			(PO)	Multi-function analog output (Pulse output)	Output a pulse.	Output pulse: 32 kHz max. Output voltage: 11 VDC Allowable current: 2 mA max.

Item		Terminal symbol	Terminal name	Description	Specifications	
Digital	Power supply	DIC	Input signal common	Common terminal for the digital input.		
	Input	Contact	D11 D12 D13 D14 D15 D16 D17	Multifunction input terminal	Select 7 functions from among 101 functions, and allocate them to terminals D11 to D17. These terminals support both the sink logic and the source logic. For details on the connection, refer to <i>Multifunction Input Terminals and Programmable Controller Connection</i> on page 2-53.	Voltage between each input terminal and the terminal DIC ON voltage: 20 V min. OFF voltage: 2 V max. Allowable voltage: 27 VDC max. Load current (D11, D12): 2.5 to 16 mA (at 27 V) Load current (D13 to D17): 2.5 to 5 mA (at 27 V) Internal resistance: 5.4 kΩ
			SF1 SF2	Safety input	Turn ON the Safety Function Selector Switch to enable this terminal. SF1 (Safety input 1) SF2 (Safety input 2)	Voltage between each input terminal and the terminal DIC ON voltage: 20 V min. OFF voltage: 2 V max. Allowable voltage: 27 VDC max. Load current: 2.5 to 5 mA (at 27 V) Internal resistance: 6.6 kΩ
	Pulse	PIA PIB PIZ	Pulse input	This is pulse input for frequency setting. This terminal accepts 5 to 24 VDC input signals.	Input pulse: 32 kHz max. Internal resistance: 7.2 kΩ Voltage between input and DIC: 5 to 24 VDC ON voltage: 4 V min. OFF voltage: 2 V max. Allowable voltage: 27 VDC max.	

Item			Terminal symbol	Terminal name	Description	Specifications
Digital	Out-put	Open collec-tor	+24	Power supply terminal for output signal	This is a 24 VDC power supply for the output signal.	Allowable current: 100 mA max.
			DOC	Output signal common	Common terminal for multifunction output terminals DO1 and DO2.	Allowable current: 100 mA max.
			DO1 DO2	Multifunction output terminal	Select 2 functions from among 92 functions, and allocate them to terminals DO1 and DO2. These terminals support both the sink logic and the source logic. For details on the connection, refer to <i>Multifunction Output Terminals and Programmable Controller Connection</i> on page 2-54.	Open collector output Between each terminal and DOC Allowable voltage: 48 VDC max. Allowable current: 50 mA max. Voltage drop at power-on: 4 V max.
Serial communications			SP SN	Modbus terminal (RS-485)	RS-485 terminal SP RS-485 differential (+) signal SN RS-485 differential (-) signal	Speed: 115.2 kbps max. Cable length: 500 m max. Built-in terminating resistor: 110 Ω Switching via slide switch
Multi-function relay output			ROA ROB ROC	Relay output terminal Relay output common	Select the desired function from among 92 functions, and allocate it to these terminals. This is SPDT contact output. Factory default values are NO contact between ROA-ROC and NC contact between ROB-ROC.	250 VAC, 0.3 A, cosφ=0.3/48 VDC, 0.5 A

## 2-3-4 Wiring for Main Circuit Terminals

### Main Circuit Configuration Diagram

The diagram below shows the configuration of the inverter main circuit. The function of each peripheral component is also described.

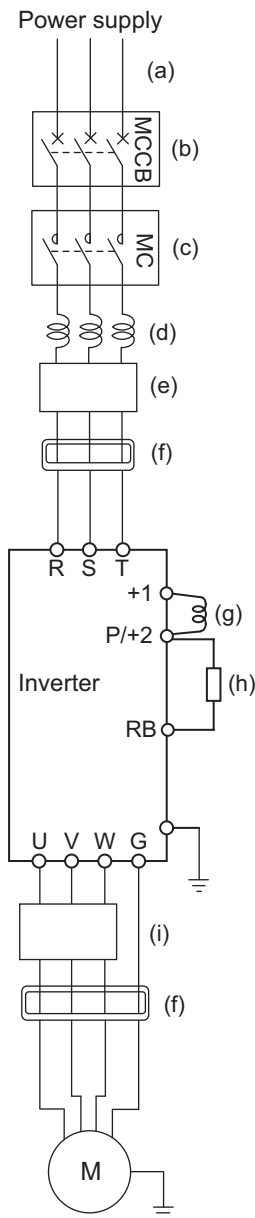

Name	Function
(a) (b) (c)	Refer to <i>Recommended Cable Size, Wiring Device, and Crimp Terminal</i> on page 2-18.
(d) AC reactor	This is used as a harmonic suppression measure. It also helps improve the power factor. The AC reactor is used when the power supply voltage unbalance factor is 3% or more, the inverter capacity is 500 kVA or more, or rapid change in the power supply voltage occurs to reduce its effect.
(e) Input noise filter	This filter reduces the conductive noise generated in the inverter and transmitted via wires. Connect it to the primary side (input side) of the inverter.
(f) Radio noise filter	The inverter in operation may cause noise through the power supply wiring etc., which could affect radio receivers or other equipment nearby. This filter reduces such noise (radiated noise).
(g) DC reactor	This reactor helps suppress harmonics generated by the inverter.
(h) Braking resistor	These increase the amount of regenerative energy absorption when the inverter applies motor braking and are used to decrease the speed of an elevator or load with a large moment of inertia. All models of the 3G3M1 Series Inverter have built-in regenerative braking processing circuit. The regenerative braking unit is necessary only if a large braking torque is required and the built-in regenerative braking processing circuit cannot allow it.
(j) Output noise filter	This filter is installed between the inverter and the motor to reduce the radiated noise emitted from cables. It is used to reduce radio and television interference and prevent meter and sensor malfunction.

## Arrangement of Main Circuit Terminals

The arrangement of terminals on the inverter main circuit terminal block is shown below.

Applicable model	Terminal arrangement
3G3M1-AB001/ AB002/AB004/AB007 3G3M1-A2001/ A2002/A2004/A2007	<p>(For single-phase class, connect L1/L to L1/R and L2/N to L3/T.)</p>
3G3M1-AB015 3G3M1-A2015/A2022 3G3M1-A4004/ A4007/A4015/A4022	<p>(For single-phase class, connect L1/L to L1/R and L2/N to L3/T.)</p>
3G3M1-AB022 3G3M1-A2037 3G3M1-A4030/A4040	<p>(For single-phase class, connect L1/L to L1/R and L2/N to L3/T.)</p>

Applicable model	Terminal arrangement
3G3M1-AB037 3G3M1-A2055/A2075 3G3M1-A4055/A4075	<p>(For single-phase class, connect L1/L to L1/R and L2/N to L3/T.)</p>
3G3M1-A2110/A2150 3G3M1-A4110/A4150	
3G3M1-A2185 3G3M1-A4185/A4220	

## Recommended Cable Size, Wiring Device, and Crimp Terminal

For inverter wiring, crimp terminal, and terminal screw tightening torque, refer to the table below.

- Each table shows an example of connecting the standard three-phase motor with four poles to an inverter.
- For the molded case circuit breaker (MCCB), select an appropriate product in consideration of the breaking capacity.

- For compliance with the UL standard requirements, be sure to perform wiring according to *2-4-3 UL/cUL Standards Cautions* on page 2-76, which includes the use of UL-compliant specified fuses and specified wiring materials.
- Tighten the terminal block screws with the specified torque. Weak tightening may result in a short-circuiting accident or fire. Conversely, overtightening these screws may cause damage to the terminal block or the inverter.

● **Three-phase 200-V class (Panel internal temperature 50°C or less)**

Model		Maximum applicable motor capacity [kW]	Recommended wire size [mm <sup>2</sup> ]							
			Main power supply input (L1/R, L2/S, L3/T)							
When DC reactor (DCR) is used				Without DC reactor						
HHD mode	HND mode		Allowable temperature (Note 1)			Current value [A]	Allowable temperature (Note 1)			Current value [A]
		60°C	75°C	90°C	60°C		75°C	90°C		
3G3M1-A2001	-	0.1	2.0	2.0	2.0	0.6	2.0	2.0	2.0	1.1
3G3M1-A2002	3G3M1-A2001	0.2	2.0	2.0	2.0	0.9	2.0	2.0	2.0	1.8
-	3G3M1-A2002	0.4	2.0	2.0	2.0	1.6	2.0	2.0	2.0	2.6
3G3M1-A2004	-		2.0	2.0	2.0	1.6	2.0	2.0	2.0	3.1
-	3G3M1-A2004	0.75	2.0	2.0	2.0	3.0	2.0	2.0	2.0	4.9
3G3M1-A2007	-		2.0	2.0	2.0	3.0	2.0	2.0	2.0	5.3
-	3G3M1-A2007	1.1	2.0	2.0	2.0	4.3	2.0	2.0	2.0	6.7
3G3M1-A2015	-	1.5	2.0	2.0	2.0	5.7	2.0	2.0	2.0	9.5
-	3G3M1-A2015	2.2	2.0	2.0	2.0	8.3	2.0	2.0	2.0	12.8
3G3M1-A2022	-		2.0	2.0	2.0	8.3	2.0	2.0	2.0	13.2
-	3G3M1-A2022	3	2.0	2.0	2.0	11.7	3.5	2.0	2.0	17.9
3G3M1-A2037	-	3.7	2.0	2.0	2.0	14.0	5.5	2.0	2.0	22.2
-	3G3M1-A2037	5.5	3.5	2.0	2.0	19.9	8.0	3.5	2.0	28.5
3G3M1-A2055	-		5.5	2.0	2.0	21.1	8.0	3.5	3.5	31.5
3G3M1-A2075	3G3M1-A2055	7.5	8.0	3.5	2.0	28.8	14.0	5.5	5.5	42.7
3G3M1-A2110	3G3M1-A2075	11	14.0	5.5	5.5	42.2	22.1	14.0	8.0	60.7
3G3M1-A2150	3G3M1-A2110	15	22.0	14.0	8.0	57.6	38.0	14.0	14.0	80.0
3G3M1-A2220	3G3M1-A2150	18.5	38.0 <sup>*1</sup>	14.0	14.0	71.0	60.0 <sup>*2</sup>	22.0	14.0	97.0
-	3G3M1-A2220	22	38.0 <sup>*1</sup>	22.0	14.0	84.4	60.0 <sup>*2</sup>	38.0 <sup>*1</sup>	22.0	112.0

Model		Maximum applicable motor capacity [kW]	Recommended wire size [mm <sup>2</sup> ]							
			Inverter output (U, V, W)							
HHD mode				HND mode						
HHD mode	HND mode		Allowable temperature (Note 1)			Current value [A]	Allowable temperature (Note 1)			Current value [A]
		60°C	75°C	90°C	60°C		75°C	90°C		
3G3M1-A2001	-	0.1	2.0	2.0	2.0	1.0	-	-	-	-
3G3M1-A2002	3G3M1-A2001	0.2	2.0	2.0	2.0	1.6	2.0	2.0	2.0	1.3

Model		Maximum applicable motor capacity [kW]	Recommended wire size [mm <sup>2</sup> ]							
			Inverter output (U, V, W)							
HHD mode	HND mode		HHD mode				HND mode			
			Allowable temperature (Note 1)			Current value [A]	Allowable temperature (Note 1)			Current value [A]
		60°C	75°C	90°C	60°C		75°C	90°C		
-	3G3M1-A2002	0.4	-	-	-	-	2.0	2.0	2.0	2.0
3G3M1-A2004	-		2.0	2.0	2.0	3.0	-	-	-	-
-	3G3M1-A2004	0.75	-	-	-	-	2.0	2.0	2.0	3.5
3G3M1-A2007	-		2.0	2.0	2.0	5.0	-	-	-	-
-	3G3M1-A2007	1.1	-	-	-	-	2.0	2.0	2.0	6.0
3G3M1-A2015	-	1.5	2.0	2.0	2.0	8.0	-	-	-	-
-	3G3M1-A2015	2.2	-	-	-	-	2.0	2.0	2.0	9.6
3G3M1-A2022	-		2.0	2.0	2.0	11.0	-	-	-	-
-	3G3M1-A2022	3	-	-	-	-	2.0	2.0	2.0	12.0
3G3M1-A2037	-	3.7	3.5	2.0	2.0	17.5	-	-	-	-
-	3G3M1-A2037	5.5	-	-	-	-	3.5	2.0	2.0	19.6
3G3M1-A2055	-		5.5	3.5	2.0	25.0	-	-	-	-
3G3M1-A2075	3G3M1-A2055	7.5	8.0	3.5	3.5	33.0	8.0	3.5	2.0	30.0
3G3M1-A2110	3G3M1-A2075	11	14.0	8.0	5.5	47.0	14.0	5.5	3.5	40.0
3G3M1-A2150	3G3M1-A2110	15	22.0	14.0	8.0	60.0	22.0	14.0	5.5	56.0
3G3M1-A2220	3G3M1-A2150	18.5	38.0*1	14.0	14.0	76.0	38.0*1	14.0	8.0	69.0
-	3G3M1-A2220	22	-	-	-	-	38.0*1	22.0	14.0	88.0

Model		Maximum applicable motor capacity [kW]	Recommended wire size [mm <sup>2</sup> ]			
			DC reactor connection (P1, P(+))			
HHD mode	HND mode		Allowable temperature (Note 1)			Current value [A]
			60°C	75°C	90°C	
		60°C	75°C	90°C	Current value [A]	
3G3M1-A2001	-	0.1	2.0	2.0	2.0	0.7
3G3M1-A2002	3G3M1-A2001	0.2	2.0	2.0	2.0	1.1
-	3G3M1-A2002	0.4	2.0	2.0	2.0	2.0
3G3M1-A2004	-		2.0	2.0	2.0	2.0
-	3G3M1-A2004	0.75	2.0	2.0	2.0	3.7
3G3M1-A2007	-		2.0	2.0	2.0	3.7
-	3G3M1-A2007	1.1	2.0	2.0	2.0	5.3
3G3M1-A2015	-	1.5	2.0	2.0	2.0	7.0
-	3G3M1-A2015	2.2	2.0	2.0	2.0	10.2
3G3M1-A2022	-		2.0	2.0	2.0	10.2
-	3G3M1-A2022	3	2.0	2.0	2.0	14.3
3G3M1-A2037	-	3.7	3.5	2.0	2.0	17.1
-	3G3M1-A2037	5.5	5.5	3.5	2.0	24.4
3G3M1-A2055	-		5.5	3.5	2.0	25.8



Model		Maximum applicable motor capacity [kW]	Recommended wire size [mm <sup>2</sup> ]			
			DC reactor connection (P1, P(+))			
HHD mode	HND mode		Allowable temperature (Note 1)			Current value [A]
		60°C	75°C	90°C		
3G3M1-A2075	3G3M1-A2055	7.5	14.0	5.5	3.5	35.3
3G3M1-A2110	3G3M1-A2075	11	22.0	8.0	5.5	51.7
3G3M1-A2150	3G3M1-A2110	15	38.0	14.0	14.0	70.5
3G3M1-A2220	3G3M1-A2150	18.5	38.0 <sup>*1</sup>	22.0	14.0	87.0
-	3G3M1-A2220	22	60.0 <sup>*2</sup>	22.0	22.0	103.4

Model		Maximum applicable motor capacity [kW]	Recommended wire size [mm <sup>2</sup> ]							
			Brake resistance connection (P(+), DB)							
HHD mode	HND mode		HHD mode				HND mode			
		Allowable temperature (Note 1)			Current value [A]	Allowable temperature (Note 1)			Current value [A]	
60°C	75°C	90°C	60°C	75°C		90°C				
3G3M1-A2001	-	0.1	2.0	2.0	2.0	0.3	-	-	-	-
3G3M1-A2002	3G3M1-A2001	0.2	2.0	2.0	2.0	0.4	2.0	2.0	2.0	0.3
-	3G3M1-A2002	0.4	-	-	-	-	2.0	2.0	2.0	0.4
3G3M1-A2004	-	0.75	2.0	2.0	2.0	0.5	-	-	-	-
-	3G3M1-A2004		-	-	-	-	2.0	2.0	2.0	0.6
3G3M1-A2007	-		2.0	2.0	2.0	0.7	-	-	-	-
-	3G3M1-A2007	1.1	-	-	-	-	2.0	2.0	2.0	0.8
3G3M1-A2015	-	1.5	2.0	2.0	2.0	1.4	-	-	-	-
-	3G3M1-A2015	2.2	-	-	-	-	2.0	2.0	2.0	1.5
3G3M1-A2022	-	3	2.0	2.0	2.0	1.7	-	-	-	-
-	3G3M1-A2022		-	-	-	-	2.0	2.0	2.0	1.7
3G3M1-A2037	-	3.7	2.0	2.0	2.0	2.4	-	-	-	-
-	3G3M1-A2037	5.5	-	-	-	-	2.0	2.0	2.0	2.5
3G3M1-A2055	-	7.5	2.0	2.0	2.0	3.8	-	-	-	-
3G3M1-A2075	3G3M1-A2055		2.0	2.0	2.0	5.0	2.0	2.0	2.0	3.8
3G3M1-A2110	3G3M1-A2075	11	2.0	2.0	2.0	7.5	2.0	2.0	2.0	5.3
3G3M1-A2150	3G3M1-A2110	15	2.0	2.0	2.0	9.4	2.0	2.0	2.0	7.5
3G3M1-A2220	3G3M1-A2150	18.5	2.0	2.0	2.0	12.7	2.0	2.0	2.0	9.0
-	3G3M1-A2220	22	2.0	2.0	2.0	13.8	-	-	-	-

Model		Maximum applicable motor capacity [kW]	Recommended wire size [mm <sup>2</sup> ]		
HHD mode	HND mode		Inverter ground (G)		
			Allowable temperature (Note 1)		
			60°C	75°C	90°C
3G3M1-A2001	-	0.1	2.0	2.0	2.0
3G3M1-A2002	3G3M1-A2001	0.2	2.0	2.0	2.0
-	3G3M1-A2002	0.4	2.0	2.0	2.0
3G3M1-A2004	-		2.0	2.0	2.0
-	3G3M1-A2004	0.75	2.0	2.0	2.0
3G3M1-A2007	-		2.0	2.0	2.0
-	3G3M1-A2007	1.1	2.0	2.0	2.0
3G3M1-A2015	-	1.5	2.0	2.0	2.0
-	3G3M1-A2015	2.2	2.0	2.0	2.0
3G3M1-A2022	-		2.0	2.0	2.0
-	3G3M1-A2022	3	2.0	2.0	2.0
3G3M1-A2037	-	3.7	2.0	2.0	2.0
-	3G3M1-A2037	5.5	3.5	3.5	3.5
3G3M1-A2055	-		3.5	3.5	3.5
3G3M1-A2075	3G3M1-A2055	7.5	5.5	5.5	5.5
3G3M1-A2110	3G3M1-A2075	11	5.5	5.5	5.5
3G3M1-A2150	3G3M1-A2110	15	5.5	5.5	5.5
3G3M1-A2220	3G3M1-A2150	18.5	8.0	8.0	8.0
-	3G3M1-A2220	22	8.0	8.0	8.0

● Three-phase 400-V class (Panel internal temperature 50°C or less)

Model		Maximum applicable motor capacity [kW]	Recommended wire size [mm <sup>2</sup> ]							
HHD mode	HND mode		Main power supply input (L1/R, L2/S, L3/T)							
			When DC reactor (DCR) is used				Without DC reactor (DCR)			
			Allowable temperature (Note 1)			Current value [A]	Allowable temperature (Note 1)			Current value [A]
			60°C	75°C	90°C		60°C	75°C	90°C	
3G3M1-A4004	-	0.4	2.0	2.0	2.0	0.9	2.0	2.0	2.0	1.7
-	3G3M1-A4004	0.75	2.0	2.0	2.0	1.5	2.0	2.0	2.0	2.7
3G3M1-A4007	-		2.0	2.0	2.0	1.6	2.0	2.0	2.0	3.1
-	3G3M1-A4007	1.1	2.0	2.0	2.0	2.1	2.0	2.0	2.0	3.9
3G3M1-A4015	-	1.5	2.0	2.0	2.0	3.0	2.0	2.0	2.0	5.9
-	3G3M1-A4015	2.2	2.0	2.0	2.0	4.2	2.0	2.0	2.0	7.3
3G3M1-A4022	-		2.0	2.0	2.0	4.4	2.0	2.0	2.0	8.2
-	3G3M1-A4022	3	2.0	2.0	2.0	5.8	2.0	2.0	2.0	11.3
3G3M1-A4030	-	3.7	2.0	2.0	2.0	7.3	2.0	2.0	2.0	13.0
-	3G3M1-A4030									
3G3M1-A4040	-									

Model		Maximum applicable motor capacity [kW]	Recommended wire size [mm <sup>2</sup> ]							
			Main power supply input (L1/R, L2/S, L3/T)							
When DC reactor (DCR) is used				Without DC reactor (DCR)						
HHD mode	HND mode		Allowable temperature (Note 1)			Current value [A]	Allowable temperature (Note 1)			Current value [A]
		60°C	75°C	90°C	60°C		75°C	90°C		
-	3G3M1-A4040	5.5	2.0	2.0	2.0	10.1	3.5	2.0	2.0	16.8
3G3M1-A4055	-		2.0	2.0	2.0	10.6	3.5	2.0	2.0	17.3
3G3M1-A4075	3G3M1-A4055	7.5	2.0	2.0	2.0	14.4	5.5	2.0	2.0	23.2
3G3M1-A4110	3G3M1-A4075	11	5.5	2.0	2.0	21.1	8.0	3.5	3.5	33.0
3G3M1-A4150	3G3M1-A4110	15	8.0	3.5	2.0	28.8	14.0	5.5	5.5	43.8
3G3M1-A4185	3G3M1-A4150	18.5	14.0	5.5	3.5	35.5	22.0	8.0	5.5	52.3
3G3M1-A4220	3G3M1-A4185	22	14.0	5.5	5.5	42.2	22.0	14.0	8.0	60.6
-	3G3M1-A4220	30	22.0	14.0	8.0	57.0	38.0*1	14.0	14.0	77.9

Model		Maximum applicable motor capacity [kW]	Recommended wire size [mm <sup>2</sup> ]							
			Inverter output (U, V, W)							
HHD mode				HND mode						
HHD mode	HND mode		Allowable temperature (Note 1)			Current value [A]	Allowable temperature (Note 1)			Current value [A]
		60°C	75°C	90°C	60°C		75°C	90°C		
3G3M1-A4004	-	0.4	2.0	2.0	2.0	1.8	-	-	-	-
-	3G3M1-A4004	0.75	-	-	-	-	2.0	2.0	2.0	2.1
3G3M1-A4007	-		2.0	2.0	2.0	3.4	-	-	-	-
-	3G3M1-A4007	1.1	-	-	-	-	2.0	2.0	2.0	4.1
3G3M1-A4015	-	1.5	2.0	2.0	2.0	4.8	-	-	-	-
-	3G3M1-A4015	2.2	-	-	-	-	2.0	2.0	2.0	5.5
3G3M1-A4022	-		2.0	2.0	2.0	5.5	-	-	-	-
-	3G3M1-A4022	3	-	-	-	-	2.0	2.0	2.0	6.9
3G3M1-A4030	-		-	-	-	-	-	-	-	-
-	3G3M1-A4030	3.7	2.0	2.0	2.0	9.2	-	-	-	-
3G3M1-A4040	-		-	-	-	-	-	-	-	-
-	3G3M1-A4040	5.5	-	-	-	-	2.0	2.0	2.0	11.1
3G3M1-A4055	-		2.0	2.0	2.0	14.8	-	-	-	-
3G3M1-A4075	3G3M1-A4055	7.5	3.5	2.0	2.0	18.0	3.5	2.0	2.0	17.5
3G3M1-A4110	3G3M1-A4075	11	5.5	2.0	2.0	24.0	5.5	2.0	2.0	23.0
3G3M1-A4150	3G3M1-A4110	15	8.0	3.5	2.0	31.0	8.0	5.5	3.5	31.0
3G3M1-A4185	3G3M1-A4150	18.5	14.0	5.5	3.5	39.0	14.0	5.5	3.5	38.0
3G3M1-A4220	3G3M1-A4185	22	14.0	8.0	5.5	45.0	14.0	8.0	5.5	45.0
-	3G3M1-A4220	30	-	-	-	-	22.0	14.0	8.0	60.0

Model		Maximum applicable motor capacity [kW]	Recommended wire size [mm <sup>2</sup> ]			
HHD mode	HND mode		DC reactor connection (P1, P(+))			
			Allowable temperature (Note 1)			Current value [A]
			60°C	75°C	90°C	
3G3M1-A4004	-	0.4	2.0	2.0	2.0	1.0
-	3G3M1-A4004	0.75	2.0	2.0	2.0	1.8
3G3M1-A4007	-		2.0	2.0	2.0	2.0
-	3G3M1-A4007	1.1	2.0	2.0	2.0	2.6
3G3M1-A4015	-	1.5	2.0	2.0	2.0	3.7
-	3G3M1-A4015	2.2	2.0	2.0	2.0	5.1
3G3M1-A4022	-		2.0	2.0	2.0	5.4
-	3G3M1-A4022	3	2.0	2.0	2.0	7.1
3G3M1-A4030	-					
-	3G3M1-A4030	3.7	2.0	2.0	2.0	8.9
3G3M1-A4040	-					
-	3G3M1-A4040	5.5	2.0	2.0	2.0	12.4
3G3M1-A4055	-		2.0	2.0	2.0	13.0
3G3M1-A4075	3G3M1-A4055	7.5	3.5	2.0	2.0	17.6
3G3M1-A4110	3G3M1-A4075	11	5.5	3.5	2.0	25.8
3G3M1-A4150	3G3M1-A4110	15	14.0	5.5	3.5	35.3
3G3M1-A4185	3G3M1-A4150	18.5	14.0	5.5	5.5	43.5
3G3M1-A4220	3G3M1-A4185	22	22.0	8.0	5.5	51.7
-	3G3M1-A4220	30	38.0*1	14.0	8.0	69.8

Model		Maximum applicable motor capacity [kW]	Recommended wire size [mm <sup>2</sup> ]							
HHD mode	HND mode		Brake resistance connection (P(+), DB)							
			HHD mode				HND mode			
			Allowable temperature (Note 1)			Current value [A]	Allowable temperature (Note 1)			Current value [A]
60°C	75°C	90°C	60°C	75°C	90°C					
3G3M1-A4004	-	0.4	2.0	2.0	2.0	0.4	-	-	-	-
-	3G3M1-A4004	0.75	-	-	-	-	2.0	2.0	2.0	0.4
3G3M1-A4007	-		2.0	2.0	2.0	0.5	-	-	-	-
-	3G3M1-A4007	1.1	-	-	-	-	2.0	2.0	2.0	0.6
3G3M1-A4015	-	1.5	2.0	2.0	2.0	0.7	-	-	-	-
-	3G3M1-A4015	2.2	-	-	-	-	2.0	2.0	2.0	0.8
3G3M1-A4022	-		2.0	2.0	2.0	0.9	-	-	-	-
-	3G3M1-A4022	3	-	-	-	-	2.0	2.0	2.0	0.9
3G3M1-A4030	-									
-	3G3M1-A4030	3.7	2.0	2.0	2.0	1.2	-	-	-	-
3G3M1-A4040	-									

Model		Maximum applicable motor capacity [kW]	Recommended wire size [mm <sup>2</sup> ]							
			Brake resistance connection (P(+), DB)							
HHD mode	HND mode		HHD mode				HND mode			
			Allowable temperature (Note 1)			Current value [A]	Allowable temperature (Note 1)			Current value [A]
60°C	75°C	90°C	60°C	75°C	90°C					
-	3G3M1-A4040	5.5	-	-	-	-	2.0	2.0	2.0	1.3
3G3M1-A4055	-		2.0	2.0	2.0	1.9	-	-	-	-
3G3M1-A4075	3G3M1-A4055	7.5	2.0	2.0	2.0	2.5	2.0	2.0	2.0	1.9
3G3M1-A4110	3G3M1-A4075	11	2.0	2.0	2.0	3.8	2.0	2.0	2.0	2.7
3G3M1-A4150	3G3M1-A4110	15	2.0	2.0	2.0	4.7	2.0	2.0	2.0	3.8
3G3M1-A4185	3G3M1-A4150	18.5	2.0	2.0	2.0	6.5	2.0	2.0	2.0	4.5
3G3M1-A4220	3G3M1-A4185	22	2.0	2.0	2.0	7.1	2.0	2.0	2.0	6.2
-	3G3M1-A4220	30	-	-	-	-	2.0	2.0	2.0	7.2

Model		Maximum applicable motor capacity [kW]	Recommended wire size [mm <sup>2</sup> ]		
			Inverter ground (G)		
HHD mode	HND mode		Allowable temperature (Note 1)		
			60°C	75°C	90°C
3G3M1-A4004	-	0.4	2.0	2.0	2.0
-	3G3M1-A4004	0.75	2.0	2.0	2.0
3G3M1-A4007	-		2.0	2.0	2.0
-	3G3M1-A4007	1.1	2.0	2.0	2.0
3G3M1-A4015	-	1.5	2.0	2.0	2.0
-	3G3M1-A4015	2.2	2.0	2.0	2.0
3G3M1-A4022	-		2.0	2.0	2.0
-	3G3M1-A4022	3	2.0	2.0	2.0
3G3M1-A4030	-				
-	3G3M1-A4030	3.7	2.0	2.0	2.0
3G3M1-A4040	-				
-	3G3M1-A4040	5.5	2.0	2.0	2.0
3G3M1-A4055	-		2.0	2.0	2.0
3G3M1-A4075	3G3M1-A4055	7.5	2.0	2.0	2.0
3G3M1-A4110	3G3M1-A4075	11	3.5	3.5	3.5
3G3M1-A4150	3G3M1-A4110	15	5.5	5.5	5.5
3G3M1-A4185	3G3M1-A4150	18.5	5.5	5.5	5.5
3G3M1-A4220	3G3M1-A4185	22	5.5	5.5	5.5
-	3G3M1-A4220	30	8.0	8.0	8.0

● Single-phase 200-V class (Panel internal temperature 50°C or less)

Model		Maximum applicable motor capacity [kW]	Recommended wire size [mm <sup>2</sup> ]							
			Main power supply input (L1/R, L2/S, L3/T)							
HHD mode			HND mode		When DC reactor (DCR) is used			Without DC reactor (DCR)		
					Allowable temperature (Note 1)			Current value [A]	Allowable temperature (Note 1)	
60°C	75°C	90°C	60°C	75°C	90°C					
3G3M1-AB001	-	0.1	2.0	2.0	2.0	1.1	2.0	2.0	2.0	1.8
-	3G3M1-AB001	0.2	2.0	2.0	2.0	2.7	2.0	2.0	2.0	2.0
3G3M1-AB002	-		2.0	2.0	2.0	2.0	2.0	2.0	2.0	3.3
-	3G3M1-AB002	0.4	2.0	2.0	2.0	3.7	2.0	2.0	2.0	3.6
3G3M1-AB004	-		2.0	2.0	2.0	3.5	2.0	2.0	2.0	5.4
-	3G3M1-AB004	0.55	2.0	2.0	2.0	4.6	2.0	2.0	2.0	7.3
3G3M1-AB007	-	0.75	2.0	2.0	2.0	6.4	2.0	2.0	2.0	9.7
-	3G3M1-AB007	1.1	2.0	2.0	2.0	9.4	2.0	2.0	2.0	13.8
3G3M1-AB015	-	1.5	2.0	2.0	2.0	11.6	3.5	2.0	2.0	16.4
-	3G3M1-AB015	2.2	3.5	2.0	2.0	17.9	3.5	2.0	2.0	20.2
3G3M1-AB022	-		3.5	2.0	2.0	17.5	5.5	2.0	2.0	22.0
-	3G3M1-AB022	3	5.5	3.5	2.0	25.0	5.5	2.0	2.0	24.0
3G3M1-AB037	-	3.7	8.0	3.5	3.5	31.8	14.0	8.0	5.5	45.4

Model		Maximum applicable motor capacity [kW]	Recommended wire size [mm <sup>2</sup> ]							
			Inverter output (U, V, W)							
HHD mode			HND mode		HHD mode			HND mode		
					Allowable temperature (Note 1)			Current value [A]	Allowable temperature (Note 1)	
60°C	75°C	90°C	60°C	75°C	90°C					
3G3M1-AB001	-	0.1	2.0	2.0	2.0	1.0	-	-	-	-
-	3G3M1-AB001	0.2	-	-	-	-	2.0	2.0	2.0	1.2
3G3M1-AB002	-		2.0	2.0	2.0	1.6	-	-	-	-
-	3G3M1-AB002	0.4	-	-	-	-	2.0	2.0	2.0	1.9
3G3M1-AB004	-		2.0	2.0	2.0	3.0	-	-	-	-
-	3G3M1-AB004	0.55	-	-	-	-	2.0	2.0	2.0	3.5
3G3M1-AB007	-	0.75	2.0	2.0	2.0	5.0	-	-	-	-
-	3G3M1-AB007	1.1	-	-	-	-	2.0	2.0	2.0	6.0
3G3M1-AB015	-	1.5	2.0	2.0	2.0	8.0	-	-	-	-
-	3G3M1-AB015	2.2	-	-	-	-	2.0	2.0	2.0	9.6
3G3M1-AB022	-		2.0	2.0	2.0	11.0	-	-	-	-
-	3G3M1-AB022	3	-	-	-	-	2.0	2.0	2.0	12.0
3G3M1-AB037	-	3.7	3.5	2.0	2.0	17.5	-	-	-	-

Model		Maximum applicable motor capacity [kW]	Recommended wire size [mm <sup>2</sup> ]			
			DC reactor connection (P1, P(+))			
HHD mode	HND mode		Allowable temperature (Note 1)			Current value [A]
		60°C	75°C	90°C		
3G3M1-AB001	-	0.1	2.0	2.0	2.0	1.3
-	3G3M1-AB001	0.2	2.0	2.0	2.0	2.7
3G3M1-AB002	-		2.0	2.0	2.0	2.4
-	3G3M1-AB002	0.4	2.0	2.0	2.0	4.5
3G3M1-AB004	-		2.0	2.0	2.0	4.3
-	3G3M1-AB004	0.55	2.0	2.0	2.0	5.6
3G3M1-AB007	-		2.0	2.0	2.0	7.8
-	3G3M1-AB007	1.1	2.0	2.0	2.0	11.5
3G3M1-AB015	-		2.0	2.0	2.0	14.2
-	3G3M1-AB015	2.2	5.5	2.0	2.0	21.9
3G3M1-AB022	-		3.5	2.0	2.0	21
-	3G3M1-AB022	3	8.0	3.5	2.0	30.6
3G3M1-AB037	-		3.7	14.0	5.5	3.5

Model		Maximum applicable motor capacity [kW]	Recommended wire size [mm <sup>2</sup> ]							
			Brake resistance connection (P(+), DB)							
HHD mode	HND mode		HHD mode				HND mode			
		Allowable temperature (Note 1)			Current value [A]	Allowable temperature (Note 1)			Current value [A]	
60°C	75°C	90°C	60°C	75°C		90°C				
3G3M1-AB001	-	0.1	2.0	2.0	2.0	0.3	-	-	-	-
-	3G3M1-AB001	0.2	-	-	-	-	2.0	2.0	2.0	0.3
3G3M1-AB002	-		2.0	2.0	2.0	0.4	-	-	-	-
-	3G3M1-AB002	0.4	-	-	-	-	2.0	2.0	2.0	0.4
3G3M1-AB004	-		2.0	2.0	2.0	0.5	-	-	-	-
-	3G3M1-AB004	0.55	-	-	-	-	2.0	2.0	2.0	0.6
3G3M1-AB007	-		2.0	2.0	2.0	0.7	-	-	-	-
-	3G3M1-AB007	1.1	-	-	-	-	2.0	2.0	2.0	1.1
3G3M1-AB015	-		2.0	2.0	2.0	1.4	-	-	-	-
-	3G3M1-AB015	2.2	-	-	-	-	2.0	2.0	2.0	1.5
3G3M1-AB022	-		2.0	2.0	2.0	1.7	-	-	-	-
-	3G3M1-AB022	3	-	-	-	-	2.0	2.0	2.0	1.9
3G3M1-AB037	-		3.7	2.0	2.0	2.0	2.4	-	-	-

Model		Maximum applicable motor capacity [kW]	Recommended wire size [mm <sup>2</sup> ]		
HHD mode	HND mode		Inverter ground (G)		
			Allowable temperature (Note 1)		
			60°C	75°C	90°C
3G3M1-AB001	-	0.1	2.0	2.0	2.0
-	3G3M1-AB001	0.2	2.0	2.0	2.0
3G3M1-AB002	-		2.0	2.0	2.0
-	3G3M1-AB002	0.4	2.0	2.0	2.0
3G3M1-AB004	-		2.0	2.0	2.0
-	3G3M1-AB004	0.55	2.0	2.0	2.0
3G3M1-AB007	-	0.75	2.0	2.0	2.0
-	3G3M1-AB007	1.1	2.0	2.0	2.0
3G3M1-AB015	-	1.5	2.0	2.0	2.0
-	3G3M1-AB015	2.2	2.0	2.0	2.0
3G3M1-AB022	-		2.0	2.0	2.0
-	3G3M1-AB022	3	2.0	2.0	2.0
3G3M1-AB037	-	3.7	3.5	3.5	3.5

● Three-phase 200-V class (Panel internal temperature 40°C or less)

Model		Maximum applicable motor capacity [kW]	Recommended wire size [mm <sup>2</sup> ]							
HHD mode	HND mode		Main power supply input (L1/R, L2/S, L3/T)							
			When DC reactor (DCR) is used				Without DC reactor			
			Allowable temperature (Note 1)			Current value [A]	Allowable temperature (Note 1)			Current value [A]
60°C	75°C	90°C	60°C	75°C	90°C					
3G3M1-A2001	-	0.1	2.0	2.0	2.0	0.6	2.0	2.0	2.0	1.1
3G3M1-A2002	3G3M1-A2001	0.2	2.0	2.0	2.0	0.9	2.0	2.0	2.0	1.8
-	3G3M1-A2002	0.4	2.0	2.0	2.0	1.6	2.0	2.0	2.0	2.6
3G3M1-A2004	-		2.0	2.0	2.0	1.6	2.0	2.0	2.0	3.1
-	3G3M1-A2004	0.75	2.0	2.0	2.0	3.0	2.0	2.0	2.0	4.9
3G3M1-A2007	-		2.0	2.0	2.0	3.0	2.0	2.0	2.0	5.3
-	3G3M1-A2007	1.1	2.0	2.0	2.0	4.3	2.0	2.0	2.0	6.7
3G3M1-A2015	-	1.5	2.0	2.0	2.0	5.7	2.0	2.0	2.0	9.5
-	3G3M1-A2015	2.2	2.0	2.0	2.0	8.3	2.0	2.0	2.0	12.8
3G3M1-A2022	-		2.0	2.0	2.0	8.3	2.0	2.0	2.0	13.2
-	3G3M1-A2022	3	2.0	2.0	2.0	11.7	2.0	2.0	2.0	17.9
3G3M1-A2037	-	3.7	2.0	2.0	2.0	14.0	3.5	2.0	2.0	22.2
-	3G3M1-A2037	5.5	2.0	2.0	2.0	19.9	3.5	2.0	2.0	28.5
3G3M1-A2055	-		2.0	2.0	2.0	21.1	5.5	3.5	2.0	31.5
3G3M1-A2075	3G3M1-A2055	7.5	3.5	2.0	2.0	28.8	8.0	5.5	3.5	42.7
3G3M1-A2110	3G3M1-A2075	11	8.0	5.5	3.5	42.2	14.0	8.0	5.5	60.7
3G3M1-A2150	3G3M1-A2110	15	14.0	8.0	5.5	57.6	22.0	14.0	14.0	80.0



Model		Maximum applicable motor capacity [kW]	Recommended wire size [mm <sup>2</sup> ]							
			Main power supply input (L1/R, L2/S, L3/T)							
When DC reactor (DCR) is used				Without DC reactor						
HHD mode	HND mode		Allowable temperature (Note 1)			Current value [A]	Allowable temperature (Note 1)			Current value [A]
		60°C	75°C	90°C	60°C		75°C	90°C		
3G3M1-A2185	3G3M1-A2150	18.5	14.0	14.0	8.0	71.0	38.0*1	22.0	14.0	97.0
-	3G3M1-A2185	22	22.0	14.0	14.0	84.4	38.0*1	22.0	14.0	112.0

Model		Maximum applicable motor capacity [kW]	Recommended wire size [mm <sup>2</sup> ]							
			Inverter output (U, V, W)							
HHD mode				HND mode						
HHD mode	HND mode		Allowable temperature (Note 1)			Current value [A]	Allowable temperature (Note 1)			Current value [A]
		60°C	75°C	90°C	60°C		75°C	90°C		
3G3M1-A2001	-	0.1	2.0	2.0	2.0	1.0	-	-	-	-
3G3M1-A2002	3G3M1-A2001	0.2	2.0	2.0	2.0	1.6	2.0	2.0	2.0	1.3
-	3G3M1-A2002	0.4	-	-	-	-	2.0	2.0	2.0	2.0
3G3M1-A2004	-		2.0	2.0	2.0	3.0	-	-	-	-
-	3G3M1-A2004	0.75	-	-	-	-	2.0	2.0	2.0	3.5
3G3M1-A2007	-		2.0	2.0	2.0	5.0	-	-	-	-
-	3G3M1-A2007	1.1	-	-	-	-	2.0	2.0	2.0	6.0
3G3M1-A2015	-		1.5	2.0	2.0	2.0	8.0	-	-	-
-	3G3M1-A2015	2.2	-	-	-	-	2.0	2.0	2.0	9.6
3G3M1-A2022	-		2.0	2.0	2.0	11.0	-	-	-	-
-	3G3M1-A2022	3	-	-	-	-	2.0	2.0	2.0	12.0
3G3M1-A2037	-		3.7	2.0	2.0	2.0	17.5	-	-	-
-	3G3M1-A2037	5.5	-	-	-	-	2.0	2.0	2.0	19.6
3G3M1-A2055	-		3.5	2.0	2.0	25.0	-	-	-	-
3G3M1-A2075	3G3M1-A2055	7.5	5.5	3.5	2.0	33.0	3.5	3.5	2.0	30.0
3G3M1-A2110	3G3M1-A2075	11	8.0	5.5	3.5	47.0	5.5	5.5	3.5	40.0
3G3M1-A2150	3G3M1-A2110	15	14.0	8.0	5.5	60.0	14.0	8.0	5.5	56.0
3G3M1-A2185	3G3M1-A2150	18.5	22.0	14.0	8.0	76.0	14.0	14.0	8.0	69.0
-	3G3M1-A2185	22	22.0	14.0	14.0	90.0	22.0	14.0	14.0	88.0

Model		Maximum applicable motor capacity [kW]	Recommended wire size [mm <sup>2</sup> ]			
			DC reactor connection (P1, P(+))			
Allowable temperature (Note 1)			Current value [A]			
HHD mode	HND mode			60°C	75°C	90°C
3G3M1-A2001	-	0.1	2.0	2.0	2.0	0.7

Model		Maximum applicable motor capacity [kW]	Recommended wire size [mm <sup>2</sup> ]			
HHD mode	HND mode		DC reactor connection (P1, P(+))			
			Allowable temperature (Note 1)			Current value [A]
			60°C	75°C	90°C	
3G3M1-A2002	3G3M1-A2001	0.2	2.0	2.0	2.0	1.1
-	3G3M1-A2002	0.4	2.0	2.0	2.0	2.0
3G3M1-A2004	-		2.0	2.0	2.0	2.0
-	3G3M1-A2004	0.75	2.0	2.0	2.0	3.7
3G3M1-A2007	-		2.0	2.0	2.0	3.7
-	3G3M1-A2007	1.1	2.0	2.0	2.0	5.3
3G3M1-A2015	-	1.5	2.0	2.0	2.0	7.0
-	3G3M1-A2015	2.2	2.0	2.0	2.0	10.2
3G3M1-A2022	-		2.0	2.0	2.0	10.2
-	3G3M1-A2022	3	2.0	2.0	2.0	14.3
3G3M1-A2037	-	3.7	2.0	2.0	2.0	17.1
-	3G3M1-A2037	5.5	3.5	2.0	2.0	24.4
3G3M1-A2055	-		3.5	2.0	2.0	25.8
3G3M1-A2075	3G3M1-A2055	7.5	5.5	3.5	3.5	35.3
3G3M1-A2110	3G3M1-A2075	11	14.0	5.5	5.5	51.7
3G3M1-A2150	3G3M1-A2110	15	14.0	14.0	8.0	70.5
3G3M1-A2185	3G3M1-A2150	18.5	22.0	14.0	14.0	87.0
-	3G3M1-A2185	22	38.0*1	22.0	14.0	103.4

Model		Maximum applicable motor capacity [kW]	Recommended wire size [mm <sup>2</sup> ]							
HHD mode	HND mode		Brake resistance connection (P(+), DB)							
			HHD mode				HND mode			
			Allowable temperature (Note 1)			Current value [A]	Allowable temperature (Note 1)			Current value [A]
60°C	75°C	90°C	60°C	75°C	90°C					
3G3M1-A2001	-	0.1	2.0	2.0	2.0	0.3	-	-	-	-
3G3M1-A2002	3G3M1-A2001	0.2	2.0	2.0	2.0	0.4	2.0	2.0	2.0	0.3
-	3G3M1-A2002	0.4	-	-	-	-	2.0	2.0	2.0	0.4
3G3M1-A2004	-		2.0	2.0	2.0	0.5	-	-	-	-
-	3G3M1-A2004	0.75	-	-	-	-	2.0	2.0	2.0	0.6
3G3M1-A2007	-		2.0	2.0	2.0	0.7	-	-	-	-
-	3G3M1-A2007	1.1	-	-	-	-	2.0	2.0	2.0	0.8
3G3M1-A2015	-	1.5	2.0	2.0	2.0	1.4	-	-	-	-
-	3G3M1-A2015	2.2	-	-	-	-	2.0	2.0	2.0	1.5
3G3M1-A2022	-		2.0	2.0	2.0	1.7	-	-	-	-
-	3G3M1-A2022	3	-	-	-	-	2.0	2.0	2.0	1.7
3G3M1-A2037	-	3.7	2.0	2.0	2.0	2.4	-	-	-	-

Model		Maximum applicable motor capacity [kW]	Recommended wire size [mm <sup>2</sup> ]							
			Brake resistance connection (P(+), DB)							
HHD mode	HND mode		HHD mode				HND mode			
			Allowable temperature (Note 1)			Current value [A]	Allowable temperature (Note 1)			Current value [A]
60°C	75°C	90°C	60°C	75°C	90°C					
-	3G3M1-A2037	5.5	-	-	-	-	2.0	2.0	2.0	2.5
3G3M1-A2055	-		2.0	2.0	2.0	3.8	-	-	-	-
3G3M1-A2075	3G3M1-A2055	7.5	2.0	2.0	2.0	5.0	2.0	2.0	2.0	3.8
3G3M1-A2110	3G3M1-A2075	11	2.0	2.0	2.0	7.5	2.0	2.0	2.0	5.3
3G3M1-A2150	3G3M1-A2110	15	2.0	2.0	2.0	9.4	2.0	2.0	2.0	7.5
3G3M1-A2185	3G3M1-A2150	18.5	2.0	2.0	2.0	12.7	2.0	2.0	2.0	9.0
-	3G3M1-A2185	22	2.0	2.0	2.0	13.8	2.0	2.0	2.0	12.0

Model		Maximum applicable motor capacity [kW]	Recommended wire size [mm <sup>2</sup> ]		
			Inverter ground (G)		
HHD mode	HND mode		Allowable temperature (Note 1)		
			60°C	75°C	90°C
3G3M1-A2001	-	0.1	2.0	2.0	2.0
3G3M1-A2002	3G3M1-A2001	0.2	2.0	2.0	2.0
-	3G3M1-A2002	0.4	2.0	2.0	2.0
3G3M1-A2004	-		2.0	2.0	2.0
-	3G3M1-A2004	0.75	2.0	2.0	2.0
3G3M1-A2007	-		2.0	2.0	2.0
-	3G3M1-A2007	1.1	2.0	2.0	2.0
3G3M1-A2015	-	1.5	2.0	2.0	2.0
-	3G3M1-A2015	2.2	2.0	2.0	2.0
3G3M1-A2022	-		2.0	2.0	2.0
-	3G3M1-A2022	3	2.0	2.0	2.0
3G3M1-A2037	-	3.7	2.0	2.0	2.0
-	3G3M1-A2037	5.5	3.5	3.5	3.5
3G3M1-A2055	-		3.5	3.5	3.5
3G3M1-A2075	3G3M1-A2055	7.5	5.5	5.5	5.5
3G3M1-A2110	3G3M1-A2075	11	5.5	5.5	5.5
3G3M1-A2150	3G3M1-A2110	15	5.5	5.5	5.5
3G3M1-A2220	3G3M1-A2150	18.5	8.0	8.0	8.0
-	3G3M1-A2185	22	8.0	8.0	8.0

● Three-phase 400-V class (Panel internal temperature 40°C or less)

Model		Maximum applicable motor capacity [kW]	Recommended wire size [mm <sup>2</sup> ]							
			Main power supply input (L1/R, L2/S, L3/T)							
HHD mode			HND mode		When DC reactor (DCR) is used			Without DC reactor (DCR)		
					Allowable temperature (Note 1)			Current value [A]	Allowable temperature (Note 1)	
60°C	75°C	90°C	60°C	75°C	90°C					
3G3M1-A4004	-	0.4	2.0	2.0	2.0	0.9	2.0	2.0	2.0	1.7
-	3G3M1-A4004	0.75	2.0	2.0	2.0	1.5	2.0	2.0	2.0	2.7
3G3M1-A4007	-		2.0	2.0	2.0	1.6	2.0	2.0	2.0	3.1
-	3G3M1-A4007	1.1	2.0	2.0	2.0	2.1	2.0	2.0	2.0	3.9
3G3M1-A4015	-	1.5	2.0	2.0	2.0	3.0	2.0	2.0	2.0	5.9
-	3G3M1-A4015	2.2	2.0	2.0	2.0	4.2	2.0	2.0	2.0	7.3
3G3M1-A4022	-		2.0	2.0	2.0	4.4	2.0	2.0	2.0	8.2
-	3G3M1-A4022	3	2.0	2.0	2.0	5.8	2.0	2.0	2.0	11.3
3G3M1-A4030	-									
-	3G3M1-A4030	3.7	2.0	2.0	2.0	7.3	2.0	2.0	2.0	13.0
3G3M1-A4040	-									
-	3G3M1-A4040	5.5	2.0	2.0	2.0	10.1	2.0	2.0	2.0	16.8
3G3M1-A4055	-		2.0	2.0	2.0	10.6	2.0	2.0	2.0	17.3
3G3M1-A4075	3G3M1-A4055	7.5	2.0	2.0	2.0	14.4	3.5	2.0	2.0	23.2
3G3M1-A4110	3G3M1-A4075	11	2.0	2.0	2.0	21.1	5.5	3.5	2.0	33.0
3G3M1-A4150	3G3M1-A4110	15	3.5	2.0	2.0	28.8	8.0	5.5	3.5	43.8
3G3M1-A4185	3G3M1-A4150	18.5	5.5	3.5	3.5	35.5	14.0	8.0	5.5	52.3
3G3M1-A4220	3G3M1-A4185	22	8.0	5.5	3.5	42.2	14.0	8.0	5.5	60.6
-	3G3M1-A4220	30	14.0	8.0	5.5	57.0	22.0	14.0	8.0	77.9

Model		Maximum applicable motor capacity [kW]	Recommended wire size [mm <sup>2</sup> ]							
			Inverter output (U, V, W)							
HHD mode			HND mode		HHD mode			HND mode		
					Allowable temperature (Note 1)			Current value [A]	Allowable temperature (Note 1)	
60°C	75°C	90°C	60°C	75°C	90°C					
3G3M1-A4004	-	0.4	2.0	2.0	2.0	1.8	-	-	-	-
-	3G3M1-A4004	0.75	-	-	-	-	2.0	2.0	2.0	2.1
3G3M1-A4007	-		2.0	2.0	2.0	3.4	-	-	-	-
-	3G3M1-A4007	1.1	-	-	-	-	2.0	2.0	2.0	4.1
3G3M1-A4015	-	1.5	2.0	2.0	2.0	4.8	-	-	-	-
-	3G3M1-A4015	2.2	-	-	-	-	2.0	2.0	2.0	5.5
3G3M1-A4022	-		2.0	2.0	2.0	5.5	-	-	-	-
-	3G3M1-A4022	3	-	-	-	-	2.0	2.0	2.0	6.9
3G3M1-A4030	-									
-	3G3M1-A4030	3.7	2.0	2.0	2.0	9.2	-	-	-	-
3G3M1-A4040	-									

Model		Maximum applicable motor capacity [kW]	Recommended wire size [mm <sup>2</sup> ]							
			Inverter output (U, V, W)							
HHD mode	HND mode		HHD mode				HND mode			
			Allowable temperature (Note 1)			Current value [A]	Allowable temperature (Note 1)			Current value [A]
60°C	75°C	90°C	60°C	75°C	90°C					
-	3G3M1-A4040	5.5	-	-	-	-	2.0	2.0	2.0	11.1
3G3M1-A4055	-		2.0	2.0	2.0	14.8	-	-	-	-
3G3M1-A4075	3G3M1-A4055	7.5	2.0	2.0	2.0	18.0	2.0	2.0	2.0	17.5
3G3M1-A4110	3G3M1-A4075	11	3.5	2.0	2.0	24.0	3.5	2.0	2.0	23.0
3G3M1-A4150	3G3M1-A4110	15	5.5	3.5	2.0	31.0	5.5	3.5	2.0	31.0
3G3M1-A4185	3G3M1-A4150	18.5	5.5	3.5	3.5	39.0	5.5	3.5	3.5	38.0
3G3M1-A4220	3G3M1-A4185	22	8.0	5.5	3.5	45.0	8.0	5.5	3.5	45.0
-	3G3M1-A4220	30	-	-	-	-	14.0	8.0	5.5	60.0

Model		Maximum applicable motor capacity [kW]	Recommended wire size [mm <sup>2</sup> ]							
			Main power supply input (L1/R, L2/S, L3/T)							
HD mode	ND mode		When DC reactor (DCR) is used				Without DC reactor (DCR)			
			Allowable temperature (Note 1)			Current value [A]	Allowable temperature (Note 1)			Current value [A]
60°C	75°C	90°C	60°C	75°C	90°C					
3G3M1-A4004	3G3M1-A4004	0.75	2.0	2.0	2.0	1.5	2.0	2.0	2.0	2.7
3G3M1-A4007	-	1.1	2.0	2.0	2.0	2.1	2.0	2.0	2.0	3.9
-	3G3M1-A4007	1.5	2.0	2.0	2.0	2.9	2.0	2.0	2.0	4.8
3G3M1-A4015	3G3M1-A4015	2.2	2.0	2.0	2.0	4.2	2.0	2.0	2.0	7.3
3G3M1-A4022	3G3M1-A4022	3	2.0	2.0	2.0	5.8	2.0	2.0	2.0	11.3
3G3M1-A4030	3G3M1-A4030	5.5	2.0	2.0	2.0	10.1	2.0	2.0	2.0	16.8
3G3M1-A4040	3G3M1-A4040									
3G3M1-A4055	-	7.5	2.0	2.0	2.0	14.4	3.5	2.0	2.0	23.2
3G3M1-A4075	3G3M1-A4055	11	2.0	2.0	2.0	21.1	5.5	3.5	2.0	33.0
3G3M1-A4110	3G3M1-A4075	15	3.5	2.0	2.0	28.8	8.0	5.5	3.5	43.8
3G3M1-A4150	3G3M1-A4110	18.5	5.5	3.5	3.5	35.5	14.0	8.0	5.5	52.3
3G3M1-A4185	3G3M1-A4150	22	8.0	5.5	3.5	42.2	14.0	8.0	5.5	60.6
3G3M1-A4220	3G3M1-A4185	30	14.0	8.0	5.5	57.0	22.0	14.0	8.0	77.9
-	3G3M1-A4220	37	14.0	14.0	8.0	68.5	38*1	14.0	14.0	94.3

Model		Maximum applicable motor capacity [kW]	Recommended wire size [mm <sup>2</sup> ]							
			Inverter output (U, V, W)							
HD mode	ND mode		HD mode				ND mode			
			Allowable temperature (Note 1)			Current value [A]	Allowable temperature (Note 1)			Current value [A]
		60°C	75°C	90°C	60°C		75°C	90°C		
3G3M1-A4004	3G3M1-A4004	0.75	2.0	2.0	2.0	1.8	2.0	2.0	2.0	2.1
3G3M1-A4007	-	1.1	2.0	2.0	2.0	3.4	-	-	-	-
-	3G3M1-A4007	1.5	-	-	-	-	2.0	2.0	2.0	4.1
3G3M1-A4015	3G3M1-A4015	2.2	2.0	2.0	2.0	5.0	2.0	2.0	2.0	5.5
3G3M1-A4022	3G3M1-A4022	3	2.0	2.0	2.0	6.3	2.0	2.0	2.0	6.9
3G3M1-A4030	3G3M1-A4030	5.5	2.0	2.0	2.0	11.1	2.0	2.0	2.0	12.0
3G3M1-A4040	3G3M1-A4040									
3G3M1-A4055	-	7.5	2.0	2.0	2.0	17.5	-	-	-	-
3G3M1-A4075	3G3M1-A4055	11	3.5	2.0	2.0	23.0	2.0	2.0	2.0	21.5
3G3M1-A4110	3G3M1-A4075	15	5.5	3.5	2.0	31.0	3.5	2.0	2.0	28.5
3G3M1-A4150	3G3M1-A4110	18.5	5.5	3.5	3.5	38.0	5.5	3.5	3.5	37.0
3G3M1-A4185	3G3M1-A4150	22	8.0	5.5	3.5	45.0	8.0	5.5	3.5	44.0
3G3M1-A4220	3G3M1-A4185	30	14.0	8.0	5.5	60.0	14.0	8.0	5.5	59.0
-	3G3M1-A4220	37	-	-	-	-	22.0	14.0	8.0	72.0

Model		Maximum applicable motor capacity [kW]	Recommended wire size [mm <sup>2</sup> ]			
			DC reactor connection (P1, P(+))			
HHD mode	HND mode		Allowable temperature (Note 1)			Current value [A]
			60°C	75°C	90°C	
		3G3M1-A4004	-	0.4	2.0	2.0
-	3G3M1-A4004	0.75	2.0	2.0	2.0	1.8
3G3M1-A4007	-		2.0	2.0	2.0	2.0
-	3G3M1-A4007		1.1	2.0	2.0	2.0
3G3M1-A4015	-	1.5	2.0	2.0	2.0	3.7
-	3G3M1-A4015		2.2	2.0	2.0	2.0
3G3M1-A4022	-	3	2.0	2.0	2.0	5.4
-	3G3M1-A4022		2.0	2.0	2.0	7.1
3G3M1-A4030	-		3.7	2.0	2.0	2.0
-	3G3M1-A4030	5.5	2.0	2.0	2.0	12.4
3G3M1-A4040	-					
-	3G3M1-A4040	7.5	2.0	2.0	2.0	13.0
3G3M1-A4055	-	7.5	2.0	2.0	2.0	17.6
3G3M1-A4075	3G3M1-A4055					
3G3M1-A4110	3G3M1-A4075	11	3.5	2.0	2.0	25.8
3G3M1-A4150	3G3M1-A4110	15	5.5	3.5	3.5	35.3
3G3M1-A4185	3G3M1-A4150	18.5	8.0	5.5	3.5	43.5

Model		Maximum applicable motor capacity [kW]	Recommended wire size [mm <sup>2</sup> ]			
HHD mode	HND mode		DC reactor connection (P1, P(+))			
			Allowable temperature (Note 1)			Current value [A]
			60°C	75°C	90°C	
3G3M1-A4220	3G3M1-A4185	22	14.0	5.5	5.5	51.7
-	3G3M1-A4220	30	14.0	14.0	8.0	69.8

Model		Maximum applicable motor capacity [kW]	Recommended wire size [mm <sup>2</sup> ]							
HHD mode	HND mode		Brake resistance connection (P(+), DB)							
			HHD mode				HND mode			
			Allowable temperature (Note 1)			Current value [A]	Allowable temperature (Note 1)			Current value [A]
60°C	75°C	90°C	60°C	75°C	90°C					
3G3M1-A4004	-	0.4	2.0	2.0	2.0	0.4	-	-	-	-
-	3G3M1-A4004	0.75	-	-	-	-	2.0	2.0	2.0	0.4
3G3M1-A4007	-		2.0	2.0	2.0	0.5	-	-	-	-
-	3G3M1-A4007	1.1	-	-	-	-	2.0	2.0	2.0	0.6
3G3M1-A4015	-	1.5	2.0	2.0	2.0	0.7	-	-	-	-
-	3G3M1-A4015	2.2	-	-	-	-	2.0	2.0	2.0	0.8
3G3M1-A4022	-		2.0	2.0	2.0	0.9	-	-	-	-
-	3G3M1-A4022	3	-	-	-	-	2.0	2.0	2.0	0.9
3G3M1-A4030	-									
-	3G3M1-A4030	3.7	2.0	2.0	2.0	1.2	-	-	-	-
3G3M1-A4040	-									
-	3G3M1-A4040	5.5	-	-	-	-	2.0	2.0	2.0	1.3
3G3M1-A4055	-		2.0	2.0	2.0	1.9	-	-	-	-
3G3M1-A4075	3G3M1-A4055	7.5	2.0	2.0	2.0	2.5	2.0	2.0	2.0	1.9
3G3M1-A4110	3G3M1-A4075	11	2.0	2.0	2.0	3.8	2.0	2.0	2.0	2.7
3G3M1-A4150	3G3M1-A4110	15	2.0	2.0	2.0	4.7	2.0	2.0	2.0	3.8
3G3M1-A4185	3G3M1-A4150	18.5	2.0	2.0	2.0	6.5	2.0	2.0	2.0	4.5
3G3M1-A4220	3G3M1-A4185	22	2.0	2.0	2.0	7.1	2.0	2.0	2.0	6.2
-	3G3M1-A4220	30	-	-	-	-	2.0	2.0	2.0	7.2

Model		Maximum applicable motor capacity [kW]	Recommended wire size [mm <sup>2</sup> ]		
HHD mode	HND mode		Inverter ground (G)		
			Allowable temperature (Note 1)		
			60°C	75°C	90°C
3G3M1-A4004	-	0.4	2.0	2.0	2.0

Model		Maximum applicable motor capacity [kW]	Recommended wire size [mm <sup>2</sup> ]		
HHD mode	HND mode		Inverter ground (G)		
			Allowable temperature (Note 1)		
			60°C	75°C	90°C
-	3G3M1-A4004	0.75	2.0	2.0	2.0
3G3M1-A4007	-		2.0	2.0	2.0
-	3G3M1-A4007	1.1	2.0	2.0	2.0
3G3M1-A4015	-	1.5	2.0	2.0	2.0
-	3G3M1-A4015	2.2	2.0	2.0	2.0
3G3M1-A4022	-		2.0	2.0	2.0
-	3G3M1-A4022	3	2.0	2.0	2.0
3G3M1-A4030	-				
-	3G3M1-A4030	3.7	2.0	2.0	2.0
3G3M1-A4040	-				
-	3G3M1-A4040	5.5	2.0	2.0	2.0
3G3M1-A4055	-		2.0	2.0	2.0
3G3M1-A4075	3G3M1-A4055	7.5	2.0	2.0	2.0
3G3M1-A4110	3G3M1-A4075	11	3.5	3.5	3.5
3G3M1-A4150	3G3M1-A4110	15	5.5	5.5	5.5
3G3M1-A4185	3G3M1-A4150	18.5	5.5	5.5	5.5
3G3M1-A4220	3G3M1-A4185	22	5.5	5.5	5.5
-	3G3M1-A4220	30	8.0	8.0	8.0

Model		Maximum applicable motor capacity [kW]	Recommended wire size [mm <sup>2</sup> ]			
HD mode	ND mode		DC reactor connection (P1, P(+))			
			Allowable temperature (Note 1)			Current value [A]
			60°C	75°C	90°C	
3G3M1-A4004	3G3M1-A4004	0.75	2.0	2.0	2.0	1.8
3G3M1-A4007	-	1.1	2.0	2.0	2.0	2.6
-	3G3M1-A4007	1.5	2.0	2.0	2.0	3.6
3G3M1-A4015	3G3M1-A4015	2.2	2.0	2.0	2.0	5.1
3G3M1-A4022	3G3M1-A4022	3	2.0	2.0	2.0	7.1
3G3M1-A4030	3G3M1-A4030	5.5	2.0	2.0	2.0	12.4
3G3M1-A4040	3G3M1-A4040					
3G3M1-A4055	-	7.5	2.0	2.0	2.0	17.6
3G3M1-A4075	3G3M1-A4055	11	3.5	2.0	2.0	25.8
3G3M1-A4110	3G3M1-A4075	15	5.5	3.5	3.5	35.3
3G3M1-A4150	3G3M1-A4110	18.5	8.0	5.5	3.5	43.5
3G3M1-A4185	3G3M1-A4150	22	14.0	5.5	5.5	51.7
3G3M1-A4220	3G3M1-A4185	30	14.0	14.0	8.0	69.8



Model		Maximum applicable motor capacity [kW]	Recommended wire size [mm <sup>2</sup> ]			
HD mode	ND mode		DC reactor connection (P1, P(+))			
			Allowable temperature (Note 1)			Current value [A]
			60°C	75°C	90°C	
-	3G3M1-A4220	37	22.0	14.0	14.0	83.9

Model		Maximum applicable motor capacity [kW]	Recommended wire size [mm <sup>2</sup> ]							
HD mode	ND mode		Brake resistance connection (P(+), DB)							
			HD mode				ND mode			
			Allowable temperature (Note 1)			Current value [A]	Allowable temperature (Note 1)			Current value [A]
60°C	75°C	90°C	60°C	75°C	90°C					
3G3M1-A4004	3G3M1-A4004	0.75	2.0	2.0	2.0	0.4	2.0	2.0	2.0	0.4
3G3M1-A4007	-	1.1	2.0	2.0	2.0	0.6	-	-	-	-
-	3G3M1-A4007	1.5	-	-	-	-	2.0	2.0	2.0	0.6
3G3M1-A4015	3G3M1-A4015	2.2	2.0	2.0	2.0	0.8	2.0	2.0	2.0	0.8
3G3M1-A4022	3G3M1-A4022	3	2.0	2.0	2.0	0.9	2.0	2.0	2.0	0.9
3G3M1-A4030	3G3M1-A4030	5.5	2.0	2.0	2.0	1.3	2.0	2.0	2.0	1.3
3G3M1-A4040	3G3M1-A4040									
3G3M1-A4055	-	7.5	2.0	2.0	2.0	1.9	-	-	-	-
3G3M1-A4075	3G3M1-A4055	11	2.0	2.0	2.0	2.7	2.0	2.0	2.0	2.3
3G3M1-A4110	3G3M1-A4075	15	2.0	2.0	2.0	3.8	2.0	2.0	2.0	3.1
3G3M1-A4150	3G3M1-A4110	18.5	2.0	2.0	2.0	4.5	2.0	2.0	2.0	4.2
3G3M1-A4185	3G3M1-A4150	22	2.0	2.0	2.0	6.2	2.0	2.0	2.0	4.9
3G3M1-A4220	3G3M1-A4185	30	2.0	2.0	2.0	7.2	2.0	2.0	2.0	7.2
-	3G3M1-A4220	37	-	-	-	-	2.0	2.0	2.0	8.0

Model		Maximum applicable motor capacity [kW]	Recommended wire size [mm <sup>2</sup> ]		
HD mode	ND mode		Inverter ground (G)		
			Allowable temperature (Note 1)		
			60°C	75°C	90°C
3G3M1-A4004	3G3M1-A4004	0.75	2.0	2.0	2.0
3G3M1-A4007	-	1.1	2.0	2.0	2.0
-	3G3M1-A4007	1.5	2.0	2.0	2.0
3G3M1-A4015	3G3M1-A4015	2.2	2.0	2.0	2.0
3G3M1-A4022	3G3M1-A4022	3	2.0	2.0	2.0
3G3M1-A4030	3G3M1-A4030	5.5	2.0	2.0	2.0
3G3M1-A4040	3G3M1-A4040				

Model		Maximum applicable motor capacity [kW]	Recommended wire size [mm <sup>2</sup> ]		
			Inverter ground (G)		
HD mode	ND mode		Allowable temperature (Note 1)		
			60°C	75°C	90°C
3G3M1-A4055	-	7.5	2.0	2.0	2.0
3G3M1-A4075	3G3M1-A4055	11	3.5	3.5	3.5
3G3M1-A4110	3G3M1-A4075	15	5.5	5.5	5.5
3G3M1-A4150	3G3M1-A4110	18.5	5.5	5.5	5.5
3G3M1-A4185	3G3M1-A4150	22	5.5	5.5	5.5
3G3M1-A4220	3G3M1-A4185	30	8.0	8.0	8.0
-	3G3M1-A4220	37	8.0	8.0	8.0

● Single-phase 200-V class (Panel internal temperature 40°C or less)

Model		Maximum applicable motor capacity [kW]	Recommended wire size [mm <sup>2</sup> ]							
			Main power supply input (L1/R, L2/S, L3/T)							
HHD mode	HND mode		When DC reactor (DCR) is used				Without DC reactor (DCR)			
			Allowable temperature (Note 1)			Current value [A]	Allowable temperature (Note 1)			Current value [A]
60°C	75°C	90°C	60°C	75°C	90°C					
3G3M1-AB001	-	0.1	2.0	2.0	2.0	1.1	2.0	2.0	2.0	1.8
-	3G3M1-AB001	0.2	2.0	2.0	2.0	2.2	2.0	2.0	2.0	3.3
3G3M1-AB002	-		2.0	2.0	2.0	2.0	2.0	2.0	2.0	3.3
-	3G3M1-AB002	0.4	2.0	2.0	2.0	3.7	2.0	2.0	2.0	4.9
3G3M1-AB004	-		2.0	2.0	2.0	3.5	2.0	2.0	2.0	5.4
-	3G3M1-AB004	0.55	2.0	2.0	2.0	4.6	2.0	2.0	2.0	7.3
3G3M1-AB007	-		0.75	2.0	2.0	2.0	6.4	2.0	2.0	2.0
-	3G3M1-AB007	1.1	2.0	2.0	2.0	9.4	2.0	2.0	2.0	13.8
3G3M1-AB015	-		1.5	2.0	2.0	2.0	11.6	2.0	2.0	2.0
-	3G3M1-AB015	2.2	2.0	2.0	2.0	17.9	2.0	2.0	2.0	20.2
3G3M1-AB022	-		2.0	2.0	2.0	17.5	2.0	2.0	2.0	22.0
-	3G3M1-AB022	3	3.5	2.0	2.0	25.0	3.5	2.0	2.0	26.0
3G3M1-AB037	-		3.7	5.5	3.5	2.0	31.8	8.0	5.5	3.5

Model		Maximum applicable motor capacity [kW]	Recommended wire size [mm <sup>2</sup> ]							
			Inverter output (U, V, W)							
HHD mode	HND mode		HHD mode				HND mode			
			Allowable temperature (Note 1)			Current value [A]	Allowable temperature (Note 1)			Current value [A]
60°C	75°C	90°C	60°C	75°C	90°C					
3G3M1-AB001	-	0.1	2.0	2.0	2.0	1.0	-	-	-	-

Model		Maximum applicable motor capacity [kW]	Recommended wire size [mm <sup>2</sup> ]							
			Inverter output (U, V, W)							
HHD mode	HND mode		HHD mode				HND mode			
			Allowable temperature (Note 1)			Current value [A]	Allowable temperature (Note 1)			Current value [A]
60°C	75°C	90°C	60°C	75°C	90°C					
-	3G3M1-AB001	0.2	-	-	-	-	2.0	2.0	2.0	1.2
3G3M1-AB002	-		2.0	2.0	2.0	1.6	-	-	-	-
-	3G3M1-AB002	0.4	-	-	-	-	2.0	2.0	2.0	1.9
3G3M1-AB004	-		2.0	2.0	2.0	3.0	-	-	-	-
-	3G3M1-AB004	0.55	-	-	-	-	2.0	2.0	2.0	3.5
3G3M1-AB007	-	0.75	2.0	2.0	2.0	5.0	-	-	-	-
-	3G3M1-AB007	1.1	-	-	-	-	2.0	2.0	2.0	6.0
3G3M1-AB015	-	1.5	2.0	2.0	2.0	8.0	-	-	-	-
-	3G3M1-AB015	2.2	-	-	-	-	2.0	2.0	2.0	9.6
3G3M1-AB022	-		2.0	2.0	2.0	11.0	-	-	-	-
-	3G3M1-AB022	3	-	-	-	-	2.0	2.0	2.0	12.0
3G3M1-AB037	-	3.7	2.0	2.0	2.0	17.5	-	-	-	-

Model		Maximum applicable motor capacity [kW]	Recommended wire size [mm <sup>2</sup> ]			
			DC reactor connection (P1, P(+))			
HHD mode	HND mode		Allowable temperature (Note 1)			Current value [A]
			60°C	75°C	90°C	
3G3M1-AB001	-	0.1	2.0	2.0	2.0	1.3
-	3G3M1-AB001	0.2	2.0	2.0	2.0	2.7
3G3M1-AB002	-		2.0	2.0	2.0	2.4
-	3G3M1-AB002	0.4	2.0	2.0	2.0	4.5
3G3M1-AB004	-		2.0	2.0	2.0	4.3
-	3G3M1-AB004	0.55	2.0	2.0	2.0	5.6
3G3M1-AB007	-	0.75	2.0	2.0	2.0	7.8
-	3G3M1-AB007	1.1	2.0	2.0	2.0	11.5
3G3M1-AB015	-	1.5	2.0	2.0	2.0	14.2
-	3G3M1-AB015	2.2	2.0	2.0	2.0	21.9
3G3M1-AB022	-		2.0	2.0	2.0	21.4
-	3G3M1-AB022	3	2.0	2.0	2.0	30.6
3G3M1-AB037	-	3.7	5.5	3.5	3.5	38.9

Model		Maximum applicable motor capacity [kW]	Recommended wire size [mm <sup>2</sup> ]							
			Brake resistance connection (P(+), DB)							
HHD mode	HND mode		HHD mode				HND mode			
			Allowable temperature (Note 1)			Current value [A]	Allowable temperature (Note 1)			Current value [A]
		60°C	75°C	90°C	60°C		75°C	90°C		
3G3M1-AB001	-	0.1	2.0	2.0	2.0	0.3	-	-	-	-
-	3G3M1-AB001	0.2	-	-	-	-	2.0	2.0	2.0	0.2
3G3M1-AB002	-		2.0	2.0	2.0	0.4	-	-	-	-
-	3G3M1-AB002	0.4	-	-	-	-	2.0	2.0	2.0	0.4
3G3M1-AB004	-		2.0	2.0	2.0	0.5	-	-	-	-
-	3G3M1-AB004	0.55	-	-	-	-	2.0	2.0	2.0	0.6
3G3M1-AB007	-	0.75	2.0	2.0	2.0	0.7	-	-	-	-
-	3G3M1-AB007	1.1	-	-	-	-	2.0	2.0	2.0	1.1
3G3M1-AB015	-	1.5	2.0	2.0	2.0	1.4	-	-	-	-
-	3G3M1-AB015	2.2	-	-	-	-	2.0	2.0	2.0	1.5
3G3M1-AB022	-		2.0	2.0	2.0	1.7	-	-	-	-
-	3G3M1-AB022	3	-	-	-	-	2.0	2.0	2.0	1.9
3G3M1-AB037	-	3.7	2.0	2.0	2.0	2.4	-	-	-	-

Model		Maximum applicable motor capacity [kW]	Recommended wire size [mm <sup>2</sup> ]		
			Inverter ground (G)		
HHD mode	HND mode		Allowable temperature (Note 1)		
			60°C	75°C	90°C
		60°C	75°C	90°C	
3G3M1-AB001	-	0.1	2.0	2.0	2.0
-	3G3M1-AB001	0.2	2.0	2.0	2.0
3G3M1-AB002	-		2.0	2.0	2.0
-	3G3M1-AB002	0.4	2.0	2.0	2.0
3G3M1-AB004	-		2.0	2.0	2.0
-	3G3M1-AB004	0.55	2.0	2.0	2.0
3G3M1-AB007	-	0.75	2.0	2.0	2.0
-	3G3M1-AB007	1.1	2.0	2.0	2.0
3G3M1-AB015	-	1.5	2.0	2.0	2.0
-	3G3M1-AB015	2.2	2.0	2.0	2.0
3G3M1-AB022	-		2.0	2.0	2.0
-	3G3M1-AB022	3	2.0	2.0	2.0
3G3M1-AB037	-	3.7	3.5	3.5	3.5

Note 1: At an allowable temperature of 60°C, use 600 V IV insulated wire, at 75°C 600 V HIV insulated wire, and at 90°C 600 V crosslinked polyethylene insulated wire.

Note 2: When the recommended wire size is 38 mm<sup>2</sup>, use crimped terminal model No. 38-6 made by J.S.T. Mfg. Co., Ltd. or an equivalent product (\*1 in table).

Note 3: When the recommended wire size is 60 mm<sup>2</sup>, use crimped terminal model No. 60-6 made by J.S.T. Mfg. Co., Ltd. or an equivalent product (\*2 in table).

### ● Tightening torque

Model		Screw specification					
		Main circuit		For ground		Control power supply auxiliary input (R0, T0)	
		Terminal screw size	Tightening torque [N·m]	Terminal screw size	Tightening torque [N·m]	Terminal screw size	Tightening torque [N·m]
Three-phase 200 V	3G3M1-A2001	M3.5	0.8	M3.5	1.2	-	-
	3G3M1-A2002						
	3G3M1-A2004						
	3G3M1-A2007						
	3G3M1-A2015	M4	1.2	M4	1.8	-	-
	3G3M1-A2022						
	3G3M1-A2037						
	3G3M1-A2055	M5	3	M5	3	-	-
	3G3M1-A2075						
	3G3M1-A2110	M6	3	M6	3	-	-
3G3M1-A2150							
3G3M1-A2185	M6 (No. 3)	5.8	M6 (No. 3)	5.8	M3.5	1.2	
Three-phase 400 V	3G3M1-A4004	M4	1.2	M4	1.8	-	-
	3G3M1-A4007						
	3G3M1-A4015						
	3G3M1-A4022						
	3G3M1-A4030						
	3G3M1-A4040						
	3G3M1-A4055	M5	3	M5	3	-	-
	3G3M1-A4075						
	3G3M1-A4110	M6	3	M6	3	-	-
	3G3M1-A4150						
3G3M1-A4185	M6 (No. 3)	5.8	M6 (No. 3)	5.8	M3.5	1.2	
3G3M1-A4220							
Single-phase 200 V	3G3M1-AB001	M3.5	0.8	M3.5	1.2	-	-
	3G3M1-AB002						
	3G3M1-AB004						
	3G3M1-AB007						
	3G3M1-AB015	M4	1.2	M4	1.8	-	-
	3G3M1-AB022						
	3G3M1-AB037	M5	3	M5	3	-	-

## Wiring for Main Power Supply Input Terminals (L1/R, L2/S, L3/T)

The following describes the wiring for the main power supply input terminals and for peripheral equipment.

### ● Installing molded case circuit breaker

If the inverter's protective function is activated, the inverter internal circuit may be damaged depending on the condition.

Be sure to connect the main power supply input terminals (L1/R, L2/S, L3/T) to the power supply via a molded case circuit breaker (MCCB) according to each inverter.

- When using multiple inverters, install one MCCB per inverter.
- Determine the capacity of the MCCB according to the molded case circuit breaker (MCCB) value shown in the previous table.
- Determine the time characteristic of the MCCB upon due consideration of the time characteristic of the inverter's overheat protection function (150% of the rated output current for one minute).
- If you must share one MCCB with multiple inverters or other equipment, construct a sequence that turns OFF the power supply via the alarm output signal, as shown in the figure below.

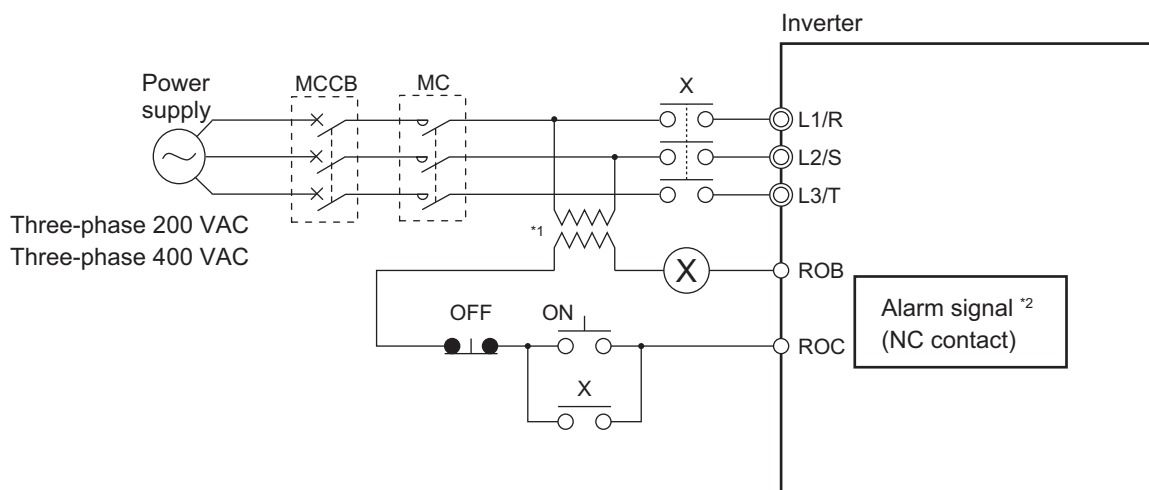

\*1. For 400-V class, connect a 400/200-V transformer.

\*2. Set the Output Terminal [ROA, ROB] Function Selection (E27) to "1099: AL (Alarm signal)."

### ● Installing earth leakage breaker

When selecting the earth leakage breaker to use between the power supply and the main power supply input terminals (L1/R, L2/S, L3/T), consider the following.

High-frequency leakage current from inverter

The inverter produces a high-frequency leakage current due to its high-speed output switching.

In general, a leakage current of approx. 100 mA will flow for the power cable length of 1 m per inverter. Moreover, an additional leakage current of approx. 5 mA will flow with the increasing length by 1 m.

Therefore, an earth leakage breaker to use in the power input section must be dedicated for the inverter, which removes high-frequency leakage current and detects only the leakage current in a frequency range that is dangerous to the human body.

- Select a special earth leakage breaker for the inverter with a sensitivity current rating of 10 mA or higher per inverter.

- If you use a general earth leakage breaker (which detects high-frequency leakage current), select one with a sensitivity current rating of 200 mA or higher per inverter and an operation time of 0.1 s or longer.

#### Leakage current from EMC noise filter

The EMC noise filter is designed to comply with European CE standards.

Specifically, it is designed to meet the neutral-point grounding requirement of the European power supply specifications. Therefore, using the EMC noise filter with the phase S grounding causes an increase of leakage current.

For use with the phase S grounding, it is recommended to use the Input Noise Filter.

- OMRON currently plans to support the EMC noise filters for the 3G3M1 Series.

### ● Installing magnetic contactor

To shut off the main circuit power supply with a sequence, you can use a magnetic contactor (MC) on the inverter side closer than a molded case circuit breaker (MCCB).

- Do not attempt to run/stop the inverter by turning ON/OFF a magnetic contactor. Instead, use the RUN command signal (FW/RV) via the control circuit terminal block of the inverter.
- Construct a sequence that turns OFF the power supply via the alarm output signal of the inverter.
- To use one or more braking resistors/regenerative braking units, construct a sequence that turns OFF a magnetic contactor via a thermal relay contact in each unit.

### ● Inrush current flow when the inverter power supply is turned ON

When the inverter power supply is turned ON, the charging current, which is called inrush current, flows in the main circuit board capacitor.

The table below shows the reference values at a power supply voltage of 200 V or 400 V when the power supply impedance is low. Take this into consideration when selecting the inverter power supply.

- With a low-speed no-fuse breaker, an inrush current 10 times the rated current can flow for 20 ms.
- To turn ON the power supply for multiple inverters simultaneously, select a no-fuse breaker whose 20-ms allowable current rating is greater than the total inrush current of the inverters.

Single-phase/Three-phase 200-V class	
3G3M1-□	Inrush current value (Ao-p)
A2001 to A2037 AB001 to AB022	12
A2055, A2075, AB037	126
A2110, A2150	251
A2185	145

Three-phase 400-V class	
3G3M1-□	Inrush current value (Ao-p)
A4004 to A4040	13
A4055, A4075	41
A4110, A4150	81
A4185, A4220	148

### ● Main power supply phase loss and single-phase input

To use a single-phase power supply, use a single-phase 200-V class inverter.

Using a single-phase power supply to supply power to a three-phase 200-V or three-phase 400-V class inverter may cause damage to the inverter.

Be sure to check that the three-phase power supply is wired properly before using the inverter.

### ● Power supply environment

In the following cases, the internal converter module (rectifier) may be damaged.

Take countermeasures such as installing an AC reactor on the main circuit input side of the inverter.

- The power supply voltage unbalance factor is 3% or more.
- The power supply capacity is at least 10 times larger than the inverter capacity and, at the same time, 500 kVA or more.
- Rapid change in the power supply voltage occurs.

Example) When the phase advance capacitor is turned ON/OFF, the inverter may detect an over-voltage or the rectifier may be damaged.

### ● Installing input surge absorber

When using an inductive load (such as a magnetic contactor, magnetic relay, magnetic valve, solenoid, or electromagnetic brake), use a surge absorber or diode together.

### ● Installing input noise filter

The inverter performs high-speed output switching, which may cause the noise flow from the inverter to power supply lines that negatively affects on peripheral equipment.

Therefore, it is recommended to use an input noise filter to reduce noise flowing out to power supply lines.

This also helps reduce noise that enters the inverter from power supply lines.

Input noise filter for inverter (for general use)

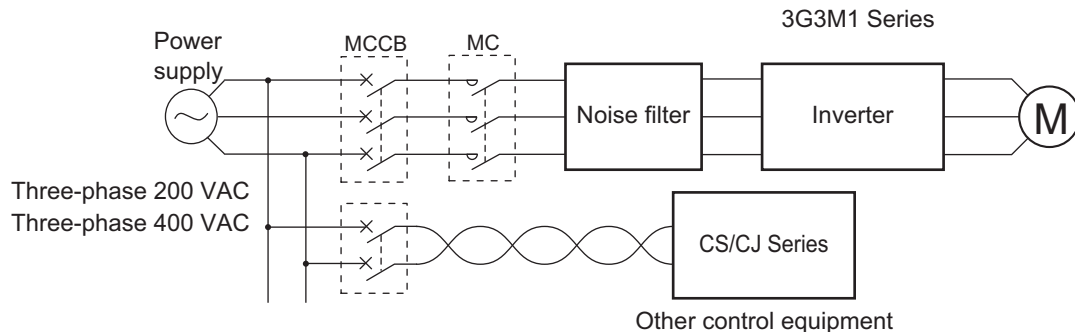

## Wiring for Ground Terminal (G ⊕)

To prevent electric shock, be sure to ground the inverter and the motor.

The 200-V class should be connected to the ground terminal under type-D grounding conditions (conventional type 3 grounding conditions: 100 Ω or less ground resistance), the 400-V class should be connected to the ground terminal under type-C grounding conditions (conventional special type 3 grounding conditions: 10 Ω or less ground resistance).

For the ground cable, use the applicable cable or a cable with a larger diameter. Make the cable length as short as possible.

When several inverters are connected, the ground cable must not be connected across several inverters or looped. Otherwise, the inverters and peripheral control equipment may malfunction.



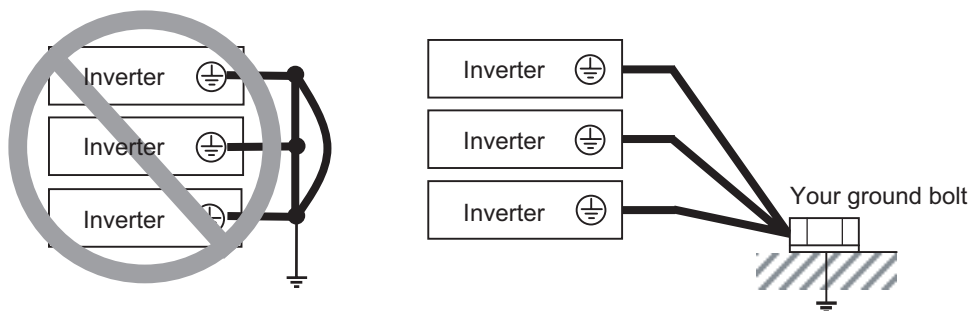

## Harmonic Current Measures and DC/AC Reactor Wiring (P1, P(+))

In recent years, there is an increasing concern about harmonic currents generated from industrial machinery.

Harmonic measures must be implemented as *Guideline of Countermeasures Taken by Users against Higher Harmonics Received at High Voltages or Extremely High Voltages* was established by the Ministry of International Trade and Industry (current: Ministry of Economy, Trade and Industry) in September, 1994.

The following provides an overview of harmonics and measures against harmonics implemented in this inverter.

### ● Harmonics

The voltage or current whose frequency is an integral multiple of certain standard frequency (base frequency) is called a harmonic.

If a commercial power supply frequency of 60 Hz (50 Hz) is the reference frequency, the harmonics of that signal is:

- x2 = 120 Hz (100 Hz),
- x3 = 180 Hz (150 Hz),
- and so on.

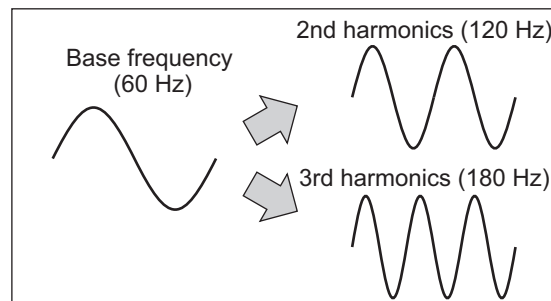

### ● Reason why harmonics cause problems

As the number of harmonics increases, the waveform of the commercial supply has more distortion. This distortion causes the malfunction of the connected equipment or leads to abnormal heat generation.

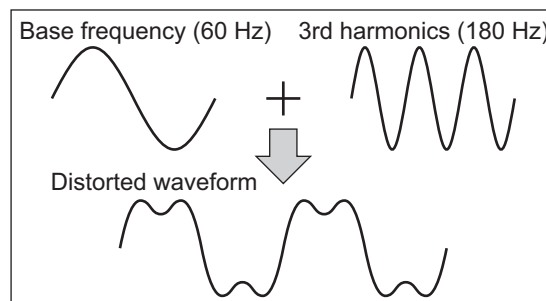

## ● Causes of harmonics

- General electrical equipment internally converts AC input power (commercial power) into DC power. At this time, harmonic currents occur because of the difference in the current flow direction between AC power and DC power.
- In an AC-to-DC power conversion, the rectifier converts the input power into a unidirectional voltage, which is then smoothed by the capacitor. As a result, the current charged into the capacitor has a waveform that contains harmonic components.
- This inverter also performs an AC-to-DC conversion as with other electrical equipment, which allows current with harmonic components to flow. In particular, the inverter has more current than other equipment, so the number of harmonic components in current is larger.

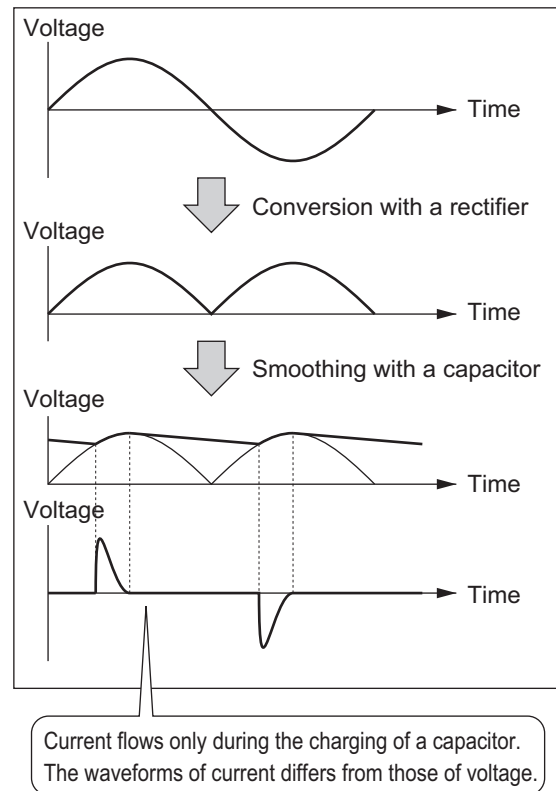

## ● DC/AC reactor

To suppress harmonic currents, use the DC (direct current) and AC (alternating current) reactors. The DC/AC reactor functions to suppress a steep change in the current.

The DC reactor has a higher harmonics suppression ability, so even higher suppression ability can be expected when used in conjunction with the AC reactor.

Suppressing harmonic currents also leads to the improvement in the power factor on the input or output side of the inverter.

## ● Before wiring

The DC reactor is connected to the DC power supply located inside the inverter.

Before wiring, be sure to turn OFF the power supply and make sure that the charge indicator is not lit.

Do not touch the interior of the inverter during inverter operation. Doing so may result in electric shock or burn injury.

By factory default, a short-circuit bar is connected between the terminals P1 and P(+). Before connecting the DC reactor, remove this short-circuit bar.

Note that the length of the DC reactor connection cable must be 10 m or shorter.

Remove the short-circuit bar only if you connect the DC reactor for use.

If you remove the short-circuit bar with the DC reactor unconnected, the inverter cannot operate because no power is supplied to its main circuit.

## ● Wiring method

With DC reactor

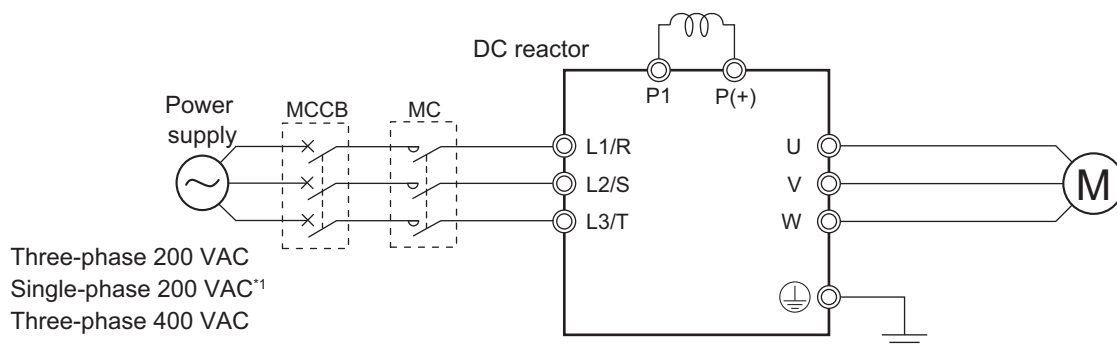

\*1. Connect to the terminals L1/L and L2/N on the single-phase 200-VAC inverter.

With DC reactor and AC reactor

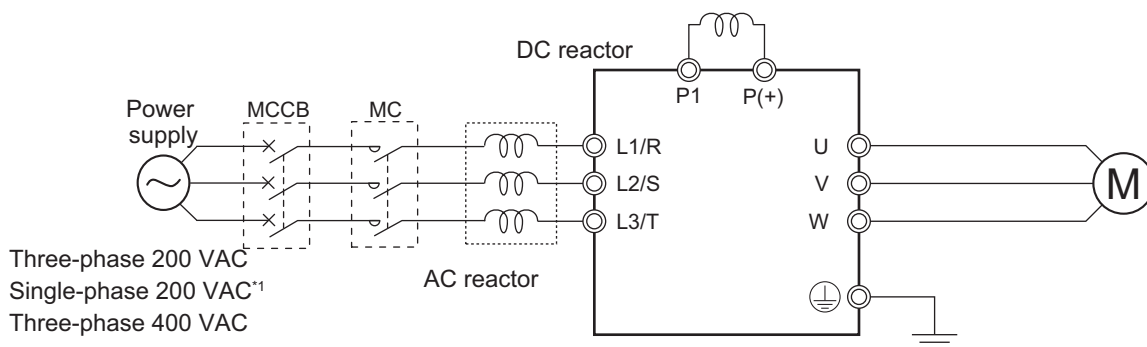

\*1. Connect to the terminals L1/L and L2/N on the single-phase 200-VAC inverter.

## ● Effect of reactors

Through the use of the DC/AC reactor, the rate of harmonic current occurrences can be reduced as shown in the table of typical examples below (excerpt from a JEMA document).

Measure against harmonics	Harmonic current occurrence rate [%]							
	5th	7th	11th	13th	17th	19th	23th	25th
None (Inverter only)	65	41	8.5	7.7	4.3	3.1	2.6	1.8
AC reactor	38	14.5	7.4	3.4	3.2	1.9	1.7	1.3
DC reactor	30	13	8.4	5	4.7	3.2	3.0	2.2
With DC and AC reactors	28	9.1	7.2	4.1	3.2	2.4	1.6	1.4

## ● Guideline for reactor selection

When implementing measures against harmonics, first install a DC reactor and evaluate its effect. Then, if further reduction is required, add an AC reactor.

To implement harmonic countermeasures in consideration of the power supply environment (such as rapid change in the power supply voltage), first install an AC reactor and evaluate its effect. If further reduction is required, add a DC reactor.

If you have multiple inverters and use the AC reactor, use one AC reactor for each inverter. Using only one AC reactor for more than one inverter does not provide sufficient reduction

## Wiring for Inverter Output Terminals (U, V, W)

---

The following describes the wiring for the inverter output terminals (U, V, W).

- **Never connect power supply to output terminals**

Never connect the power supply to the output terminals U, V, W.

The inverter is damaged internally if power supply voltage is applied to the output terminals.

- **Never short or ground output terminals**

Do not touch the output terminals with bare hand or contact the output wires with the inverter's case. Doing so may result in electric shock or ground fault.

Be careful not to short the output wires.

- **Do not use phase advance capacitors and noise filters for general-purpose power supplies or for the input side**

Never connect a phase advance capacitor or LC/RC noise filter for general-purpose power supplies to the output circuit.

Doing so may result in damage to the inverter or burnout of these parts.

- **Do not use magnetic switches**

Do not connect any magnetic switch or magnet contactor to the output circuit.

If a load is connected to the inverter when running, the inverter's overcurrent protection circuit is activated due to the inrush current.

- **Precautions for connecting more than one motor to inverter's output terminals**

If connecting more than one motors to the output terminals of the inverter, note the following three points.

- Make sure that the rated current of the inverter is higher than the sum of the rated current values of the connected motors.
- The inverter cannot provide overload protection for individual motors, because it only detects a sum of the current values for all the connected motors.  
Install a thermal relay for each motor. The RC value of each thermal relay must be 1.1 times larger than the rated current of the motor.
- Set the inverter to detect only overloading that occurred in it by setting the Electronic Thermal Level to the rated output current of the inverter.

- **Installing output noise filter**

Connecting a noise filter to the output side of the inverter enables the reduction of radio noise and inductive noise.

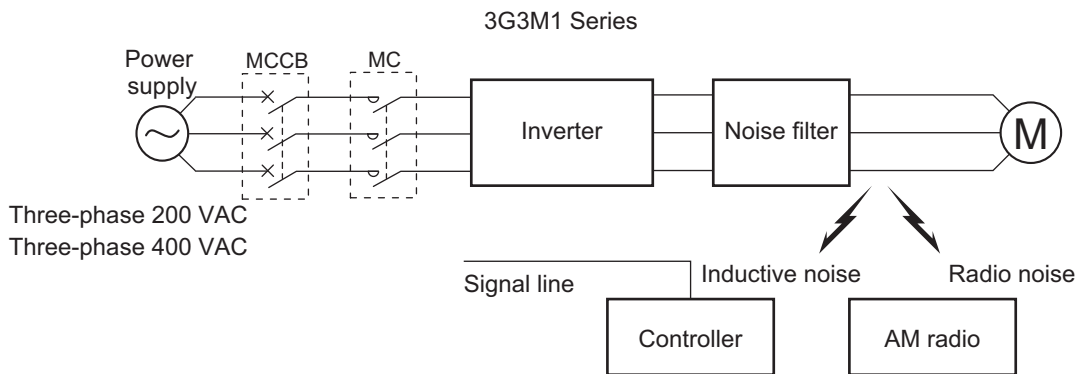

Noise	Description
Inductive noise	Produced by electromagnetic induction, this noise causes malfunction of control equipment due to noise in signal lines.
Radio noise	The electromagnetic waves emitted from the inverter body or cables cause noise in radio receivers.

● **Measures against inductive noise**

In addition to the noise filter described above, you can suppress the inductive noise produced on the output side by connecting a bundle of wires through a grounded metal conduit. Moreover, moving the conduit 30 cm or more away from signal lines helps the reduction of inductive noise.

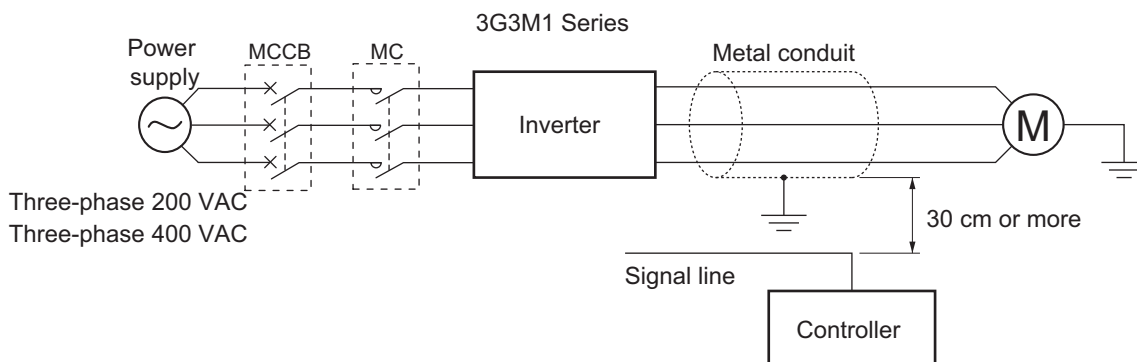

● **Measures against radio noise**

Besides the I/O wires, radio noise is radiated from the inverter itself. This radio noise can be reduced by installing noise filters on both the input and output sides of the inverter and by installing and shielding the inverter body in a grounded iron enclosure etc. Keep the cables between the inverter and the motor as short as possible.

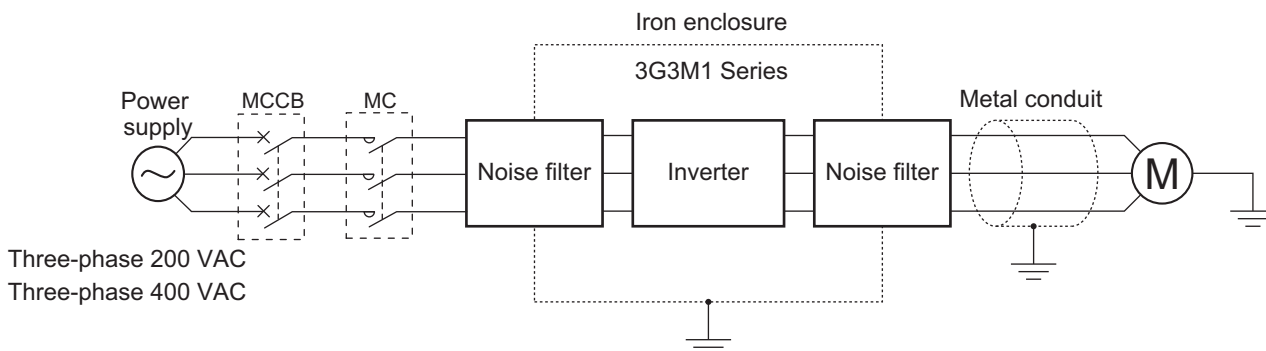

### ● Cable length between inverter and motor

If the length of the cables between the inverter and the motor is long, consider how to address the following problems.

- Voltage drop in output cables

As the cable length between the inverter and the motor increases, the resistance in the cables becomes higher and accordingly the amount of voltage drop in the inverter output voltage becomes larger. This causes a decrease in the voltage that is applied to the motor, which results in a low output torque.

If the cables are long, take measures to reduce the resistance, for example, by selecting cables whose wire diameter is larger than specified.

- Surge in long cables

If the cable length exceeds 20 m, a surge voltage (approx. 1200 V max. for 400-V class) may be generated at the motor terminal depending on the stray capacitance or inductance of the cable, which may result in motor burnout.

In particular, when using a 400-V class inverter with a cable length of over 20 m, it is recommended to use a dedicated inverter motor. Dedicated inverter motors are designed to support the above surge voltage level.

- Leakage current from output cables

As the cable length between the inverter and the motor increases, stray capacitance increases between the inverter output and the ground. The increase in the stray capacitance on the output side of the inverter causes an increase of the high-frequency leakage current.

This high-frequency leakage current may negatively affect on the current detector in the inverter output section or peripheral equipment.

It is recommended to keep the wiring distance between the inverter and the motor at 100 m or shorter. If your system configuration requires the wiring distance of over 100 m, take measures to decrease the stray capacitance. The applicable measures are such as not wiring in a metal duct and using a separate cable for each phase.

In addition, set a carrier frequency appropriate for the wiring distance between the inverter and the motor according to the table below.

Capacity	Wiring distance between inverter and motor
3.7 kW max.	50 m max.
5.5 kW min.	100 m max.

## External Braking Resistor Connection Terminal (P(+), DB)

When driving a load with a large inertia or a vertical axis, regenerated energy is fed back to the inverter when it is decelerating or generating downward movement.

If the amount of regenerative energy exceeds the amount allowable for the inverter, an overvoltage is detected. Use braking resistors or regenerative braking units to prevent this.

### ● Using built-in regenerative braking circuit

All models of the 3G3M1 Series Inverter have built-in regenerative braking circuit.

To improve the braking capacity, connect the optional external braking resistor to these terminals (P(+), DB).

- Wiring diagram

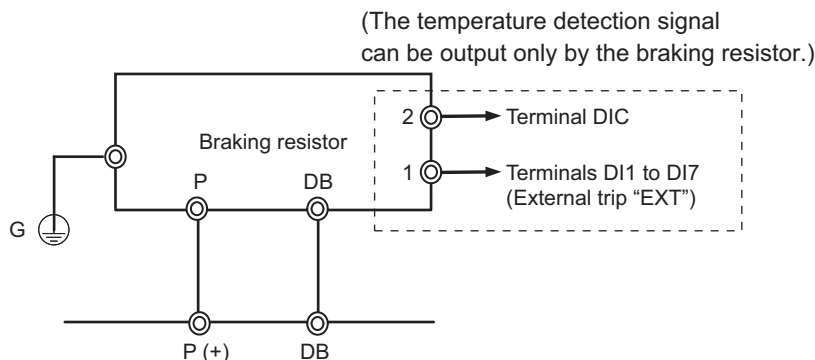

## 2-3-5 Wiring for Control Circuit Terminals

### Wiring for Control Circuit Terminals

- The AIC terminal (common terminal of the analog input), DIC terminal (common terminal of the analog input) and DOC terminal (common terminal of the digital output) are mutually insulated from each other.  
Do not short-circuit or ground these common terminals.  
In addition, do not ground these common terminals via external equipment.  
When finished wiring, check the external equipment ground conditions.
- For wiring to the control circuit terminals, use twisted-pair shielded cables (recommended diameter: 0.75 mm<sup>2</sup>). Connect the sheathed shielded cable to each common terminal. The cable length should be 20 m or shorter.
- Twist a cable connected to the terminal PTC (thermistor input) with a cable of the terminal AIC individually, and separate them from other AIC common cables. Since the current flowing through the thermistor is weak, separate the thermistor cable from main circuit cable (power cable). The thermistor connection cable should be 20 m or shorter.
- To use a relay for a multifunction output terminal, connect a surge-absorbing diode in parallel with the coil.
- The control circuit terminal block has three rows of terminals. Start wiring from the lower terminals. Wiring from the upper terminals makes it difficult to wire the lower terminals.

### Arrangement of Control Circuit Terminal Blocks

The arrangement of terminals on the control circuit terminal block is shown below.

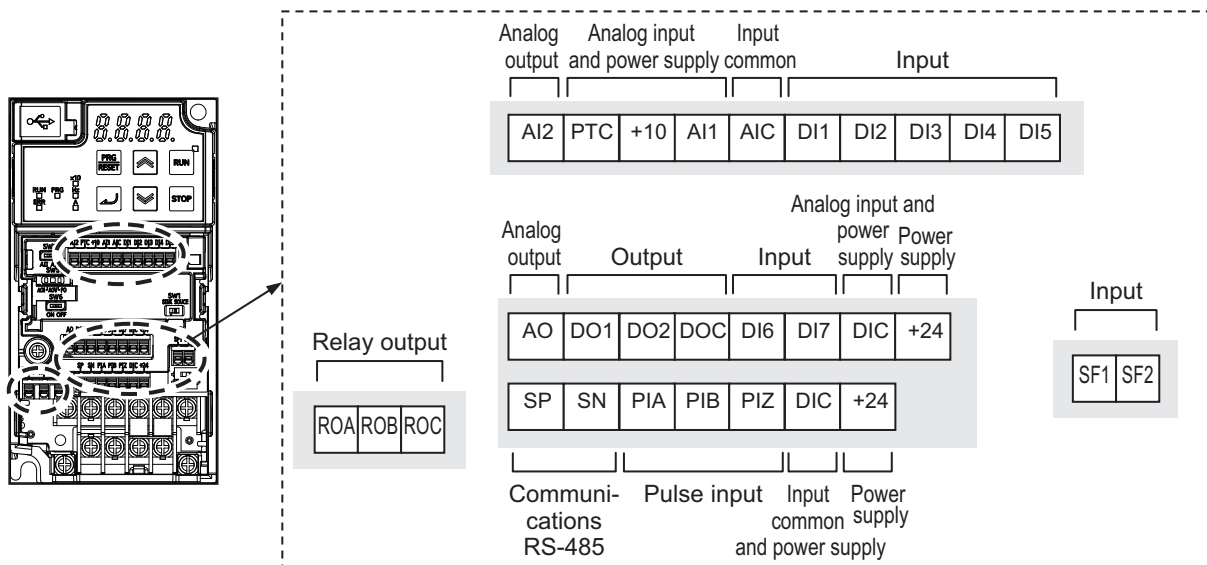

	Applicable wire		
	Solid wire mm <sup>2</sup> (AWG)	Stranded wire mm <sup>2</sup> (AWG)	Ferrule mm <sup>2</sup> (AWG)
Other than below	0.2 to 1.5 (AWG24 to 16)	0.2 to 1.0 (AWG24 to 17)	0.25 to 0.75 (AWG24 to 18)
ROA/ROB/ROC SF1/SF2	0.2 to 1.5 (AWG24 to 16)	0.2 to 1.0 (AWG24 to 17)	0.25 to 0.75 (AWG24 to 18)

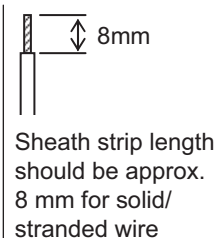

## Recommended Terminal

To improve ease of wiring and reliability in connection, it is recommended to use ferrules with the following specifications for signal wires.

Wire size mm <sup>2</sup> (AWG)	Ferrule type*1	L [mm]	φd [mm]	φD [mm]
0.25 (24)	AI 0.25-8YE	12.5	0.8	2.0
0.34 (22)	AI 0.34-8TQ	12.5	0.8	2.0
0.5 (20)	AI 0.5-8WH	14	1.1	2.5
0.75 (18)	AI 0.75-8GY	14	1.3	2.8

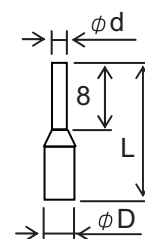

\*1. Manufacturer: PHOENIX CONTACT  
Crimping tool: CRIMPFOX 6

## Wiring Method

- 1** Push in the orange colored portion of the control circuit terminal block with a flat-blade screwdriver (blade width: 2.5 mm max.) to open the wire insertion hole.
- 2** With the flat-blade screwdriver pushed in, insert the wire or ferrule into the wire insertion (round) hole.
- 3** Remove the flat-blade screwdriver to clamp the wire.



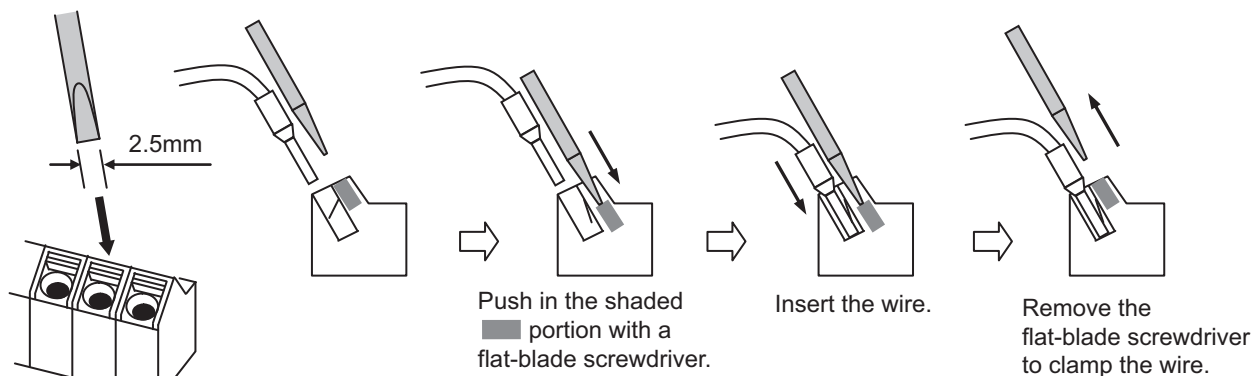

**Note** To disconnect, pull out the wire with the shaded (■) portion pushed in with a flat-blade screwdriver.

## Selecting Input Control Logic

By factory default, the multifunction input terminals are set to sink logic (NPN).

To change the input control logic to source logic (PNP), switch SW1 on the control printed circuit board to the SOURCE side.

## Multifunction Input Terminals and Programmable Controller Connection

### ● Sink logic

On products not provided with a selector switch when an external power supply is used, DIC must never be wired to the 0 V or SC terminal on the PLC to prevent a connection that will allow the external power supply to be charged by the internal 24 VDC voltage of the inverter. When the inverter malfunctions, for example, due to the voltage difference with the external power supply, review the DIC connection destination.

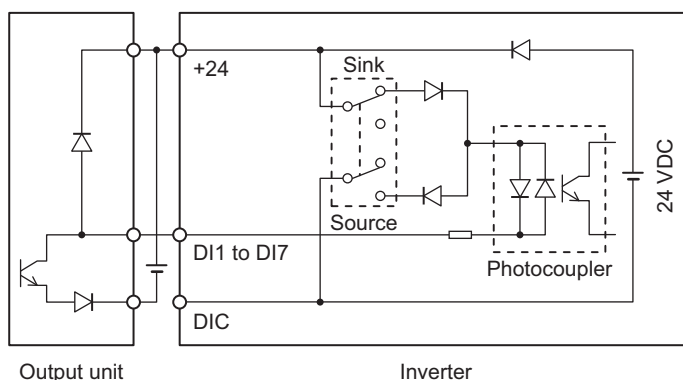

### ● Source logic

With use by an external power supply using source logic, take care not to connect the 24 V terminal to the external power supply or the PLC on the other side. A malfunction might arise due to the voltage difference between the internal power supply and the external power supply.

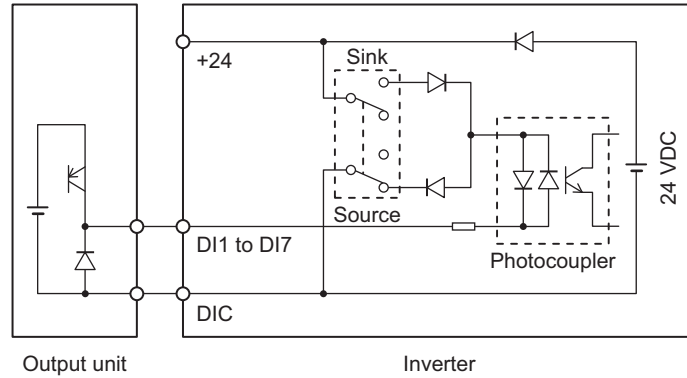

## Multifunction Output Terminals and Programmable Controller Connection

### ● Sink logic

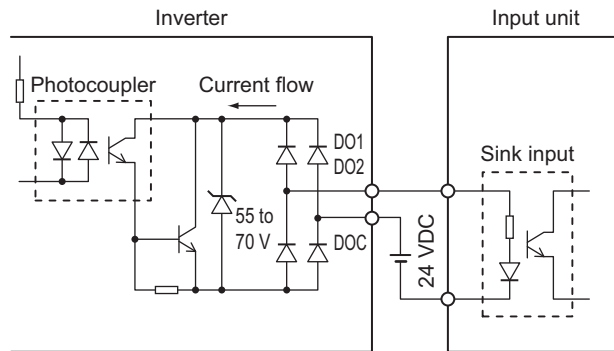

### ● Source logic

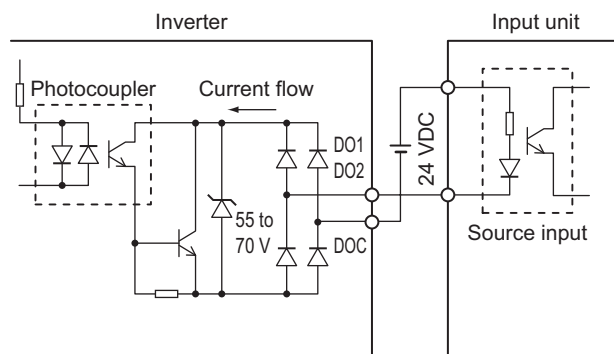

## 2-3-6 Recommended Encoder and Its Wiring

For the pulse train input function of the 3G3M1 Series inverter, be sure to use a complementary output type encoder.

In addition, for encoder cable connection, always use a shielded cable and connect it to the DIC terminal of the inverter's control circuit terminal block.

If an open collector output encoder is used, the inverter may not recognize the rotation in the forward or reverse direction. This is because, as the length of the encoder cable increases, its stray

capacitance becomes larger, which causes the inverter to falsely recognize the crosstalk signal from the encoder.

### ● Complementary output

Complementary output is a method of outputting via two transistors.

The wiring is connected to the 0 V side when output is ON and to the power supply side when output is OFF.

This design does not allow the wiring to be left open (at high impedance) as in the case of open collector output encoders.

Therefore, this provides a stable output from the encoder.

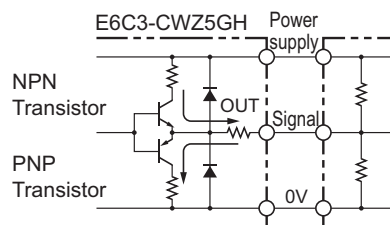

### ● Recommended product

E6C3-CWZ5GH (Manufacturer: OMRON)

## Encoder Input

For pulse train input, use the pulse train input PIA and PIB terminals of the control circuit terminals. Be sure to use a complementary output type encoder.

## Wiring for Phase A and B 90° Phase Difference Pulse Train (d14 = 2 or 3)

Connect the phase A and B 90° phase difference pulse train as shown in the diagram below.

- Connect the phase A signal to the pulse input PIA terminal and the phase B signal to the pulse train input PIB terminal.
- The +24 V terminal of the inverter control circuit terminal block is for a 100 mA maximum 24 V power supply. This terminal can be used for the encoder power supply if the consumption current for the input terminals in use and the encoder power supply is allowable. However, note that this terminal must be isolated from any 24 V system power supply for other than the encoder and inverter.

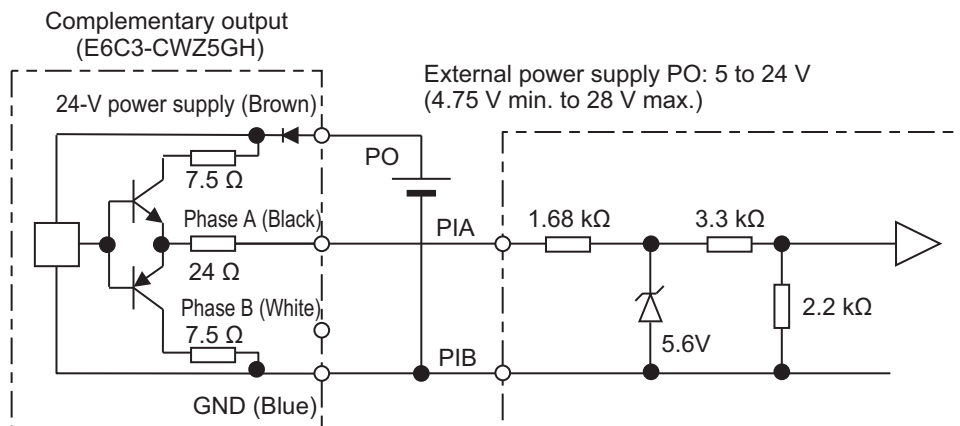

## Wiring for Single-phase Pulse Signal and Direction Signal (d14 = 0)

Connect the single-phase pulse signal or single-phase pulse + direction signal as shown in the diagram below.

- Connect the direction signal to the pulse train input PIA terminal and the single-phase pulse to the pulse train input PIB terminal.
- The +24 V terminal of the inverter control circuit terminal block is for a 100 mA maximum 24 V power supply. This terminal can be used for the encoder power supply if the consumption current for the input terminals in use and the encoder power supply is allowable. However, note that this terminal must be isolated from any 24 V system power supply for other than the encoder and inverter.

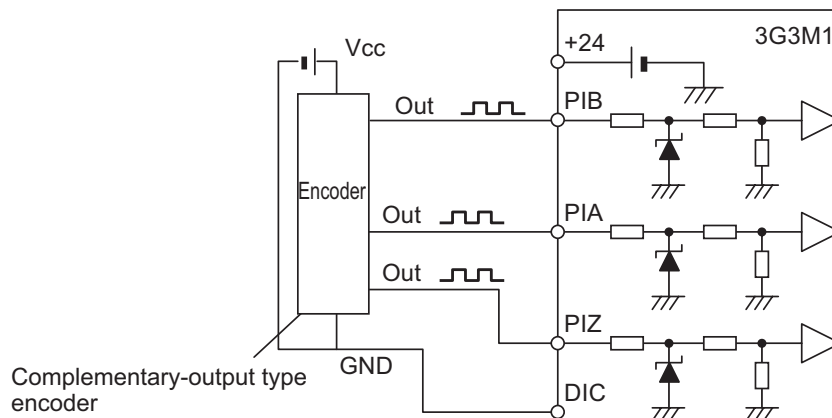
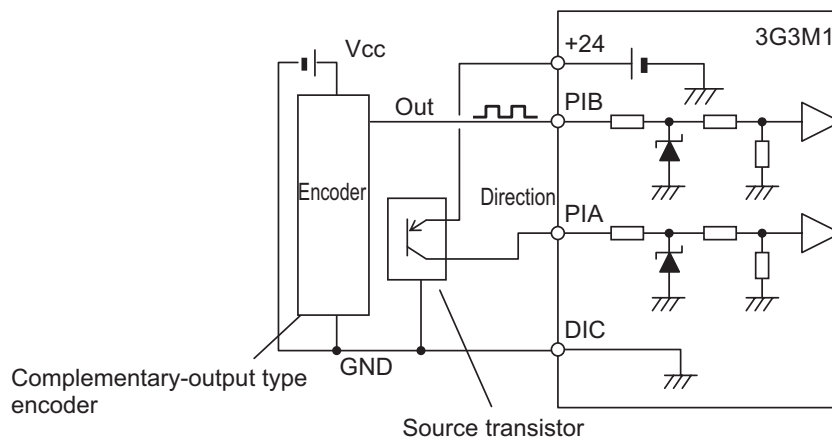
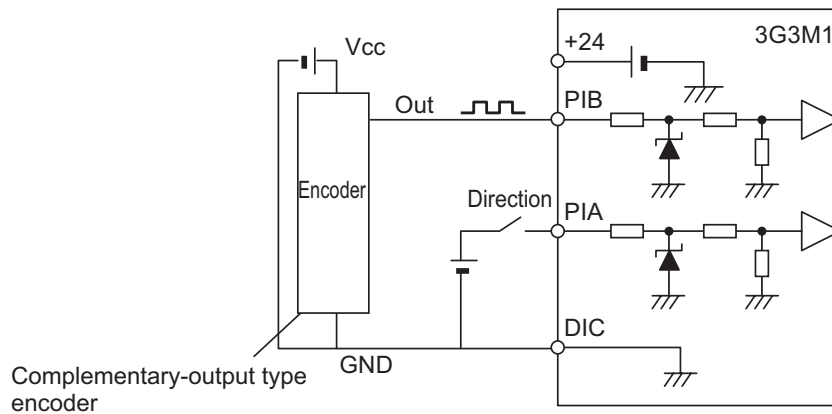

## Wiring for Forward Rotation Pulse/Reverse Rotation Pulse (d14 = 1)

Connect the forward rotation pulse/reverse rotation pulse as shown in the diagram below.

- Connect the forward rotation pulse to the pulse train input PIA terminal and the reverse rotation pulse to the pulse train input PIB terminal.
- The +24 V terminal of the inverter control circuit terminal block is for a 100 mA maximum 24 V power supply. This terminal can be used for the encoder power supply if the consumption current for the input terminals in use and the encoder power supply is allowable. However, note that this terminal must be isolated from any 24 V system power supply for other than the encoder and inverter.

### 2-3-7 Wiring for RS-485 Communications Terminal Block

This inverter has RS-485 communications terminals on its control circuit terminal block.

It uses the Modbus communication protocol to establish communications with external controllers.

This section describes the wiring procedure for the RS-485 communications terminal block and the installation of the terminating resistor.

## Wiring for RS-485 Communications Terminal Block

On the control circuit terminal block, the following RS-485 communications terminals are provided.

Terminal symbol	Terminal name	Function
SN	Modbus terminal (RS-485)	Negative-side send/receive terminal for RS-485 communications.
SP	Modbus terminal (RS-485)	Positive-side send/receive terminal for RS-485 communications.

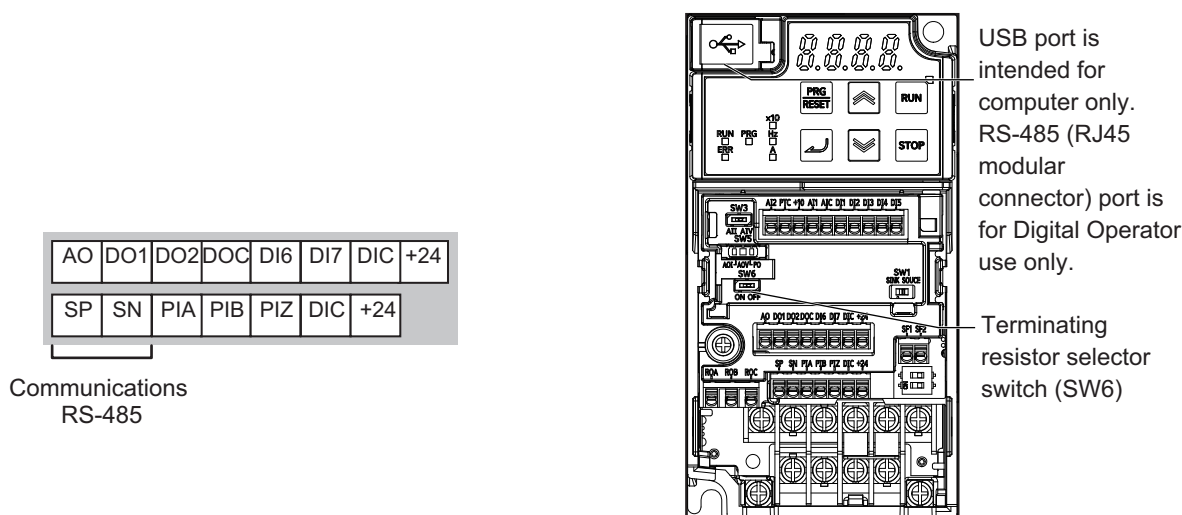

## Terminating Resistor Setting

Connect the inverters parallel to each other as shown below and, only on the terminal inverter, turn ON the terminating resistor selector switch.

Even if you have only one inverter connected, turn ON the terminating resistor selector switch.

Selecting a terminating resistor appropriate to the cable impedance improves the terminating effect. For this inverter, however, turning ON the terminating resistor selector switch enables the built-in terminating resistor (112 Ω).

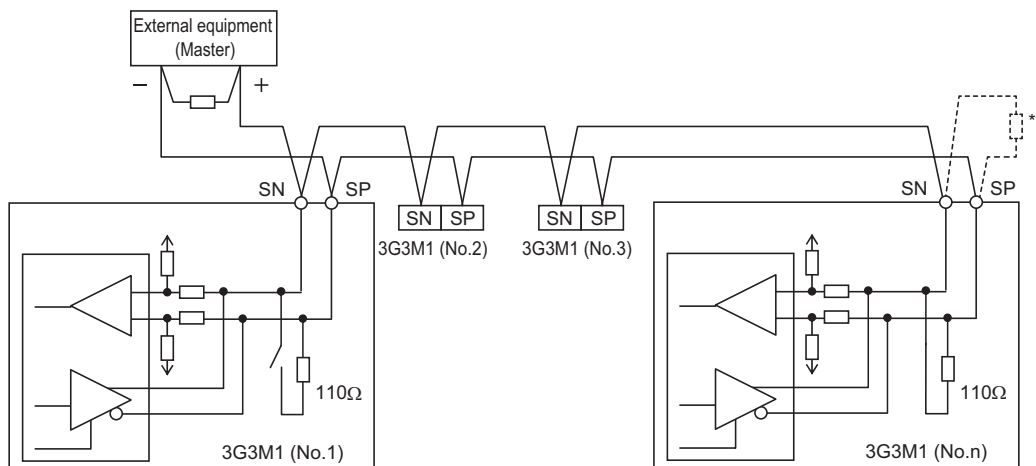

\*1. If the communications are unstable, install a terminating resistor appropriate to the impedance of the cable to each cable end. The resistance of the terminating resistor built into this inverter is 110 Ω.

## 2-3-8 Safety Function

The safety function is designed so that the safety stop function of category 0 (uncontrolled stop) specified in IEC 60204-1 is used to meet the safety standards of PL-e under ISO 13849-1.

The safety input function allows the inverter output when current flows in both the terminals SF1 and SF2.

When the safety input function is activated, in compliance with the above standards, the output transistor operation of the inverter

is stopped safely (by shutting off its output). As a result, the motor stops with free run.

For details, refer to 7-6 *Safety Function* on page 7-69.

**Note** This inverter meets ISO13849-1 PLc when the EDM function is disabled.

## Safety Function Settings

To use the safety function, it must be set beforehand. By default, the safety function is disabled.

Use of the safety function is enabled by turning SW9 OFF.

Turn OFF both of the safety function selector switch SW9 when the inverter power supply is turned OFF. When using EDM output (safety monitor output), set "102: EDM (safety monitor)" at the multi-function output terminal.

When the safety function is used→Both OFF

When the safety function is not used→Both ON

When only one is ON, the logic of the SF1 and SF2 signals no longer matches and this causes an ECF alarm.

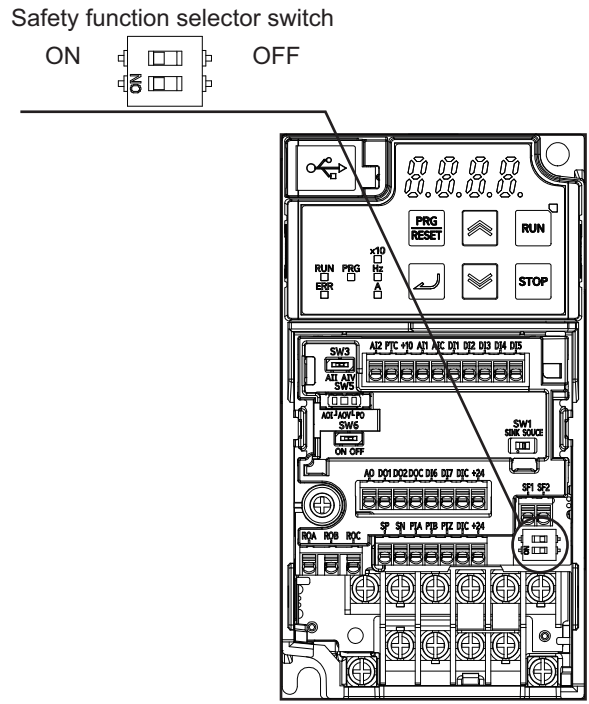

**Wiring Example**

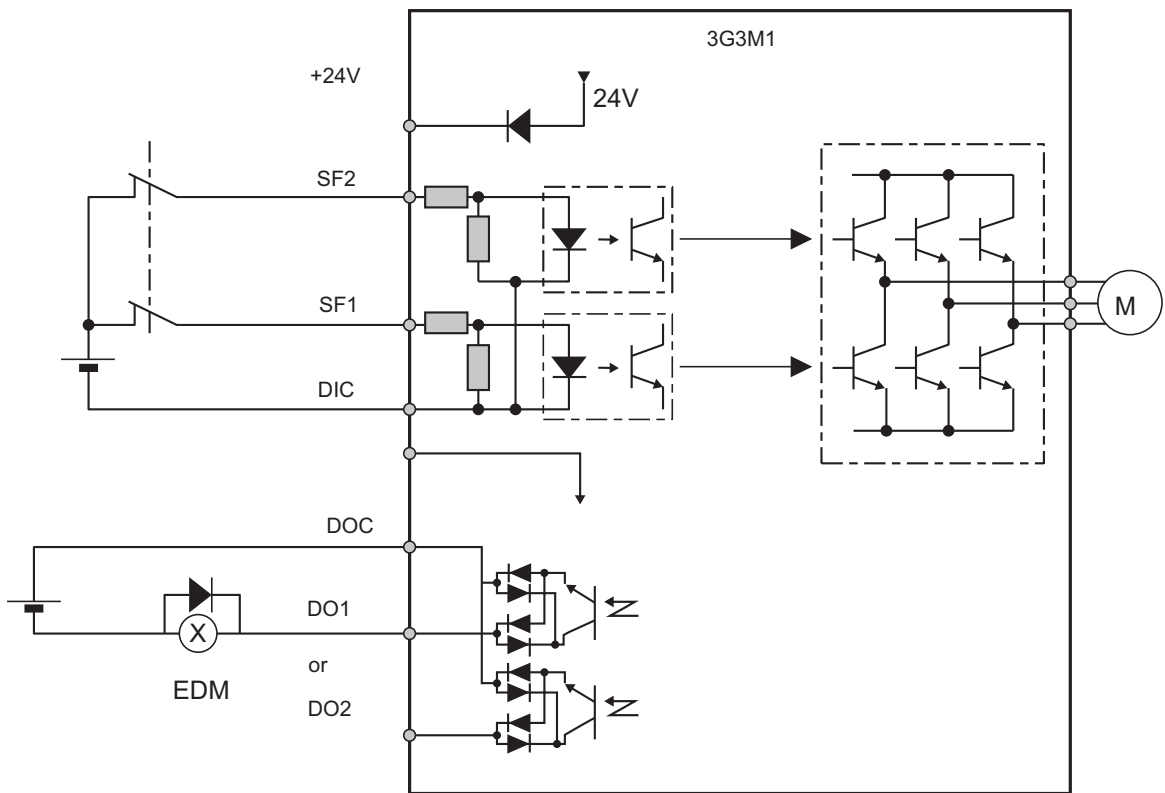

In the factory default state, operation is always enabled by the short-circuit bars as shown in the figure above.

For details on connection with safety devices, refer to 7-6 Safety Function on page 7-69.

## 2-4 Others

### 2-4-1 Korean Radio Regulations (KC)

사용자 안내문

이 기기는 업무용 환경에서 사용할 목적으로 적합성평가를 받은 기기로서 가정용 환경에서 사용하는 경우 전파간섭의 우려가 있습니다.

Guide for Users

This equipment has been evaluated for conformity in a commercial environment.

When used in a residential environment, it may cause radio interference.

### 2-4-2 Compliance with EU Directives and UKCA

This section provides conditions that must be met for compliance with European EU Directives.

Take measures to meet the conditions shown here for the entire system as well as peripheral equipment.

For the system that incorporates this inverter, perform the final compliance verification separately on the whole system.

## Directives and Legislation

EU Declaration of Conformity
OMRON declares that 3G3M1 Series conform with the requirements of the following EU Directive EMC Directive 2014/30/EU Machinery Directive 2006/42/EC
UKCA Declaration of Conformity
OMRON declares that 3G3M1 Series conform with the requirements of the following UK legislation (2016 No.1091) Electromagnetic Compatibility Regulations (2008 No.1597) Supply of Machinery (Safety) Regulations

## Applicable Standards

The 3G3M1 Series complies with the following standards.

Standard	Applicable standard
EMC	EN 61800-3:2004/A1:2012
Electrical Safety (Machinery Directive/LVD)	EN 61800-5-1:2007/A1:2017
Functional Safety (Machinery Directive)	The safety functions in 3G3M1 Series are designed and manufactured in accordance with the following standards: <ul style="list-style-type: none"> <li>• EN 61800-5-2: 2017</li> <li>• EN ISO 13849-1: 2015, PL e / Safety category 3</li> </ul>

- This product is designed for industrial environments.  
If used in a residential environment, it may cause radio interference. In that case, it is necessary to take appropriate measures against radio interference.
- This product is not intended to be connected to a power grid that supplies residential facilities.



## Concepts of Compliance

### **WARNING**

There are conditions for compliance with the EU Low Voltage Directive and Machinery Directive. Strictly observe the conditions listed in the instruction manual or user's manual.

Not doing so may result in a serious injury due to an electric shock or fire.



#### ● **EMC**

OMRON products are the electrical devices incorporated and used in various machines or manufacturing equipment. For this reason, OMRON makes efforts to manufacture products that meet the related EMC standards so that the machines or equipment in which they are incorporated can easily comply with the EMC standards.

The 3G3M1 Series Inverter complies with EN61800-3 when installed and wired to equipment according to the methods described below. However, the customer's machines and equipment vary in type, and in addition, EMC performance depends on the configuration and electrical characteristics of mechanical parts, and the configuration, wiring and location of the control panel. This does not allow OMRON to verify compliance under the customer's usage conditions.

Please perform the final verification on the EMC compliance of your machines or the entire system at your own responsibility.

#### ● **EMC noise filters**

OMRON is currently preparing a line up of EMC noise filters.

#### ● **Wiring for power supply**

Keep the ground cable as short as possible.

Place the inverter and the noise filter on the same earth (ground) plate.

Always connect the power supply input terminals (L1/R, L2/S, L3/T) of the inverter to the power supply via an EMC noise filter.

Keep the cable between the inverter and the EMC noise filter as short as possible (40 cm maximum).

Connection Example

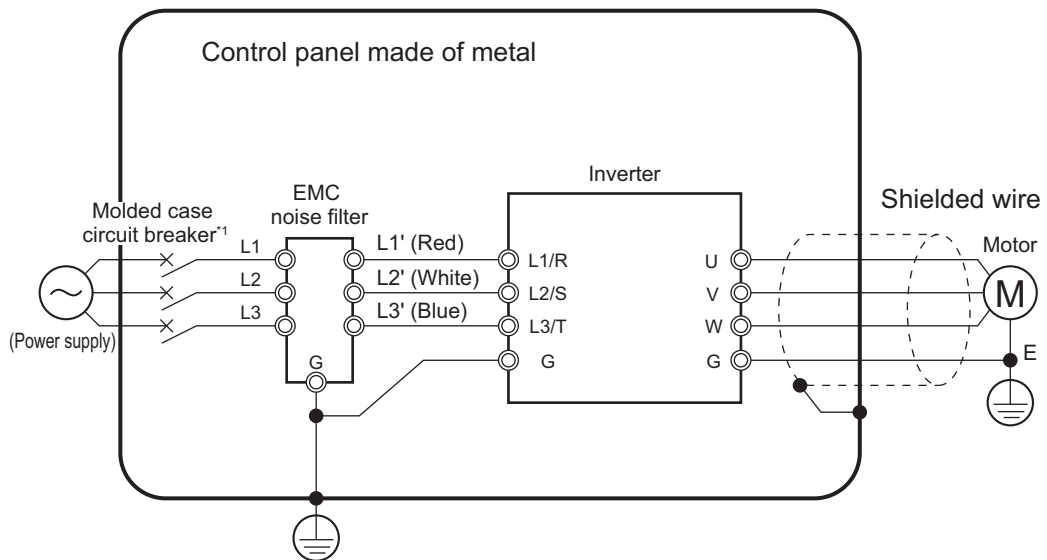

### ● Wiring between inverter and motor

For cables between the inverter and motor, be sure to use shield braided cables. Keep the cables as short as possible.

### ● Measures against noise for compliance with EMC Directive

- Keep the power cable of the inverter and the EMC noise filter wiring as short as possible. Use a shield braided cable.
- For the shield braided cable, use a tinned copper shielded cable with a shield factor of 85%.
- Be sure to connect the ground cable separately from the shielded cable. Use the ground cable as thick and short as possible to wire.
- Use shield braided cables for connection between the inverter and the motor. Keep the cables as short as possible at a length 20 m or less, with the cable shield grounded at each end. Installing a clamp filter near the inverter output terminals is an effective countermeasure.
- Ground the motor frame, the shield of the motor cable, and the terminal housing adequately. The motor terminal housing may not contact with the chassis due to the rubber bushing or the screw hole for motor ground terminal may be coated. Check the contact performance. If there is any problem, take measures to enhance contact performance.
- Use shielded cables for wiring to the control circuit terminal blocks and communications lines and ground the shield of each cable on the inverter side. Grounding the cables at each end may increase the effect.
- Connect the cable shield directly to a ground plate with a conductive cable clamp. At this time, keep the shield strip length as short as possible.
- Make the contact area between the EMC noise filter/inverter and the ground plate as large as possible to enhance contact performance. At this time, remove the paint etc. from the ground plate.
- For the metal control panel door, use a conductive gasket to improve the shielding effect.
- In the same control panel, do not install equipment that generates non-EMC-compliant electromagnetic waves.
- Avoid conductor loops that encompass large areas.

- As a measure against harmonic distortion, an AC/DC reactor or harmonic suppression equipment is required.
- Avoid placing noise-generating cables (such as power cables and motor cables of the inverter) in parallel with signal cables and allow a clearance of at least 25 cm between them. If you cannot avoid crossing two types of cables, keep them at right angles to each other.

### ● Wiring example for single-phase 200-V class

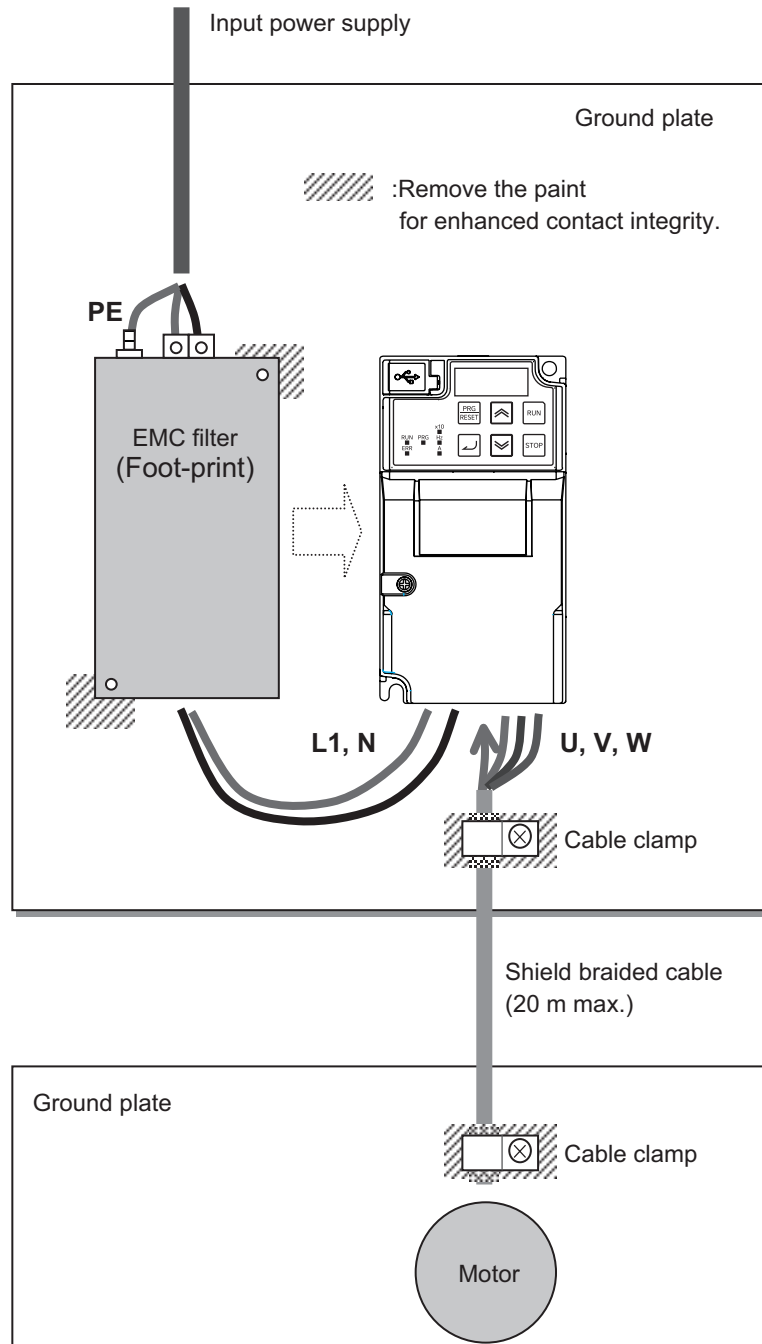

### ● Low-voltage directive (electrical safety)

The 3G3M1 Series Inverter complies with EN61800-5-1 when installed and wired to equipment according to the methods described below.

- The 3G3M1 Series Inverter is an open type device. Be sure to install it inside the control panel.

- The power supply and voltage (SELV) with reinforced or double insulation should be used for wiring to the control circuit terminals.
- To satisfy electrical safety requirements, the inverter must be protected with fuses or a molded case circuit breaker (MCCB) in case a short-circuiting accident occurs. Be sure to install fuses or a molded case circuit breaker (MCCB) on the power supply side of the inverter.  
The fuses, if used, should be one of the UL-compliant Class-J product listed in *2-4-3 UL/cUL Standards Cautions* on page 2-76.
- Use one molded case circuit breaker (MCCB), or one set of fuses, per inverter.
- Use the crimp terminal with an insulation sleeve to connect to the main circuit terminals.

### ● Compliance with EU Low Voltage Directive

- **Be sure to ground the ground terminal  G. Do not use only an earth leakage circuit breaker\* (RCD: Residual-current-operated protective device/ELCB: Earth Leakage Circuit Breaker) as protection against electric shock. Also, use ground cable of the size of the power line or larger diameter.**  
**\*With overcurrent protection function**
- **To protect against high voltage that accompanies inverter damage and the risk of accidents, install a fuse having the rating specified in the table below on the power supply side.**
  - Breaking capacity 10 kA or more, rated voltage 500 V or less

Power supply line	Standard applicable motor (kW)	Inverter model	Specifications	Fuse rating (A)
Three-phase 200 V	0.1	3G3M1-A2001	HHD	50 (IEC 60269-4)
	0.2		HND	
	0.4	3G3M1-A2002	HHD	50 (IEC 60269-4)
			HND	
	0.75	3G3M1-A2004	HHD	50 (IEC 60269-4)
			HND	
	1.1	3G3M1-A2007	HHD	50 (IEC 60269-4)
			HND	
	1.5	3G3M1-A2015	HHD	80 (IEC 60269-4)
	2.2		HND	
	3	3G3M1-A2022	HHD	125 (IEC 60269-4)
			HND	
	3.7	3G3M1-A2037	HHD	125 (IEC 60269-4)
	5.5		HND	
	7.5	3G3M1-A2055	HHD	160 (IEC 60269-4)
			HND	
	11	3G3M1-A2075	HHD	200 (IEC 60269-4)
			HND	
	15	3G3M1-A2110	HHD	200 (IEC 60269-4)
			HND	
18.5	3G3M1-A2150	HHD	250 (IEC 60269-4)	
		HND		
22	3G3M1-A2185	HHD	250 (IEC 60269-4)	
		HND		

Power supply line	Standard applicable motor (kW)	Inverter model	Specifications	Fuse rating (A)
Three-phase 400 V	0.4	3G3M1-A4004	HHD	50 (IEC 60269-4)
	0.75		HND	
			HD	
			ND	
	1.1	3G3M1-A4007	HHD	50 (IEC 60269-4)
			HND	
			HD	
	1.5	3G3M1-A4015	ND	50 (IEC 60269-4)
			HHD	
	2.2	3G3M1-A4015	HND	50 (IEC 60269-4)
			HD	
			ND	
	3.0	3G3M1-A4022	HHD	63 (IEC 60269-4)
			HND	
			HD	
			ND	
	4.0	3G3M1-A4030	HHD	63 (IEC 60269-4)
			HND	
			HD	
			ND	
	5.5	3G3M1-A4040	HHD	63 (IEC 60269-4)
			HND	
			HD	
			ND	
7.5	3G3M1-A4055	HHD	100 (IEC 60269-4)	
		HND		
		HD		
11	3G3M1-A4075	HHD	100 (IEC 60269-4)	
		HND		
	3G3M1-A4110	HHD	125 (IEC 60269-4)	
		HND		
15	3G3M1-A4075	ND	100 (IEC 60269-4)	
		HND		
	3G3M1-A4110	HND	125 (IEC 60269-4)	
		HD		
3G3M1-A4150	HHD	160 (IEC 60269-4)		

Power supply line	Standard applicable motor (kW)	Inverter model	Specifications	Fuse rating (A)
Three-phase 400 V	18.5	3G3M1-A4110	ND	125 (IEC 60269-4)
		3G3M1-A4150	HND	160 (IEC 60269-4)
			HD	
	3G3M1-A4185	HHD	160 (IEC 60269-4)	
	22	3G3M1-A4150	ND	160 (IEC 60269-4)
			HND	
		HD		
	3G3M1-A4220	HHD	200 (IEC 60269-4)	
	30	3G3M1-A4185	ND	160 (IEC 60269-4)
			HND	
HD				
3G3M1-A4220	HHD	200 (IEC 60269-4)		
37		ND		
Single-phase 200 V	0.1	3G3M1-AB001	HHD	50 (IEC 60269-4)
	0.2		HND	
	0.4	3G3M1-AB002	HHD	50 (IEC 60269-4)
			HND	
	0.55	3G3M1-AB004	HHD	50 (IEC 60269-4)
			HND	
	0.75	3G3M1-AB007	HHD	50 (IEC 60269-4)
	1.1		HND	
	1.5	3G3M1-AB015	HHD	125 (IEC 60269-4)
	2.2		HND	
	3	3G3M1-AB022	HHD	125 (IEC 60269-4)
			HND	
	3.7	3G3M1-AB037	HHD	160 (IEC 60269-4)

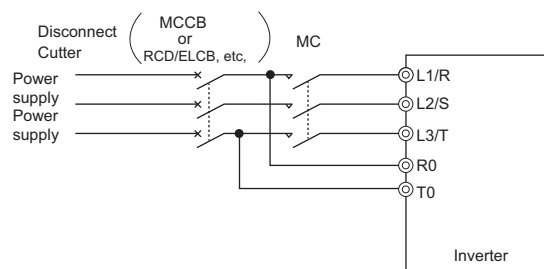

- Use a molded case circuit breaker (MCCB), residual current device (RCD) or earth leakage circuit breaker (ELCB), and magnetic contactor (MC) that are compliance with EN or IEC Standards.
- When using a residual current device (RCD) or earth leakage circuit breaker (ELCB) as protection against electric shock through direct or indirect contact with the power line or node, be sure to install a RCD or ELCB of type B (DC capable) model on the input side (primary side) of the inverter.

Power supply line	Standard applicable motor (kW)	Inverter model	Specifications	Molded case circuit breaker (MCCB)* <sup>1</sup>		Earth leakage circuit breaker (RCD/ELCB)* <sup>1</sup>			
				Rated current		Rated current		Sensitivity current* <sup>2</sup>	Max. fault loop impedance
				With DC reactor	Without DC reactor	With DC reactor	Without DC reactor		
Three-phase 200 V	0.1	3G3M1-A2001	HHD	5	5	5	5	30 mA	200 Ω
	0.2		HND						
	0.4	3G3M1-A2002	HHD						
		3G3M1-A2004	HHD						
	0.75	3G3M1-A2007	HND	10	10	10	10		
			HHD						
	1.1	3G3M1-A2015	HND	10	10	10	10		
	1.5		HHD						
	2.2		HND						
	2.2	3G3M1-A2022	HHD	20	30	20	30		
		3	HND						
	3.7	3G3M1-A2037	HHD	30	40	30	40		
	5.5	3G3M1-A2055	HND						
			HHD						
	7.5	3G3M1-A2075	HND	40	75	40	75		
			HHD						
	11	3G3M1-A2110	HND	50	100	50	100		
			HHD						
	15	3G3M1-A2150	HND	75	125	75	125		
HHD									
18.5	3G3M1-A2185	HND	100	150	100	150			
		HHD							
22		HND		175		175			

- \*1. The frame size and model of MCCB, RCD or ELCB (with overcurrent protection function) change according to the capacity of the power transformer. For details on selection method, refer to related technical data.
- \*2. The sensitivity current setting of the TT system differs according to each country. Follow the instructions of the relevant authority.

Power supply line	Standard applicable motor (kW)	Inverter model	Specifications	Molded case circuit breaker (MCCB) <sup>*1</sup>		Earth leakage circuit breaker (RCD/ELCB) <sup>*1</sup>								
				Rated current		Rated current		Sensitivity current <sup>*2</sup>	Max. fault loop impedance					
				With DC reactor	Without DC reactor	With DC reactor	Without DC reactor							
Three-phase 400 V	0.4	3G3M1-A4004	HHD	5	5	5	5	30 mA	20 Ω					
	0.75		HND											
			HD											
			ND											
		3G3M1-A4007	HHD											
	HND													
	HD													
	ND													
	1.1	3G3M1-A4015	HHD							10	10	10		
	1.5		HND											
			HD											
			ND											
		2.2	HHD											
	HND													
	HD													
	ND													
	3.0	3G3M1-A4022	HHD	10	15	10	15							
			HND											
			HD											
			ND											
	4.0	3G3M1-A4030	HHD							20	20			
			HND											
			HD											
			ND											
5.5	3G3M1-A4040	HHD	15					30	15			30		
		HND												
		HD												
		ND												
7.5	3G3M1-A4055	HHD		20	40	20	40							
		HND												
		3G3M1-A4075								HD				
										HHD				
11	3G3M1-A4055	ND								30	50		30	50
		3G3M1-A4075												
				HD										
				HHD										
3G3M1-A4110	HHD													



Power supply line	Standard applicable motor (kW)	Inverter model	Specifications	Molded case circuit breaker (MCCB)* <sup>1</sup>		Earth leakage circuit breaker (RCD/ELCB)* <sup>1</sup>				
				Rated current		Rated current		Sensitivity current* <sup>2</sup>	Max. fault loop impedance	
				With DC reactor	Without DC reactor	With DC reactor	Without DC reactor			
Three-phase 400 V	15	3G3M1-A4075	ND	40	60	40	60	100 mA	20 Ω	
		3G3M1-A4110	HND							
			HD							
		3G3M1-A4150	HHD							
	18.5	3G3M1-A4110	ND		75	75				
		3G3M1-A4150	HND							
			HD							
		3G3M1-A4185	HHD							
	22	3G3M1-A4150	ND	50	100	50	100			
		3G3M1-A4185	HND							
			HD							
		3G3M1-A4220	HHD							
	30	3G3M1-A4185	ND	75	125	75	125			
3G3M1-A4220		HND								
		HD								
		ND								
37			100		100					

\*1. The frame size and model of MCCB, RCD or ELCB (with overcurrent protection function) change according to the capacity of the power transformer. For details on selection method, refer to related technical data.

\*2. The sensitivity current setting of the TT system differs according to each country. Follow the instructions of the relevant authority.

Power supply line	Standard applicable motor (kW)	Inverter model	Specifications	Molded case circuit breaker (MCCB)* <sup>1</sup>		Earth leakage circuit breaker (RCD/ELCB)* <sup>1</sup>			
				Rated current		Rated current		Sensitivity current* <sup>2</sup>	Max. fault loop impedance
				With DC reactor	Without DC reactor	With DC reactor	Without DC reactor		
Single-phase 200 V	0.1	3G3M1-AB001	HHD	5	5	5	5	30 mA	200 Ω
	0.2		HND						
	0.4	3G3M1-AB002	HHD	10	10	10	10		
		3G3M1-AB004	HND						
	0.55	3G3M1-AB007	HHD	10	15	10	15		
	0.75		HND						
	1.1	3G3M1-AB015	HHD	15	20	15	20		
	1.5		HND						
	2.2	3G3M1-AB022	HHD	30	30	30	30		
	3		HND						
3.7	3G3M1-AB037	HHD	40	60	40	60			

\*1. The frame size and model of MCCB, RCD or ELCB (with overcurrent protection function) change according to the capacity of the power transformer. For details on selection method, refer to related technical data.

\*2. The sensitivity current setting of the TT system differs according to each country. Follow the instructions of the relevant authority.

- Use the inverter in an environment that does not exceed pollution degree 2. In pollution degree 3 or 4 environments, install the inverter in a panel that satisfies IP rating IP54 or higher.
- To prevent operators from electric shock caused by live parts, install the inverter, AC reactor (ACR) or DC reactor (DCR), and input filter or output filter inside a panel with IP2X or higher. When an operator can easily touch the panel, ensure that the protection grade of the top surface of the panel is IP4X or higher.
- Do not directly connect copper wire to the ground terminal. Use tin-plated or equivalent-plated crimped terminals for connections.
- When the inverter is used at locations 2,000 m or higher above sea level, the insulation of the control circuit is the basic insulation. The inverter cannot be used at locations 3,000 m above sea level.
- Use wires stipulated in IEC60364-5-52.

Power supply line	Standard applicable motor (kW)	Inverter model	Specifications	Molded case circuit breaker (MCCB) or earth leakage circuit breaker (RCD/ELCB) rated current*1		Recommended wire size (mm <sup>2</sup> )									
				With DC reactor	Without DC reactor	For main circuit									
						Main power supply input [L1/R, L2/S, L3/T]*2		Inverter ground [⊖] *2*3		Inverter output [U, V, W]*2	For DC reactor connection [P1, P(+)]	For braking resistor connection [P(+), DB]*2	For control circuit terminal	Control power supply auxiliary input R0, T0	
						With DC reactor	Without DC reactor	With DC reactor	Without DC reactor						
Three-phase 200 V	0.1	3G3M1-A2001	HHD	5	5	2.5	2.5	2.5	2.5	2.5	2.5	2.5	0.7	-	
	0.2		HND												
	0.4	3G3M1-A2002	HHD												
	0.75	3G3M1-A2004	HHD	10	10	2.5	2.5	2.5	2.5	2.5	2.5	2.5	5		
		3G3M1-A2007	HND												
	1.1	3G3M1-A2015	HHD	10	15	2.5	2.5	2.5	2.5	2.5	2.5	5			
	1.5	3G3M1-A2015	HND										20		
	2.2	3G3M1-A2022	HHD	20	30	2.5	2.5	2.5	2.5	2.5	2.5	2.5	5		
	3	3G3M1-A2022	HND												
	3.7	3G3M1-A2037	HHD	30	40	4	4	4	4	4	4	4	5		
	5.5	3G3M1-A2037	HND												50
	7.5	3G3M1-A2055	HHD	40	75	6	10	6	10	6	10	10	10		5
		3G3M1-A2055	HND												
	11	3G3M1-A2075	HHD	50	100	10	16	10	16	10	16	16	16		5
		3G3M1-A2110	HND												
	15	3G3M1-A2110	HHD	75	125	16	25	16	16	16	16	25	25		5
		3G3M1-A2150	HND												
	18.5	3G3M1-A2150	HHD	100	150	25	35	25	35	25	35	35	25		5
22	3G3M1-A2185	HND	175												

- \*1. The frame size and model of MCCB, RCD or ELCB (with overcurrent protection function) change according to the capacity of the power transformer. For details on selection method, refer to related technical data.
- \*2. The recommended size of wire to the main circuit terminal is the size when PVC wire having an allowable temperature of 70°C and a rated voltage of 600 V is used, and the ambient temperature is 40°C.
- \*3. Only one wire of recommended size can be connected to the ground terminal.

Power supply line	Standard applicable motor (kW)	Inverter model	Specifications	Molded case circuit breaker (MCCB) or earth leakage circuit breaker (RCD/ELCB) rated current*1		Recommended wire size (mm <sup>2</sup> )									
				With DC reactor	Without DC reactor	Main power supply input [L1/R, L2/S, L3/T]*2		Inverter ground [⊕] <sup>*2*3</sup>		Inverter output [U, V, W]*2	For DC reactor connection [P1, P(+)]	For braking resistor connection [P(+), DB]*2	For control circuit terminal	Control power supply auxiliary input R0, T0	
						With DC reactor	Without DC reactor	With DC reactor	Without DC reactor						
Three - phase 400 V	0.4	3G3M1-A4004	HHD	5	5	2.5	2.5	2.5	2.5	2.5	2.5	2.5	0.75	-	
	0.75		HND												
			HD												
			ND												
	1.1	3G3M1-A4007	HHD												
			HND												
			HD												
	1.5		ND												
	2.2	3G3M1-A4015	HHD												10
			HND												
			HD												
			ND												
	3.0	3G3M1-A4022	HHD	10	15										
			HND												
			HD												
ND															
4.0	3G3M1-A4030	HHD	20												
		HND													
		HD													
		ND													
5.5	3G3M1-A4040	HHD	15	30											
		HND													
		HD													
		ND													
7.5	3G3M1-A4055	HHD	20	40	4										
		HND													
		HD													
		3G3M1-A4075	HHD												

Power supply line	Standard applicable motor (kW)	Inverter model	Specifications	Molded case circuit breaker (MCCB) or earth leakage circuit breaker (RCD/ELCB) rated current*1		Recommended wire size (mm <sup>2</sup> )									
						For main circuit						Inverter output [U, V, W]*2	For DC reactor connection [P1, P(+)]	For braking resistor connection [P(+), DB]*2	For control circuit terminal
				Main power supply input [L1/R, L2/S, L3/T]*2		Inverter ground [⊕]*2*3		With DC reactor	Without DC reactor	With DC reactor	Without DC reactor				
				With DC reactor	Without DC reactor	With DC reactor	Without DC reactor								
Three phase 400 V	11	3G3M1-A4055	ND	30	50	4	6	4	6	4	4	2.5	0.75	-	
		3G3M1-A4075	HND												
		3G3M1-A4110	HD												
	15	3G3M1-A4110	ND	40	69	6	6	6	6	6	6	10	2.5	0.75	-
		3G3M1-A4110	HND												
		3G3M1-A4150	HD												
	18.5	3G3M1-A4110	ND	40	75	10	16	10	16	10	10	10	2.5	0.75	-
		3G3M1-A4150	HND												
		3G3M1-A4185	HD												
	22	3G3M1-A4075	ND	50	100	16	25	16	16	16	16	25	2.5	0.75	-
		3G3M1-A4185	HND												
		3G3M1-A4220	HD												
	30	3G3M1-A4185	ND	75	125	16	25	16	16	16	16	25	2.5	0.75	-
		3G3M1-A4220	HND												
		3G3M1-A4220	HD												
37	3G3M1-A4220	ND	100		25	35			25						

\*1. The frame size and model of MCCB, RCD or ELCB (with overcurrent protection function) change according to the capacity of the power transformer. For details on selection method, refer to related technical data.

\*2. The recommended size of wire to the main circuit terminal is the size when PVC wire having an allowable temperature of 70°C and a rated voltage of 600 V is used, and the ambient temperature is 40°C.

\*3. Only one wire of recommended size can be connected to the ground terminal.

Power supply line	Standard applicable motor (kW)	Inverter model	Specifications	Molded case circuit breaker (MCCB) or earth leakage circuit breaker (RCD/ELCB) rated current*1		Recommended wire size (mm <sup>2</sup> )											
						For main circuit										For control circuit terminal	Control power supply auxiliary input R0, T0
						Main power supply input [L1/R, L2/S, L3/T]*2		Inverter ground [⊕]*2*3		Inverter output [U, V, W]*2	For DC reactor connection [P1, P(+)]	For braking resistor connection [P(+), DB]*2					
With DC reactor	Without DC reactor	With DC reactor	Without DC reactor	With DC reactor	Without DC reactor												
Single-phase 200 V	0.1	3G3M1-AB001	HHD	5	5	2.5	2.5	2.5	2.5	2.5	2.5	2.5	0.75	-			
	0.2		HND														
	0.4	3G3M1-AB002	HHD		10												
		3G3M1-AB004	HND	10													
	0.55		HHD		15												
	0.75	3G3M1-AB007	HND	15	20												
	1.5	3G3M1-AB015	HHD	30	30										4	4	
		3G3M1-AB022	HND	20													
	3.0		HHD	30	40										4	4	6
	3.7	3G3M1-AB037	HHD	40	60										6	10	6

- \*1. The frame size and model of MCCB, RCD or ELCB (with overcurrent protection function) change according to the capacity of the power transformer. For details on selection method, refer to related technical data.
- \*2. The recommended size of wire to the main circuit terminal is the size when PVC wire having an allowable temperature of 70°C and a rated voltage of 600 V is used, and the ambient temperature is 40°C.
- \*3. Only one wire of recommended size can be connected to the ground terminal.

• Use this product on the following power supply system.

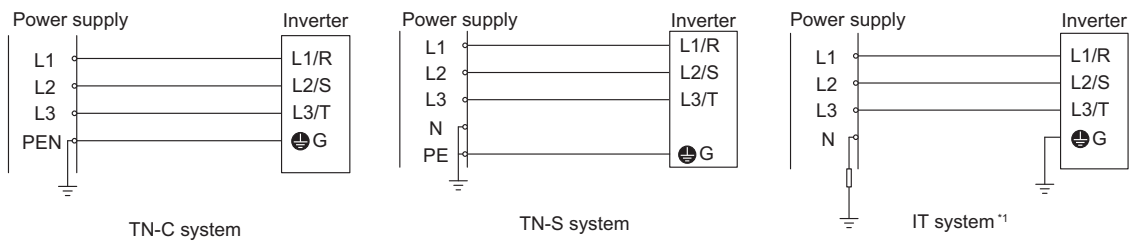

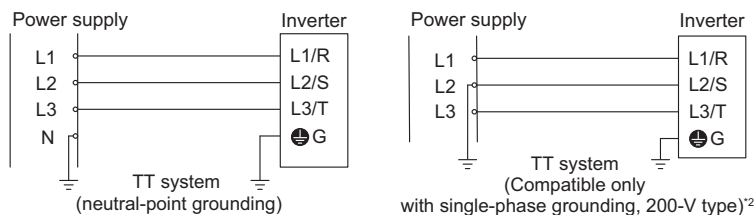

- \*1. The following IT system power supply is supported.

When the power supply system is not grounded at all	The insulation between the control interface and the main circuit of the inverter is the basic insulation. Accordingly, do not connect the SELV circuit directly from an external controller. (Connect using additional insulation.) Install a ground fault detector, and cut off the power supply within five seconds of a ground fault.
When the neutral point is grounded through an impedance	
When a single phase of the power supply is grounded through an impedance	Not supported.

- \*2. TT systems to which a single phase of a 400 V power supply is directly grounded are not supported.

- **A solid-state motor overload protection function (motor overload protection by electronic thermal relay) is mounted on each model. The protection level can be set at function codes F10 to F12.**

## Compliance with EMC Directive and Low Voltage Directive

(Manufacturer)

OMRON Corporation (Manufacturer)

Shiokoji Horikawa, Shimogyo-ku, Kyoto 600-8530 Japan

(Importer)

OMRON Europe B.V. (Importer in EU)

Wegalaan 67-69, 2132 JD Hoofddorp, The Netherlands

Cautions when exporting to Europe

- Not all OMRON products in Europe are imported through the above importer. When a different importer is exporting OMRON products to Europe, those importer is responsible to clarify their name and address as an importer and clearly indicate to the customer.

## Compliance with UKCA

The UK legislation require clear indication of the name and address of the manufacturer and importer is compulsory. The importer must clearly indicate the importer name and address to the customer.

(Manufacturer)

OMRON Corporation (Manufacturer)

Shiokoji Horikawa, Shimogyo-ku, Kyoto 600-8530 Japan

(UKCA Contact)

Omron Electronics LTD.  
Opal Drive, Fox Milne, MK15 0DG, Milton Keynes, United Kingdom

## Ecodesign Directive

We provide the VSD efficiency information regarding to motor regulation.  
For details, please visit the following website.  
<https://industrial.omron.eu/en/company-info/environmental/ecodesign-directive>



### 2-4-3 UL/cUL Standards Cautions

#### Caution

UL and cUL compliance is subject to conditions. Strictly observe the conditions listed in the instruction manual or user's manual.  
Not doing so may result in fire or accidents.



The warnings and instructions in this section summarizes the procedures necessary to ensure an inverter installation complies with Underwriters Laboratories guidelines.

Applicable Standards: UL61800-5-1, C22.2 No.274-17

- Use UL certified 60/75°C Cu wire only.
- Use Class1 wire for control circuits.
- This inverter is suitable for use on circuits where the delivering current is limited to 100 kA or less when protected by external Semiconductor Fuse with UL recognition. See next section for details of fuses.
- This inverter should be installed in an environment of pollution degree 2 and an overvoltage class III.
- Maximum surrounding air temperature is as below.

Inverter Type	HHD/HND	HD/ND
3G3M1-A2001, 3G3M1-A2002, 3G3M1-A2004, 3G3M1-A2007, 3G3M1-A2015 3G3M1-A2055, 3G3M1-A2075, 3G3M1-A2110, 3G3M1-A2150, 3G3M1-A2185	50°C	-
3G3M1-A4004, 3G3M1-A4007, 3G3M1-A4015 3G3M1-A4055, 3G3M1-A4075, 3G3M1-A4110, 3G3M1-A4150, 3G3M1-A4185, 3G3M1-A4220, 3G3M1-AB001, 3G3M1-AB002	50°C	40°C
3G3M1-AB037	50°C	-

Inverter Type	HHD	HND/HD/ND
3G3M1-A2022, 3G3M1-A2037 3G3M1-A4022, 3G3M1-A4030, 3G3M1-A4040 3G3M1-AB004, 3G3M1-AB007, 3G3M1-AB015, 3G3M1-AB022	50°C	40°C



- Set motor (electronic thermal) protection levels using parameters F10 to F12. (For details, refer to 5-3-3 *Motor Electronic Thermal Function* on page 5-20.)
- Integral solid state short circuit protection does not provide branch circuit protection. Branch circuit protection must be provided in accordance with the National Electric Code and any additional local codes.

The inverter does not have motor overheat protection built in.

## Main Circuit Terminal Block Screw Sizes, Tightening Torque and Wire Sizes

Power supply system	Standard applicable motor (kW)	Inverter Model	HHD/HD/HND/ND modes	Tightening torque lb-in (N · m)			Wire size AWG (mm <sup>2</sup> )							
				Main Terminal	Inverter's grounding	Control circuit auxiliary input	Main circuit copper wire						Ⓜ G	Control circuit auxiliary input
							L1/R, L2/S, L3/T			U, V, W				
							60°C Cu Wire	75°C Cu Wire	Remarks	60°C Cu Wire	75°C Cu Wire	Remarks		
Three-phase 200 V	0.1	3G3M1-A2001	HHD	10.6 (1.2)	15.9 (1.8)	-	14 (2.1)	14 (2.1)	*3	14 (2.1)	14 (2.1)	*3	14 (2.1)	-
	0.2	3G3M1-A2001	HND											
		3G3M1-A2002	HHD											
	0.4	3G3M1-A2002	HND											
		3G3M1-A2004	HHD											
	0.75	3G3M1-A2004	HND											
		3G3M1-A2007	HHD											
	1.1	3G3M1-A2007	HND											
	1.5	3G3M1-A2015	HHD											
	2.2	3G3M1-A2015	HND											
		3G3M1-A2022	HHD											
	3	3G3M1-A2022	HND											

Power supply system	Standard applicable motor (kW)	Inverter Model	HHD/HD/HND/ND modes	Tightening torque lb-in (N · m)			Wire size AWG (mm <sup>2</sup> )							
				Main Terminal	Inverter's grounding	Control circuit auxiliary input	Main circuit copper wire						Ⓜ G	Control circuit auxiliary input
							L1/R, L2/S, L3/T			U, V, W				
							60°C Cu Wire	75°C Cu Wire	Remarks	60°C Cu Wire	75°C Cu Wire	Remarks		
Three-phase 200 V	3.7	3G3M1-A2037	HHD	10.6 (1.2)	15.9 (1.8)	-	14 (2.1)	14 (2.1)	*3	12 (3.3)	12 (3.3)	*3	10 (5.3)	-
	5.5	3G3M1-A2037	HND	27 (3)	27 (3)		10 (5.3)	10 (5.3)		10 (5.3)	10 (5.3)		8 (8.4)	
		3G3M1-A2055	HHD				8 (8.4)	8 (8.4)						
	7.5	3G3M1-A2055	HND	51.3 (5.8)	51.3 (5.8)		6 (13.3)			8 (8.4)	8 (8.4)		6 (13.3)	
		3G3M1-A2075	HHD				4 (21.2)	6 (13.3)		6 (13.3)				
	11	3G3M1-A2075	HND	10.6 (1.2)			3 (26.7)	4 (21.2)		4 (21.2)	6 (13.3)			
		3G3M1-A2110	HHD				1 (42.4)	3 (26.7)		4 (21.2)	4 (21.2)			
	15	3G3M1-A2110	HND				1 (42.4)	3 (26.7)		3 (26.7)	4 (21.2)			
		3G3M1-A2150	HHD											
	18.5	3G3M1-A2150	HND				-	2 (33.6)	*2, *3	2 (33.6)	3 (26.7)			
		3G3M1-A2185	HHD											
	22	3G3M1-A2185	HND											

Power supply system	Standard applicable motor (kW)	Inverter Model	HHD/HD/HND/ND modes	Tightening torque lb-in (N · m)			Wire size AWG (mm <sup>2</sup> )							
				Main Terminal	Inverter's grounding	Control circuit auxiliary input	Main circuit copper wire						Ⓜ G	Control circuit auxiliary input
							L1/R, L2/S, L3/T			U, V, W				
							60°C Cu Wire	75°C Cu Wire	Remarks	60°C Cu Wire	75°C Cu Wire	Remarks	Inverter's grounding	
Three phase 400 V	0.4	3G3M1-A4004	HHD	10.6 (1.2)	15.9 (1.8)	-	14 (2.1)	14 (2.1)	*3	14 (2.1)	14 (2.1)	*3	14 (2.1)	-
	0.75	3G3M1-A4004	HD/HND											
		3G3M1-A4004	ND											
		3G3M1-A4007	HHD											
	1.1	3G3M1-A4007	HD/HND											
	1.5	3G3M1-A4007	ND											
		3G3M1-A4015	HHD											
	2.2	3G3M1-A4015	HD/HND											12 (3.3)
		3G3M1-A4015	ND											
		3G3M1-A4022	HHD											
	3	3G3M1-A4022	ND											
		3G3M1-A4022	HD/HND											
		3G3M1-A4030	HHD											
	4	3G3M1-A4030	ND/HD/HND											
		3G3M1-A4040	HHD											10 (5.3)
5.5	3G3M1-A4040	ND				12 (3.3)	12 (3.3)							
	3G3M1-A4040	HD/HND												
	3G3M1-A4055	HHD	27 (3)	27 (3)										

Power supply system	Standard applicable motor (kW)	Inverter Model	HHD/HD/HND/ND modes	Tightening torque lb-in (N · m)			Wire size AWG (mm <sup>2</sup> )								
				Main Terminal	Inverter's grounding	Control circuit auxiliary input	Main circuit copper wire						Ⓜ G	Control circuit auxiliary input	
							L1/R, L2/S, L3/T			U, V, W					
							60°C Cu Wire	75°C Cu Wire	Remarks	60°C Cu Wire	75°C Cu Wire	Remarks	Inverter's grounding		
Three-phase 400 V	7.5	3G3M1-A4055	HD/HND	27 (3)	27 (3)	-	10 (5.3)	10 (5.3)	*3	12 (3.3)	12 (3.3)	*3	10 (5.3)	-	
		3G3M1-A4075	HHD												
	11	3G3M1-A4055	ND				8 (8.4)	8 (8.4)		10 (5.3)	10 (5.3)		8 (8.4)		
		3G3M1-A4075	HD/HND												
		3G3M1-A4110	HHD	51.3 (5.8)	51.3 (5.8)										
	15	3G3M1-A4075	ND	27 (3)	27 (3)		6 (13.3)								
		3G3M1-A4110	HD/HND	51.3 (5.8)	51.3 (5.8)					8 (8.4)	8 (8.4)				
		3G3M1-A4150	HHD												
	18.5	3G3M1-A4110	ND					6 (13.3)		6 (13.3)			6 (13.3)		14 (2.1)* 1*2
		3G3M1-A4150	HD/HND												
		3G3M1-A4185	HHD			10.6 (1.2)					6 (13.3)				
	22	3G3M1-A4150	ND				4 (21.2)								
		3G3M1-A4185	HD/HND												
		3G3M1-A4220	HHD												
	30	3G3M1-A4185	ND				3 (26.7)	4 (21.2)		4 (21.2)					
3G3M1-A4220		HD/HND													
37	3G3M1-A4220	ND				2 (33.6)	3 (26.7)		3 (26.7)	4 (21.2)					

Power supply system	Standard applicable motor (kW)	Inverter Model	HHD/HND/HND/ND modes	Tightening torque lb-in (N · m)			Wire size AWG (mm <sup>2</sup> )								
				Main Terminal	Inverter's grounding	Control circuit auxiliary input	Main circuit copper wire						⊕ G	Control circuit auxiliary input	
							L1/R, L2/S, L3/T			U, V, W					
							60°C Cu Wire	75°C Cu Wire	Remarks	60°C Cu Wire	75°C Cu Wire	Remarks	Inverter's grounding		
Single-phase 200 V	0.1	3G3M1-AB001	HHD	7.1 (0.8)	10.6 (1.2)	-	14 (2.1)	14 (2.1)	*3	14 (2.1)	14 (2.1)	*3	14 (2.1)	-	
	0.2	3G3M1-AB001	HND												
		3G3M1-AB002	HHD												
	0.4	3G3M1-AB002	HND												
		3G3M1-AB004	HHD												
	0.75	3G3M1-AB004	HND											12 (3.3)	
		3G3M1-AB007	HHD												
	1.1	3G3M1-AB007	HND											10 (5.3)	
	1.5	3G3M1-AB015	HHD	10.6 (1.2)	15.9 (1.8)		12 (3.3)	12 (3.3)							
	2.2	3G3M1-AB015	HND												
		3G3M1-AB022	HHD												
	3	3G3M1-AB022	HND												
3.7	3G3M1-AB037	HHD	27 (3)	27 (3)		6 (13.3)	8 (8.4)			12 (3.3)	12 (3.3)		8 (8.4)		

\*1. Wires can be connected without any terminal treatment.

\*2. Only 75°C (167°F) Cu wiring can be used.

\*3. Shows common wiring sizes for UL Open Type and Enclosed Type. Please contact us separately if dedicated UL Open Type wiring sizes are required.

## Fuse Size

Power supply voltage	Standard applicable motor (kW)	Inverter model	HHD/HD/HND/N D mode	Semiconductor protection fuse product number, manufacturer: Mersen / Bussmann (Eaton)
Three-phase 200 V	0.1	3G3M1-A2001	HHD	PC30UD69V50□/170M3458
	0.2	3G3M1-A2001	HND	
		3G3M1-A2002	HHD	PC30UD69V50□/170M3458
	0.4	3G3M1-A2002	HND	
		3G3M1-A2004	HHD	PC30UD69V50□/170M3458
	0.75	3G3M1-A2004	HND	
		3G3M1-A2007	HHD	PC30UD69V50□/170M3460
	1.1	3G3M1-A2007	HND	
	1.5	3G3M1-A2015	HHD	PC30UD69V80□/170M3462
	2.2	3G3M1-A2015	HND	
		3G3M1-A2022	HHD	PC30UD69V125□/170M3462
	3	3G3M1-A2022	HND	
	3.7	3G3M1-A2037	HHD	PC30UD69V125□/170M3463
	5.5	3G3M1-A2037	HND	
		3G3M1-A2055	HHD	PC30UD69V160□/170M3464
	7.5	3G3M1-A2055	HND	
		3G3M1-A2075	HHD	PC30UD69V200□/170M3465
	11	3G3M1-A2075	HND	
		3G3M1-A2110	HHD	PC30UD69V200□/170M3465
	15	3G3M1-A2110	HND	
3G3M1-A2150		HHD	PC30UD69V250□/170M3466	
18.5	3G3M1-A2150	HND		
	3G3M1-A2185	HHD	PC30UD69V250□/170M3466	
22	3G3M1-A2185	HND		

Power supply voltage	Standard applicable motor (kW)	Inverter model	HHD/HD/HND/ND mode	Semiconductor protection fuse product number, manufacturer: Mersen / Busmann (Eaton)
Three-phase 400 V	0.4	3G3M1-A4004	HHD	PC30UD69V50□/170M3458
	0.75	3G3M1-A4004	HD/HND	
		3G3M1-A4004	ND	
		3G3M1-A4007	HHD	PC30UD69V50□/170M3458
	1.1	3G3M1-A4007	HD/HND	
	1.5	3G3M1-A4007	ND	PC30UD69V50□/170M3459
		3G3M1-A4015	HHD	
	2.2	3G3M1-A4015	HD/HND	PC30UD69V63□/170M3460
		3G3M1-A4015	ND	
		3G3M1-A4022	HHD	PC30UD69V63□/170M3460
	3	3G3M1-A4022	HD/HND	
		3G3M1-A4022	ND	PC30UD69V63□/170M3461
	3.7	3G3M1-A4040	HHD	
	5.5	3G3M1-A4040	HD/HND	PC30UD69V63□/170M3461
		3G3M1-A4040	ND	
		3G3M1-A4055	HHD	PC30UD69V100□/170M3462
	7.5	3G3M1-A4055	HD/HND	
			3G3M1-A4075	HHD
	11	3G3M1-A4075	ND	
			3G3M1-A4075	HD/HND
		3G3M1-A4110	HHD	
	15	3G3M1-A4075	ND	PC30UD69V100□/170M3462
			3G3M1-A4110	
		3G3M1-A4150	HHD	PC30UD69V160□/170M3464
	18.5	3G3M1-A4110	ND	
			3G3M1-A4150	HD/HND
		3G3M1-A4185	HHD	
22	3G3M1-A4150	ND	PC30UD69V160□/170M3464	
		3G3M1-A4185		HD/HND
	3G3M1-A4220	HHD	PC30UD69V200□/170M3465	
30	3G3M1-A4185	ND		
		3G3M1-A4220	HD/HND	PC30UD69V200□/170M3465
37	3G3M1-A4220	ND		

Power supply voltage	Standard applicable motor (kW)	Inverter model	HHD/HD/HND/N D mode	Semiconductor protection fuse product number, manufacturer: Mersen / Bussmann (Eaton)
Single-phase 200 V	0.1	3G3M1-AB001	HHD	PC30UD69V50□/170M3458
	0.2	3G3M1-AB001	HND	
		3G3M1-AB002	HHD	PC30UD69V50□/170M3458
	0.4	3G3M1-AB002	HND	PC30UD69V50□/170M3458
		3G3M1-AB004	HHD	
	0.75	3G3M1-AB004	HND	PC30UD69V50□/170M3460
		3G3M1-AB007	HHD	
	1.1	3G3M1-AB007	HND	PC30UD69V125□/170M3462
	1.5	3G3M1-AB015	HHD	
	2.2	3G3M1-AB015	HND	PC30UD69V125□/170M3463
		3G3M1-AB022	HHD	
	3	3G3M1-AB022	HND	PC30UD69V160□/170M3464
	3.7	3G3M1-AB037	HHD	



# 3

## Operation and Test Run

This section describes the part names and key operations of the Digital Operator, and the operation method of this product as well as the test run procedure.

---

<b>3-1</b>	<b>Operation of Operator</b> .....	<b>3-2</b>
3-1-1	Part Names and Descriptions.....	3-2
3-1-2	Key Operation Method .....	3-3
<b>3-2</b>	<b>Connecting Sysmac Studio</b> .....	<b>3-16</b>
<b>3-3</b>	<b>Flow of Test Run</b> .....	<b>3-17</b>
<b>3-4</b>	<b>Operation Items for Test Run</b> .....	<b>3-18</b>

## 3-1 Operation of Operator



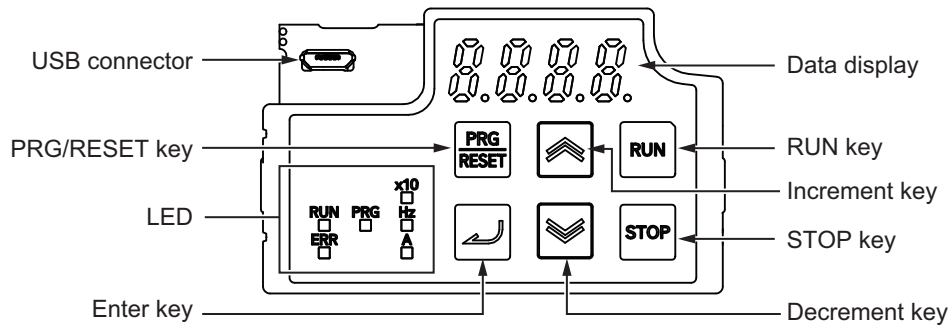

The Operator is a display operation panel for the 3G3M1 Series Inverter.

### 3-1-1 Part Names and Descriptions

The table below shows the name and function of each part of the Operator.



Display	Name	Description
	Error LED	Lights (red) when the inverter trips. For how to reset a trip error state, refer to <i>How to Reset a Trip State</i> on page 9-2.
	Program LED	Lights (green) when editable data (set value) is displayed on the data display.
	RUN LED	Lights (green) when the inverter is running (during output to the motor). Lights during deceleration after RUN command OFF. Goes out while the RUN command is ON at Frequency Reference 0 Hz as there is no output (excluding Zero Speed Control).
	Monitor LED (Hz)	Lights (green) when a frequency value is displayed on the data display.
	Monitor LED (A)	Lights (green) when a current value is displayed on the data display.
	x10 LED	This x10 LED lights (green) when the displayed data exceeds 9999. "Currently displayed data x 10" is the actual data.
	Data display	Displays (in red) various data such as a parameter value, frequency value, or set value.
	RUN command LED indicator LED (top right)	Lights (green) when the Run command is set to Digital Operator, and flashes (green) when the  key is enabled by the forced operator function.  (This indicates that the  key is enabled on the Digital Operator.)
	RUN key	Starts inverter operation. Note that this key is enabled when the RUN command is set to Digital Operator.
	STOP key	Stops the inverter (deceleration stop).

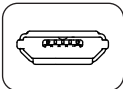

Display	Name	Description
	PRG/RESET key	In Operation mode: Pressing this key switches the mode to the Program mode. In Program mode: Pressing this key switches the mode to the Operation mode. In Alarm mode: Pressing this key after removing the cause of the alarm cancels the alarm and switches the mode to the Operation mode.
	Enter key	In Operation mode: Switches the monitor items (output frequency, output current, output voltage, etc.) for the operation status. In Program mode: Confirms the parameter display and data. In Alarm mode: Switches to the display of the alarm details information.
	Increment key	Increases the parameter number or the set data value.
	Decrement key	Decreases the parameter number or the set data value.
	USB connector	The connector (mini-B type) for connecting a computer. Used to connect to the automation software Sysmac Studio.

### 3-1-2 Key Operation Method

This section explains how to use the Digital Operator keys in a typical operation (when the Display Selections “Complete display”).

This operation will be the same even if you select a setting other than Complete display in the Operator Display Selection (E52), although the number of parameters that you will see on the display differs.

There are three operation modes displayed on the Digital Operator as shown in the following table.

Operation mode	Overview of each mode
Operation mode	This mode is automatically entered after the power is turned ON. In this mode, the set frequency/PID process commands and other information can be set, and RUN/STOP command operations are possible by the  /  keys. Operation status can be monitored in real time. When a light alarm occurs, the display switches to the light alarm display (L-AL).
Program mode	In this mode, parameter data can be set, and inverter status, various maintenance related information and other information can be checked.

Operation mode	Overview of each mode
Alarm mode	In this mode, alarm codes can be displayed when an alarm occurs, and various alarm related information can be checked. For details on the alarm codes, refer to 9-1 <i>Alarm Display and Remedies</i> on page 9-2.

Transition through these modes by the following key operations.

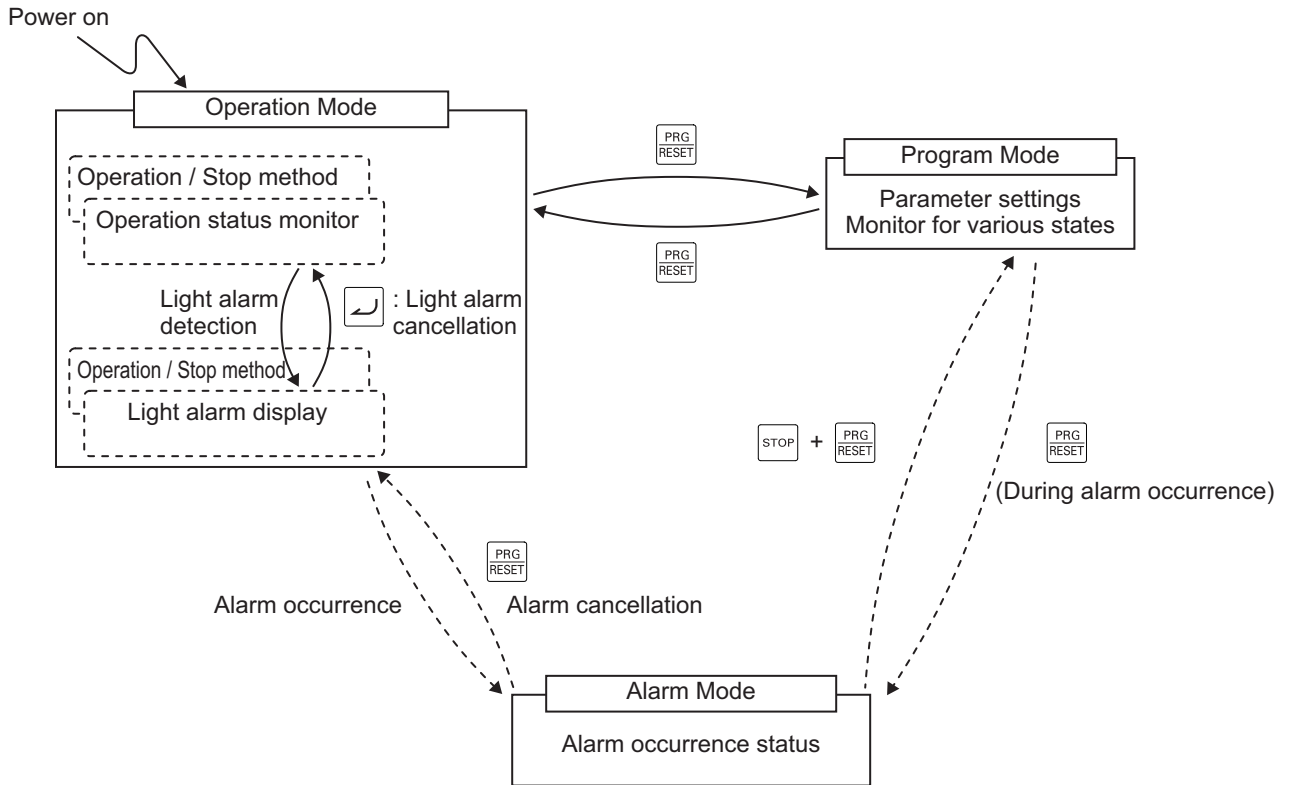

If the Operator is not operated for five minutes, the display automatically changes to the initial screen.

## Operation Mode

In the Operation mode, the following items can be monitored. After the power is turned ON, items set at parameter E43 are displayed. Monitor items can be switched by pressing the key.

If the Operator is not operated for five minutes, the display automatically changes to the initial screen selected by E43.

Monitor item	Unit LED display □ Not lit ■ Lit	Unit	Outline of display value	Function code E43 data
Speed Monitor	The following display formats can be selected by the function code E48.			0
Output frequency 1 (Before slip compensation)	■Hz □A	Hz	Display value = Output frequency (Hz)	(E48=0)
Output frequency 2 (After slip compensation)	■Hz □A	Hz	Display value = Output frequency (Hz)	(E48=1)
Set frequency	■Hz □A	Hz	Display value = Set frequency (Hz)	(E48=2)
Motor rotation speed	■Hz ■A	min <sup>-1</sup>	Display value = Output frequency (Hz) x 120/number of motor poles	(E48=3)
Load shaft speed	■Hz ■A	min <sup>-1</sup>	Display value = Output frequency (Hz) x E50/E39	(E48=4)
Feed speed	□Hz □A	m/min	Display value = Output frequency (Hz) x E50/E39	(E48=5)
Transport time for specified length	■Hz ■A	min	Display value = E50/(output frequency (Hz) x E39)	(E48=6)
Speed (%)	□Hz □A	%	Display value = Output frequency (Hz)/maximum frequency (Hz) x 100	(E48=7)
Output current	□Hz ■A	A	Inverter output current effective value	3
Input power	□Hz □A	kW	Inverter input power value	9
Calculated torque* <sup>1</sup>	□Hz □A	%	Generated motor torque (calculated value)	8
Output voltage* <sup>2</sup>	□Hz □A	V	Inverter output voltage effective value	4
Motor output	□Hz □A	%	Motor output (kW)	16
Load rate* <sup>3</sup>	□Hz □A	%	Load rate of motor is displayed as a percentage with the rated value taken to be 100%	15
PID process command* <sup>4*5</sup>	□Hz □A	-	The PID process command or PID feedback value is displayed after conversion to the physical quantity of the control target	10
PID feedback value* <sup>4*5</sup>	□Hz □A	-		12
PID deviation* <sup>4*5</sup>	□Hz □A	-	The deviation between the PID process command and PID feedback value is displayed after conversion to the physical quantity of the control target	29
PID output* <sup>4*6</sup>	□Hz □A	%	PID output is displayed as a percentage with 1st Maximum Output Frequency (F03) taken to be 100%	14
Timer* <sup>9</sup>	□Hz □A	s	Remaining time when timed operation is enabled	13

Monitor item	Unit LED display □ Not lit ■ Lit	Unit	Outline of display value	Function code E43 data
Analog input monitor*7	□Hz □A	-	The analog input of the inverter is displayed after conversion to the desired display	17
Current position*10	□Hz □A	-	The upper four digits and lower four digits of the current position user value (hexadecimal) are displayed alternately	21
Position error*10	□Hz □A	-	The upper four digits (signed) and lower four digits of the position deviation user value (hexadecimal) are displayed alternately	22
Target position*10	□Hz □A	-	The upper four digits (signed) and lower four digits of the target position user value (hexadecimal) are displayed alternately	28
Torque current*8	□Hz □A	%	The torque current command value or torque current calculated value is displayed	23
Magnetic flux command value*8	□Hz □A	%	The magnetic flux command value is displayed	24
Input watt-hour	□Hz □A	kWh	Display value = Input watt-hour (kWh)/100	25
Torque bias	□Hz □A	%	The torque bias value is displayed	30

\*1. 100% is the motor rated torque.

\*2. In the output voltage display, V is displayed at the lowermost digit of the LED monitor in place of unit symbol V (volt).

\*3. In the load rate display, the  icon is displayed at the lowermost digit of the LED monitor in place of %.

\*4. Displayed only when performing PID control (J01=1, 2 or 3).

\*5. The dot at the lowermost digit of the LED monitor flashes in the PID process command/PID output display.

\*6. The dot at the lowermost digit of the LED monitor lights in the PID feedback value display.

\*7. The analog input monitor is displayed only when the analog input monitor for display is set to enabled at E61 to E63 terminal function selection. The value converted by Input Terminal [AI1] Analog Input Adjustment Maximum Scale (C59), Input Terminal [AI1] Analog Input Adjustment Minimum Scale (C60), Input Terminal [AI2] Analog Input Adjustment Maximum Scale (AI1) (C65), Input Terminal [AI2] Analog Input Adjustment Minimum Scale (AI1) (C66), Input Terminal [AI2] Analog Input Adjustment Maximum Scale (AIV) (C71) and Input Terminal [AI2] Analog Input Adjustment Minimum Scale (AIV) (C72) is displayed.

\*8. 0 (zero) is displayed during V/f control.

\*9. Only (C21=3) is displayed when performing timed operation.

\*10. Displayed when the position control function is enabled.

Select the monitor information to be displayed on the Digital Operator LED when the inverter is stopped. When “0: Set frequency display” is set at Operator Display when Stopped Selection (E44), the set frequency is displayed, and when “1: Output frequency display” is set, the output frequency is displayed.

The display format is that selected at Operator Display Speed Monitor Item Selection (E48).

Parameter No.	Function name	Data	Default data	Unit
E44	Operator Display when Stopped Selection	0: Specified value 1: Output value	0	-

In 2nd control, each of A60 and A61 are used for E50 and E39.

Parameter No.	Function name	Data	Default data	Unit
E50	1st Frequency Conversion Coefficient	0.01 to 600.00	30.00	-
A60	2nd Speed Conversion Coefficient	0.00: Using E50 value 0.01 to 600.00	0.00	-
E39	Display Coefficient 1 for Transport Time / Auxiliary Display Coefficient 1 for Speed Monitor	0.000 to 9999	1.000	-
A61	2nd Display Coefficient for Transport time / Auxiliary Display Coefficient for Speed Monitor	0.000 to 9999	1.000	-

A filter can be applied to the display of the operation status monitor of the output frequency, output current and other information on the touch panel at Operator Display Filter (E42). When load fluctuations, for example, cause variance in the monitor values making them difficult to see, set a larger value.

Parameter No.	Function name	Data	Default data	Unit
E42	Operator Display Filter	0.0 to 5.0 s	0.5	-

## Program Mode

The Program mode has functions, for example, for setting and checking parameters, and for monitoring maintenance-related information and input/output (I/O) terminal information.

The digit (number) on the left end displayed on the Digital Operator LED indicates the menu No., and the remaining three digits indicate menu content.

From the second time onwards that the Program mode is entered, the menu that was active when the Program mode was previously exited is displayed.

Menu	LED display	Main function
Data setting	1F . .	F group parameters
	1E . .	E group parameters
	1E 1 .	E1 group parameters
	1C . .	C group parameters
	1P . .	P group parameters
	1H . .	H group parameters
	1H 1 .	H1 group parameters
	1H 3 .	H3 group parameters
	1H 4 .	H4 group parameters
	1A . .	A group parameters
	1b . .	b group parameters
	1r . .	r group parameters
	1J . .	J group parameters
	1J 1 .	J1 group parameters
	1d . .	d group parameters
	1d 1 .	d1 group parameters
	1d 2 .	d2 group parameters
	1y . .	y group parameters
Data check	2.rEP	Display/change of changed parameters
Operation monitor	3.oPE	Operation status display
I/O check	4.i.o	DIO, AIO status display
Maintenance	5.cHE	Maintenance information display
Alarm information	6.AL	Alarm information display
User preferences (user parameters)	0.FnI	Display/change of user preferences (user parameters)*1

Display/  
change of pa-  
rameters

\*1. When there are no parameters registered as user preferences, the menu item is hidden.



The menu to display can be selected at Operator Display Selection (E52). For details, refer to 5-1-1 *Display Selection* on page 5-3.

### ● Data setting

All parameters can be set at menu No. 1 “Data setting: 1F . . to 1Y . .” in the Program mode.

To set parameters at menu No. 1 “Data setting,” Operator Display Selection (E52) must be set to “0: Parameter data setting mode (menu 0 and menu 1)” or “2: Full menu mode.”

The following figure shows transition through “Data setting.”

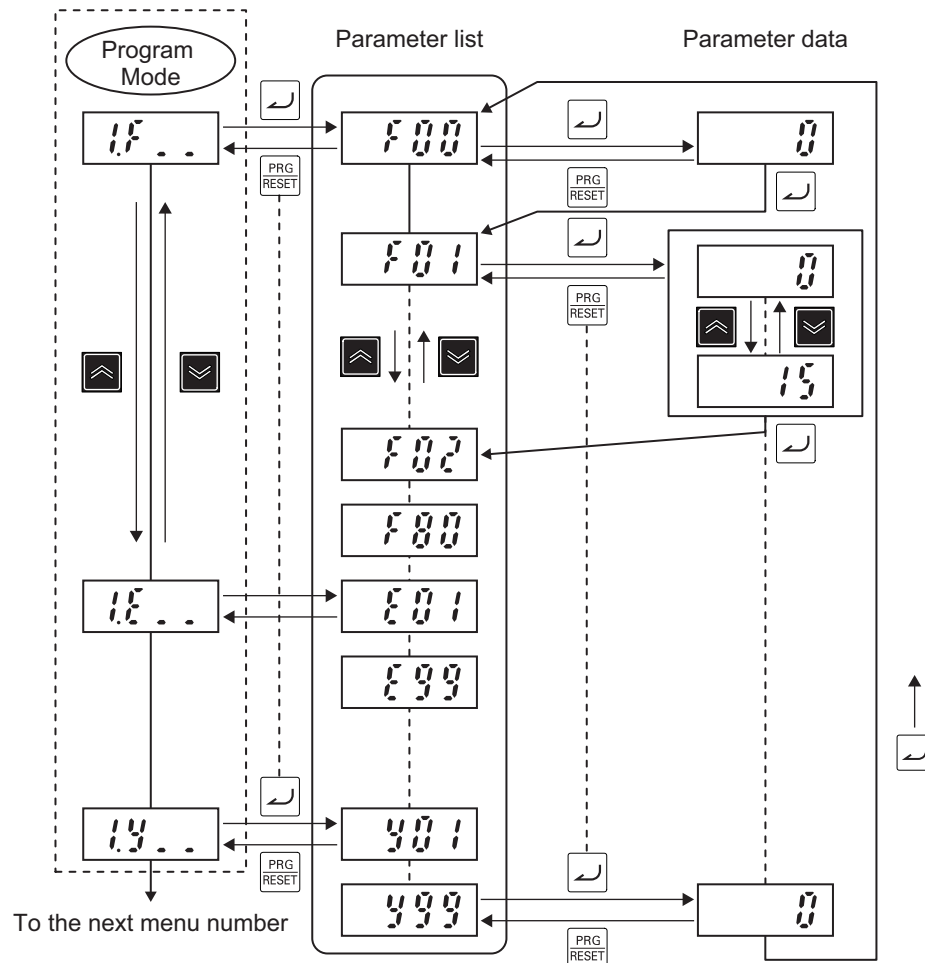

### ● Data check

After parameters have been changed, they can be checked at menu No. 2 “Data check: 2r E P” in the Program mode. Only parameters that have been changed from their factory default values are displayed on the LED monitor. The data of displayed parameters can also be referenced and changed. To monitor parameter data at menu No. 2 “Data check,” Operator Display Selection (E52) must be set to “1: Parameter data check mode (menu 2)” or “2: Full menu mode.”

Transitioning through “Data check” is the same as for Data setting.

### ● Operation monitor

Menu No. 3 “Operation monitor: 3.0 P E” is used to check the operation status in maintenance and test runs, for example.

For details on “Operation monitor” display items, refer to 7-1-1 *Operation Monitor* on page 7-3.

The following figure shows transition through “Operation monitor.”

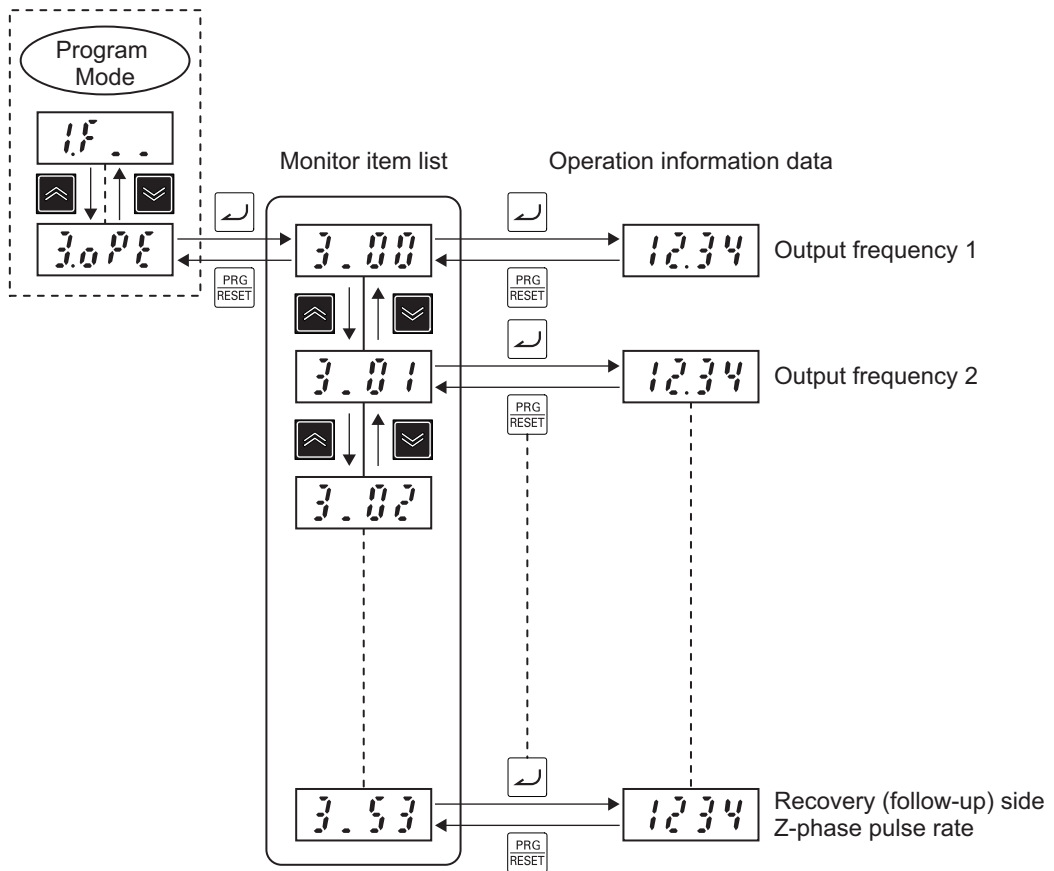

● **I/O check**

When menu No. 4 “I/O check: 4 . . 0” is used, the I/O signal status of external signals can be displayed on the LED monitor without the need to use a measuring instrument. External signals that can be displayed are digital I/O signals and analog I/O signals.

For details on “I/O check” display items, refer to 7-1-2 *I/O check* on page 7-11.

The following figure shows transition through “I/O check.”

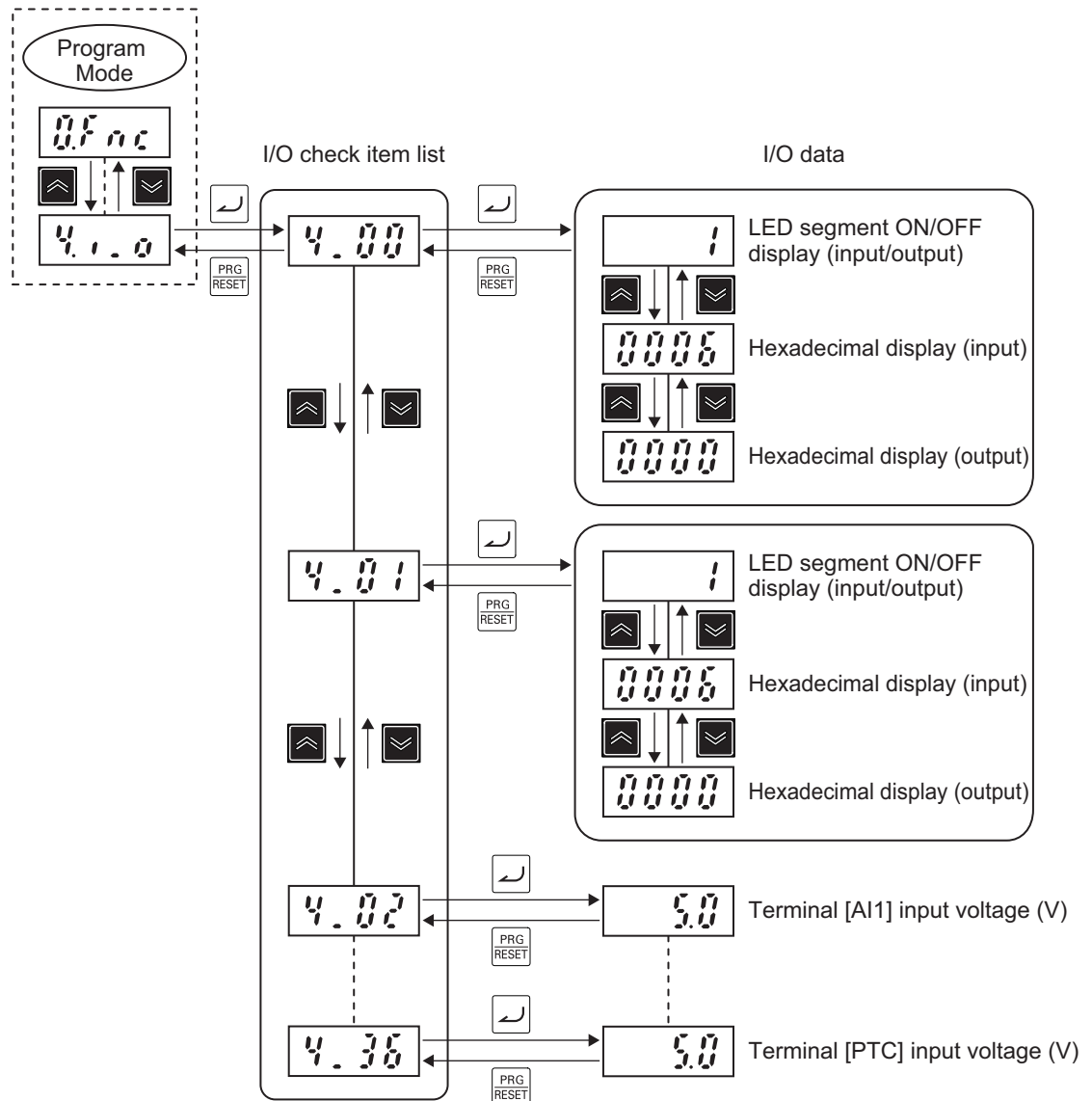

### ● Maintenance information

Menu No. 5 “Maintenance information:  $5.0$ ” displays information that is required when performing maintenance on the inverter.

For details on “Maintenance information” display items, refer to 7-1-3 *Maintenance Information* on page 7-13.

Transitioning through “Maintenance information” is the same as for “Operation monitor.”

### ● Alarm information

Menu No. 6 “Alarm information:  $6.0$ ” indicates by alarm code which protection functions were activated in the past six instances. Alarm information indicating the status of the inverter when each alarm occurred also can be displayed.

For details on “Alarm information” display items, refer to 7-1-4 *Alarm information* on page 7-18.

The following figure shows transition through “Alarm information.”

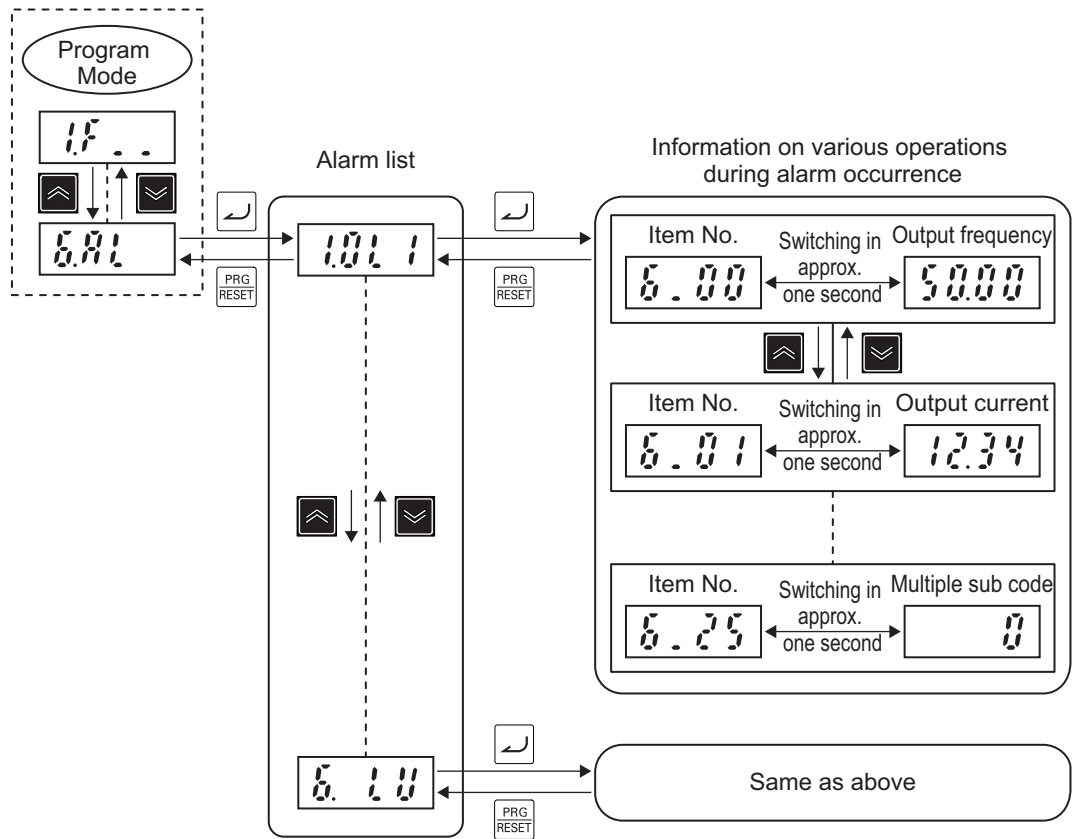

● **User preferences (user parameters)**

Only parameters registered as user preferences at menu No. 0 “User preferences (user parameters)” can be displayed, and the data of these parameters can be set.

To display parameters at menu No. 0 “User preferences (user parameters),” Operator Display Selection (E52) must be set to “0: Parameter data setting mode (menu 0 and menu 1)” or “2: Full menu mode.”

For details on registering user preferences (user parameters), refer to *7-7-6 User Parameter Setting Function* on page 7-80.

The following figure shows transition through “User preferences (user parameters).”

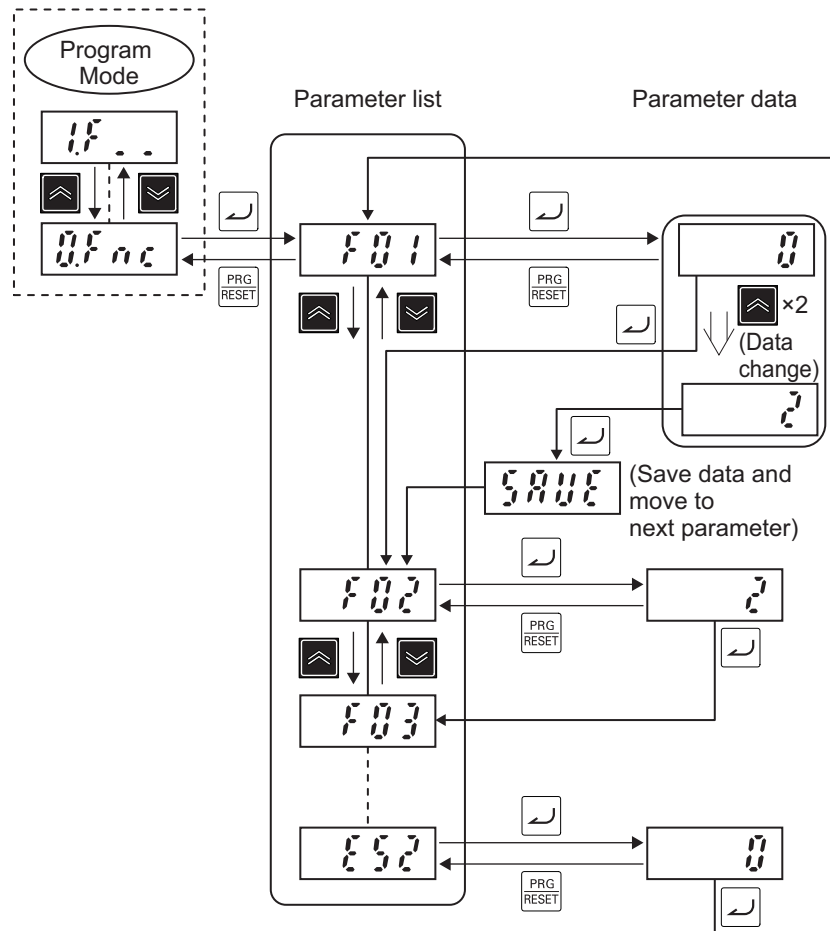

## Alarm Mode

When a protection function is activated and an alarm is generated, the inverter automatically transitions to the Alarm mode, and the alarm code of the alarm that occurred is displayed on the LED monitor.



To clear the alarm, remove the cause of the alarm and then press the key. The inverter returns to the Operation mode. Clearing of alarms by the key is enabled only when an alarm code is displayed.

In addition to the current alarm code, alarm codes for the past five instances can be displayed. Past alarm codes are displayed by pressing the / keys with the current alarm code displayed.

When the key is pressed with an alarm code displayed, various operation information such as the output frequency and output current at the time the alarm occurred can be checked. For the various operation information, the item No. and data are displayed alternately.

The multiple sets of various operation information can be switched by the / keys. Details of operation information are the same as menu No. 6 "Alarm information" in the Program mode. Refer to 7-1-4 *Alarm information* on page 7-18.

When operation information is displayed, the display returns to the alarm code by pressing the  key.

The mode transitions to the Program mode and parameter data can be corrected by simultaneously pressing the “ key +  key” with an alarm displayed.

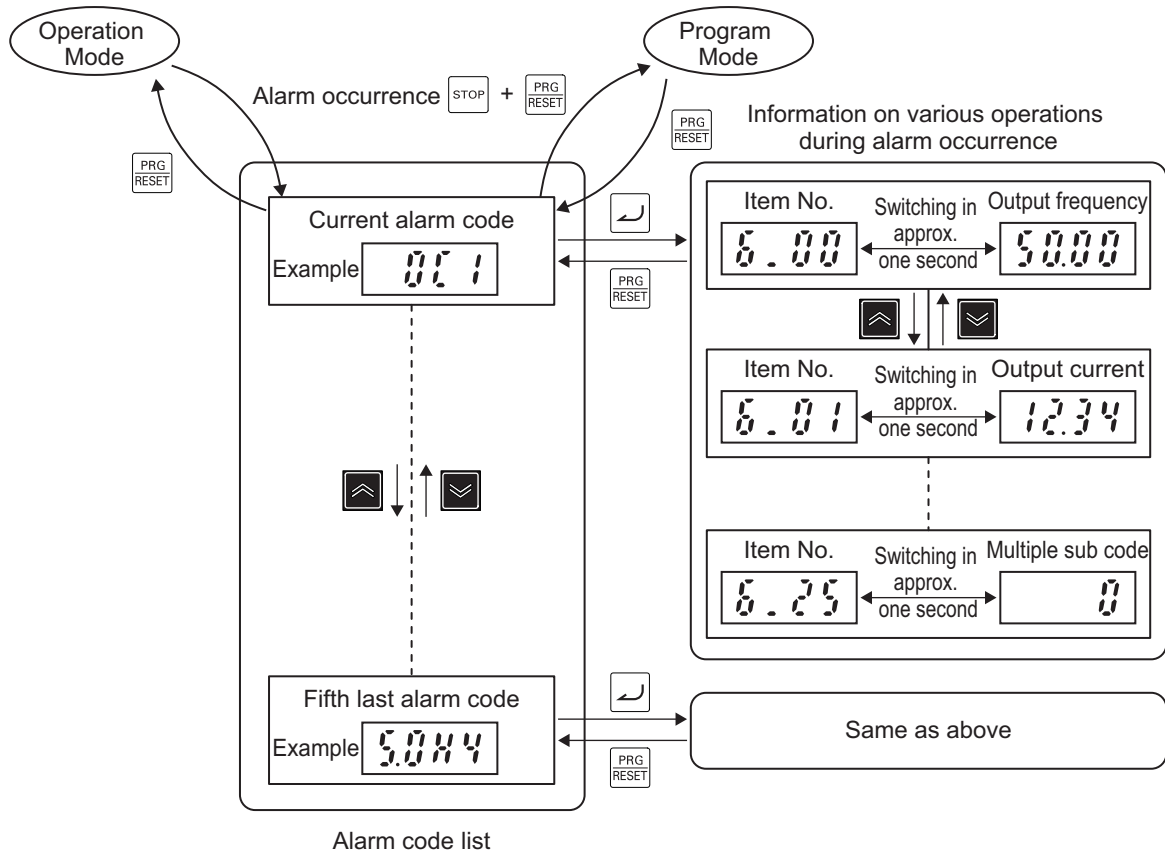

## Parameter Initialization



The set values of parameters can be initialized and returned to their factory default settings. The fault monitor can also be cleared.

For details on parameter initialization, refer to *5-1-2 Data Initialization* on page 5-4.

The following figure shows the steps of parameter initialization.

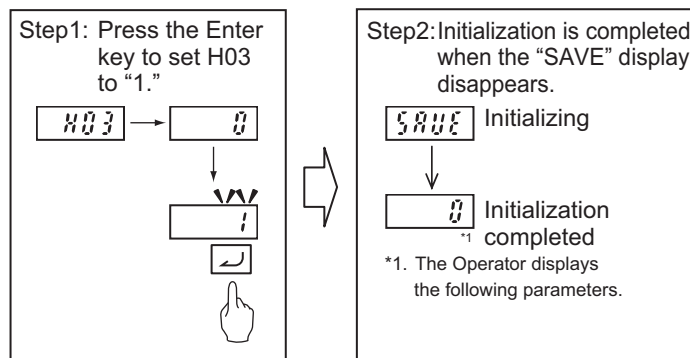
Initialization is executed when “1: Initialize all parameters” is set at Data Initialization (H03).



To change the data of parameter H03, the “STOP key +  /  keys” must be pressed simultaneously.

## Mock Alarm

Occurrence of an alarm can be simulated to check external sequences during inverter setup. By setting 1 to Mock Alarm (H45), mock alarm display “Err” is displayed on the LED monitor and the alarm signal “AL” is turned ON. Output terminal can be checked by allocating “99: AL (Alarm signal)” to output terminal function selection (E20 to E21, E27).

To change the data of H45, the “STOP key +  key” must be pressed simultaneously. After a mock alarm is generated, the data of H45 automatically returns to 0 and the alarm can be reset.

Also when clearing the alarm data of the mock alarm after setup is ended, H03 is used in the same way as when clearing the alarm data of alarms that occur during regular operation (to change the data of H03, the “STOP key +  key” must be pressed simultaneously). After alarm data is cleared, the data of H03 automatically returns to 0.

Parameter No.	Function name	Data	Default data	Unit
H45	Mock Alarm	0: Disable 1: Enable (Generate mock alarm)	0	-

## 3-2 Connecting Sysmac Studio

---

Inverter parameters can be edited, data can be monitored and other operations are possible in the automation software Sysmac Studio.

This section describes how to connect the inverter to Sysmac Studio.

1. Connect the USB cable to the USB connector, and connect the inverter to the PC.
2. Start up Sysmac Studio, and select new project.  
Select “Drive” at Category, specify the inverter to connect to the device, and click “Create.”
3. Right-click on the target inverter in the tree, and select “Communication Settings.”  
Check that “Connect directly by USB” is set, and select the USB port to which the cable is connected at Select Port.
4. Right-click on the target inverter in the tree, and select “Online.”

For details on how to connect Sysmac Studio and its function, refer to *Related Manuals* on page 30.



## 3-3 Flow of Test Run

Perform a test run of the inverter according to the following flow.

Item	Description	Reference
Installation	Install the inverter according to the installation conditions.	2-1-1 <i>Inverter Installation</i> on page 2-2
↓		
Wiring and connections	Connect the inverter to the power supply and peripheral equipment.	2-3 <i>Wiring</i> on page 2-10
↓		
Power-on	Check the points mentioned in the next page before turning the power supply ON.	3-4 <i>Operation Items for Test Run</i> on page 3-18
↓		
Display status checks	Check that no error is occurring on the inverter.	Section 9 <i>Troubleshooting</i> on page 9-1
↓		
Parameter initialization	Initialize inverter parameters.	5-1 <i>Display and Initialization</i> on page 5-3
↓		
Parameter setting	Set the parameters required for the test run.	5-3 <i>Motor Parameter Settings</i> on page 5-19 5-4 <i>RUN command</i> on page 5-25
↓		
No-load run	Run the motor in a no-load state via Digital Operator.	3-1 <i>Operation of Operator</i> on page 3-2
↓		
Load run	Operate the inverter via Digital Operator with the mechanical system connected.	3-1 <i>Operation of Operator</i> on page 3-2
↓		
Operation	Basic settings (operation by the basic settings required to operate and stop the inverter)	Section 5 <i>Basic Settings</i> on page 5-1
	Vector control (operation using vector control and other functions)	Section 6 <i>Vector Control and Applied Functions</i> on page 6-1

## 3-4 Operation Items for Test Run

The following describes the operation items for the test run.

### Installation

Check that the inverter meets the installation conditions.

For details on installing the inverter, refer to *2-1 Installation* on page 2-2.

### Wiring and Connections

Select peripheral equipment according to the specifications and wire the cables securely.

For details on wiring the inverter, refer to *2-3 Wiring* on page 2-10.

### Power-on

#### ● Points to be checked before turning ON the power

Check that the power supply voltage is appropriate and that the power supply input terminals (L1/R, L2/S, L3/T) are securely wired.

The rated input voltage of the 3G3M1 Series Inverter is as follows.

Model	Power supply voltage
3G3M1-A2□	Three-phase 200 to 240 VAC
3G3M1-A4□	Three-phase 380 to 480 VAC
3G3M1-AB□	Single-phase 200 to 240 VAC

Check that the motor is securely connected to the motor output terminals (W, V, U).

Check that the controller is securely wired to the control circuit terminals. In addition, turn OFF all control terminals.

Set the motor in a no-load state (not connected to the mechanical system).

#### ● Power-on

If no problem is found in the above checks, turn the power supply ON.

### Display Status Checks

If no problem is found at power-on, the display status will be as follows.

Name	Display status
RUN LED	Not lit (Lit during RUN)
ERR LED	Not lit
PRG LED	Not lit
x10 LED	Not lit
Hz LED	Lit
A LED	Not lit

Name	Display status
Data display	During a stop, the set frequency (flashes), and during a run, the output frequency (lit)
RUN command LED indicator	Lit when Operator is selected at F02

If any problem is found, the display status will be as follows.

Refer to *Section 9 Troubleshooting* on page 9-1 for countermeasures.

Name	Display status
RUN LED	Not lit
ERR LED	Lit
PRG LED	Not lit
x10 LED	Not lit
Hz LED	Lit
A LED	Not lit
Data display	Fault code (high-speed flashing)
RUN command LED indicator	Lit when Operator is selected at F02

## Parameter Initialization

The set values of parameters can be initialized and returned to their factory default settings. The fault monitor can also be cleared.

The following figure shows the steps of parameter initialization.

Initialization is executed when “1: Initialize all parameters” is set at Data Initialization (H03).

For details on parameter initialization, refer to *5-1 Display and Initialization* on page 5-3.

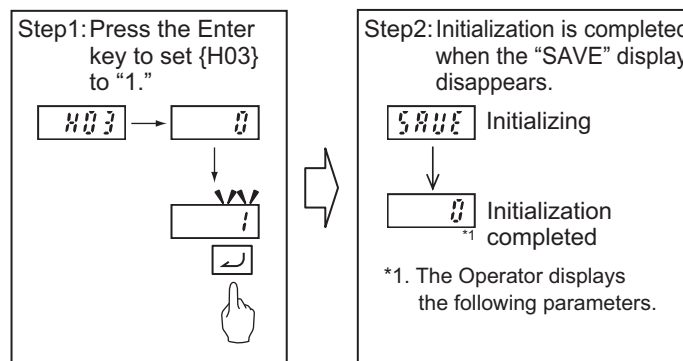

To change the data of parameter H03, the “STOP key + / keys” must be pressed simultaneously.

## Parameter Setting

To operate the inverter, two commands are required: the RUN command and the frequency reference. Set 1st RUN Command Selection (F02) and 1st Frequency Reference Selection (F01). For the test run, set 1st Frequency Reference Selection (F01) to “0” and 1st RUN Command Selection (F02) to “2” so as to operate the inverter via the Digital Operator.

Next, set the 1st Motor Pole Number (P01) and 1st Motor Capacity (P02) for of applicable motor.





These values will be used as the reference values for the automatic torque boost, motor protection and torque limit functions. Refer to *5-3-1 Induction Motor Basic Settings* on page 5-19, *5-3-2 Base*

*Frequency and Maximum Frequency of Motor* on page 5-19 and *6-1-2 Basic Motor Parameter Settings* on page 6-4.

Execute auto-tuning. (Refer to *6-8-1 Motor Off-line Auto-tuning* on page 6-65.)

Then set the rated current value of the motor at 1st Motor Electronic Thermal Level (F11).

Set the value correctly according to the motor in use.



Parameter No.	Function name	Set value	Default data	Unit
F01	1st Frequency Reference Selection	0 to 15 0: Operator (  and  keys) 1: Analog voltage input (terminal AI1) 2: Analog current input (terminal AI2 (All)) 3: Analog voltage input (terminal AI1) + analog current input (terminal AI2 (All)) 5: Analog voltage input (terminal AI2 (AIV)) 7: UP/DOWN control 8: Digital Operator (  and  keys) (balance-less/umpless switching available) 10: Pattern operation 12: Pulse train input 13: Calculation result 14: RS-485 communication 15: Fieldbus (Reserved)	0	-
F02	1st RUN Command Selection	0: Operator (Direction of rotation input: terminal block) 1: External signal (Digital input) 2: Operator (Forward rotation) 3: Operator (Reverse rotation) 4: RS-485 communication 5: Fieldbus (Reserved)	2	-
P01	1st Motor Pole Number	2 to 128 poles	4	Pole
P02	1st Motor Capacity	0.01 to 1000 kW	Dependent on capacity	kW
F11	1st Motor Electronic Thermal Level	0.00 ; 0.01 to 118.8 0.00 : Disable 0.01 to 118.8 A  * Setting range from 1%(HHD) to 135%(ND) of the rated inverter current.	Dependent on capacity	A

## No-Load Run



In a motor no-load state (not connected to the mechanical system), rotate the motor via the Digital Operator.







### ● Forward/reverse rotation via Digital Operator

Follow the steps below to rotate the motor in the forward or reverse direction via Digital Operator.

1. Set 1st Frequency Reference Selection (F01).  
Set "0: Operator" at 1st Frequency Reference Selection (F01).
2. Set 1st RUN Command Selection (F02).  
Set forward rotation (2: Touch panel operation (forward)) or reverse rotation (3: Touch panel operation (reverse)) at 1st RUN Command Selection (F02).
3. Set the output frequency.  
Set the set frequency by the  /  keys with the set frequency "0.00" displayed flashing. Initially, it is recommended to set a low speed of about 5 Hz for safety.
4. Press the  key.  
The motor starts rotating with the RUN LED lit.
5. Check that there is no problem with the output frequency, motor rotation direction or inverter operation displayed on the Digital Operator.  
For the rotation direction of motor, refer to rotation direction (monitor mode: 3\_06).

Parameter No.	Function name	Set value	Default data	Unit
C99	1st Frequency Reference/1st Multi-step Frequency Reference 0	0.0 to 590.00 Hz	0	Hz
F02	1st RUN Command Selection	0: Operator (Direction of rotation input: terminal block) 1: External signal (Digital input) 2: Operator (Forward rotation) 3: Operator (Reverse rotation) 4: RS-485 communication 5: Fieldbus (Reserved)	2	-

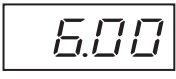
Monitor mode	Name	Data
3_00	Output frequency 1	0.00 to 99.99 to 590.0 [Hz]
3_06	Rotation direction	 : During forward rotation  : During reverse rotation  : During stop

Key operation	Data display example	Description
		When the output frequency "0.00" is not displayed, press the  key to display the output frequency.
		Press the  key. The monitor value of the frequency reference is displayed on the data display.

### ● Stopping the motor

After rotating the motor with no-load in the forward or reverse direction via the Digital Operator, press the  key. The motor stops rotating.

## Load Run

---

If no problem is found during a no-load run, connect the mechanical system and run the inverter with a load via the Digital Operator.

### ● Connecting the mechanical system

Before connecting the mechanical system, make sure that the motor has stopped completely. Then, connect the mechanical system to the motor securely to prevent the mounting screws from loosening.

### ● Operation via Digital Operator

In case of unexpected abnormal inverter operation, be prepared to press the  key on the Digital Operator.

In the same way as during a no-load run, operate the machine at low speed and then decelerate to stop via the Digital Operator.

### ● RUN mode checks

After checking that the machine moves in the correct direction and smoothly at low speed, set a larger output frequency.

Check that there is no mechanical vibration and noise by altering the output frequency setting and forward rotation (2: Touch panel operation (forward)) and reverse rotation (3: Touch panel operation (reverse)) at 1st RUN Command Selection (F02).

Also, check the current, load rate and voltage values at Output current effective value (monitor mode: 3\_02), Motor Electronic Thermal (monitor mode: 5\_62) and Main Circuit DC Voltage (monitor mode: 5\_01).

Check that the output current is up to 150% of the motor rated current.

Also, check that the electronic thermal load rate is sufficiently low to reach 100%.

Check that the DC voltage for 200-V class and for 400-V class is sufficiently low to reach 390 VDC and 780 VDC, respectively.

## Operation

---

To operate the inverter by only basic parameters, refer to *Section 5 Basic Settings* on page 5-1.

To use applied functions such as sensorless vector control, V/f control with speed feedback, torque control, and simple position control, in addition to *Section 5 Basic Settings* on page 5-1, refer to *Section 6 Vector Control and Applied Functions* on page 6-1.

# 4

## Parameter List

---

<b>4-1</b>	<b>List of Monitors by Group .....</b>	<b>4-2</b>
4-1-1	Parameter M (Monitor 1) .....	4-2
4-1-2	Parameter W (Monitor 2) .....	4-30
4-1-3	Parameter z (Alarm Information 1) .....	4-40
4-1-4	Parameter X (Alarm Information 2) .....	4-50
<b>4-2</b>	<b>List of Parameters by Group .....</b>	<b>4-77</b>
4-2-1	Parameter F (Basic Functions).....	4-77
4-2-2	Parameter E (Terminal Functions).....	4-84
4-2-3	Parameter C (Frequency Reference and Analog Input Functions) .....	4-99
4-2-4	Parameter P (Motor 1 Parameter).....	4-112
4-2-5	Parameter H (High Level Functions) .....	4-116
4-2-6	Parameter A (Motor 2 Parameter).....	4-135
4-2-7	Parameter b (Speed Control 3) .....	4-141
4-2-8	Parameter r (Speed Control 4) .....	4-142
4-2-9	Parameter J (Applied Functions 1).....	4-143
4-2-10	Parameter d (Applied Functions 2).....	4-148
4-2-11	Parameter y (RS-485 Communication Settings) .....	4-159
4-2-12	Parameter S (Via RS-485) .....	4-161

## 4-1 List of Monitors by Group

When monitoring on the Digital Operator, refer to 7-1 *Status Monitors* on page 7-3.

The following table shows the parameters that allow monitoring of Sysmac Studio.

Enabled and disabled states for each control mode within the data range of the parameters are indicated by the icon.

Symbol	Control method (F42/A14)
<input type="checkbox"/> V/f	0: IM V/f control
<input type="checkbox"/> DTV	1: IM Dynamic torque vector control
<input type="checkbox"/> PG V/f	3: IM V/f control with speed sensor
<input type="checkbox"/> PG DTV	4: IM Dynamic torque vector control with speed sensor
<input type="checkbox"/> SLV	5: IM Vector control without speed sensor
<input type="checkbox"/> PGV	6: IM Vector control with speed sensor
<input type="checkbox"/> PM SLV	15: PM Vector control without speed and pole position sensor
<input type="checkbox"/> PM PGV	16: PM Vector control with speed and pole position sensor

V/f : Enabled  V/f : Disabled

### 4-1-1 Parameter M (Monitor 1)

Parameter No.	Function name	Monitor or data range	Default data	Setting during RUN	Unit
M01	Frequency Reference at Final	<input type="checkbox"/> V/f <input type="checkbox"/> DTV <input type="checkbox"/> PG V/f <input type="checkbox"/> PG DTV <input type="checkbox"/> SLV <input type="checkbox"/> PGV <input type="checkbox"/> PM SLV <input type="checkbox"/> PM PGV -32768 to 32767 +20000 or -20000 = maximum output frequency	0	-	-
M02	Torque Reference Monitor at Last	<input checked="" type="checkbox"/> V/f <input checked="" type="checkbox"/> DTV <input checked="" type="checkbox"/> PG V/f <input checked="" type="checkbox"/> PG DTV <input type="checkbox"/> SLV <input type="checkbox"/> PGV <input type="checkbox"/> PM SLV <input type="checkbox"/> PM PGV -327.68 to 327.67	0	-	%
M03	Torque Current Command at Final	<input checked="" type="checkbox"/> V/f <input checked="" type="checkbox"/> DTV <input checked="" type="checkbox"/> PG V/f <input checked="" type="checkbox"/> PG DTV <input type="checkbox"/> SLV <input type="checkbox"/> PGV <input type="checkbox"/> PM SLV <input type="checkbox"/> PM PGV -327.68 to 327.67	0	-	%
M04	Magnetic Flux Command Value	<input checked="" type="checkbox"/> V/f <input checked="" type="checkbox"/> DTV <input checked="" type="checkbox"/> PG V/f <input checked="" type="checkbox"/> PG DTV <input type="checkbox"/> SLV <input type="checkbox"/> PGV <input type="checkbox"/> PM SLV <input type="checkbox"/> PM PGV -327.68 to 327.67	0	-	%
M05	Frequency Reference at Final	<input type="checkbox"/> V/f <input type="checkbox"/> DTV <input type="checkbox"/> PG V/f <input type="checkbox"/> PG DTV <input type="checkbox"/> SLV <input type="checkbox"/> PGV <input type="checkbox"/> PM SLV <input type="checkbox"/> PM PGV 0.00 to 655.35	0	-	Hz



Parameter No.	Function name	Monitor or data range	Default data	Setting during RUN	Unit
M06	Output Frequency 1 without Slip Compensation	<div style="display: flex; justify-content: space-between; border-bottom: 1px solid black; padding-bottom: 2px;"> <span>V/f</span> <span>DTV</span> <span>PG V/f</span> <span>PG DTV</span> </div> <div style="display: flex; justify-content: space-between; border-bottom: 1px solid black; padding-bottom: 2px;"> <span>SLV</span> <span>PGV</span> <span>PM SLV</span> <span>PM PGV</span> </div> -32768 to 32767 +20000 or -20000 = maximum output frequency	0	-	-
M07	Torque Value	<div style="display: flex; justify-content: space-between; border-bottom: 1px solid black; padding-bottom: 2px;"> <span>V/f</span> <span>DTV</span> <span>PG V/f</span> <span>PG DTV</span> </div> <div style="display: flex; justify-content: space-between; border-bottom: 1px solid black; padding-bottom: 2px;"> <span>SLV</span> <span>PGV</span> <span>PM SLV</span> <span>PM PGV</span> </div> -327.68 to 327.67	0	-	%
M08	Torque Current Value	<div style="display: flex; justify-content: space-between; border-bottom: 1px solid black; padding-bottom: 2px;"> <span>V/f</span> <span>DTV</span> <span>PG V/f</span> <span>PG DTV</span> </div> <div style="display: flex; justify-content: space-between; border-bottom: 1px solid black; padding-bottom: 2px;"> <span>SLV</span> <span>PGV</span> <span>PM SLV</span> <span>PM PGV</span> </div> -327.68 to 327.67	0	-	%
M09	Output Frequency without Slip Compensation	<div style="display: flex; justify-content: space-between; border-bottom: 1px solid black; padding-bottom: 2px;"> <span>V/f</span> <span>DTV</span> <span>PG V/f</span> <span>PG DTV</span> </div> <div style="display: flex; justify-content: space-between; border-bottom: 1px solid black; padding-bottom: 2px;"> <span>SLV</span> <span>PGV</span> <span>PM SLV</span> <span>PM PGV</span> </div> 0.00 to 655.35 Hz	0	-	Hz
M10	Input Power	<div style="display: flex; justify-content: space-between; border-bottom: 1px solid black; padding-bottom: 2px;"> <span>V/f</span> <span>DTV</span> <span>PG V/f</span> <span>PG DTV</span> </div> <div style="display: flex; justify-content: space-between; border-bottom: 1px solid black; padding-bottom: 2px;"> <span>SLV</span> <span>PGV</span> <span>PM SLV</span> <span>PM PGV</span> </div> 0.00 to 399.99	0	-	%
M11	Output Current Monitor	<div style="display: flex; justify-content: space-between; border-bottom: 1px solid black; padding-bottom: 2px;"> <span>V/f</span> <span>DTV</span> <span>PG V/f</span> <span>PG DTV</span> </div> <div style="display: flex; justify-content: space-between; border-bottom: 1px solid black; padding-bottom: 2px;"> <span>SLV</span> <span>PGV</span> <span>PM SLV</span> <span>PM PGV</span> </div> 0.00 to 399.99 %	0	-	%
M12	Output Voltage Monitor	<div style="display: flex; justify-content: space-between; border-bottom: 1px solid black; padding-bottom: 2px;"> <span>V/f</span> <span>PG V/f</span> <span>PG DTV</span> <span>SLV</span> </div> <div style="display: flex; justify-content: space-between; border-bottom: 1px solid black; padding-bottom: 2px;"> <span>PGV</span> <span>PM SLV</span> <span>PM PGV</span> </div> 0.0 to 1000.0 V	0	-	V
M13	Operation Command at Final	<div style="display: flex; justify-content: space-between; border-bottom: 1px solid black; padding-bottom: 2px;"> <span>V/f</span> <span>DTV</span> <span>PG V/f</span> <span>PG DTV</span> </div> <div style="display: flex; justify-content: space-between; border-bottom: 1px solid black; padding-bottom: 2px;"> <span>SLV</span> <span>PGV</span> <span>PM SLV</span> <span>PM PGV</span> </div> Bit15: RST Bit14: DI7 Bit13: DI6 Bit12: - Bit11: EN Bit10: - Bit9: - Bit8: - Bit7: - Bit6: DI5 Bit5: DI4 Bit4: DI3 Bit3: DI2 Bit2: DI1 Bit1: REV Bit0: FWD	0	-	-

Parameter No.	Function name	Monitor or data range	Default data	Setting during RUN	Unit
M14	Operation Status 1 Monitor	<p>V/f   DTV   PG V/f   PG DTV</p> <p>SLV   PGV   PM SLV   PM PGV</p> <p>Bit15: BUSY (During function code data writing)                      Bit14: -                      Bit13: -                      Bit12: RL (Communications effective)                      Bit11: ALM (Alarm relay)                      Bit10: DEC (During deceleration)                      Bit9: ACC (During acceleration)                      Bit8: IL (During current limiting)                      Bit7: VL (During voltage limiting)                      Bit6: TL (Torque limiting)                      Bit5: NUV (Main circuit DC voltage established)                      Bit4: BRK (During braking)                      Bit3: INT (Inverter shut down)                      Bit2: EXT (During DC braking or during pre-exciting)                      Bit1: REV (During reverse operation)                      Bit0: FWD (During forward operation)</p>	0	-	-
M15	Output Terminal Monitor	<p>V/f   DTV   PG V/f   PG DTV</p> <p>SLV   PGV   PM SLV   PM PGV</p> <p>Bit15: -                      Bit14: -                      Bit13: -                      Bit12: -                      Bit11: -                      Bit10: -                      Bit9: -                      Bit8: RO                      Bit7: -                      Bit6: -                      Bit5: -                      Bit4: -                      Bit3: -                      Bit2: -                      Bit1: DO2                      Bit0: DO1</p>	0	-	-

Parameter No.	Function name	Monitor or data range	Default data	Setting during RUN	Unit
M16	Latest Alarm Contents	<div style="display: flex; justify-content: space-between; border: 1px solid black; padding: 2px;"> <span>V/f</span> <span>DTV</span> <span>PG V/f</span> <span>PG DTV</span> </div> <div style="display: flex; justify-content: space-between; border: 1px solid black; padding: 2px; margin-top: 5px;"> <span>SLV</span> <span>PGV</span> <span>PM SLV</span> <span>PM PGV</span> </div> <p>0 (00 Hex): No alarm  1 (01 Hex): OC1 Overcurrent protection (during acceleration)  2 (02 Hex): OC2 Overcurrent protection (during deceleration)  3 (03 Hex): OC3 Overcurrent protection (during constant speed operation)  6 (06 Hex): OU1 Overvoltage protection (during acceleration)  7 (07 Hex): OU2 Overvoltage protection (during deceleration)  8 (08 Hex): OU3 Overvoltage protection (during constant speed operation or stopping)  10 ( 0A Hex): LU Undervoltage protection  11 (0B Hex): Lin Input phase loss protection  16 (10 Hex): PbF Inrush Current Prevention Circuit Error  17 (11 Hex): OH1 Heat sink overheat  18 (12 Hex): OH2 External alarm input  19 (13 Hex): OH3 Inverter internal overheat  20 (14 Hex): OH4 Motor protection (PTC thermistor)  22 (16 Hex): dbH Braking resistor overheat  23 (17 Hex): OL1 Motor 1 overload  24 (18 Hex): OL2 Motor 2 overload  25 (19 Hex): OLU Inverter overload  27 (1B Hex): OS Over speed protection  28 (1C Hex): Pg PG disconnection</p>	0	-	-

Parameter No.	Function name	Monitor or data range	Default data	Setting during RUN	Unit
M16	Latest Alarm Contents	31 (1F Hex): Er1 Memory error 32 (20 Hex): Er2 Operator communications error 33 (21 Hex): Er3 CPU error 34 (22 Hex): Er4 Option card 36 (24 Hex): Er6 Operation protection 37 (25 Hex): Er7 Tuning error 42 (2A Hex): Erd Detection of step-out 46 (2E Hex): OPL Output phase loss protection 47 (2F Hex): ErE Following error (excessive speed deviation) 50 (32 Hex): ErC Magnetic pole position detection error 51 (33 Hex): ErF Data save error in case of undervoltage 52 (34 Hex): d0 Excessive positioning deviation 53 (35 Hex): ErP RS-485 communications error (Option card) 56 (38 Hex): Ero Position control error 57 (39 Hex): ECF EN circuit failure 58 (3A Hex): CoF PID feedback disconnection detected 59 (3B Hex): dbA DB transistor trouble 65 (41 Hex): Reserved 68 (44 Hex): ErU Support tool communication disconnection 70 (46 Hex): OH6 Charging resistor overheat 253 (FD Hex): Lok Locked by password 254 (FE Hex): Err Mock alarm (Subcode = 9998)	0	-	-

Parameter No.	Function name	Monitor or data range	Default data	Setting during RUN	Unit
M17	Last Alarm Contents	<div style="display: flex; justify-content: space-between; border: 1px solid black; padding: 2px;"> <span>V/f</span> <span>DTV</span> <span>PG V/f</span> <span>PG DTV</span> </div> <div style="display: flex; justify-content: space-between; border: 1px solid black; padding: 2px; margin-top: 5px;"> <span>SLV</span> <span>PGV</span> <span>PM SLV</span> <span>PM PGV</span> </div> <p>0 (00 Hex): No alarm  1 (01 Hex): OC1 Overcurrent protection (during acceleration)  2 (02 Hex): OC2 Overcurrent protection (during deceleration)  3 (03 Hex): OC3 Overcurrent protection (during constant speed operation)  6 (06 Hex): OU1 Overvoltage protection (during acceleration)  7 (07 Hex): OU2 Overvoltage protection (during deceleration)  8 (08 Hex): OU3 Overvoltage protection (during constant speed operation or stopping)  10 ( 0A Hex): LU Undervoltage protection  11 (0B Hex): Lin Input phase loss protection  16 (10 Hex): PbF Inrush Current Prevention Circuit Error  17 (11 Hex): OH1 Heat sink overheat  18 (12 Hex): OH2 External alarm input  19 (13 Hex): OH3 Inverter internal overheat  20 (14 Hex): OH4 Motor protection (PTC thermistor)  22 (16 Hex): dbH Braking resistor overheat  23 (17 Hex): OL1 Motor 1 overload  24 (18 Hex): OL2 Motor 2 overload  25 (19 Hex): OLU Inverter overload  27 (1B Hex): OS Over speed protection  28 (1C Hex): Pg PG disconnection</p>	0	-	-

Parameter No.	Function name	Monitor or data range	Default data	Setting during RUN	Unit
M17	Last Alarm Contents	31 (1F Hex): Er1 Memory error 32 (20 Hex): Er2 Operator communications error 33 (21 Hex): Er3 CPU error 34 (22 Hex): Er4 Option card 36 (24 Hex): Er6 Operation protection 37 (25 Hex): Er7 Tuning error 42 (2A Hex): Erd Detection of step-out 46 (2E Hex): OPL Output phase loss protection 47 (2F Hex): ErE Following error (excessive speed deviation) 50 (32 Hex): ErC Magnetic pole position detection error 51 (33 Hex): ErF Data save error in case of undervoltage 52 (34 Hex): d0 Excessive positioning deviation 53 (35 Hex): ErP RS-485 communications error (Option card) 56 (38 Hex): Ero Position control error 57 (39 Hex): ECF EN circuit failure 58 (3A Hex): CoF PID feedback disconnection detected 59 (3B Hex): dbA DB transistor trouble 65 (41 Hex): Reserved 68 (44 Hex): ErU Support tool communication disconnection 70 (46 Hex): OH6 Charging resistor overheat 253 (FD Hex): Lok Locked by password 254 (FE Hex): Err Mock alarm (Subcode = 9998)	0	-	-

Parameter No.	Function name	Monitor or data range	Default data	Setting during RUN	Unit
M18	Second Last Alarm Contents	<div style="display: flex; justify-content: space-between; border: 1px solid black; padding: 2px;"> <span>V/f</span> <span>DTV</span> <span>PG V/f</span> <span>PG DTV</span> </div> <div style="display: flex; justify-content: space-between; border: 1px solid black; padding: 2px; margin-top: 5px;"> <span>SLV</span> <span>PGV</span> <span>PM SLV</span> <span>PM PGV</span> </div> <p>0 (00 Hex): No alarm  1 (01 Hex): OC1 Overcurrent protection (during acceleration)  2 (02 Hex): OC2 Overcurrent protection (during deceleration)  3 (03 Hex): OC3 Overcurrent protection (during constant speed operation)  6 (06 Hex): OU1 Overvoltage protection (during acceleration)  7 (07 Hex): OU2 Overvoltage protection (during deceleration)  8 (08 Hex): OU3 Overvoltage protection (during constant speed operation or stopping)  10 ( 0A Hex): LU Undervoltage protection  11 (0B Hex): Lin Input phase loss protection  16 (10 Hex): PbF Inrush Current Prevention Circuit Error  17 (11 Hex): OH1 Heat sink overheat  18 (12 Hex): OH2 External alarm input  19 (13 Hex): OH3 Inverter internal overheat  20 (14 Hex): OH4 Motor protection (PTC thermistor)  22 (16 Hex): dbH Braking resistor overheat  23 (17 Hex): OL1 Motor 1 overload  24 (18 Hex): OL2 Motor 2 overload  25 (19 Hex): OLU Inverter overload  27 (1B Hex): OS Over speed protection  28 (1C Hex): Pg PG disconnection</p>	0	-	-

Parameter No.	Function name	Monitor or data range	Default data	Setting during RUN	Unit
M18	Second Last Alarm Contents	31 (1F Hex): Er1 Memory error 32 (20 Hex): Er2 Operator communications error 33 (21 Hex): Er3 CPU error 34 (22 Hex): Er4 Option card 36 (24 Hex): Er6 Operation protection 37 (25 Hex): Er7 Tuning error 42 (2A Hex): Erd Detection of step-out 46 (2E Hex): OPL Output phase loss protection 47 (2F Hex): ErE Following error (excessive speed deviation) 50 (32 Hex): ErC Magnetic pole position detection error 51 (33 Hex): ErF Data save error in case of undervoltage 52 (34 Hex): d0 Excessive positioning deviation 53 (35 Hex): ErP RS-485 communications error (Option card) 56 (38 Hex): Ero Position control error 57 (39 Hex): ECF EN circuit failure 58 (3A Hex): CoF PID feedback disconnection detected 59 (3B Hex): dbA DB transistor trouble 65 (41 Hex): Reserved 68 (44 Hex): ErU Support tool communication disconnection 70 (46 Hex): OH6 Charging resistor overheat 253 (FD Hex): Lok Locked by password 254 (FE Hex): Err Mock alarm (Subcode = 9998)	0	-	-



Parameter No.	Function name	Monitor or data range	Default data	Setting during RUN	Unit
M19	Third Last Alarm Contents	<div style="display: flex; justify-content: space-between; border: 1px solid black; padding: 2px;"> <span>V/f</span> <span>DTV</span> <span>PG V/f</span> <span>PG DTV</span> </div> <div style="display: flex; justify-content: space-between; border: 1px solid black; padding: 2px; margin-top: 5px;"> <span>SLV</span> <span>PGV</span> <span>PM SLV</span> <span>PM PGV</span> </div> <p>0 (00 Hex): No alarm  1 (01 Hex): OC1 Overcurrent protection (during acceleration)  2 (02 Hex): OC2 Overcurrent protection (during deceleration)  3 (03 Hex): OC3 Overcurrent protection (during constant speed operation)  6 (06 Hex): OU1 Overvoltage protection (during acceleration)  7 (07 Hex): OU2 Overvoltage protection (during deceleration)  8 (08 Hex): OU3 Overvoltage protection (during constant speed operation or stopping)  10 ( 0A Hex): LU Undervoltage protection  11 (0B Hex): Lin Input phase loss protection  16 (10 Hex): PbF Inrush Current Prevention Circuit Error  17 (11 Hex): OH1 Heat sink overheat  18 (12 Hex): OH2 External alarm input  19 (13 Hex): OH3 Inverter internal overheat  20 (14 Hex): OH4 Motor protection (PTC thermistor)  22 (16 Hex): dbH Braking resistor overheat  23 (17 Hex): OL1 Motor 1 overload  24 (18 Hex): OL2 Motor 2 overload  25 (19 Hex): OLU Inverter overload  27 (1B Hex): OS Over speed protection  28 (1C Hex): Pg PG disconnection</p>	0	-	-

Parameter No.	Function name	Monitor or data range	Default data	Setting during RUN	Unit
M19	Third Last Alarm Contents	31 (1F Hex): Er1 Memory error 32 (20 Hex): Er2 Operator communications error 33 (21 Hex): Er3 CPU error 34 (22 Hex): Er4 Option card 36 (24 Hex): Er6 Operation protection 37 (25 Hex): Er7 Tuning error 42 (2A Hex): Erd Detection of step-out 46 (2E Hex): OPL Output phase loss protection 47 (2F Hex): ErE Following error (excessive speed deviation) 50 (32 Hex): ErC Magnetic pole position detection error 51 (33 Hex): ErF Data save error in case of undervoltage 52 (34 Hex): d0 Excessive positioning deviation 53 (35 Hex): ErP RS-485 communications error (Option card) 56 (38 Hex): Ero Position control error 57 (39 Hex): ECF EN circuit failure 58 (3A Hex): CoF PID feedback disconnection detected 59 (3B Hex): dbA DB transistor trouble 65 (41 Hex): Reserved 68 (44 Hex): ErU Support tool communication disconnection 70 (46 Hex): OH6 Charging resistor overheat 253 (FD Hex): Lok Locked by password 254 (FE Hex): Err Mock alarm (Subcode = 9998)	0	-	-
M20	Cumulative Operation Time	<input type="checkbox"/> V/f <input type="checkbox"/> DTV <input type="checkbox"/> PG V/f <input type="checkbox"/> PG DTV <input type="checkbox"/> SLV <input type="checkbox"/> PGV <input type="checkbox"/> PM SLV <input type="checkbox"/> PM PGV 0 to 655350 hour	0	-	h
M21	Main Circuit DC Voltage	<input type="checkbox"/> V/f <input type="checkbox"/> DTV <input type="checkbox"/> PG V/f <input type="checkbox"/> PG DTV <input type="checkbox"/> SLV <input type="checkbox"/> PGV <input type="checkbox"/> PM SLV <input type="checkbox"/> PM PGV 0 to 1,000 V	0	-	V

Parameter No.	Function name	Monitor or data range	Default data	Setting during RUN	Unit
M25	ROM Version	<input type="checkbox"/> V/f <input type="checkbox"/> DTV <input type="checkbox"/> PG V/f <input type="checkbox"/> PG DTV <input type="checkbox"/> SLV <input type="checkbox"/> PGV <input type="checkbox"/> PM SLV <input type="checkbox"/> PM PGV 0 to 9999	100	-	-
M26	Transmission Error Transaction Code for RS-485 Port1	<input type="checkbox"/> V/f <input type="checkbox"/> DTV <input type="checkbox"/> PG V/f <input type="checkbox"/> PG DTV <input type="checkbox"/> SLV <input type="checkbox"/> PGV <input type="checkbox"/> PM SLV <input type="checkbox"/> PM PGV 1: Improper FC (Non-existent parameter block specified) [RTU] 2: Improper address (Non-existent parameter number specified) [RTU] 3: Improper data (Range error) [RTU] 7: NAK (Link priority, no right, write disabled) [RTU] 71: Checksum error, CRC error 72: Parity error 73: Framing error, overrun error, buffer full	0	-	-
M27	Final Frequency Reference Monitor on Alarm Monitor	<input type="checkbox"/> V/f <input type="checkbox"/> DTV <input type="checkbox"/> PG V/f <input type="checkbox"/> PG DTV <input type="checkbox"/> SLV <input type="checkbox"/> PGV <input type="checkbox"/> PM SLV <input type="checkbox"/> PM PGV -32,768 to 32,767	0	-	-
M28	Final Torque Command Monitor on Alarm	<input type="checkbox"/> V/f <input type="checkbox"/> DTV <input type="checkbox"/> PG V/f <input type="checkbox"/> PG DTV <input type="checkbox"/> SLV <input type="checkbox"/> PGV <input type="checkbox"/> PM SLV <input type="checkbox"/> PM PGV -327.68 to 327.67	0	-	%
M29	Final Torque Current Command Monitor on Alarm	<input type="checkbox"/> V/f <input type="checkbox"/> DTV <input type="checkbox"/> PG V/f <input type="checkbox"/> PG DTV <input type="checkbox"/> SLV <input type="checkbox"/> PGV <input type="checkbox"/> PM SLV <input type="checkbox"/> PM PGV -327.68 to 327.67	0	-	%
M30	Final Magnetic flux command Monitor on Alarm	<input type="checkbox"/> V/f <input type="checkbox"/> DTV <input type="checkbox"/> PG V/f <input type="checkbox"/> PG DTV <input type="checkbox"/> SLV <input type="checkbox"/> PGV <input type="checkbox"/> PM SLV <input type="checkbox"/> PM PGV -327.68 to 327.67	0	-	%
M31	Final Frequency Reference Monitor on Alarm	<input type="checkbox"/> V/f <input type="checkbox"/> DTV <input type="checkbox"/> PG V/f <input type="checkbox"/> PG DTV <input type="checkbox"/> SLV <input type="checkbox"/> PGV <input type="checkbox"/> PM SLV <input type="checkbox"/> PM PGV 0.00 to 655.35	0	-	Hz
M32	Output Frequency Monitor on Alarm without Slip Compensation	<input type="checkbox"/> V/f <input type="checkbox"/> DTV <input type="checkbox"/> PG V/f <input type="checkbox"/> PG DTV <input type="checkbox"/> SLV <input type="checkbox"/> PGV <input type="checkbox"/> PM SLV <input type="checkbox"/> PM PGV -32768 to 32767	0	-	-
M33	Output Torque Monitor on Alarm	<input type="checkbox"/> V/f <input type="checkbox"/> DTV <input type="checkbox"/> PG V/f <input type="checkbox"/> PG DTV <input type="checkbox"/> SLV <input type="checkbox"/> PGV <input type="checkbox"/> PM SLV <input type="checkbox"/> PM PGV -327.68 to 327.67	0	-	%

Parameter No.	Function name	Monitor or data range	Default data	Setting during RUN	Unit
M34	Torque Current Monitor on Alarm	<div style="display: flex; justify-content: space-between; border-bottom: 1px solid black; padding-bottom: 2px;"> <span>V/f</span> <span>DTV</span> <span>PG V/f</span> <span>PG DTV</span> </div> <div style="display: flex; justify-content: space-between; border-bottom: 1px solid black; padding-bottom: 2px;"> <span>SLV</span> <span>PGV</span> <span>PM SLV</span> <span>PM PGV</span> </div> -327.68 to 327.67	0	-	%
M35	Output Frequency Monitor on Alarm	<div style="display: flex; justify-content: space-between; border-bottom: 1px solid black; padding-bottom: 2px;"> <span>V/f</span> <span>DTV</span> <span>PG V/f</span> <span>PG DTV</span> </div> <div style="display: flex; justify-content: space-between; border-bottom: 1px solid black; padding-bottom: 2px;"> <span>SLV</span> <span>PGV</span> <span>PM SLV</span> <span>PM PGV</span> </div> 0.00 to 655.35 Hz	0	-	Hz
M36	Input Power Monitor on Alarm	<div style="display: flex; justify-content: space-between; border-bottom: 1px solid black; padding-bottom: 2px;"> <span>V/f</span> <span>DTV</span> <span>PG V/f</span> <span>PG DTV</span> </div> <div style="display: flex; justify-content: space-between; border-bottom: 1px solid black; padding-bottom: 2px;"> <span>SLV</span> <span>PGV</span> <span>PM SLV</span> <span>PM PGV</span> </div> 0.00 to 399.99	0	-	%
M37	Output Current Effective Value Monitor on Alarm	<div style="display: flex; justify-content: space-between; border-bottom: 1px solid black; padding-bottom: 2px;"> <span>V/f</span> <span>DTV</span> <span>PG V/f</span> <span>PG DTV</span> </div> <div style="display: flex; justify-content: space-between; border-bottom: 1px solid black; padding-bottom: 2px;"> <span>SLV</span> <span>PGV</span> <span>PM SLV</span> <span>PM PGV</span> </div> 0.00 to 399.99 %	0	-	%
M38	Output Voltage Effective Value Monitor on Alarm	<div style="display: flex; justify-content: space-between; border-bottom: 1px solid black; padding-bottom: 2px;"> <span>V/f</span> <span>DTV</span> <span>PG V/f</span> <span>PG DTV</span> </div> <div style="display: flex; justify-content: space-between; border-bottom: 1px solid black; padding-bottom: 2px;"> <span>SLV</span> <span>PGV</span> <span>PM SLV</span> <span>PM PGV</span> </div> 0.0 to 1000.0 V	0	-	V
M39	Operation Command Monitor on Alarm	<div style="display: flex; justify-content: space-between; border-bottom: 1px solid black; padding-bottom: 2px;"> <span>V/f</span> <span>DTV</span> <span>PG V/f</span> <span>PG DTV</span> </div> <div style="display: flex; justify-content: space-between; border-bottom: 1px solid black; padding-bottom: 2px;"> <span>SLV</span> <span>PGV</span> <span>PM SLV</span> <span>PM PGV</span> </div> Bit 0: FWD Bit 1: REV Bit 2: DI1 Bit 3: DI2 Bit 4: DI3 Bit 5: DI4 Bit 6: DI5 Bit 7: --- Bit 8: --- Bit 9: --- Bit 10: --- Bit 11: EN Bit 12: --- Bit 13: DI6 Bit 14: DI7 Bit 15: RST	0	-	-

Parameter No.	Function name	Monitor or data range	Default data	Setting during RUN	Unit
M40	Operation Status 1 Monitor on Alarm	<div style="display: flex; justify-content: space-between; border: 1px solid black; padding: 2px;"> <span>V/f</span> <span>DTV</span> <span>PG V/f</span> <span>PG DTV</span> </div> <div style="display: flex; justify-content: space-between; border: 1px solid black; padding: 2px; margin-top: 2px;"> <span>SLV</span> <span>PGV</span> <span>PM SLV</span> <span>PM PGV</span> </div> <p>Bit15: BUSY (During Parameter data writing)            Bit14: -            Bit13: -            Bit12: RL (Communications effective)            Bit11: ALM (Alarm relay)            Bit10: DEC (During deceleration)            Bit9: ACC (During acceleration)            Bit8: IL (During current limiting)            Bit7: VL (During voltage limiting)            Bit6: TL (Torque limiting)            Bit5: NUV (Main circuit DC voltage established)            Bit4: BRK (During braking)            Bit3: INT (Inverter shut down)            Bit2: EXT (During DC braking or during pre-exciting)            Bit1: REV (During reverse operation)            Bit0: FWD (During forward operation)</p>	0	-	-
M41	Latest Output Terminal Information Monitor on Alarm	<div style="display: flex; justify-content: space-between; border: 1px solid black; padding: 2px;"> <span>V/f</span> <span>DTV</span> <span>PG V/f</span> <span>PG DTV</span> </div> <div style="display: flex; justify-content: space-between; border: 1px solid black; padding: 2px; margin-top: 2px;"> <span>SLV</span> <span>PGV</span> <span>PM SLV</span> <span>PM PGV</span> </div> <p>Bit15: ---            Bit14: ---            Bit13: ---            Bit12: ---            Bit11: ---            Bit10: ---            Bit9: ---            Bit8: RO            Bit7: ---            Bit6: ---            Bit5: ---            Bit4: ---            Bit3: ---            Bit2: ---            Bit1: DO2            Bit0: DO1</p>	0	-	-
M42	Cumulative Operation Time Monitor on Alarm	<div style="display: flex; justify-content: space-between; border: 1px solid black; padding: 2px;"> <span>V/f</span> <span>DTV</span> <span>PG V/f</span> <span>PG DTV</span> </div> <div style="display: flex; justify-content: space-between; border: 1px solid black; padding: 2px; margin-top: 2px;"> <span>SLV</span> <span>PGV</span> <span>PM SLV</span> <span>PM PGV</span> </div> <p>0 to 655,350 hour</p>	0	-	h

Parameter No.	Function name	Monitor or data range	Default data	Setting during RUN	Unit
M43	Main Circuit DC Voltage Monitor on Alarm	<div style="display: flex; justify-content: space-between; border-bottom: 1px solid black; padding-bottom: 2px;"> <span>V/f</span> <span>DTV</span> <span>PG V/f</span> <span>PG DTV</span> </div> <div style="display: flex; justify-content: space-between; border-bottom: 1px solid black; padding-bottom: 2px;"> <span>SLV</span> <span>PGV</span> <span>PM SLV</span> <span>PM PGV</span> </div> 0 to 1,000 V	0	-	V
M44	Inverter Internal Air Temperature Monitor on Alarm	<div style="display: flex; justify-content: space-between; border-bottom: 1px solid black; padding-bottom: 2px;"> <span>V/f</span> <span>DTV</span> <span>PG V/f</span> <span>PG DTV</span> </div> <div style="display: flex; justify-content: space-between; border-bottom: 1px solid black; padding-bottom: 2px;"> <span>SLV</span> <span>PGV</span> <span>PM SLV</span> <span>PM PGV</span> </div> -32,768 to 32,767	0	-	degC
M45	Heat Sink Temperature Monitor on Alarm	<div style="display: flex; justify-content: space-between; border-bottom: 1px solid black; padding-bottom: 2px;"> <span>V/f</span> <span>DTV</span> <span>PG V/f</span> <span>PG DTV</span> </div> <div style="display: flex; justify-content: space-between; border-bottom: 1px solid black; padding-bottom: 2px;"> <span>SLV</span> <span>PGV</span> <span>PM SLV</span> <span>PM PGV</span> </div> -32,768 to 32,767	0	-	degC
M46	Life of Main Circuit Capacitor Monitor	<div style="display: flex; justify-content: space-between; border-bottom: 1px solid black; padding-bottom: 2px;"> <span>V/f</span> <span>DTV</span> <span>PG V/f</span> <span>PG DTV</span> </div> <div style="display: flex; justify-content: space-between; border-bottom: 1px solid black; padding-bottom: 2px;"> <span>SLV</span> <span>PGV</span> <span>PM SLV</span> <span>PM PGV</span> </div> 0.0 to 100.0	0	-	%
M47	Life of PC Board Electrolytic Capacitor	<div style="display: flex; justify-content: space-between; border-bottom: 1px solid black; padding-bottom: 2px;"> <span>V/f</span> <span>DTV</span> <span>PG V/f</span> <span>PG DTV</span> </div> <div style="display: flex; justify-content: space-between; border-bottom: 1px solid black; padding-bottom: 2px;"> <span>SLV</span> <span>PGV</span> <span>PM SLV</span> <span>PM PGV</span> </div> 0 to 65,535 (in 10 hours)	0	-	10 hex
M48	Life of Cooling Fan	<div style="display: flex; justify-content: space-between; border-bottom: 1px solid black; padding-bottom: 2px;"> <span>V/f</span> <span>DTV</span> <span>PG V/f</span> <span>PG DTV</span> </div> <div style="display: flex; justify-content: space-between; border-bottom: 1px solid black; padding-bottom: 2px;"> <span>SLV</span> <span>PGV</span> <span>PM SLV</span> <span>PM PGV</span> </div> 0 to 9,999 (in 10 hours)	0	-	10 hex
M49	Input Terminal [AI1] Input Voltage Monitor	<div style="display: flex; justify-content: space-between; border-bottom: 1px solid black; padding-bottom: 2px;"> <span>V/f</span> <span>DTV</span> <span>PG V/f</span> <span>PG DTV</span> </div> <div style="display: flex; justify-content: space-between; border-bottom: 1px solid black; padding-bottom: 2px;"> <span>SLV</span> <span>PGV</span> <span>PM SLV</span> <span>PM PGV</span> </div> -32768 to 32767 20000: 10 V	0	-	-
M50	Input Terminal [AI2] Input Current (AI) Monitor	<div style="display: flex; justify-content: space-between; border-bottom: 1px solid black; padding-bottom: 2px;"> <span>V/f</span> <span>DTV</span> <span>PG V/f</span> <span>PG DTV</span> </div> <div style="display: flex; justify-content: space-between; border-bottom: 1px solid black; padding-bottom: 2px;"> <span>SLV</span> <span>PGV</span> <span>PM SLV</span> <span>PM PGV</span> </div> 0 to 32767 0: 0 A 20000: 20 mA	0	-	-
M54	Input Terminal [AI2] Input Voltage (AIV) Monitor	<div style="display: flex; justify-content: space-between; border-bottom: 1px solid black; padding-bottom: 2px;"> <span>V/f</span> <span>DTV</span> <span>PG V/f</span> <span>PG DTV</span> </div> <div style="display: flex; justify-content: space-between; border-bottom: 1px solid black; padding-bottom: 2px;"> <span>SLV</span> <span>PGV</span> <span>PM SLV</span> <span>PM PGV</span> </div> -32768 to 32767 20000: 10 V	0	-	-
M56	Input Terminal [PTC] Input Voltage Monitor	<div style="display: flex; justify-content: space-between; border-bottom: 1px solid black; padding-bottom: 2px;"> <span>V/f</span> <span>DTV</span> <span>PG V/f</span> <span>PG DTV</span> </div> <div style="display: flex; justify-content: space-between; border-bottom: 1px solid black; padding-bottom: 2px;"> <span>SLV</span> <span>PGV</span> <span>PM SLV</span> <span>PM PGV</span> </div> -32768 to 32767 20000: 10 V	0	-	-
M57	Electric Angle Monitor	<div style="display: flex; justify-content: space-between; border-bottom: 1px solid black; padding-bottom: 2px;"> <span>V/f</span> <span>DTV</span> <span>PG V/f</span> <span>PG DTV</span> </div> <div style="display: flex; justify-content: space-between; border-bottom: 1px solid black; padding-bottom: 2px;"> <span>SLV</span> <span>PGV</span> <span>PM SLV</span> <span>PM PGV</span> </div> 0.0 to 359.9°	0	-	deg

Parameter No.	Function name	Monitor or data range	Default data	Setting during RUN	Unit
M58	Rotor Angle Monitor	<div style="display: flex; justify-content: space-between; border: 1px solid black; padding: 2px;"> <span>V/f</span> <span>DTV</span> <span>PG V/f</span> <span>PG DTV</span> </div> <div style="display: flex; justify-content: space-between; border: 1px solid black; padding: 2px;"> <span>SLV</span> <span>PGV</span> <span>PM SLV</span> <span>PM PGV</span> </div> 0.0 to 359.9°	0	-	deg
M59	Motor Electronic Thermal Monitor	<div style="display: flex; justify-content: space-between; border: 1px solid black; padding: 2px;"> <span>V/f</span> <span>DTV</span> <span>PG V/f</span> <span>PG DTV</span> </div> <div style="display: flex; justify-content: space-between; border: 1px solid black; padding: 2px;"> <span>SLV</span> <span>PGV</span> <span>PM SLV</span> <span>PM PGV</span> </div> 0 to 100%	0	-	%
M61	Inverter Internal Air Temperature Monitor	<div style="display: flex; justify-content: space-between; border: 1px solid black; padding: 2px;"> <span>V/f</span> <span>DTV</span> <span>PG V/f</span> <span>PG DTV</span> </div> <div style="display: flex; justify-content: space-between; border: 1px solid black; padding: 2px;"> <span>SLV</span> <span>PGV</span> <span>PM SLV</span> <span>PM PGV</span> </div> -3276.8~3276.7	0	-	degC
M62	Fin Temperature Monitor	<div style="display: flex; justify-content: space-between; border: 1px solid black; padding: 2px;"> <span>V/f</span> <span>DTV</span> <span>PG V/f</span> <span>PG DTV</span> </div> <div style="display: flex; justify-content: space-between; border: 1px solid black; padding: 2px;"> <span>SLV</span> <span>PGV</span> <span>PM SLV</span> <span>PM PGV</span> </div> -3276.8~3276.7	0	-	degC
M63	Load Factor Monitor	<div style="display: flex; justify-content: space-between; border: 1px solid black; padding: 2px;"> <span>V/f</span> <span>DTV</span> <span>PG V/f</span> <span>PG DTV</span> </div> <div style="display: flex; justify-content: space-between; border: 1px solid black; padding: 2px;"> <span>SLV</span> <span>PGV</span> <span>PM SLV</span> <span>PM PGV</span> </div> -327.68 to 327.67	0	-	%
M64	Motor Output Monitor	<div style="display: flex; justify-content: space-between; border: 1px solid black; padding: 2px;"> <span>V/f</span> <span>DTV</span> <span>PG V/f</span> <span>PG DTV</span> </div> <div style="display: flex; justify-content: space-between; border: 1px solid black; padding: 2px;"> <span>SLV</span> <span>PGV</span> <span>PM SLV</span> <span>PM PGV</span> </div> -327.68 to 327.67 % of rated power	0	-	%
M65	Motor Output Monitor on Alarm	<div style="display: flex; justify-content: space-between; border: 1px solid black; padding: 2px;"> <span>V/f</span> <span>DTV</span> <span>PG V/f</span> <span>PG DTV</span> </div> <div style="display: flex; justify-content: space-between; border: 1px solid black; padding: 2px;"> <span>SLV</span> <span>PGV</span> <span>PM SLV</span> <span>PM PGV</span> </div> -32768 to 32767	0	-	-
M66	Speed Detection Monitor	<div style="display: flex; justify-content: space-between; border: 1px solid black; padding: 2px;"> <span>V/f</span> <span>DTV</span> <span>PG V/f</span> <span>PG DTV</span> </div> <div style="display: flex; justify-content: space-between; border: 1px solid black; padding: 2px;"> <span>SLV</span> <span>PGV</span> <span>PM SLV</span> <span>PM PGV</span> </div> -32768 to 32767	0	-	-
M67	Transmission Error Transaction Code for RS485 Port	<div style="display: flex; justify-content: space-between; border: 1px solid black; padding: 2px;"> <span>V/f</span> <span>DTV</span> <span>PG V/f</span> <span>PG DTV</span> </div> <div style="display: flex; justify-content: space-between; border: 1px solid black; padding: 2px;"> <span>SLV</span> <span>PGV</span> <span>PM SLV</span> <span>PM PGV</span> </div> 1: Improper FC (Non-existent parameter block specified) [RTU] 2: Improper address (Non-existent parameter number specified) [RTU] 3: Improper data (Range error) [RTU] 7: NAK (Link priority, no right, write disabled) [RTU] 71: Checksum error, CRC error 72: Parity error 73: Framing error, overrun error, buffer full	0	-	-

Parameter No.	Function name	Monitor or data range	Default data	Setting during RUN	Unit
M68	Do not use	-	-	-	-
M69	Inverter Rated Current	<div style="display: flex; justify-content: space-between; border: 1px solid black; padding: 2px;"> <span>V/f</span> <span>DTV</span> <span>PG V/f</span> <span>PG DTV</span> </div> <div style="display: flex; justify-content: space-between; border: 1px solid black; padding: 2px;"> <span>SLV</span> <span>PGV</span> <span>PM SLV</span> <span>PM PGV</span> </div> 0.00 to 9999A	0	-	A
M70	Running Status 3 Monitor	<div style="display: flex; justify-content: space-between; border: 1px solid black; padding: 2px;"> <span>V/f</span> <span>DTV</span> <span>PG V/f</span> <span>PG DTV</span> </div> <div style="display: flex; justify-content: space-between; border: 1px solid black; padding: 2px;"> <span>SLV</span> <span>PGV</span> <span>PM SLV</span> <span>PM PGV</span> </div> Bit15: --- Bit14: OL (Overload warning) Bit13: LOC (Light load detection) Bit12: OL2 (Overload warning 2) Bit11: OLP (During active drive) Bit10: LIFE (Life warning) Bit9: OHF (Fin Overheat warning) Bit8: TRY (During retry) Bit7: FAN (Fan operation signal) Bit6: REF (RUN command source) Bit5: THM (Thermal warning) Bit4: IPF (During restart after instantaneous power failure) Bit3: SETM (2nd motor selection) Bit2: IRDY (Operation ready) Bit1: FDT1 (Over set Frequency arrival) Bit0: FAR1 (Constant speed arrival)	0	-	-



Parameter No.	Function name	Monitor or data range	Default data	Setting during RUN	Unit
M71	Input Terminal Monitor	<div style="display: flex; justify-content: space-between; margin-bottom: 5px;"> <span>V/f</span> <span>DTV</span> <span>PG V/f</span> <span>PG DTV</span> </div> <div style="display: flex; justify-content: space-between; margin-bottom: 5px;"> <span>SLV</span> <span>PGV</span> <span>PM SLV</span> <span>PM PGV</span> </div> Bit15: RST Bit14: DI7 Bit13: DI6 Bit12: - Bit11: EN Bit10: - Bit9: - Bit8: - Bit7: - Bit6: DI5 Bit5: DI4 Bit4: DI3 Bit3: DI2 Bit2: DI1 Bit1: REV Bit0: FWD	0	-	-
M72	Do not use	-	-	-	-
M73	PID Output Monitor	<div style="display: flex; justify-content: space-between; margin-bottom: 5px;"> <span>V/f</span> <span>DTV</span> <span>PG V/f</span> <span>PG DTV</span> </div> <div style="display: flex; justify-content: space-between; margin-bottom: 5px;"> <span>SLV</span> <span>PGV</span> <span>PM SLV</span> <span>PM PGV</span> </div> -32,768 to 32,767 -20,000 = -100%, 20,000 = 100%	0	-	-

Parameter No.	Function name	Monitor or data range	Default data	Setting during RUN	Unit
M74	Running Status 2 Monitor	<div style="display: flex; justify-content: space-between; border-bottom: 1px solid black; padding-bottom: 2px;"> <span>V/f</span> <span>DTV</span> <span>PG V/f</span> <span>PG DTV</span> </div> <div style="display: flex; justify-content: space-between; border-bottom: 1px solid black; padding-bottom: 2px;"> <span>SLV</span> <span>PGV</span> <span>PM SLV</span> <span>PM PGV</span> </div> <p>Bit15: Motor type  1: PM motor  0: Induction motor  Bit14: During EN circuit diagnosis  Bit7: During speed control (1 during control)  Bit5 to 4: Selected motor  00: 1st motor  01: 2nd motor  10: Reserved  11: Reserved  Bit3 to 0: Control method  0000: V/f control without slip compensation  0001: Dynamic torque vector control  0010: V/f control with slip compensation  0011: V/f control with speed sensor  0100: Dynamic torque vector control with speed sensor  0101: Vector control without speed sensor  0110: Vector control with speed sensor  0111: Torque control (Vector control without speed sensor)  1000: Torque control (Vector control with speed sensor)</p>	0	-	-
M76	Service Life of Main Circuit Capacitor Elapsed Time	<div style="display: flex; justify-content: space-between; border-bottom: 1px solid black; padding-bottom: 2px;"> <span>V/f</span> <span>DTV</span> <span>PG V/f</span> <span>PG DTV</span> </div> <div style="display: flex; justify-content: space-between; border-bottom: 1px solid black; padding-bottom: 2px;"> <span>SLV</span> <span>PGV</span> <span>PM SLV</span> <span>PM PGV</span> </div> <p>0 to 65535 (in 10 hours)</p>	0	-	10 hex
M77	Service Life of Main Circuit Capacitor Remaining Time	<div style="display: flex; justify-content: space-between; border-bottom: 1px solid black; padding-bottom: 2px;"> <span>V/f</span> <span>DTV</span> <span>PG V/f</span> <span>PG DTV</span> </div> <div style="display: flex; justify-content: space-between; border-bottom: 1px solid black; padding-bottom: 2px;"> <span>SLV</span> <span>PGV</span> <span>PM SLV</span> <span>PM PGV</span> </div> <p>0 to 65535 (in 10 hours)</p>	0	-	10 hex
M78	Rotation Speed Command Monitor	<div style="display: flex; justify-content: space-between; border-bottom: 1px solid black; padding-bottom: 2px;"> <span>V/f</span> <span>DTV</span> <span>PG V/f</span> <span>PG DTV</span> </div> <div style="display: flex; justify-content: space-between; border-bottom: 1px solid black; padding-bottom: 2px;"> <span>SLV</span> <span>PGV</span> <span>PM SLV</span> <span>PM PGV</span> </div> <p>-32768 to 32767</p>	0	-	r/min
M79	Rotation Speed Monitor	<div style="display: flex; justify-content: space-between; border-bottom: 1px solid black; padding-bottom: 2px;"> <span>V/f</span> <span>DTV</span> <span>PG V/f</span> <span>PG DTV</span> </div> <div style="display: flex; justify-content: space-between; border-bottom: 1px solid black; padding-bottom: 2px;"> <span>SLV</span> <span>PGV</span> <span>PM SLV</span> <span>PM PGV</span> </div> <p>-32768 to 32767</p>	0	-	r/min

Parameter No.	Function name	Monitor or data range	Default data	Setting during RUN	Unit
M81	1st Remaining Time before the Next Motor Maintenance	<div style="display: flex; justify-content: space-between; border: 1px solid black; padding: 2px;"> <span>V/f</span> <span>DTV</span> <span>PG V/f</span> <span>PG DTV</span> </div> <div style="display: flex; justify-content: space-between; border: 1px solid black; padding: 2px;"> <span>SLV</span> <span>PGV</span> <span>PM SLV</span> <span>PM PGV</span> </div> 0 to 65535 (in 10 hours)	0	-	10 hex
M84	Torque Command at Final	<div style="display: flex; justify-content: space-between; border: 1px solid black; padding: 2px;"> <span>V/f</span> <span>DTV</span> <span>PG V/f</span> <span>PG DTV</span> </div> <div style="display: flex; justify-content: space-between; border: 1px solid black; padding: 2px;"> <span>SLV</span> <span>PGV</span> <span>PM SLV</span> <span>PM PGV</span> </div> -327 to 327	0	-	%
M85	1st Remaining Startup Times before the Next Motor Maintenance	<div style="display: flex; justify-content: space-between; border: 1px solid black; padding: 2px;"> <span>V/f</span> <span>DTV</span> <span>PG V/f</span> <span>PG DTV</span> </div> <div style="display: flex; justify-content: space-between; border: 1px solid black; padding: 2px;"> <span>SLV</span> <span>PGV</span> <span>PM SLV</span> <span>PM PGV</span> </div> 0 to 65,535	0	-	-

Parameter No.	Function name	Monitor or data range	Default data	Setting during RUN	Unit
M86	Latest Light Alarm Factor	<div style="display: flex; flex-wrap: wrap; gap: 5px;"> <span>V/f</span> <span>DTV</span> <span>PG V/f</span> <span>PG DTV</span> </div> <div style="display: flex; flex-wrap: wrap; gap: 5px; margin-top: 5px;"> <span>SLV</span> <span>PGV</span> <span>PM SLV</span> <span>PM PGV</span> </div> <p>0 (0x00 Hex): No alarm  17 (0x11 Hex): OH1 Heat sink  overheat  18 (0x12 Hex): OH2 External  alarm input  19 (0x13 Hex): OH3 Inverter  internal overheat  22 (0x16 Hex): dbH Braking  resistor overheat  23 (0x17 Hex): OL1 Motor 1  overload  24 (0x18 Hex): OL2 Motor 2  overload  34 (0x22 Hex): Er4 Option  card communications error  35 (0x23 Hex): Er5 Option  card error  47 (0x2F Hex): ErE Following  error (excessive speed devia-  tion)  53 (0x35 Hex): ErP RS-485  communications error (Option  card)  56 (0x38 Hex): Ero Position  control error  58 (0x3A Hex): CoF PID feed-  back disconnection detected  100 (0x64 Hex): FAL Detect  DC fan lock  101 (0x65 Hex): OL Motor  overload early warning  102 (0x66 Hex): OH Heat sink  overheat early warning  103 (0x67 Hex): LiF Lifetime  alarm  104 (0x68 Hex): rEF Refer-  ence loss  105 (0x69 Hex): Pid PID alarm  106 (0x6A Hex): UTL Low out-  put torque detection  107 (0x6B Hex): PTC PTC  thermistor activated  108 (0x6C Hex): rTE Inverter  life (Cumulative run time)  109 (0x6D Hex): CnT (Inverter  life, Number of startups)</p>	0	-	-

Parameter No.	Function name	Monitor or data range	Default data	Setting during RUN	Unit
M87	Light Alarm Factor Last	<div style="display: flex; justify-content: space-between; border: 1px solid black; padding: 2px;"> <span>V/f</span> <span>DTV</span> <span>PG V/f</span> <span>PG DTV</span> </div> <div style="display: flex; justify-content: space-between; border: 1px solid black; padding: 2px; margin-top: 5px;"> <span>SLV</span> <span>PGV</span> <span>PM SLV</span> <span>PM PGV</span> </div> <p>0 (0x00 Hex): No alarm  17 (0x11 Hex): OH1 Heat sink  overheat  18 (0x12 Hex): OH2 External  alarm input  19 (0x13 Hex): OH3 Inverter  internal overheat  22 (0x16 Hex): dbH Braking  resistor overheat  23 (0x17 Hex): OL1 Motor 1  overload  24 (0x18 Hex): OL2 Motor 2  overload  34 (0x22 Hex): Er4 Option  card communications error  35 (0x23 Hex): Er5 Option  card error  47 (0x2F Hex): ErE Following  error (excessive speed devia-  tion)  53 (0x35 Hex): ErP RS-485  communications error (Option  card)  56 (0x38 Hex): Ero Position  control error  58 (0x3A Hex): CoF PID feed-  back disconnection detected  100 (0x64 Hex): FAL Detect  DC fan lock  101 (0x65 Hex): OL Motor  overload early warning  102 (0x66 Hex): OH Heat sink  overheat early warning  103 (0x67 Hex): LiF Lifetime  alarm  104 (0x68 Hex): rEF Refer-  ence loss  105 (0x69 Hex): Pid PID alarm  106 (0x6A Hex): UTL Low out-  put torque detection  107 (0x6B Hex): PTC PTC  thermistor activated  108 (0x6C Hex): rTE Inverter  life (Cumulative run time)  109 (0x6D Hex): CnT (Inverter  life, Number of startups)</p>	0	-	-

Parameter No.	Function name	Monitor or data range	Default data	Setting during RUN	Unit
M88	Light Alarm Factor 2nd Last	<div style="display: flex; flex-wrap: wrap; gap: 5px;"> <span>V/f</span> <span>DTV</span> <span>PG V/f</span> <span>PG DTV</span> </div> <div style="display: flex; flex-wrap: wrap; gap: 5px; margin-top: 5px;"> <span>SLV</span> <span>PGV</span> <span>PM SLV</span> <span>PM PGV</span> </div> <p>0 (0x00 Hex): No alarm  17 (0x11 Hex): OH1 Heat sink  overheat  18 (0x12 Hex): OH2 External  alarm input  19 (0x13 Hex): OH3 Inverter  internal overheat  22 (0x16 Hex): dbH Braking  resistor overheat  23 (0x17 Hex): OL1 Motor 1  overload  24 (0x18 Hex): OL2 Motor 2  overload  34 (0x22 Hex): Er4 Option  card communications error  35 (0x23 Hex): Er5 Option  card error  47 (0x2F Hex): ErE Following  error (excessive speed devia-  tion)  53 (0x35 Hex): ErP RS-485  communications error (Option  card)  56 (0x38 Hex): Ero Position  control error  58 (0x3A Hex): CoF PID feed-  back disconnection detected  100 (0x64 Hex): FAL Detect  DC fan lock  101 (0x65 Hex): OL Motor  overload early warning  102 (0x66 Hex): OH Heat sink  overheat early warning  103 (0x67 Hex): LiF Lifetime  alarm  104 (0x68 Hex): rEF Refer-  ence loss  105 (0x69 Hex): Pid PID alarm  106 (0x6A Hex): UTL Low out-  put torque detection  107 (0x6B Hex): PTC PTC  thermistor activated  108 (0x6C Hex): rTE Inverter  life (Cumulative run time)  109 (0x6D Hex): CnT (Inverter  life, Number of startups)</p>	0	-	-

Parameter No.	Function name	Monitor or data range	Default data	Setting during RUN	Unit
M89	Light Alarm Factor 3rd Last	<div style="display: flex; justify-content: space-between; border: 1px solid black; padding: 2px;"> <span>V/f</span> <span>DTV</span> <span>PG V/f</span> <span>PG DTV</span> </div> <div style="display: flex; justify-content: space-between; border: 1px solid black; padding: 2px; margin-top: 2px;"> <span>SLV</span> <span>PGV</span> <span>PM SLV</span> <span>PM PGV</span> </div> <p>0 (0x00 Hex): No alarm  17 (0x11 Hex): OH1 Heat sink  overheat  18 (0x12 Hex): OH2 External  alarm input  19 (0x13 Hex): OH3 Inverter  internal overheat  22 (0x16 Hex): dbH Braking  resistor overheat  23 (0x17 Hex): OL1 Motor 1  overload  24 (0x18 Hex): OL2 Motor 2  overload  34 (0x22 Hex): Er4 Option  card communications error  35 (0x23 Hex): Er5 Option  card error  47 (0x2F Hex): ErE Following  error (excessive speed devia-  tion)  53 (0x35 Hex): ErP RS-485  communications error (Option  card)  56 (0x38 Hex): Ero Position  control error  58 (0x3A Hex): CoF PID feed-  back disconnection detected  100 (0x64 Hex): FAL Detect  DC fan lock  101 (0x65 Hex): OL Motor  overload early warning  102 (0x66 Hex): OH Heat sink  overheat early warning  103 (0x67 Hex): LiF Lifetime  alarm  104 (0x68 Hex): rEF Refer-  ence loss  105 (0x69 Hex): Pid PID alarm  106 (0x6A Hex): UTL Low out-  put torque detection  107 (0x6B Hex): PTC PTC  thermistor activated  108 (0x6C Hex): rTE Inverter  life (Cumulative run time)  109 (0x6D Hex): CnT (Inverter  life, Number of startups)</p>	0	-	-

Parameter No.	Function name	Monitor or data range	Default data	Setting during RUN	Unit
M95	Cumulative Running Time at Tripping	<div style="display: flex; justify-content: space-between; border-bottom: 1px solid black; padding-bottom: 2px;"> <span>V/f</span> <span>DTV</span> <span>PG V/f</span> <span>PG DTV</span> </div> <div style="display: flex; justify-content: space-between; border-bottom: 1px solid black; padding-bottom: 2px;"> <span>SLV</span> <span>PGV</span> <span>PM SLV</span> <span>PM PGV</span> </div> 0 to 655350 hour	0	-	h
M96	Fourth Last Alarm Contents	<div style="display: flex; justify-content: space-between; border-bottom: 1px solid black; padding-bottom: 2px;"> <span>V/f</span> <span>DTV</span> <span>PG V/f</span> <span>PG DTV</span> </div> <div style="display: flex; justify-content: space-between; border-bottom: 1px solid black; padding-bottom: 2px;"> <span>SLV</span> <span>PGV</span> <span>PM SLV</span> <span>PM PGV</span> </div> 0 (00 Hex): No alarm 1 (01 Hex): OC1 Overcurrent protection (during acceleration) 2 (02 Hex): OC2 Overcurrent protection (during deceleration) 3 (03 Hex): OC3 Overcurrent protection (during constant speed operation) 6 (06 Hex): OU1 Overvoltage protection (during acceleration) 7 (07 Hex): OU2 Overvoltage protection (during deceleration) 8 (08 Hex): OU3 Overvoltage protection (during constant speed operation or stopping) 10 ( 0A Hex): LU Undervoltage protection 11 (0B Hex): Lin Input phase loss protection 16 (10 Hex): PbF Inrush Current Prevention Circuit Error 17 (11 Hex): OH1 Heat sink overheat 18 (12 Hex): OH2 External alarm input 19 (13 Hex): OH3 Inverter internal overheat 20 (14 Hex): OH4 Motor protection (PTC thermistor) 22 (16 Hex): dbH Braking resistor overheat 23 (17 Hex): OL1 Motor 1 overload 24 (18 Hex): OL2 Motor 2 overload 25 (19 Hex): OLU Inverter overload 27 (1B Hex): OS Over speed protection 28 (1C Hex): Pg PG disconnection	0	-	-



Parameter No.	Function name	Monitor or data range	Default data	Setting during RUN	Unit
M96	Fourth Last Alarm Contents	31 (1F Hex): Er1 Memory error 32 (20 Hex): Er2 Operator communications error 33 (21 Hex): Er3 CPU error 34 (22 Hex): Er4 Option card 36 (24 Hex): Er6 Operation protection 37 (25 Hex): Er7 Tuning error 42 (2A Hex): Erd Detection of step-out 46 (2E Hex): OPL Output phase loss protection 47 (2F Hex): ErE Following error (excessive speed deviation) 50 (32 Hex): ErC Magnetic pole position detection error 51 (33 Hex): ErF Data save error in case of undervoltage 52 (34 Hex): d0 Excessive positioning deviation 53 (35 Hex): ErP RS-485 communications error (Option card) 56 (38 Hex): Ero Position control error 57 (39 Hex): ECF EN circuit failure 58 (3A Hex): CoF PID feedback disconnection detected 59 (3B Hex): dbA DB transistor trouble 65 (41 Hex): Reserved 68 (44 Hex): ErU Support tool communication disconnection 70 (46 Hex): OH6 Charging resistor overheat 253 (FD Hex): Lok Locked by password 254 (FE Hex): Err Mock alarm (Subcode = 9998)	0	-	-

Parameter No.	Function name	Monitor or data range	Default data	Setting during RUN	Unit
M97	Fifth Last Alarm Contents	<div style="display: flex; justify-content: space-between; border: 1px solid black; padding: 2px;"> <span>V/f</span> <span>DTV</span> <span>PG V/f</span> <span>PG DTV</span> </div> <div style="display: flex; justify-content: space-between; border: 1px solid black; padding: 2px; margin-top: 5px;"> <span>SLV</span> <span>PGV</span> <span>PM SLV</span> <span>PM PGV</span> </div> <p>0 (00 Hex): No alarm  1 (01 Hex): OC1 Overcurrent protection (during acceleration)  2 (02 Hex): OC2 Overcurrent protection (during deceleration)  3 (03 Hex): OC3 Overcurrent protection (during constant speed operation)  6 (06 Hex): OU1 Overvoltage protection (during acceleration)  7 (07 Hex): OU2 Overvoltage protection (during deceleration)  8 (08 Hex): OU3 Overvoltage protection (during constant speed operation or stopping)  10 (0A Hex): LU Undervoltage protection  11 (0B Hex): Lin Input phase loss protection  16 (10 Hex): PbF Inrush Current Prevention Circuit Error  17 (11 Hex): OH1 Heat sink overheat  18 (12 Hex): OH2 External alarm input  19 (13 Hex): OH3 Inverter internal overheat  20 (14 Hex): OH4 Motor protection (PTC thermistor)  22 (16 Hex): dbH Braking resistor overheat  23 (17 Hex): OL1 Motor 1 overload  24 (18 Hex): OL2 Motor 2 overload  25 (19 Hex): OLU Inverter overload  27 (1B Hex): OS Over speed protection  28 (1C Hex): Pg PG disconnection</p>	0	-	-

Parameter No.	Function name	Monitor or data range	Default data	Setting during RUN	Unit
M97	Fifth Last Alarm Contents	31 (1F Hex): Er1 Memory error 32 (20 Hex): Er2 Operator communications error 33 (21 Hex): Er3 CPU error 34 (22 Hex): Er4 Option card 36 (24 Hex): Er6 Operation protection 37 (25 Hex): Er7 Tuning error 42 (2A Hex): Erd Detection of step-out 46 (2E Hex): OPL Output phase loss protection 47 (2F Hex): ErE Following error (excessive speed deviation) 50 (32 Hex): ErC Magnetic pole position detection error 51 (33 Hex): ErF Data save error in case of undervoltage 52 (34 Hex): d0 Excessive positioning deviation 53 (35 Hex): ErP RS-485 communications error (Option card) 56 (38 Hex): Ero Position control error 57 (39 Hex): ECF EN circuit failure 58 (3A Hex): CoF PID feedback disconnection detected 59 (3B Hex): dbA DB transistor trouble 65 (41 Hex): Reserved 68 (44 Hex): ErU Support tool communication disconnection 70 (46 Hex): OH6 Charging resistor overheat 253 (FD Hex): Lok Locked by password 254 (FE Hex): Err Mock alarm (Subcode = 9998)	0	-	-
M114	Do not use	-	-	-	-
M115	PID Output Non Filter	<div style="border: 1px solid black; padding: 2px; display: inline-block;">V/f</div> <div style="border: 1px solid black; padding: 2px; display: inline-block;">DTV</div> <div style="border: 1px solid black; padding: 2px; display: inline-block;">PG V/f</div> <div style="border: 1px solid black; padding: 2px; display: inline-block;">PG DTV</div> <div style="border: 1px solid black; padding: 2px; display: inline-block;">SLV</div> <div style="border: 1px solid black; padding: 2px; display: inline-block;">PGV</div> <div style="border: 1px solid black; padding: 2px; display: inline-block;">PM SLV</div> <div style="border: 1px solid black; padding: 2px; display: inline-block;">PM PGV</div> -150.0 to 150.0	0	-	%

## 4-1-2 Parameter W (Monitor 2)

Parameter No.	Function name	Monitor or Data Range	Default data	Setting during RUN	Unit
W01	Running Status 1 Monitor	<div style="display: flex; justify-content: space-between; margin-bottom: 5px;"> <span>V/f</span> <span>DTV</span> <span>PG V/f</span> <span>PG DTV</span> </div> <div style="display: flex; justify-content: space-between; margin-bottom: 5px;"> <span>SLV</span> <span>PGV</span> <span>PM SLV</span> <span>PM PGV</span> </div> Bit15: BUSY (During Parameter code data writing) Bit14: - Bit13: - Bit12: RL (Communications effective) Bit11: ALM (Alarm relay) Bit10: DEC (During deceleration) Bit9: ACC (During acceleration) Bit8: IL (During current limiting) Bit7: VL (During voltage limiting) Bit6: TL (Torque limiting) Bit5: NUV (Main circuit DC voltage established) Bit4: BRK (During braking) Bit3: INT (Inverter shut down) Bit2: EXT (During DC braking or during pre-exciting) Bit1: REV (During reverse operation) Bit0: FWD (During forward operation)	0	-	-
W02	Frequency Reference Monitor	<div style="display: flex; justify-content: space-between; margin-bottom: 5px;"> <span>V/f</span> <span>DTV</span> <span>PG V/f</span> <span>PG DTV</span> </div> <div style="display: flex; justify-content: space-between; margin-bottom: 5px;"> <span>SLV</span> <span>PGV</span> <span>PM SLV</span> <span>PM PGV</span> </div> 0.00 to 655.35	0	-	Hz
W03	Output Frequency Monitor before Slip Compensation	<div style="display: flex; justify-content: space-between; margin-bottom: 5px;"> <span>V/f</span> <span>DTV</span> <span>PG V/f</span> <span>PG DTV</span> </div> <div style="display: flex; justify-content: space-between; margin-bottom: 5px;"> <span>SLV</span> <span>PGV</span> <span>PM SLV</span> <span>PM PGV</span> </div> 0.00 to 655.35 Hz	0	-	Hz
W04	Output Frequency after Slip Compensation	<div style="display: flex; justify-content: space-between; margin-bottom: 5px;"> <span>V/f</span> <span>DTV</span> <span>PG V/f</span> <span>PG DTV</span> </div> <div style="display: flex; justify-content: space-between; margin-bottom: 5px;"> <span>SLV</span> <span>PGV</span> <span>PM SLV</span> <span>PM PGV</span> </div> 0.00 to 655.35	0	-	Hz
W05	Output Current Monitor	<div style="display: flex; justify-content: space-between; margin-bottom: 5px;"> <span>V/f</span> <span>DTV</span> <span>PG V/f</span> <span>PG DTV</span> </div> <div style="display: flex; justify-content: space-between; margin-bottom: 5px;"> <span>SLV</span> <span>PGV</span> <span>PM SLV</span> <span>PM PGV</span> </div> 0.00 to 99.99 A	0	-	A
W06	Output Voltage Monitor	<div style="display: flex; justify-content: space-between; margin-bottom: 5px;"> <span>V/f</span> <span>DTV</span> <span>PG V/f</span> <span>PG DTV</span> </div> <div style="display: flex; justify-content: space-between; margin-bottom: 5px;"> <span>SLV</span> <span>PGV</span> <span>PM SLV</span> <span>PM PGV</span> </div> 0.0 to 1000.0 V	0	-	V

Parameter No.	Function name	Monitor or Data Range	Default data	Setting during RUN	Unit
W07	Output Torque Monitor	V/f DTV PG V/f PG DTV SLV PGV PM SLV PM PGV -999 to 999	0	-	%
W08	Rotate Speed Monitor	V/f DTV PG V/f PG DTV SLV PGV PM SLV PM PGV 0.00 to 99990	0	-	r/min
W09	Load Shaft Speed	V/f DTV PG V/f PG DTV SLV PGV PM SLV PM PGV 0.00 to 99990	0	-	r/min
W10	Feed Speed	V/f DTV PG V/f PG DTV SLV PGV PM SLV PM PGV 0.00 to 99990	0	-	m/min
W11	PID Process Command	V/f DTV PG V/f PG DTV SLV PGV PM SLV PM PGV -999.00 to 9990.00	0	-	-
W12	PID Feedback Value Monitor	V/f DTV PG V/f PG DTV SLV PGV PM SLV PM PGV -999.00 to 9990.00	0	-	-
W13	Analog Torque Limit Value Monitor	V/f DTV PG V/f PG DTV SLV PGV PM SLV PM PGV -300 to 300 %	300	-	%
W14	Do not use	-	-	-	-
W15	Ratio value Monitor	V/f DTV PG V/f PG DTV SLV PGV PM SLV PM PGV 0.00 to 200.00	0	-	%
W16	Motor Speed Set Value	V/f DTV PG V/f PG DTV SLV PGV PM SLV PM PGV 0.00 to 99990	0	-	r/min
W17	Load Shaft Set Value	V/f DTV PG V/f PG DTV SLV PGV PM SLV PM PGV 0.00 to 99990	0	-	r/min
W18	Feed Speed Set Value	V/f DTV PG V/f PG DTV SLV PGV PM SLV PM PGV 0.00 to 99990	0	-	m/min
W19	Transport Time Set Value for Specified Length	V/f DTV PG V/f PG DTV SLV PGV PM SLV PM PGV 0.00 to 99990 min	999.9	-	min

Parameter No.	Function name	Monitor or Data Range	Default data	Setting during RUN	Unit
W20	Transport Time for Specified Length	<input type="checkbox"/> V/f <input type="checkbox"/> DTV <input type="checkbox"/> PG V/f <input type="checkbox"/> PG DTV <input type="checkbox"/> SLV <input type="checkbox"/> PGV <input type="checkbox"/> PM SLV <input type="checkbox"/> PM PGV 0.00 to 99990 min	999.9	-	min
W21	Power Consumption Monitor	<input type="checkbox"/> V/f <input type="checkbox"/> DTV <input type="checkbox"/> PG V/f <input type="checkbox"/> PG DTV <input type="checkbox"/> SLV <input type="checkbox"/> PGV <input type="checkbox"/> PM SLV <input type="checkbox"/> PM PGV 0.00 to 9999 kW	0	-	kW
W22	Motor Output Power Monitor	<input type="checkbox"/> V/f <input type="checkbox"/> DTV <input type="checkbox"/> PG V/f <input type="checkbox"/> PG DTV <input type="checkbox"/> SLV <input type="checkbox"/> PGV <input type="checkbox"/> PM SLV <input type="checkbox"/> PM PGV 0.00 to 9999kW	0	-	kW
W23	Load Rate Monitor	<input type="checkbox"/> V/f <input type="checkbox"/> DTV <input type="checkbox"/> PG V/f <input type="checkbox"/> PG DTV <input type="checkbox"/> SLV <input type="checkbox"/> PGV <input type="checkbox"/> PM SLV <input type="checkbox"/> PM PGV -999 to 999	0	-	%
W24	Torque Current Monitor	<input type="checkbox"/> V/f <input type="checkbox"/> DTV <input type="checkbox"/> PG V/f <input type="checkbox"/> PG DTV <input type="checkbox"/> SLV <input type="checkbox"/> PGV <input type="checkbox"/> PM SLV <input type="checkbox"/> PM PGV -999 to 999	0	-	%
W25	Output Current Monitor	<input type="checkbox"/> V/f <input type="checkbox"/> DTV <input type="checkbox"/> PG V/f <input type="checkbox"/> PG DTV <input type="checkbox"/> SLV <input type="checkbox"/> PGV <input type="checkbox"/> PM SLV <input type="checkbox"/> PM PGV 0.0 to 3276.7 A	0	-	A
W26	Magnetic Flux Command Value	<input checked="" type="checkbox"/> V/f <input checked="" type="checkbox"/> DTV <input checked="" type="checkbox"/> PG V/f <input checked="" type="checkbox"/> PG DTV <input type="checkbox"/> SLV <input type="checkbox"/> PGV <input type="checkbox"/> PM SLV <input type="checkbox"/> PM PGV -999 to 999	0	-	%
W27	Timed Operation Remaining Time	<input type="checkbox"/> V/f <input type="checkbox"/> DTV <input type="checkbox"/> PG V/f <input type="checkbox"/> PG DTV <input type="checkbox"/> SLV <input type="checkbox"/> PGV <input type="checkbox"/> PM SLV <input type="checkbox"/> PM PGV 0 to 9999 s	0	-	s
W28	RUN Command Source Monitor	<input type="checkbox"/> V/f <input type="checkbox"/> DTV <input type="checkbox"/> PG V/f <input type="checkbox"/> PG DTV <input type="checkbox"/> SLV <input type="checkbox"/> PGV <input type="checkbox"/> PM SLV <input type="checkbox"/> PM PGV 0 to 23	0	-	-
W29	Frequency and PID Command Source Monitor	<input type="checkbox"/> V/f <input type="checkbox"/> DTV <input type="checkbox"/> PG V/f <input type="checkbox"/> PG DTV <input type="checkbox"/> SLV <input type="checkbox"/> PGV <input type="checkbox"/> PM SLV <input type="checkbox"/> PM PGV 0 to 39	0	-	-
W30	Speed in Percentage	<input type="checkbox"/> V/f <input type="checkbox"/> DTV <input type="checkbox"/> PG V/f <input type="checkbox"/> PG DTV <input type="checkbox"/> SLV <input type="checkbox"/> PGV <input type="checkbox"/> PM SLV <input type="checkbox"/> PM PGV 0.00 to 100.00	0	-	%
W31	Speed Set Value in Percentage	<input type="checkbox"/> V/f <input type="checkbox"/> DTV <input type="checkbox"/> PG V/f <input type="checkbox"/> PG DTV <input type="checkbox"/> SLV <input type="checkbox"/> PGV <input type="checkbox"/> PM SLV <input type="checkbox"/> PM PGV 0.00 to 100.00	0	-	%

Parameter No.	Function name	Monitor or Data Range	Default data	Setting during RUN	Unit
W32	PID Output Monitor	<input type="checkbox"/> V/f <input type="checkbox"/> DTV <input type="checkbox"/> PG V/f <input type="checkbox"/> PG DTV <input type="checkbox"/> SLV <input type="checkbox"/> PGV <input type="checkbox"/> PM SLV <input type="checkbox"/> PM PGV -150.00 to 150.00	0	-	%
W33	Analog Input Monitor	<input type="checkbox"/> V/f <input type="checkbox"/> DTV <input type="checkbox"/> PG V/f <input type="checkbox"/> PG DTV <input type="checkbox"/> SLV <input type="checkbox"/> PGV <input type="checkbox"/> PM SLV <input type="checkbox"/> PM PGV -9990 to 0.00 to 9990	0	-	-
W40	Input Terminal Monitor	<input type="checkbox"/> V/f <input type="checkbox"/> DTV <input type="checkbox"/> PG V/f <input type="checkbox"/> PG DTV <input type="checkbox"/> SLV <input type="checkbox"/> PGV <input type="checkbox"/> PM SLV <input type="checkbox"/> PM PGV Bit15: --- Bit14: --- Bit13: --- Bit12: EN2 Bit11: EN1 Bit10: --- Bit9: --- Bit8: --- Bit7: --- Bit6: DI5 Bit5: DI4 Bit4: DI3 Bit3: DI2 Bit2: DI1 Bit1: DI7 Bit0: DI6	0	-	-
W41	Output Signal Monitor	<input type="checkbox"/> V/f <input type="checkbox"/> DTV <input type="checkbox"/> PG V/f <input type="checkbox"/> PG DTV <input type="checkbox"/> SLV <input type="checkbox"/> PGV <input type="checkbox"/> PM SLV <input type="checkbox"/> PM PGV Bit15: --- Bit14: --- Bit13: --- Bit12: --- Bit11: --- Bit10: --- Bit9: --- Bit8: RO Bit7: --- Bit6: --- Bit5: --- Bit4: --- Bit3: --- Bit2: --- Bit1: DO2 Bit0: DO1	0	-	-

Parameter No.	Function name	Monitor or Data Range	Default data	Setting during RUN	Unit
W42	Communications Input Signal Monitor	<div style="display: flex; justify-content: space-between; border-bottom: 1px solid black; padding-bottom: 2px;"> <span>V/f</span> <span>DTV</span> <span>PG V/f</span> <span>PG DTV</span> </div> <div style="display: flex; justify-content: space-between; border-bottom: 1px solid black; padding-bottom: 2px;"> <span>SLV</span> <span>PGV</span> <span>PM SLV</span> <span>PM PGV</span> </div> Bit15: RST Bit14: DI7 Bit13: DI6 Bit12: --- Bit11: --- Bit10: --- Bit9: --- Bit8: --- Bit7: --- Bit6: DI5 Bit5: DI4 Bit4: DI3 Bit3: DI2 Bit2: DI1 Bit1: REV Bit0: FWD	0	-	-
W43	Communications Control Output Signal Monitor	<div style="display: flex; justify-content: space-between; border-bottom: 1px solid black; padding-bottom: 2px;"> <span>V/f</span> <span>DTV</span> <span>PG V/f</span> <span>PG DTV</span> </div> <div style="display: flex; justify-content: space-between; border-bottom: 1px solid black; padding-bottom: 2px;"> <span>SLV</span> <span>PGV</span> <span>PM SLV</span> <span>PM PGV</span> </div> Bit15: --- Bit14: --- Bit13: --- Bit12: --- Bit11: --- Bit10: --- Bit9: --- Bit8: RO Bit7: --- Bit6: --- Bit5: --- Bit4: --- Bit3: --- Bit2: --- Bit1: DO2 Bit0: DO1	0	-	-
W44	Input Terminal [AI1] Input Voltage	<div style="display: flex; justify-content: space-between; border-bottom: 1px solid black; padding-bottom: 2px;"> <span>V/f</span> <span>DTV</span> <span>PG V/f</span> <span>PG DTV</span> </div> <div style="display: flex; justify-content: space-between; border-bottom: 1px solid black; padding-bottom: 2px;"> <span>SLV</span> <span>PGV</span> <span>PM SLV</span> <span>PM PGV</span> </div> -12.0 to 12.0	0	-	V
W45	Input Terminal [AI2] All Input Current (All)	<div style="display: flex; justify-content: space-between; border-bottom: 1px solid black; padding-bottom: 2px;"> <span>V/f</span> <span>DTV</span> <span>PG V/f</span> <span>PG DTV</span> </div> <div style="display: flex; justify-content: space-between; border-bottom: 1px solid black; padding-bottom: 2px;"> <span>SLV</span> <span>PGV</span> <span>PM SLV</span> <span>PM PGV</span> </div> 0.0 to 30.0 mA	0	-	mA
W46	Output Terminal [AO] AOV Output Voltage	<div style="display: flex; justify-content: space-between; border-bottom: 1px solid black; padding-bottom: 2px;"> <span>V/f</span> <span>DTV</span> <span>PG V/f</span> <span>PG DTV</span> </div> <div style="display: flex; justify-content: space-between; border-bottom: 1px solid black; padding-bottom: 2px;"> <span>SLV</span> <span>PGV</span> <span>PM SLV</span> <span>PM PGV</span> </div> -0.0 to 12.0 V	0	-	V



Parameter No.	Function name	Monitor or Data Range	Default data	Setting during RUN	Unit
W48	Output Terminal [AO]PO Output Frequency	<input type="button" value="V/f"/> <input type="button" value="DTV"/> <input type="button" value="PG V/f"/> <input type="button" value="PG DTV"/> <input type="button" value="SLV"/> <input type="button" value="PGV"/> <input type="button" value="PM SLV"/> <input type="button" value="PM PGV"/> 0 to 32,000 p/s	0	-	p/s
W49	Input Terminal [AI2] Input Voltage (AIV)	<input type="button" value="V/f"/> <input type="button" value="DTV"/> <input type="button" value="PG V/f"/> <input type="button" value="PG DTV"/> <input type="button" value="SLV"/> <input type="button" value="PGV"/> <input type="button" value="PM SLV"/> <input type="button" value="PM PGV"/> -0.0 to 12.0 V	0	-	V
W50	Output Terminal [AO]AOI Output Current	<input type="button" value="V/f"/> <input type="button" value="DTV"/> <input type="button" value="PG V/f"/> <input type="button" value="PG DTV"/> <input type="button" value="SLV"/> <input type="button" value="PGV"/> <input type="button" value="PM SLV"/> <input type="button" value="PM PGV"/> 0.0 to 30.0 mA 999: Disable	32767	-	mA
W53	Pulse Input (A/B Phase of Ch1 Side)	<input type="button" value="V/f"/> <input type="button" value="DTV"/> <input type="button" value="PG V/f"/> <input type="button" value="PG DTV"/> <input type="button" value="SLV"/> <input type="button" value="PGV"/> <input type="button" value="PM SLV"/> <input type="button" value="PM PGV"/> —	0	-	kp/s
W54	Pulse Input (Z Phase of Ch1 Side)	<input type="button" value="V/f"/> <input type="button" value="DTV"/> <input type="button" value="PG V/f"/> <input type="button" value="PG DTV"/> <input type="button" value="SLV"/> <input type="button" value="PGV"/> <input type="button" value="PM SLV"/> <input type="button" value="PM PGV"/> —	0	-	p/s
W55	Reserved	<input type="button" value="V/f"/> <input type="button" value="DTV"/> <input type="button" value="PG V/f"/> <input type="button" value="PG DTV"/> <input type="button" value="SLV"/> <input type="button" value="PGV"/> <input type="button" value="PM SLV"/> <input type="button" value="PM PGV"/> -327.68 to 327.67	0	-	kp/s
W56	Reserved	<input type="button" value="V/f"/> <input type="button" value="DTV"/> <input type="button" value="PG V/f"/> <input type="button" value="PG DTV"/> <input type="button" value="SLV"/> <input type="button" value="PGV"/> <input type="button" value="PM SLV"/> <input type="button" value="PM PGV"/> 0 to 16,000 p/s	0	-	p/s
W57	Do not use	-	-	-	-
W58	Do not use	-	-	-	-
W59	Do not use	-	-	-	-
W60	Do not use	-	-	-	-
W61	Do not use	-	-	-	-
W62	Do not use	-	-	-	-
W63	Do not use	-	-	-	-
W66	Do not use	-	-	-	-
W67	Cumulative Run Time of Capacitors on Printed Circuit Boards	<input type="button" value="V/f"/> <input type="button" value="DTV"/> <input type="button" value="PG V/f"/> <input type="button" value="PG DTV"/> <input type="button" value="SLV"/> <input type="button" value="PGV"/> <input type="button" value="PM SLV"/> <input type="button" value="PM PGV"/> 0 to 9999 (in 10 hours)	0	-	10 hex
W68	Cumulative Run Time of Cooling Fan	<input type="button" value="V/f"/> <input type="button" value="DTV"/> <input type="button" value="PG V/f"/> <input type="button" value="PG DTV"/> <input type="button" value="SLV"/> <input type="button" value="PGV"/> <input type="button" value="PM SLV"/> <input type="button" value="PM PGV"/> 0 to 9999 (in 10 hours)	0	-	10 hex
W70	Total Power ON Time Monitor	<input type="button" value="V/f"/> <input type="button" value="DTV"/> <input type="button" value="PG V/f"/> <input type="button" value="PG DTV"/> <input type="button" value="SLV"/> <input type="button" value="PGV"/> <input type="button" value="PM SLV"/> <input type="button" value="PM PGV"/> 0 to 655350 hour	0	-	h

Parameter No.	Function name	Monitor or Data Range	Default data	Setting during RUN	Unit
W71	Do not use	-	-	-	-
W72	Internal Air Highest Temperature	<input type="checkbox"/> V/f <input type="checkbox"/> DTV <input type="checkbox"/> PG V/f <input type="checkbox"/> PG DTV <input type="checkbox"/> SLV <input type="checkbox"/> PGV <input type="checkbox"/> PM SLV <input type="checkbox"/> PM PGV -32768 to 32767	0	-	degC
W73	Heat Sink Maximum Temperature	<input type="checkbox"/> V/f <input type="checkbox"/> DTV <input type="checkbox"/> PG V/f <input type="checkbox"/> PG DTV <input type="checkbox"/> SLV <input type="checkbox"/> PGV <input type="checkbox"/> PM SLV <input type="checkbox"/> PM PGV -32768 to 32767	0	-	degC
W74	Maximum Effective Current Value	<input type="checkbox"/> V/f <input type="checkbox"/> DTV <input type="checkbox"/> PG V/f <input type="checkbox"/> PG DTV <input type="checkbox"/> SLV <input type="checkbox"/> PGV <input type="checkbox"/> PM SLV <input type="checkbox"/> PM PGV 0.00 to 9999 A	0	-	A
W75	Main Circuit Capacitor's Capacitor Monitor	<input type="checkbox"/> V/f <input type="checkbox"/> DTV <input type="checkbox"/> PG V/f <input type="checkbox"/> PG DTV <input type="checkbox"/> SLV <input type="checkbox"/> PGV <input type="checkbox"/> PM SLV <input type="checkbox"/> PM PGV 0.00 to 100.0	0	-	%
W76	Cumulative Run Time of Electrolytic Capacitors on PC Board	<input type="checkbox"/> V/f <input type="checkbox"/> DTV <input type="checkbox"/> PG V/f <input type="checkbox"/> PG DTV <input type="checkbox"/> SLV <input type="checkbox"/> PGV <input type="checkbox"/> PM SLV <input type="checkbox"/> PM PGV 0 to 65535 hour	0	-	h
W77	Cumulative Run Time of Cooling Fan	<input type="checkbox"/> V/f <input type="checkbox"/> DTV <input type="checkbox"/> PG V/f <input type="checkbox"/> PG DTV <input type="checkbox"/> SLV <input type="checkbox"/> PGV <input type="checkbox"/> PM SLV <input type="checkbox"/> PM PGV 0 to 65535 hour	0	-	h
W78	Number of Startups	<input type="checkbox"/> V/f <input type="checkbox"/> DTV <input type="checkbox"/> PG V/f <input type="checkbox"/> PG DTV <input type="checkbox"/> SLV <input type="checkbox"/> PGV <input type="checkbox"/> PM SLV <input type="checkbox"/> PM PGV 0 to 65,535	0	-	-
W79	Cumulative Operation Time of Motor	<input type="checkbox"/> V/f <input type="checkbox"/> DTV <input type="checkbox"/> PG V/f <input type="checkbox"/> PG DTV <input type="checkbox"/> SLV <input type="checkbox"/> PGV <input type="checkbox"/> PM SLV <input type="checkbox"/> PM PGV 0 to 65535 hour	0	-	h
W81	Integrated Power Monitor	<input type="checkbox"/> V/f <input type="checkbox"/> DTV <input type="checkbox"/> PG V/f <input type="checkbox"/> PG DTV <input type="checkbox"/> SLV <input type="checkbox"/> PGV <input type="checkbox"/> PM SLV <input type="checkbox"/> PM PGV 0.0 to 999900.0	0	-	kWh
W82	Data Used Integrating Electric Power	<input type="checkbox"/> V/f <input type="checkbox"/> DTV <input type="checkbox"/> PG V/f <input type="checkbox"/> PG DTV <input type="checkbox"/> SLV <input type="checkbox"/> PGV <input type="checkbox"/> PM SLV <input type="checkbox"/> PM PGV 0.0 to 9999	0	-	-
W83	Number of Operator Comm Errors	<input type="checkbox"/> V/f <input type="checkbox"/> DTV <input type="checkbox"/> PG V/f <input type="checkbox"/> PG DTV <input type="checkbox"/> SLV <input type="checkbox"/> PGV <input type="checkbox"/> PM SLV <input type="checkbox"/> PM PGV 0 to 9999	0	-	-

Parameter No.	Function name	Monitor or Data Range	Default data	Setting during RUN	Unit
W84	Contents of Operator Comm error	<div style="display: flex; justify-content: space-between; border: 1px solid black; padding: 2px;"> <span>V/f</span> <span>DTV</span> <span>PG V/f</span> <span>PG DTV</span> </div> <div style="display: flex; justify-content: space-between; border: 1px solid black; padding: 2px;"> <span>SLV</span> <span>PGV</span> <span>PM SLV</span> <span>PM PGV</span> </div> 0 to 127 1: Improper FC [RTU] 2: Improper address (function code error) [RTU] 3: Improper data (range error) [RTU] 7: NAK (link priority ; no right ; write disabled) [RTU] 71: Checksum error ; CRC error 72: Parity error 73: Framing error ; overrun error ; buffer full	0	-	-
W85	Number of RS-485 Errors	<div style="display: flex; justify-content: space-between; border: 1px solid black; padding: 2px;"> <span>V/f</span> <span>DTV</span> <span>PG V/f</span> <span>PG DTV</span> </div> <div style="display: flex; justify-content: space-between; border: 1px solid black; padding: 2px;"> <span>SLV</span> <span>PGV</span> <span>PM SLV</span> <span>PM PGV</span> </div> 0 to 9999	0	-	-
W94	Contents of RS-485 Error	<div style="display: flex; justify-content: space-between; border: 1px solid black; padding: 2px;"> <span>V/f</span> <span>DTV</span> <span>PG V/f</span> <span>PG DTV</span> </div> <div style="display: flex; justify-content: space-between; border: 1px solid black; padding: 2px;"> <span>SLV</span> <span>PGV</span> <span>PM SLV</span> <span>PM PGV</span> </div> 1: Improper FC [RTU] 2: Improper address (function code error) [RTU] 3: Improper data (range error) [RTU] 7: NAK (link priority, no right, write disabled) [RTU] 71: Checksum error, CRC error 72: Parity error 73: Framing error, overrun error, buffer full	0	-	-
W118	Torque Bias Monitor	<div style="display: flex; justify-content: space-between; border: 1px solid black; padding: 2px;"> <span>V/f</span> <span>DTV</span> <span>PG V/f</span> <span>PG DTV</span> </div> <div style="display: flex; justify-content: space-between; border: 1px solid black; padding: 2px;"> <span>SLV</span> <span>PGV</span> <span>PM SLV</span> <span>PM PGV</span> </div> -999 to 999	0	-	%
W131	PIC Control PID Deviation	<div style="display: flex; justify-content: space-between; border: 1px solid black; padding: 2px;"> <span>V/f</span> <span>DTV</span> <span>PG V/f</span> <span>PG DTV</span> </div> <div style="display: flex; justify-content: space-between; border: 1px solid black; padding: 2px;"> <span>SLV</span> <span>PGV</span> <span>PM SLV</span> <span>PM PGV</span> </div> -999.00 to 0.00 to 9990.00	0	-	-
W132	PIC Control PID Deviation	<div style="display: flex; justify-content: space-between; border: 1px solid black; padding: 2px;"> <span>V/f</span> <span>DTV</span> <span>PG V/f</span> <span>PG DTV</span> </div> <div style="display: flex; justify-content: space-between; border: 1px solid black; padding: 2px;"> <span>SLV</span> <span>PGV</span> <span>PM SLV</span> <span>PM PGV</span> </div> -32768 to 32767 -20000 = -100% +20000 = +100%	0	-	-
W135	Input Power Monitor	<div style="display: flex; justify-content: space-between; border: 1px solid black; padding: 2px;"> <span>V/f</span> <span>DTV</span> <span>PG V/f</span> <span>PG DTV</span> </div> <div style="display: flex; justify-content: space-between; border: 1px solid black; padding: 2px;"> <span>SLV</span> <span>PGV</span> <span>PM SLV</span> <span>PM PGV</span> </div> 0.0 to 6553.5 kW	0	-	kW

Parameter No.	Function name	Monitor or Data Range	Default data	Setting during RUN	Unit
W136	Input Terminal [AI1] Input Voltage (AIV)	<input type="checkbox"/> V/f <input type="checkbox"/> DTV <input type="checkbox"/> PG V/f <input type="checkbox"/> PG DTV <input type="checkbox"/> SLV <input type="checkbox"/> PGV <input type="checkbox"/> PM SLV <input type="checkbox"/> PM PGV -1024 to 1023 (1023 = 10.9V)	0	-	-
W137	Input Terminal [AI2] Input Current (AII)	<input type="checkbox"/> V/f <input type="checkbox"/> DTV <input type="checkbox"/> PG V/f <input type="checkbox"/> PG DTV <input type="checkbox"/> SLV <input type="checkbox"/> PGV <input type="checkbox"/> PM SLV <input type="checkbox"/> PM PGV 0 to 1023 (1023 = 23.3mA)	0	-	-
W138	Input Terminal [AI2] Input Voltage (AIV)	<input type="checkbox"/> V/f <input type="checkbox"/> DTV <input type="checkbox"/> PG V/f <input type="checkbox"/> PG DTV <input type="checkbox"/> SLV <input type="checkbox"/> PGV <input type="checkbox"/> PM SLV <input type="checkbox"/> PM PGV 0 to 1023 (1023 = 10.9V)	0	-	-
W139	Pulse Train Frequency Monitor	<input type="checkbox"/> V/f <input type="checkbox"/> DTV <input type="checkbox"/> PG V/f <input type="checkbox"/> PG DTV <input type="checkbox"/> SLV <input type="checkbox"/> PGV <input type="checkbox"/> PM SLV <input type="checkbox"/> PM PGV -163.84 to 163.83 %	0	-	%
W142	Feedback Current Position Monitor (MSB)	<input type="checkbox"/> V/f <input type="checkbox"/> DTV <input type="checkbox"/> PG V/f <input type="checkbox"/> PG DTV <input type="checkbox"/> SLV <input type="checkbox"/> PGV <input type="checkbox"/> PM SLV <input type="checkbox"/> PM PGV -268435455 to 268435455 (MSB: -4096 to 4095, LSB: 0 to 65535)	0	-	-
W143	Feedback Current Position Monitor (LSB)	<input type="checkbox"/> V/f <input type="checkbox"/> DTV <input type="checkbox"/> PG V/f <input type="checkbox"/> PG DTV <input type="checkbox"/> SLV <input type="checkbox"/> PGV <input type="checkbox"/> PM SLV <input type="checkbox"/> PM PGV -268435455 to 268435455 (MSB: -4096 to 4095, LSB: 0 to 65535)	0	-	-
W144	Target Position Monitor (MSB)	<input type="checkbox"/> V/f <input type="checkbox"/> DTV <input type="checkbox"/> PG V/f <input type="checkbox"/> PG DTV <input type="checkbox"/> SLV <input type="checkbox"/> PGV <input type="checkbox"/> PM SLV <input type="checkbox"/> PM PGV -268435455 to 268435455 (MSB: -4096 to 4095, LSB: 0 to 65535)	0	-	-
W145	Target Position Monitor (LSB)	<input type="checkbox"/> V/f <input type="checkbox"/> DTV <input type="checkbox"/> PG V/f <input type="checkbox"/> PG DTV <input type="checkbox"/> SLV <input type="checkbox"/> PGV <input type="checkbox"/> PM SLV <input type="checkbox"/> PM PGV -268435455 to 268435455 (MSB: -4096 to 4095, LSB: 0 to 65535)	0	-	-
W146	Position Deviation Monitor (MSB)	<input type="checkbox"/> V/f <input type="checkbox"/> DTV <input type="checkbox"/> PG V/f <input type="checkbox"/> PG DTV <input type="checkbox"/> SLV <input type="checkbox"/> PGV <input type="checkbox"/> PM SLV <input type="checkbox"/> PM PGV -268435455 to 268435455 (MSB: -4096 to 4095, LSB: 0 to 65535)	0	-	-

Parameter No.	Function name	Monitor or Data Range	Default data	Setting during RUN	Unit
W147	Position Deviation Monitor (LSB)	<div style="display: flex; justify-content: space-between; border: 1px solid black; padding: 2px;"> <span>V/f</span> <span>DTV</span> <span>PG V/f</span> <span>PG DTV</span> </div> <div style="display: flex; justify-content: space-between; border: 1px solid black; padding: 2px;"> <span>SLV</span> <span>PGV</span> <span>PM SLV</span> <span>PM PGV</span> </div> -268435455 to 268435455 (MSB: -4096 to 4095, LSB: 0 to 65535)	0	-	-
W148	Touch Probe 1 Positive Edge (MSB)	<div style="display: flex; justify-content: space-between; border: 1px solid black; padding: 2px;"> <span>V/f</span> <span>DTV</span> <span>PG V/f</span> <span>PG DTV</span> </div> <div style="display: flex; justify-content: space-between; border: 1px solid black; padding: 2px;"> <span>SLV</span> <span>PGV</span> <span>PM SLV</span> <span>PM PGV</span> </div> -268435455 to 268435455 (MSB: -4096 to 4095, LSB: 0 to 65535)	0	-	-
W149	Touch Probe 1 Positive Edge (LSB)	<div style="display: flex; justify-content: space-between; border: 1px solid black; padding: 2px;"> <span>V/f</span> <span>DTV</span> <span>PG V/f</span> <span>PG DTV</span> </div> <div style="display: flex; justify-content: space-between; border: 1px solid black; padding: 2px;"> <span>SLV</span> <span>PGV</span> <span>PM SLV</span> <span>PM PGV</span> </div> -268435455 to 268435455 (MSB: -4096 to 4095, LSB: 0 to 65535)	0	-	-
W150	Touch Probe 2 Positive Edge (MSB)	<div style="display: flex; justify-content: space-between; border: 1px solid black; padding: 2px;"> <span>V/f</span> <span>DTV</span> <span>PG V/f</span> <span>PG DTV</span> </div> <div style="display: flex; justify-content: space-between; border: 1px solid black; padding: 2px;"> <span>SLV</span> <span>PGV</span> <span>PM SLV</span> <span>PM PGV</span> </div> -268435455 to 268435455 (MSB: -4096 to 4095, LSB: 0 to 65535)	0	-	-
W151	Touch Probe 2 Positive Edge (LSB)	<div style="display: flex; justify-content: space-between; border: 1px solid black; padding: 2px;"> <span>V/f</span> <span>DTV</span> <span>PG V/f</span> <span>PG DTV</span> </div> <div style="display: flex; justify-content: space-between; border: 1px solid black; padding: 2px;"> <span>SLV</span> <span>PGV</span> <span>PM SLV</span> <span>PM PGV</span> </div> -268435455 to 268435455 (MSB: -4096 to 4095, LSB: 0 to 65535)	0	-	-
W152	Touch Probe Status	<div style="display: flex; justify-content: space-between; border: 1px solid black; padding: 2px;"> <span>V/f</span> <span>DTV</span> <span>PG V/f</span> <span>PG DTV</span> </div> <div style="display: flex; justify-content: space-between; border: 1px solid black; padding: 2px;"> <span>SLV</span> <span>PGV</span> <span>PM SLV</span> <span>PM PGV</span> </div> Bit15: --- Bit14: --- Bit13: --- Bit12: --- Bit11: --- Bit10: --- Bit9: Touch probe 2 PLc Bit8: Touch probe 2 Enb Bit7: --- Bit6: --- Bit5: --- Bit4: --- Bit3: --- Bit2: --- Bit1: Touch probe 1 PLc Bit0: Touch probe 1 Enb	0	-	-

Parameter No.	Function name	Monitor or Data Range	Default data	Setting during RUN	Unit
W161	Braking Resistor Thermal Monitor	<input type="checkbox"/> V/f <input type="checkbox"/> DTV <input type="checkbox"/> PG V/f <input type="checkbox"/> PG DTV <input type="checkbox"/> SLV <input type="checkbox"/> PGV <input type="checkbox"/> PM SLV <input type="checkbox"/> PM PGV 0.0 to 100.0%	0.0	-	%
W178	Number of Startups	<input type="checkbox"/> V/f <input type="checkbox"/> DTV <input type="checkbox"/> PG V/f <input type="checkbox"/> PG DTV <input type="checkbox"/> SLV <input type="checkbox"/> PGV <input type="checkbox"/> PM SLV <input type="checkbox"/> PM PGV 0.00 to 655.35 (1.00 = 10000 times)	0.00	-	-
W179	Total RUN Time Monitor	<input type="checkbox"/> V/f <input type="checkbox"/> DTV <input type="checkbox"/> PG V/f <input type="checkbox"/> PG DTV <input type="checkbox"/> SLV <input type="checkbox"/> PGV <input type="checkbox"/> PM SLV <input type="checkbox"/> PM PGV 0 to 655350 hour	0	-	h
W180	Tuning Progress	<input type="checkbox"/> V/f <input type="checkbox"/> DTV <input type="checkbox"/> PG V/f <input type="checkbox"/> PG DTV <input type="checkbox"/> SLV <input type="checkbox"/> PGV <input type="checkbox"/> PM SLV <input type="checkbox"/> PM PGV 0 to 100 %	0	-	%
W202	Do not use	-	-	-	-
W203	Do not use	-	-	-	-

### 4-1-3 Parameter z (Alarm Information 1)

Parameter No.	Function name	Monitor or Data Range	Default data	Setting during RUN	Unit
Z00	Second Last Alarm Info. Output Frequency	<input type="checkbox"/> V/f <input type="checkbox"/> DTV <input type="checkbox"/> PG V/f <input type="checkbox"/> PG DTV <input type="checkbox"/> SLV <input type="checkbox"/> PGV <input type="checkbox"/> PM SLV <input type="checkbox"/> PM PGV 0.00 to 655.35 Hz	0	-	Hz
Z01	Second Last Alarm Info. Output Current	<input type="checkbox"/> V/f <input type="checkbox"/> DTV <input type="checkbox"/> PG V/f <input type="checkbox"/> PG DTV <input type="checkbox"/> SLV <input type="checkbox"/> PGV <input type="checkbox"/> PM SLV <input type="checkbox"/> PM PGV 0.00 to 99.99 A	0	-	A
Z02	Second Last Alarm Info. Output Voltage	<input type="checkbox"/> V/f <input type="checkbox"/> DTV <input type="checkbox"/> PG V/f <input type="checkbox"/> PG DTV <input type="checkbox"/> SLV <input type="checkbox"/> PGV <input type="checkbox"/> PM SLV <input type="checkbox"/> PM PGV 0 to 1000 V	0	-	V
Z03	Second Last Alarm Info. Torque Monitor	<input type="checkbox"/> V/f <input type="checkbox"/> DTV <input type="checkbox"/> PG V/f <input type="checkbox"/> PG DTV <input type="checkbox"/> SLV <input type="checkbox"/> PGV <input type="checkbox"/> PM SLV <input type="checkbox"/> PM PGV -999 to 999	0	-	%
Z04	Second Last Alarm Info. Frequency Command	<input type="checkbox"/> V/f <input type="checkbox"/> DTV <input type="checkbox"/> PG V/f <input type="checkbox"/> PG DTV <input type="checkbox"/> SLV <input type="checkbox"/> PGV <input type="checkbox"/> PM SLV <input type="checkbox"/> PM PGV 0.00 to 655.35	0	-	Hz

Parameter No.	Function name	Monitor or Data Range	Default data	Setting during RUN	Unit
Z05	Second Last Alarm Info. Running Status	<div style="display: flex; justify-content: space-between; border: 1px solid black; padding: 2px;"> <span>V/f</span> <span>DTV</span> <span>PG V/f</span> <span>PG DTV</span> </div> <div style="display: flex; justify-content: space-between; border: 1px solid black; padding: 2px;"> <span>SLV</span> <span>PGV</span> <span>PM SLV</span> <span>PM PGV</span> </div> <p>Bit15: BUSY (During function code data writing)            Bit14: -            Bit13: -            Bit12: RL (Communications effective)            Bit11: ALM (Alarm relay)            Bit10: DEC (During deceleration)            Bit9: ACC (During acceleration)            Bit8: IL (During current limiting)            Bit7: VL (During voltage limiting)            Bit6: TL (Torque limiting)            Bit5: NUV (Main circuit DC voltage established)            Bit4: BRK (During braking)            Bit3: INT (Inverter shut down)            Bit2: EXT (During DC braking or during pre-exciting)            Bit1: REV (During reverse operation)            Bit0: FWD (During forward operation)</p>	0	-	-
Z06	Second Last Alarm Info. Cumulative Ope. Time	<div style="display: flex; justify-content: space-between; border: 1px solid black; padding: 2px;"> <span>V/f</span> <span>DTV</span> <span>PG V/f</span> <span>PG DTV</span> </div> <div style="display: flex; justify-content: space-between; border: 1px solid black; padding: 2px;"> <span>SLV</span> <span>PGV</span> <span>PM SLV</span> <span>PM PGV</span> </div> <p>0 to 655,350 hour</p>	0	-	h
Z07	Second Last Alarm Info. Number of Startups	<div style="display: flex; justify-content: space-between; border: 1px solid black; padding: 2px;"> <span>V/f</span> <span>DTV</span> <span>PG V/f</span> <span>PG DTV</span> </div> <div style="display: flex; justify-content: space-between; border: 1px solid black; padding: 2px;"> <span>SLV</span> <span>PGV</span> <span>PM SLV</span> <span>PM PGV</span> </div> <p>0 to 65,535</p>	0	-	-
Z08	Second Last Alarm Info. Main Circuit DC Voltage	<div style="display: flex; justify-content: space-between; border: 1px solid black; padding: 2px;"> <span>V/f</span> <span>DTV</span> <span>PG V/f</span> <span>PG DTV</span> </div> <div style="display: flex; justify-content: space-between; border: 1px solid black; padding: 2px;"> <span>SLV</span> <span>PGV</span> <span>PM SLV</span> <span>PM PGV</span> </div> <p>0.0 to 1,000.0 V</p>	0.0	-	V
Z09	Second Last Alarm Info. Internal Air Temperature	<div style="display: flex; justify-content: space-between; border: 1px solid black; padding: 2px;"> <span>V/f</span> <span>DTV</span> <span>PG V/f</span> <span>PG DTV</span> </div> <div style="display: flex; justify-content: space-between; border: 1px solid black; padding: 2px;"> <span>SLV</span> <span>PGV</span> <span>PM SLV</span> <span>PM PGV</span> </div> <p>-32,768 to 32,767</p>	0	-	degC
Z10	Second Last Alarm Info. Heat Sink Temperature	<div style="display: flex; justify-content: space-between; border: 1px solid black; padding: 2px;"> <span>V/f</span> <span>DTV</span> <span>PG V/f</span> <span>PG DTV</span> </div> <div style="display: flex; justify-content: space-between; border: 1px solid black; padding: 2px;"> <span>SLV</span> <span>PGV</span> <span>PM SLV</span> <span>PM PGV</span> </div> <p>-32,768 to 32,767</p>	0	-	degC

Parameter No.	Function name	Monitor or Data Range	Default data	Setting during RUN	Unit
Z11	Second Last Alarm Info. Input Terminal	<div style="display: flex; justify-content: space-between; border-bottom: 1px solid black; padding-bottom: 2px;"> <span>V/f</span> <span>DTV</span> <span>PG V/f</span> <span>PG DTV</span> </div> <div style="display: flex; justify-content: space-between; border-bottom: 1px solid black; padding-bottom: 2px;"> <span>SLV</span> <span>PGV</span> <span>PM SLV</span> <span>PM PGV</span> </div> Bit15: --- Bit14: --- Bit13: --- Bit12: EN2 Bit11: EN1 Bit10: --- Bit9: --- Bit8: --- Bit7: --- Bit6: DI5 Bit5: DI4 Bit4: DI3 Bit3: DI2 Bit2: DI1 Bit1: DI7 Bit0: DI6	0	-	-
Z12	Second Last Alarm Info. Output Terminal	<div style="display: flex; justify-content: space-between; border-bottom: 1px solid black; padding-bottom: 2px;"> <span>V/f</span> <span>DTV</span> <span>PG V/f</span> <span>PG DTV</span> </div> <div style="display: flex; justify-content: space-between; border-bottom: 1px solid black; padding-bottom: 2px;"> <span>SLV</span> <span>PGV</span> <span>PM SLV</span> <span>PM PGV</span> </div> Bit15: --- Bit14: --- Bit13: --- Bit12: --- Bit11: --- Bit10: --- Bit9: --- Bit8: RO Bit7: --- Bit6: --- Bit5: --- Bit4: --- Bit3: --- Bit2: --- Bit1: DO2 Bit0: DO1	0	-	-



Parameter No.	Function name	Monitor or Data Range	Default data	Setting during RUN	Unit
Z13	Second Last Alarm Info. Input Terminal via Communication	<div style="display: flex; justify-content: space-between; border: 1px solid black; padding: 2px;"> <span>V/f</span> <span>DTV</span> <span>PG V/f</span> <span>PG DTV</span> </div> <div style="display: flex; justify-content: space-between; border: 1px solid black; padding: 2px; margin-top: 2px;"> <span>SLV</span> <span>PGV</span> <span>PM SLV</span> <span>PM PGV</span> </div> <p>Bit15: RST            Bit14: DI7            Bit13: DI6            Bit12: ---            Bit11: ---            Bit10: ---            Bit9: ---            Bit8: ---            Bit7: ---            Bit6: DI5            Bit5: DI4            Bit4: DI3            Bit3: DI2            Bit2: DI1            Bit1: REV            Bit0: FWD</p>	0	-	-
Z14	Second Last Alarm Info. Output Terminal via Communication	<div style="display: flex; justify-content: space-between; border: 1px solid black; padding: 2px;"> <span>V/f</span> <span>DTV</span> <span>PG V/f</span> <span>PG DTV</span> </div> <div style="display: flex; justify-content: space-between; border: 1px solid black; padding: 2px; margin-top: 2px;"> <span>SLV</span> <span>PGV</span> <span>PM SLV</span> <span>PM PGV</span> </div> <p>Bit15: ---            Bit14: ---            Bit13: ---            Bit12: ---            Bit11: ---            Bit10: ---            Bit9: ---            Bit8: RO            Bit7: ---            Bit6: ---            Bit5: ---            Bit4: ---            Bit3: ---            Bit2: ---            Bit1: DO2            Bit0: DO1</p>	0	-	-

Parameter No.	Function name	Monitor or Data Range	Default data	Setting during RUN	Unit
Z16	Second Last Alarm Info. Running Status 2	<div style="display: flex; justify-content: space-between; border-bottom: 1px solid black; margin-bottom: 5px;"> <span>V/f</span> <span>DTV</span> <span>PG V/f</span> <span>PG DTV</span> </div> <div style="display: flex; justify-content: space-between; border-bottom: 1px solid black; margin-bottom: 5px;"> <span>SLV</span> <span>PGV</span> <span>PM SLV</span> <span>PM PGV</span> </div> Bit15: Motor type 1: PM motor 0: Induction motor Bit14: During EN circuit diagnosis Bit7: During speed control (1 during control) Bit5 to 4: Selected motor 00: 1st motor 01: 2nd motor 10: Reserved 11: Reserved Bit3 to 0: Control method 0000: V/f control without slip compensation 0001: Dynamic torque vector control 0010: V/f control with slip compensation 0011: V/f control with speed sensor 0100: Dynamic torque vector control with speed sensor 0101: Vector control without speed sensor 0110: Vector control with speed sensor 0111: Torque control (Vector control without speed sensor) 1000: Torque control (Vector control with speed sensor)	0	-	-
Z17	Second Last Alarm Info. Speed Detection	<div style="display: flex; justify-content: space-between; border-bottom: 1px solid black; margin-bottom: 5px;"> <span>V/f</span> <span>DTV</span> <span>PG V/f</span> <span>PG DTV</span> </div> <div style="display: flex; justify-content: space-between; border-bottom: 1px solid black; margin-bottom: 5px;"> <span>SLV</span> <span>PGV</span> <span>PM SLV</span> <span>PM PGV</span> </div> -32,768 to 32,767	0	-	-

Parameter No.	Function name	Monitor or Data Range	Default data	Setting during RUN	Unit
Z18	Second Last Alarm Info. Running Status 3	<div style="display: flex; justify-content: space-between; border: 1px solid black; padding: 2px;"> <span>V/f</span> <span>DTV</span> <span>PG V/f</span> <span>PG DTV</span> </div> <div style="display: flex; justify-content: space-between; border: 1px solid black; padding: 2px;"> <span>SLV</span> <span>PGV</span> <span>PM SLV</span> <span>PM PGV</span> </div> <p>Bit15: ---            Bit14: OL (Overload warning)            Bit13: LOC (Light load detection)            Bit12: OL2 (Overload warning 2)            Bit11: OLP (During active drive)            Bit10: LIFE (Life warning)            Bit9: OHF (Fin Overheat warning)            Bit8: TRY (During retry)            Bit7: FAN (Fan operation signal)            Bit6: REF (RUN command source)            Bit5: THM (Thermal warning)            Bit4: IPF (During restart after instantaneous power failure)            Bit3: SETM (2nd motor selection)            Bit2: IRDY (Operation ready)            Bit1: FDT1 (Over set Frequency arrival)            Bit0: FAR1 (Constant speed arrival)</p>	0	-	-
Z40	1st Cumulative Run Time	<div style="display: flex; justify-content: space-between; border: 1px solid black; padding: 2px;"> <span>V/f</span> <span>DTV</span> <span>PG V/f</span> <span>PG DTV</span> </div> <div style="display: flex; justify-content: space-between; border: 1px solid black; padding: 2px;"> <span>SLV</span> <span>PGV</span> <span>PM SLV</span> <span>PM PGV</span> </div> <p>0 to 65,535 (in 10 hours)</p>	0	-	10 hex
Z41	2nd Cumulative Run Time of motor	<div style="display: flex; justify-content: space-between; border: 1px solid black; padding: 2px;"> <span>V/f</span> <span>DTV</span> <span>PG V/f</span> <span>PG DTV</span> </div> <div style="display: flex; justify-content: space-between; border: 1px solid black; padding: 2px;"> <span>SLV</span> <span>PGV</span> <span>PM SLV</span> <span>PM PGV</span> </div> <p>0 to 65,535 (in 10 hours)</p>	0	-	10 hex
Z44	2nd Number of Startups	<div style="display: flex; justify-content: space-between; border: 1px solid black; padding: 2px;"> <span>V/f</span> <span>DTV</span> <span>PG V/f</span> <span>PG DTV</span> </div> <div style="display: flex; justify-content: space-between; border: 1px solid black; padding: 2px;"> <span>SLV</span> <span>PGV</span> <span>PM SLV</span> <span>PM PGV</span> </div> <p>0 to 65,535</p>	0	-	-
Z50	Third Last Alarm Info. Output Frequency	<div style="display: flex; justify-content: space-between; border: 1px solid black; padding: 2px;"> <span>V/f</span> <span>DTV</span> <span>PG V/f</span> <span>PG DTV</span> </div> <div style="display: flex; justify-content: space-between; border: 1px solid black; padding: 2px;"> <span>SLV</span> <span>PGV</span> <span>PM SLV</span> <span>PM PGV</span> </div> <p>0.00 to 655.35 Hz</p>	0	-	Hz
Z51	Third Last Alarm Info. Output Current	<div style="display: flex; justify-content: space-between; border: 1px solid black; padding: 2px;"> <span>V/f</span> <span>DTV</span> <span>PG V/f</span> <span>PG DTV</span> </div> <div style="display: flex; justify-content: space-between; border: 1px solid black; padding: 2px;"> <span>SLV</span> <span>PGV</span> <span>PM SLV</span> <span>PM PGV</span> </div> <p>0.00 to 99.99 A</p>	0	-	A

Parameter No.	Function name	Monitor or Data Range	Default data	Setting during RUN	Unit
Z52	Third Last Alarm Info. Output Voltage	<div style="display: flex; justify-content: space-between; border-bottom: 1px solid black; margin-bottom: 5px;"> <span>V/f</span> <span>DTV</span> <span>PG V/f</span> <span>PG DTV</span> </div> <div style="display: flex; justify-content: space-between; border-bottom: 1px solid black; margin-bottom: 5px;"> <span>SLV</span> <span>PGV</span> <span>PM SLV</span> <span>PM PGV</span> </div> 0 to 1000 V	0	-	V
Z53	Third Last Alarm Info. Torque Monitor	<div style="display: flex; justify-content: space-between; border-bottom: 1px solid black; margin-bottom: 5px;"> <span>V/f</span> <span>DTV</span> <span>PG V/f</span> <span>PG DTV</span> </div> <div style="display: flex; justify-content: space-between; border-bottom: 1px solid black; margin-bottom: 5px;"> <span>SLV</span> <span>PGV</span> <span>PM SLV</span> <span>PM PGV</span> </div> -999 to 999	0	-	%
Z54	Third Last Alarm Info. Frequency Command	<div style="display: flex; justify-content: space-between; border-bottom: 1px solid black; margin-bottom: 5px;"> <span>V/f</span> <span>DTV</span> <span>PG V/f</span> <span>PG DTV</span> </div> <div style="display: flex; justify-content: space-between; border-bottom: 1px solid black; margin-bottom: 5px;"> <span>SLV</span> <span>PGV</span> <span>PM SLV</span> <span>PM PGV</span> </div> 0.00 to 655.35	0	-	Hz
Z55	Third Last Alarm Info. Running Status	<div style="display: flex; justify-content: space-between; border-bottom: 1px solid black; margin-bottom: 5px;"> <span>V/f</span> <span>DTV</span> <span>PG V/f</span> <span>PG DTV</span> </div> <div style="display: flex; justify-content: space-between; border-bottom: 1px solid black; margin-bottom: 5px;"> <span>SLV</span> <span>PGV</span> <span>PM SLV</span> <span>PM PGV</span> </div> Bit15: BUSY (During function code data writing) Bit14: - Bit13: - Bit12: RL (Communications effective) Bit11: ALM (Alarm relay) Bit10: DEC (During deceleration) Bit9: ACC (During acceleration) Bit8: IL (During current limiting) Bit7: VL (During voltage limiting) Bit6: TL (Torque limiting) Bit5: NUV (Main circuit DC voltage established) Bit4: BRK (During braking) Bit3: INT (Inverter shut down) Bit2: EXT (During DC braking or during pre-exciting) Bit1: REV (During reverse operation) Bit0: FWD (During forward operation)	0	-	-
Z56	Third Last Alarm Info. Cumulative Ope. Time	<div style="display: flex; justify-content: space-between; border-bottom: 1px solid black; margin-bottom: 5px;"> <span>V/f</span> <span>DTV</span> <span>PG V/f</span> <span>PG DTV</span> </div> <div style="display: flex; justify-content: space-between; border-bottom: 1px solid black; margin-bottom: 5px;"> <span>SLV</span> <span>PGV</span> <span>PM SLV</span> <span>PM PGV</span> </div> 0 to 655350 hour	0	-	h
Z57	Third Last Alarm Info. Number of Startups	<div style="display: flex; justify-content: space-between; border-bottom: 1px solid black; margin-bottom: 5px;"> <span>V/f</span> <span>DTV</span> <span>PG V/f</span> <span>PG DTV</span> </div> <div style="display: flex; justify-content: space-between; border-bottom: 1px solid black; margin-bottom: 5px;"> <span>SLV</span> <span>PGV</span> <span>PM SLV</span> <span>PM PGV</span> </div> 0 to 65,535	0	-	-

Parameter No.	Function name	Monitor or Data Range	Default data	Setting during RUN	Unit
Z58	Third Last Alarm Info. Main Circuit DC Voltage	<div style="display: flex; justify-content: space-between; border: 1px solid black; padding: 2px;"> <span>V/f</span> <span>DTV</span> <span>PG V/f</span> <span>PG DTV</span> </div> <div style="display: flex; justify-content: space-between; border: 1px solid black; padding: 2px;"> <span>SLV</span> <span>PGV</span> <span>PM SLV</span> <span>PM PGV</span> </div> 0.0 to 1,000.0 V	0.0	-	V
Z59	Third Last Alarm Info. Internal Air Temperature	<div style="display: flex; justify-content: space-between; border: 1px solid black; padding: 2px;"> <span>V/f</span> <span>DTV</span> <span>PG V/f</span> <span>PG DTV</span> </div> <div style="display: flex; justify-content: space-between; border: 1px solid black; padding: 2px;"> <span>SLV</span> <span>PGV</span> <span>PM SLV</span> <span>PM PGV</span> </div> -32768 to 32767	0	-	degC
Z60	Third Last Alarm Info. Heat Sink Temperature	<div style="display: flex; justify-content: space-between; border: 1px solid black; padding: 2px;"> <span>V/f</span> <span>DTV</span> <span>PG V/f</span> <span>PG DTV</span> </div> <div style="display: flex; justify-content: space-between; border: 1px solid black; padding: 2px;"> <span>SLV</span> <span>PGV</span> <span>PM SLV</span> <span>PM PGV</span> </div> -32,768 to 32,767	0	-	degC
Z61	Third Last Alarm Info. Input Terminal	<div style="display: flex; justify-content: space-between; border: 1px solid black; padding: 2px;"> <span>V/f</span> <span>DTV</span> <span>PG V/f</span> <span>PG DTV</span> </div> <div style="display: flex; justify-content: space-between; border: 1px solid black; padding: 2px;"> <span>SLV</span> <span>PGV</span> <span>PM SLV</span> <span>PM PGV</span> </div> Bit15: --- Bit14: --- Bit13: --- Bit12: EN2 Bit11: EN1 Bit10: --- Bit9: --- Bit8: --- Bit7: --- Bit6: DI5 Bit5: DI4 Bit4: DI3 Bit3: DI2 Bit2: DI1 Bit1: DI7 Bit0: DI6	0	-	-
Z62	Third Last Alarm Info. Output Terminal	<div style="display: flex; justify-content: space-between; border: 1px solid black; padding: 2px;"> <span>V/f</span> <span>DTV</span> <span>PG V/f</span> <span>PG DTV</span> </div> <div style="display: flex; justify-content: space-between; border: 1px solid black; padding: 2px;"> <span>SLV</span> <span>PGV</span> <span>PM SLV</span> <span>PM PGV</span> </div> Bit15: --- Bit14: --- Bit13: --- Bit12: --- Bit11: --- Bit10: --- Bit9: --- Bit8: RO Bit7: --- Bit6: --- Bit5: --- Bit4: --- Bit3: --- Bit2: --- Bit1: DO2 Bit0: DO1	0	-	-

Parameter No.	Function name	Monitor or Data Range	Default data	Setting during RUN	Unit
Z63	Third Last Alarm Info. Input Terminal via Communication	<div style="display: flex; justify-content: space-between; border-bottom: 1px solid black; padding-bottom: 2px;"> <span>V/f</span> <span>DTV</span> <span>PG V/f</span> <span>PG DTV</span> </div> <div style="display: flex; justify-content: space-between; border-bottom: 1px solid black; padding-bottom: 2px;"> <span>SLV</span> <span>PGV</span> <span>PM SLV</span> <span>PM PGV</span> </div> Bit15: RST Bit14: DI7 Bit13: DI6 Bit12: --- Bit11: --- Bit10: --- Bit9: --- Bit8: --- Bit7: --- Bit6: DI5 Bit5: DI4 Bit4: DI3 Bit3: DI2 Bit2: DI1 Bit1: REV Bit0: FWD	0	-	-
Z64	Third Last Alarm Info. Output Terminal via Communication	<div style="display: flex; justify-content: space-between; border-bottom: 1px solid black; padding-bottom: 2px;"> <span>V/f</span> <span>DTV</span> <span>PG V/f</span> <span>PG DTV</span> </div> <div style="display: flex; justify-content: space-between; border-bottom: 1px solid black; padding-bottom: 2px;"> <span>SLV</span> <span>PGV</span> <span>PM SLV</span> <span>PM PGV</span> </div> Bit15: --- Bit14: --- Bit13: --- Bit12: --- Bit11: --- Bit10: --- Bit9: --- Bit8: RO Bit7: --- Bit6: --- Bit5: --- Bit4: --- Bit3: --- Bit2: --- Bit1: DO2 Bit0: DO1	0	-	-

Parameter No.	Function name	Monitor or Data Range	Default data	Setting during RUN	Unit
Z66	Third Last Alarm Info. Running Status 2	<div style="display: flex; justify-content: space-between; border: 1px solid black; padding: 2px;"> <span>V/f</span> <span>DTV</span> <span>PG V/f</span> <span>PG DTV</span> </div> <div style="display: flex; justify-content: space-between; border: 1px solid black; padding: 2px; margin-top: 2px;"> <span>SLV</span> <span>PGV</span> <span>PM SLV</span> <span>PM PGV</span> </div> <p>Bit15: Motor type            1: PM motor            0: Induction motor            Bit14: During EN circuit diagnosis            Bit7: During speed control (1 during control)            Bit5 to 4: Selected motor            00: 1st motor            01: 2nd motor            10: Reserved            11: Reserved            Bit3 to 0: Control method            0000: V/f control without slip compensation            0001: Dynamic torque vector control            0010: V/f control with slip compensation            0011: V/f control with speed sensor            0100: Dynamic torque vector control with speed sensor            0101: Vector control without speed sensor            0110: Vector control with speed sensor            0111: Torque control (Vector control without speed sensor)            1000: Torque control (Vector control with speed sensor)</p>	0	-	-
Z67	Third Last Alarm Info. Speed Detection	<div style="display: flex; justify-content: space-between; border: 1px solid black; padding: 2px;"> <span>V/f</span> <span>DTV</span> <span>PG V/f</span> <span>PG DTV</span> </div> <div style="display: flex; justify-content: space-between; border: 1px solid black; padding: 2px; margin-top: 2px;"> <span>SLV</span> <span>PGV</span> <span>PM SLV</span> <span>PM PGV</span> </div> <p>-32768 to 32767</p>	0	-	-

Parameter No.	Function name	Monitor or Data Range	Default data	Setting during RUN	Unit
Z68	Third Last Alarm Info. Running Status 3	<div style="display: flex; justify-content: space-between; border-bottom: 1px solid black; margin-bottom: 5px;"> <span>V/f</span> <span>DTV</span> <span>PG V/f</span> <span>PG DTV</span> </div> <div style="display: flex; justify-content: space-between; border-bottom: 1px solid black; margin-bottom: 5px;"> <span>SLV</span> <span>PGV</span> <span>PM SLV</span> <span>PM PGV</span> </div> Bit15: --- Bit14: OL (Overload warning) Bit13: LOC (Light load detection) Bit12: OL2 (Overload warning 2) Bit11: OLP (During active drive) Bit10: LIFE (Life warning) Bit9: OHF (Fin Overheat warning) Bit8: TRY (During retry) Bit7: FAN (Fan operation signal) Bit6: REF (RUN command source) Bit5: THM (Thermal warning) Bit4: IPF (During restart after instantaneous power failure) Bit3: SETM (2nd motor selection) Bit2: IRDY (Operation ready) Bit1: FDT1 (Over set Frequency arrival) Bit0: FAR1 (Constant speed arrival)	0	-	-
Z84	Output Current Monitor	<div style="display: flex; justify-content: space-between; border-bottom: 1px solid black; margin-bottom: 5px;"> <span>V/f</span> <span>DTV</span> <span>PG V/f</span> <span>PG DTV</span> </div> <div style="display: flex; justify-content: space-between; border-bottom: 1px solid black; margin-bottom: 5px;"> <span>SLV</span> <span>PGV</span> <span>PM SLV</span> <span>PM PGV</span> </div> 0.00 to 99.99 A	0	-	A

#### 4-1-4 Parameter X (Alarm Information 2)

Parameter No.	Function name	Monitor or Data Range	Default data	Setting during RUN	Unit
X01	Latest Multiple Alarm1	<div style="display: flex; justify-content: space-between; border-bottom: 1px solid black; margin-bottom: 5px;"> <span>V/f</span> <span>DTV</span> <span>PG V/f</span> <span>PG DTV</span> </div> <div style="display: flex; justify-content: space-between; border-bottom: 1px solid black; margin-bottom: 5px;"> <span>SLV</span> <span>PGV</span> <span>PM SLV</span> <span>PM PGV</span> </div> 0000 to FFFF Hex	0	-	-
X02	Latest Multiple Alarm2	<div style="display: flex; justify-content: space-between; border-bottom: 1px solid black; margin-bottom: 5px;"> <span>V/f</span> <span>DTV</span> <span>PG V/f</span> <span>PG DTV</span> </div> <div style="display: flex; justify-content: space-between; border-bottom: 1px solid black; margin-bottom: 5px;"> <span>SLV</span> <span>PGV</span> <span>PM SLV</span> <span>PM PGV</span> </div> 0000 to FFFF Hex	0	-	-
X03	Latest Alarm Sub Code 1	<div style="display: flex; justify-content: space-between; border-bottom: 1px solid black; margin-bottom: 5px;"> <span>V/f</span> <span>DTV</span> <span>PG V/f</span> <span>PG DTV</span> </div> <div style="display: flex; justify-content: space-between; border-bottom: 1px solid black; margin-bottom: 5px;"> <span>SLV</span> <span>PGV</span> <span>PM SLV</span> <span>PM PGV</span> </div> 0 to 9999	0	-	-



Parameter No.	Function name	Monitor or Data Range	Default data	Setting during RUN	Unit
X04	Latest Multiple Alarm Sub Code 2	<div style="display: flex; justify-content: space-between; border: 1px solid black; padding: 2px;"> <span>V/f</span> <span>DTV</span> <span>PG V/f</span> <span>PG DTV</span> </div> <div style="display: flex; justify-content: space-between; border: 1px solid black; padding: 2px;"> <span>SLV</span> <span>PGV</span> <span>PM SLV</span> <span>PM PGV</span> </div> <p>0 to 9999</p>	0	-	-
X05	Last Alarm History/Number of Consecutive Same Alarms	<div style="display: flex; justify-content: space-between; border: 1px solid black; padding: 2px;"> <span>V/f</span> <span>DTV</span> <span>PG V/f</span> <span>PG DTV</span> </div> <div style="display: flex; justify-content: space-between; border: 1px solid black; padding: 2px;"> <span>SLV</span> <span>PGV</span> <span>PM SLV</span> <span>PM PGV</span> </div> <p>0000 to FFFF hex (MSB: 00 to FF hex, LSB:00 to FE hex) MSB: Number of alarm</p> <p>LSB: 00 to FE hex 00 hex (0) : No alarm 01 hex (1) : OC1 Overcurrent protection (during acceleration) 02 hex (2) : OC2 Overcurrent protection (during deceleration) 03 hex (3) : OC3 Overcurrent protection (during constant speed operation) 06 hex (4) : OU1 Overvoltage protection (during acceleration) 07 hex (7) : OU2 Overvoltage protection (during deceleration) 08 hex (8) : OU3 Overvoltage protection (during constant speed operation or stopping) 0A hex (10) : LU Undervoltage protection 0B hex (11) : Lin Input phase loss protection 10 hex (16) : PbF Inrush current avoidance circuit error 11 hex (17) : OH1 Heat sink overheat 12 hex (18) : OH2 External alarm input 13 hex (19) : OH3 Inverter internal overheat 14 hex (20) : OH4 Motor protection (PTC thermistor) 16 hex (22) : dbH Braking resistor overheat 17 hex (23) : OL1 Motor 1 overload 18 hex (24) : OL2 Motor 2 overload</p>	0	-	-

Parameter No.	Function name	Monitor or Data Range	Default data	Setting during RUN	Unit
X05	Last Alarm History/Number of Consecutive Same Alarms	19 hex (25) : OLU Inverter overload 1B hex (27) : OS Over speed protection 1C hex (28) : Pg PG disconnection 1F hex (31) : Er1 Memory error 20 hex (32) : Er2 Operator communications 23 hex (35) : Er5 Option card error 24 hex (36) : Er6 Operation protection 25 hex (37) : Er7 Tuning error 2A hex (42) : Erd Detection of step-out 2E hex (46) : OPL Output phase loss protection 2F hex (47) : ErE Following error (excessive speed deviation) 32 hex (50) : ErC Magnetic pole position detection error 33 hex (51) : ErF Data save error in case of undervoltage 34 hex (52) : d0 Excessive positioning deviation 35 hex (53) : ErP (RS-485 communications error, Option card) 38 hex (56) : Ero Position control error 39 hex (57) : ECF EN circuit failure 3A hex (58) : CoF PID feedback disconnection detected 3B hex (59) : dbA Braking resistor overheat 44 hex (68) : ErU Support tool communication disconnection 46 hex (70) : OH6 Inrush current prevention resistor overheat FD hex (253) : Lok Locked by password FE hex (254) : Err Mock alarm (Subcode = 9998)	0	-	-
X06	Last Multiple Alarm 2	<div style="display: flex; justify-content: space-between; border: 1px solid black; padding: 2px;"> <span>V/f</span> <span>DTV</span> <span>PG V/f</span> <span>PG DTV</span> </div> <div style="display: flex; justify-content: space-between; border: 1px solid black; padding: 2px; margin-top: 2px;"> <span>SLV</span> <span>PGV</span> <span>PM SLV</span> <span>PM PGV</span> </div> 0000 to FFFF Hex	0	-	-

Parameter No.	Function name	Monitor or Data Range	Default data	Setting during RUN	Unit
X07	Last Multiple Alarm 3	<div style="display: flex; justify-content: space-between; border: 1px solid black; padding: 2px;"> <span>V/f</span> <span>DTV</span> <span>PG V/f</span> <span>PG DTV</span> </div> <div style="display: flex; justify-content: space-between; border: 1px solid black; padding: 2px;"> <span>SLV</span> <span>PGV</span> <span>PM SLV</span> <span>PM PGV</span> </div> 0000 to FFFF Hex	0	-	-
X08	Last Alarm Sub Code 1	<div style="display: flex; justify-content: space-between; border: 1px solid black; padding: 2px;"> <span>V/f</span> <span>DTV</span> <span>PG V/f</span> <span>PG DTV</span> </div> <div style="display: flex; justify-content: space-between; border: 1px solid black; padding: 2px;"> <span>SLV</span> <span>PGV</span> <span>PM SLV</span> <span>PM PGV</span> </div> 0 to 9999	0	-	-
X09	Last Multiple Alarm Sub Code	<div style="display: flex; justify-content: space-between; border: 1px solid black; padding: 2px;"> <span>V/f</span> <span>DTV</span> <span>PG V/f</span> <span>PG DTV</span> </div> <div style="display: flex; justify-content: space-between; border: 1px solid black; padding: 2px;"> <span>SLV</span> <span>PGV</span> <span>PM SLV</span> <span>PM PGV</span> </div> 0 to 9999	0	-	-
X10	Second Last Alarm History/ Number of Consecutive Same Alarms	<div style="display: flex; justify-content: space-between; border: 1px solid black; padding: 2px;"> <span>V/f</span> <span>DTV</span> <span>PG V/f</span> <span>PG DTV</span> </div> <div style="display: flex; justify-content: space-between; border: 1px solid black; padding: 2px;"> <span>SLV</span> <span>PGV</span> <span>PM SLV</span> <span>PM PGV</span> </div> 0000 to FFFF hex (MSB: 00 to FF hex, LSB:00 to FE hex) MSB: Number of alarm  LSB: 00 to FE hex 00 hex (0) : No alarm 01 hex (1) : OC1 Overcurrent protection (during acceleration) 02 hex (2) : OC2 Overcurrent protection (during deceleration) 03 hex (3) : OC3 Overcurrent protection (during constant speed operation) 06 hex (4) : OU1 Overvoltage protection (during acceleration) 07 hex (7) : OU2 Overvoltage protection (during deceleration) 08 hex (8) : OU3 Overvoltage protection (during constant speed operation or stopping) 0A hex (10) : LU Undervoltage protection	0	-	-

Parameter No.	Function name	Monitor or Data Range	Default data	Setting during RUN	Unit
X10	Second Last Alarm History/ Number of Consecutive Same Alarms	0B hex (11) : Lin Input phase loss protection 10 hex (16) : PbF Inrush current avoidance circuit error 11 hex (17) : OH1 Heat sink overheat 12 hex (18) : OH2 External alarm input 13 hex (19) : OH3 Inverter internal overheat 14 hex (20) : OH4 Motor protection (PTC thermistor) 16 hex (22) : dbH Braking resistor overheat 17 hex (23) : OL1 Motor 1 overload 18 hex (24) : OL2 Motor 2 overload 19 hex (25) : OLU Inverter overload 1B hex (27) : OS Over speed protection 1C hex (28) : Pg PG disconnection 1F hex (31) : Er1 Memory error 20 hex (32) : Er2 Operator communications 23 hex (35) : Er5 Option card error 24 hex (36) : Er6 Operation protection 25 hex (37) : Er7 Tuning error 2A hex (42) : Erd Detection of step-out 2E hex (46) : OPL Output phase loss protection 2F hex (47) : ErE Following error (excessive speed deviation)	0	-	-

Parameter No.	Function name	Monitor or Data Range	Default data	Setting during RUN	Unit
X10	Second Last Alarm History/ Number of Consecutive Same Alarms	32 hex (50) : ErC Magnetic pole position detection error 33 hex (51) : ErF Data save error in case of undervoltage 34 hex (52) : d0 Excessive positioning deviation 35 hex (53) : ErP (RS-485 communications error, Option card) 38 hex (56) : Ero Position control error 39 hex (57) : ECF EN circuit failure 3A hex (58) : CoF PID feedback disconnection detected 3B hex (59) : dbA Braking resistor overheat 44 hex (68) : ErU Support tool communication disconnection 46 hex (70) : OH6 Inrush current prevention resistor overheat FD hex (253) : Lok Locked by password FE hex (254) : Err Mock alarm (Subcode = 9998)	0	-	-
X11	Second last Multiple Alarm2	<input type="checkbox"/> V/f <input type="checkbox"/> DTV <input type="checkbox"/> PG V/f <input type="checkbox"/> PG DTV <input type="checkbox"/> SLV <input type="checkbox"/> PGV <input type="checkbox"/> PM SLV <input type="checkbox"/> PM PGV 0000 to FFFF Hex	0	-	-
X12	Second Last Multiple Alarm3	<input type="checkbox"/> V/f <input type="checkbox"/> DTV <input type="checkbox"/> PG V/f <input type="checkbox"/> PG DTV <input type="checkbox"/> SLV <input type="checkbox"/> PGV <input type="checkbox"/> PM SLV <input type="checkbox"/> PM PGV 0000 to FFFF Hex	0	-	-
X13	Second Last Alarm Sub Code	<input type="checkbox"/> V/f <input type="checkbox"/> DTV <input type="checkbox"/> PG V/f <input type="checkbox"/> PG DTV <input type="checkbox"/> SLV <input type="checkbox"/> PGV <input type="checkbox"/> PM SLV <input type="checkbox"/> PM PGV 0 to 9999	0	-	-
X14	Second Last Multiple Alarm Sub Code	<input type="checkbox"/> V/f <input type="checkbox"/> DTV <input type="checkbox"/> PG V/f <input type="checkbox"/> PG DTV <input type="checkbox"/> SLV <input type="checkbox"/> PGV <input type="checkbox"/> PM SLV <input type="checkbox"/> PM PGV 0 to 9999	0	-	-

Parameter No.	Function name	Monitor or Data Range	Default data	Setting during RUN	Unit
X15	Third Last Alarm History/Number of Consecutive Same Alarms	<p>V/f   DTV   PG V/f   PG DTV</p> <p>SLV   PGV   PM SLV   PM PGV</p> <p>0000 to FFFF hex (MSB: 00 to FF hex, LSB:00 to FE hex) MSB: Number of alarm</p> <p>LSB: 00 to FE hex 00 hex (0) : No alarm 01 hex (1) : OC1 Overcurrent protection (during acceleration) 02 hex (2) : OC2 Overcurrent protection (during deceleration) 03 hex (3) : OC3 Overcurrent protection (during constant speed operation) 06 hex (4) : OU1 Overvoltage protection (during acceleration) 07 hex (7) : OU2 Overvoltage protection (during deceleration) 08 hex (8) : OU3 Overvoltage protection (during constant speed operation or stopping) 0A hex (10) : LU Undervoltage protection 0B hex (11) : Lin Input phase loss protection 10 hex (16) : PbF Inrush current avoidance circuit error 11 hex (17) : OH1 Heat sink overheat 12 hex (18) : OH2 External alarm input 13 hex (19) : OH3 Inverter internal overheat 14 hex (20) : OH4 Motor protection (PTC thermistor) 16 hex (22) : dbH Braking resistor overheat 17 hex (23) : OL1 Motor 1 overload 18 hex (24) : OL2 Motor 2 overload 19 hex (25) : OLU Inverter overload</p>	0	-	-

Parameter No.	Function name	Monitor or Data Range	Default data	Setting during RUN	Unit
X15	Third Last Alarm History/Number of Consecutive Same Alarms	1B hex (27) : OS Over speed protection 1C hex (28) : Pg PG disconnection 1F hex (31) : Er1 Memory error 20 hex (32) : Er2 Operator communications 23 hex (35) : Er5 Option card error 24 hex (36) : Er6 Operation protection 25 hex (37) : Er7 Tuning error 2A hex (42) : Erd Detection of step-out 2E hex (46) : OPL Output phase loss protection 2F hex (47) : ErE Following error (excessive speed deviation) 32 hex (50) : ErC Magnetic pole position detection error 33 hex (51) : ErF Data save error in case of undervoltage 34 hex (52) : d0 Excessive positioning deviation 35 hex (53) : ErP (RS-485 communications error, Option card) 38 hex (56) : Ero Position control error 39 hex (57) : ECF EN circuit failure 3A hex (58) : CoF PID feedback disconnection detected 3B hex (59) : dbA Braking resistor overheat 44 hex (68) : ErU Support tool communication disconnection 46 hex (70) : OH6 Inrush current prevention resistor overheat FD hex (253) : Lok Locked by password FE hex (254) : Err Mock alarm (Subcode = 9998)	0	-	-
X16	Third Last Multiple Alarm 2	<div style="border: 1px solid black; padding: 2px; display: inline-block; margin-bottom: 5px;">V/f</div> <div style="border: 1px solid black; padding: 2px; display: inline-block; margin-bottom: 5px;">DTV</div> <div style="border: 1px solid black; padding: 2px; display: inline-block; margin-bottom: 5px;">PG V/f</div> <div style="border: 1px solid black; padding: 2px; display: inline-block; margin-bottom: 5px;">PG DTV</div> <div style="border: 1px solid black; padding: 2px; display: inline-block; margin-bottom: 5px;">SLV</div> <div style="border: 1px solid black; padding: 2px; display: inline-block; margin-bottom: 5px;">PGV</div> <div style="border: 1px solid black; padding: 2px; display: inline-block; margin-bottom: 5px;">PM SLV</div> <div style="border: 1px solid black; padding: 2px; display: inline-block; margin-bottom: 5px;">PM PGV</div> 0000 to FFFF Hex	0	-	-

Parameter No.	Function name	Monitor or Data Range	Default data	Setting during RUN	Unit
X17	Third Last Multiple Alarm 3	<div style="display: flex; justify-content: space-between; font-size: small;"> <span>V/f</span> <span>DTV</span> <span>PG V/f</span> <span>PG DTV</span> </div> <div style="display: flex; justify-content: space-between; font-size: small;"> <span>SLV</span> <span>PGV</span> <span>PM SLV</span> <span>PM PGV</span> </div> 0000 to FFFF Hex	0	-	-
X18	Third Last Alarm Sub Code 1	<div style="display: flex; justify-content: space-between; font-size: small;"> <span>V/f</span> <span>DTV</span> <span>PG V/f</span> <span>PG DTV</span> </div> <div style="display: flex; justify-content: space-between; font-size: small;"> <span>SLV</span> <span>PGV</span> <span>PM SLV</span> <span>PM PGV</span> </div> 0 to 9999	0	-	-
X19	Third Last Multiple Alarm Sub Code 2	<div style="display: flex; justify-content: space-between; font-size: small;"> <span>V/f</span> <span>DTV</span> <span>PG V/f</span> <span>PG DTV</span> </div> <div style="display: flex; justify-content: space-between; font-size: small;"> <span>SLV</span> <span>PGV</span> <span>PM SLV</span> <span>PM PGV</span> </div> 0 to 9999	0	-	-
X20	Latest Alarm Info. Output Frequency	<div style="display: flex; justify-content: space-between; font-size: small;"> <span>V/f</span> <span>DTV</span> <span>PG V/f</span> <span>PG DTV</span> </div> <div style="display: flex; justify-content: space-between; font-size: small;"> <span>SLV</span> <span>PGV</span> <span>PM SLV</span> <span>PM PGV</span> </div> 0.00 to 655.35 Hz	0	-	Hz
X21	Latest Alarm Info. Output Current	<div style="display: flex; justify-content: space-between; font-size: small;"> <span>V/f</span> <span>DTV</span> <span>PG V/f</span> <span>PG DTV</span> </div> <div style="display: flex; justify-content: space-between; font-size: small;"> <span>SLV</span> <span>PGV</span> <span>PM SLV</span> <span>PM PGV</span> </div> 0.00 to 99.99A	0	-	A
X22	Latest Alarm Info. Output Voltage	<div style="display: flex; justify-content: space-between; font-size: small;"> <span>V/f</span> <span>DTV</span> <span>PG V/f</span> <span>PG DTV</span> </div> <div style="display: flex; justify-content: space-between; font-size: small;"> <span>SLV</span> <span>PGV</span> <span>PM SLV</span> <span>PM PGV</span> </div> 0 to 1000 A	0	-	V
X23	Latest Alarm Info. Torque Monitor	<div style="display: flex; justify-content: space-between; font-size: small;"> <span>V/f</span> <span>DTV</span> <span>PG V/f</span> <span>PG DTV</span> </div> <div style="display: flex; justify-content: space-between; font-size: small;"> <span>SLV</span> <span>PGV</span> <span>PM SLV</span> <span>PM PGV</span> </div> -999 to 999	0	-	%
X24	Latest Alarm Info. Frequency Command	<div style="display: flex; justify-content: space-between; font-size: small;"> <span>V/f</span> <span>DTV</span> <span>PG V/f</span> <span>PG DTV</span> </div> <div style="display: flex; justify-content: space-between; font-size: small;"> <span>SLV</span> <span>PGV</span> <span>PM SLV</span> <span>PM PGV</span> </div> 0.00 to 655.35	0	-	Hz



Parameter No.	Function name	Monitor or Data Range	Default data	Setting during RUN	Unit
X25	Latest Alarm Info. Running Status 1	<div style="display: flex; justify-content: space-between; border: 1px solid black; padding: 2px;"> <span>V/f</span> <span>DTV</span> <span>PG V/f</span> <span>PG DTV</span> </div> <div style="display: flex; justify-content: space-between; border: 1px solid black; padding: 2px;"> <span>SLV</span> <span>PGV</span> <span>PM SLV</span> <span>PM PGV</span> </div> <p>Bit15: BUSY (During function code data writing)            Bit14: -            Bit13: -            Bit12: RL (Communications effective)            Bit11: ALM (Alarm relay)            Bit10: DEC (During deceleration)            Bit9: ACC (During acceleration)            Bit8: IL (During current limiting)            Bit7: VL (During voltage limiting)            Bit6: TL (Torque limiting)            Bit5: NUV (Main circuit DC voltage established)            Bit4: BRK (During braking)            Bit3: INT (Inverter shut down)            Bit2: EXT (During DC braking or during pre-exciting)            Bit1: REV (During reverse operation)            Bit0: FWD (During forward operation)</p>	0	-	-
X26	Latest Alarm Info. Cumulative Ope. time	<div style="display: flex; justify-content: space-between; border: 1px solid black; padding: 2px;"> <span>V/f</span> <span>DTV</span> <span>PG V/f</span> <span>PG DTV</span> </div> <div style="display: flex; justify-content: space-between; border: 1px solid black; padding: 2px;"> <span>SLV</span> <span>PGV</span> <span>PM SLV</span> <span>PM PGV</span> </div> <p>0 to 655350 hour</p>	0	-	h
X27	Latest Alarm Info. Number of Startups	<div style="display: flex; justify-content: space-between; border: 1px solid black; padding: 2px;"> <span>V/f</span> <span>DTV</span> <span>PG V/f</span> <span>PG DTV</span> </div> <div style="display: flex; justify-content: space-between; border: 1px solid black; padding: 2px;"> <span>SLV</span> <span>PGV</span> <span>PM SLV</span> <span>PM PGV</span> </div> <p>0 to 65,535</p>	0	-	-
X28	Latest Alarm Info. Main Circuit DC Voltage	<div style="display: flex; justify-content: space-between; border: 1px solid black; padding: 2px;"> <span>V/f</span> <span>DTV</span> <span>PG V/f</span> <span>PG DTV</span> </div> <div style="display: flex; justify-content: space-between; border: 1px solid black; padding: 2px;"> <span>SLV</span> <span>PGV</span> <span>PM SLV</span> <span>PM PGV</span> </div> <p>0.0 to 1,000.0 V</p>	0.0	-	V
X29	Latest Alarm Info. Internal Air Temperature	<div style="display: flex; justify-content: space-between; border: 1px solid black; padding: 2px;"> <span>V/f</span> <span>DTV</span> <span>PG V/f</span> <span>PG DTV</span> </div> <div style="display: flex; justify-content: space-between; border: 1px solid black; padding: 2px;"> <span>SLV</span> <span>PGV</span> <span>PM SLV</span> <span>PM PGV</span> </div> <p>-32768 to 32767</p>	0	-	degC
X30	Latest Alarm Info. Heat Sink Temperature	<div style="display: flex; justify-content: space-between; border: 1px solid black; padding: 2px;"> <span>V/f</span> <span>DTV</span> <span>PG V/f</span> <span>PG DTV</span> </div> <div style="display: flex; justify-content: space-between; border: 1px solid black; padding: 2px;"> <span>SLV</span> <span>PGV</span> <span>PM SLV</span> <span>PM PGV</span> </div> <p>-32,768 to 32,767</p>	0	-	degC

Parameter No.	Function name	Monitor or Data Range	Default data	Setting during RUN	Unit
X31	Latest Alarm Info. Input Terminal	<div style="display: flex; justify-content: space-between; border-bottom: 1px solid black; padding-bottom: 2px;"> <span>V/f</span> <span>DTV</span> <span>PG V/f</span> <span>PG DTV</span> </div> <div style="display: flex; justify-content: space-between; border-bottom: 1px solid black; padding-bottom: 2px;"> <span>SLV</span> <span>PGV</span> <span>PM SLV</span> <span>PM PGV</span> </div> Bit15: --- Bit14: --- Bit13: --- Bit12: EN2 Bit11: EN1 Bit10: --- Bit9: --- Bit8: --- Bit7: --- Bit6: DI5 Bit5: DI4 Bit4: DI3 Bit3: DI2 Bit2: DI1 Bit1: DI7 Bit0: DI6	0	-	-
X32	Latest Alarm Info. Output Terminal	<div style="display: flex; justify-content: space-between; border-bottom: 1px solid black; padding-bottom: 2px;"> <span>V/f</span> <span>DTV</span> <span>PG V/f</span> <span>PG DTV</span> </div> <div style="display: flex; justify-content: space-between; border-bottom: 1px solid black; padding-bottom: 2px;"> <span>SLV</span> <span>PGV</span> <span>PM SLV</span> <span>PM PGV</span> </div> Bit15: --- Bit14: --- Bit13: --- Bit12: --- Bit11: --- Bit10: --- Bit9: --- Bit8: RO Bit7: --- Bit6: --- Bit5: --- Bit4: --- Bit3: --- Bit2: --- Bit1: DO2 Bit0: DO1	0	-	-

Parameter No.	Function name	Monitor or Data Range	Default data	Setting during RUN	Unit
X33	Latest Alarm Info. Input Terminal via Communication	<div style="display: flex; justify-content: space-between; border: 1px solid black; padding: 2px;"> <span>V/f</span> <span>DTV</span> <span>PG V/f</span> <span>PG DTV</span> </div> <div style="display: flex; justify-content: space-between; border: 1px solid black; padding: 2px; margin-top: 2px;"> <span>SLV</span> <span>PGV</span> <span>PM SLV</span> <span>PM PGV</span> </div> <p>Bit15: RST            Bit14: DI7            Bit13: DI6            Bit12: ---            Bit11: ---            Bit10: ---            Bit9: ---            Bit8: ---            Bit7: ---            Bit6: DI5            Bit5: DI4            Bit4: DI3            Bit3: DI2            Bit2: DI1            Bit1: REV            Bit0: FWD</p>	0	-	-
X34	Latest Alarm Info. Output Terminal via Communication	<div style="display: flex; justify-content: space-between; border: 1px solid black; padding: 2px;"> <span>V/f</span> <span>DTV</span> <span>PG V/f</span> <span>PG DTV</span> </div> <div style="display: flex; justify-content: space-between; border: 1px solid black; padding: 2px; margin-top: 2px;"> <span>SLV</span> <span>PGV</span> <span>PM SLV</span> <span>PM PGV</span> </div> <p>Bit15: ---            Bit14: ---            Bit13: ---            Bit12: ---            Bit11: ---            Bit10: ---            Bit9: ---            Bit8: RO            Bit7: ---            Bit6: ---            Bit5: ---            Bit4: ---            Bit3: ---            Bit2: ---            Bit1: DO2            Bit0: DO1</p>	0	-	-
X35	Latest Alarm Info. Input Power	<div style="display: flex; justify-content: space-between; border: 1px solid black; padding: 2px;"> <span>V/f</span> <span>DTV</span> <span>PG V/f</span> <span>PG DTV</span> </div> <div style="display: flex; justify-content: space-between; border: 1px solid black; padding: 2px; margin-top: 2px;"> <span>SLV</span> <span>PGV</span> <span>PM SLV</span> <span>PM PGV</span> </div> <p>0.00 to 9999 kW</p>	0	-	kW

Parameter No.	Function name	Monitor or Data Range	Default data	Setting during RUN	Unit
X36	Latest Alarm Info. Running Status 2	<div style="display: flex; justify-content: space-between; margin-bottom: 5px;"> <span>V/f</span> <span>DTV</span> <span>PG V/f</span> <span>PG DTV</span> </div> <div style="display: flex; justify-content: space-between; margin-bottom: 5px;"> <span>SLV</span> <span>PGV</span> <span>PM SLV</span> <span>PM PGV</span> </div> <p>Bit15: Motor type            1: PM motor            0: Induction motor            Bit14: During EN circuit diagnosis            Bit7: During speed control (1 during control)            Bit5 to 4: Selected motor            00: 1st motor            01: 2nd motor            10: Reserved            11: Reserved            Bit3 to 0: Control method            0000: V/f control without slip compensation            0001: Dynamic torque vector control            0010: V/f control with slip compensation            0011: V/f control with speed sensor            0100: Dynamic torque vector control with speed sensor            0101: Vector control without speed sensor            0110: Vector control with speed sensor            0111: Torque control (Vector control without speed sensor)            1000: Torque control (Vector control with speed sensor)</p>	0	-	-
X37	Latest Alarm Info. Speed Detection	<div style="display: flex; justify-content: space-between; margin-bottom: 5px;"> <span>V/f</span> <span>DTV</span> <span>PG V/f</span> <span>PG DTV</span> </div> <div style="display: flex; justify-content: space-between; margin-bottom: 5px;"> <span>SLV</span> <span>PGV</span> <span>PM SLV</span> <span>PM PGV</span> </div> <p>-32768 to 32767</p>	0	-	-

Parameter No.	Function name	Monitor or Data Range	Default data	Setting during RUN	Unit
X38	Latest Alarm Info. Running Status 3	<div style="display: flex; justify-content: space-between; border: 1px solid black; padding: 2px;"> <span>V/f</span> <span>DTV</span> <span>PG V/f</span> <span>PG DTV</span> </div> <div style="display: flex; justify-content: space-between; border: 1px solid black; padding: 2px;"> <span>SLV</span> <span>PGV</span> <span>PM SLV</span> <span>PM PGV</span> </div> <p>Bit15: ---            Bit14: OL (Overload warning)            Bit13: LOC (Light load detection)            Bit12: OL2 (Overload warning 2)            Bit11: OLP (During active drive)            Bit11: OLP (During active drive)            Bit10: LIFE (Life warning)            Bit9: OHF (Fin Overheat warning)            Bit8: TRY (During retry)            Bit7: FAN (Fan operation signal)            Bit6: REF (RUN command source)            Bit5: THM (Thermal warning)            Bit4: IPF (During restart after instantaneous power failure)            Bit3: SETM (2nd motor selection)            Bit2: IRDY (Operation ready)            Bit1: FDT1 (Over set Frequency arrival)            Bit0: FAR1 (Constant speed arrival)</p>	0	-	-
X49	Fault Counter	<div style="display: flex; justify-content: space-between; border: 1px solid black; padding: 2px;"> <span>V/f</span> <span>DTV</span> <span>PG V/f</span> <span>PG DTV</span> </div> <div style="display: flex; justify-content: space-between; border: 1px solid black; padding: 2px;"> <span>SLV</span> <span>PGV</span> <span>PM SLV</span> <span>PM PGV</span> </div> <p>0 to 65535</p>	0	-	-
X60	Last Info. Alarm Info. Output Frequency	<div style="display: flex; justify-content: space-between; border: 1px solid black; padding: 2px;"> <span>V/f</span> <span>DTV</span> <span>PG V/f</span> <span>PG DTV</span> </div> <div style="display: flex; justify-content: space-between; border: 1px solid black; padding: 2px;"> <span>SLV</span> <span>PGV</span> <span>PM SLV</span> <span>PM PGV</span> </div> <p>0.00 to 655.35 Hz</p>	0	-	Hz
X61	Last Alarm Info. Output Current	<div style="display: flex; justify-content: space-between; border: 1px solid black; padding: 2px;"> <span>V/f</span> <span>DTV</span> <span>PG V/f</span> <span>PG DTV</span> </div> <div style="display: flex; justify-content: space-between; border: 1px solid black; padding: 2px;"> <span>SLV</span> <span>PGV</span> <span>PM SLV</span> <span>PM PGV</span> </div> <p>0.00 to 99.99A</p>	0	-	A
X62	Last Alarm Info. Output Voltage	<div style="display: flex; justify-content: space-between; border: 1px solid black; padding: 2px;"> <span>V/f</span> <span>DTV</span> <span>PG V/f</span> <span>PG DTV</span> </div> <div style="display: flex; justify-content: space-between; border: 1px solid black; padding: 2px;"> <span>SLV</span> <span>PGV</span> <span>PM SLV</span> <span>PM PGV</span> </div> <p>0 to 1000 V</p>	0	-	V
X63	Last Alarm Info. Torque Monitor	<div style="display: flex; justify-content: space-between; border: 1px solid black; padding: 2px;"> <span>V/f</span> <span>DTV</span> <span>PG V/f</span> <span>PG DTV</span> </div> <div style="display: flex; justify-content: space-between; border: 1px solid black; padding: 2px;"> <span>SLV</span> <span>PGV</span> <span>PM SLV</span> <span>PM PGV</span> </div> <p>-999 to 999</p>	0	-	%

Parameter No.	Function name	Monitor or Data Range	Default data	Setting during RUN	Unit
X64	Last Alarm Info. Frequency Command	<div style="display: flex; justify-content: space-between; border-bottom: 1px solid black; padding-bottom: 2px;"> <span>V/f</span> <span>DTV</span> <span>PG V/f</span> <span>PG DTV</span> </div> <div style="display: flex; justify-content: space-between; border-bottom: 1px solid black; padding-bottom: 2px;"> <span>SLV</span> <span>PGV</span> <span>PM SLV</span> <span>PM PGV</span> </div> 0.00 to 655.35	0	-	Hz
X65	Last Alarm Info. Running Status	<div style="display: flex; justify-content: space-between; border-bottom: 1px solid black; padding-bottom: 2px;"> <span>V/f</span> <span>DTV</span> <span>PG V/f</span> <span>PG DTV</span> </div> <div style="display: flex; justify-content: space-between; border-bottom: 1px solid black; padding-bottom: 2px;"> <span>SLV</span> <span>PGV</span> <span>PM SLV</span> <span>PM PGV</span> </div> Bit15: BUSY (During function code data writing) Bit14: - Bit13: - Bit12: RL (Communications effective) Bit11: ALM (Alarm relay) Bit10: DEC (During deceleration) Bit9: ACC (During acceleration) Bit8: IL (During current limiting) Bit7: VL (During voltage limiting) Bit6: TL (Torque limiting) Bit5: NUV (Main circuit DC voltage established) Bit4: BRK (During braking) Bit3: INT (Inverter shut down) Bit2: EXT (During DC braking or during pre-exciting) Bit1: REV (During reverse operation) Bit0: FWD (During forward operation)	0	-	-
X66	Last Alarm Info. Cumulative Ope. Time	<div style="display: flex; justify-content: space-between; border-bottom: 1px solid black; padding-bottom: 2px;"> <span>V/f</span> <span>DTV</span> <span>PG V/f</span> <span>PG DTV</span> </div> <div style="display: flex; justify-content: space-between; border-bottom: 1px solid black; padding-bottom: 2px;"> <span>SLV</span> <span>PGV</span> <span>PM SLV</span> <span>PM PGV</span> </div> 0 to 655350 hour	0	-	h
X67	Last Alarm Info. Number of Start-ups	<div style="display: flex; justify-content: space-between; border-bottom: 1px solid black; padding-bottom: 2px;"> <span>V/f</span> <span>DTV</span> <span>PG V/f</span> <span>PG DTV</span> </div> <div style="display: flex; justify-content: space-between; border-bottom: 1px solid black; padding-bottom: 2px;"> <span>SLV</span> <span>PGV</span> <span>PM SLV</span> <span>PM PGV</span> </div> 0 to 65,535	0	-	-
X68	Last Alarm Info. Main Circuit DC Voltage	<div style="display: flex; justify-content: space-between; border-bottom: 1px solid black; padding-bottom: 2px;"> <span>V/f</span> <span>DTV</span> <span>PG V/f</span> <span>PG DTV</span> </div> <div style="display: flex; justify-content: space-between; border-bottom: 1px solid black; padding-bottom: 2px;"> <span>SLV</span> <span>PGV</span> <span>PM SLV</span> <span>PM PGV</span> </div> 0.0 to 1,000.0 V	0.0	-	V
X69	Last Alarm Info Internal Air Temperature	<div style="display: flex; justify-content: space-between; border-bottom: 1px solid black; padding-bottom: 2px;"> <span>V/f</span> <span>DTV</span> <span>PG V/f</span> <span>PG DTV</span> </div> <div style="display: flex; justify-content: space-between; border-bottom: 1px solid black; padding-bottom: 2px;"> <span>SLV</span> <span>PGV</span> <span>PM SLV</span> <span>PM PGV</span> </div> -32768 to 32767	0	-	degC

Parameter No.	Function name	Monitor or Data Range	Default data	Setting during RUN	Unit
X70	Last Alarm Info. Heat Sink Temperature	<div style="display: flex; justify-content: space-between; border: 1px solid black; padding: 2px;"> <span>V/f</span> <span>DTV</span> <span>PG V/f</span> <span>PG DTV</span> </div> <div style="display: flex; justify-content: space-between; border: 1px solid black; padding: 2px;"> <span>SLV</span> <span>PGV</span> <span>PM SLV</span> <span>PM PGV</span> </div> <p>-32,768 to 32,767</p>	0	-	degC
X71	Last Alarm Info. Input Terminal	<div style="display: flex; justify-content: space-between; border: 1px solid black; padding: 2px;"> <span>V/f</span> <span>DTV</span> <span>PG V/f</span> <span>PG DTV</span> </div> <div style="display: flex; justify-content: space-between; border: 1px solid black; padding: 2px;"> <span>SLV</span> <span>PGV</span> <span>PM SLV</span> <span>PM PGV</span> </div> <p>Bit15: ---            Bit14: ---            Bit13: ---            Bit12: EN2            Bit11: EN1            Bit10: ---            Bit9: ---            Bit8: ---            Bit7: ---            Bit6: DI5            Bit5: DI4            Bit4: DI3            Bit3: DI2            Bit2: DI1            Bit1: DI7            Bit0: DI6</p>	0	-	-
X72	Last Alarm Info. Output Terminal	<div style="display: flex; justify-content: space-between; border: 1px solid black; padding: 2px;"> <span>V/f</span> <span>DTV</span> <span>PG V/f</span> <span>PG DTV</span> </div> <div style="display: flex; justify-content: space-between; border: 1px solid black; padding: 2px;"> <span>SLV</span> <span>PGV</span> <span>PM SLV</span> <span>PM PGV</span> </div> <p>Bit15: ---            Bit14: ---            Bit13: ---            Bit12: ---            Bit11: ---            Bit10: ---            Bit9: ---            Bit8: RO            Bit7: ---            Bit6: ---            Bit5: ---            Bit4: ---            Bit3: ---            Bit2: ---            Bit1: DO2            Bit0: DO1</p>	0	-	-

Parameter No.	Function name	Monitor or Data Range	Default data	Setting during RUN	Unit
X73	Last Alarm Info. Input Terminal via Communication	<div style="display: flex; justify-content: space-between; border-bottom: 1px solid black; padding-bottom: 2px;"> <span>V/f</span> <span>DTV</span> <span>PG V/f</span> <span>PG DTV</span> </div> <div style="display: flex; justify-content: space-between; border-bottom: 1px solid black; padding-bottom: 2px;"> <span>SLV</span> <span>PGV</span> <span>PM SLV</span> <span>PM PGV</span> </div> Bit15: RST Bit14: DI7 Bit13: DI6 Bit12: --- Bit11: --- Bit10: --- Bit9: --- Bit8: --- Bit7: --- Bit6: DI5 Bit5: DI4 Bit4: DI3 Bit3: DI2 Bit2: DI1 Bit1: REV Bit0: FWD	0	-	-
X74	Last Alarm Info. Output Terminal via Communication	<div style="display: flex; justify-content: space-between; border-bottom: 1px solid black; padding-bottom: 2px;"> <span>V/f</span> <span>DTV</span> <span>PG V/f</span> <span>PG DTV</span> </div> <div style="display: flex; justify-content: space-between; border-bottom: 1px solid black; padding-bottom: 2px;"> <span>SLV</span> <span>PGV</span> <span>PM SLV</span> <span>PM PGV</span> </div> Bit15: --- Bit14: --- Bit13: --- Bit12: --- Bit11: --- Bit10: --- Bit9: --- Bit8: RO Bit7: --- Bit6: --- Bit5: --- Bit4: --- Bit3: --- Bit2: --- Bit1: DO2 Bit0: DO1	0	-	-



Parameter No.	Function name	Monitor or Data Range	Default data	Setting during RUN	Unit
X76	Last Alarm Info. Running Status 2	<div style="display: flex; justify-content: space-between; border-bottom: 1px solid black; padding-bottom: 2px;"> <span>V/f</span> <span>DTV</span> <span>PG V/f</span> <span>PG DTV</span> </div> <div style="display: flex; justify-content: space-between; border-bottom: 1px solid black; padding-bottom: 2px;"> <span>SLV</span> <span>PGV</span> <span>PM SLV</span> <span>PM PGV</span> </div> <p>Bit15: Motor type  1: PM motor  0: Induction motor  Bit14: During EN circuit diagnosis  Bit7: During speed control (1 during control)  Bit5 to 4: Selected motor  00: 1st motor  01: 2nd motor  10: Reserved  11: Reserved  Bit3 to 0: Control method  0000: V/f control without slip compensation  0001: Dynamic torque vector control  0010: V/f control with slip compensation  0011: V/f control with speed sensor  0100: Dynamic torque vector control with speed sensor  0101: Vector control without speed sensor  0110: Vector control with speed sensor  0111: Torque control (Vector control without speed sensor)  1000: Torque control (Vector control with speed sensor)</p>	0	-	-
X77	Last Alarm Info. Speed Detection	<div style="display: flex; justify-content: space-between; border-bottom: 1px solid black; padding-bottom: 2px;"> <span>V/f</span> <span>DTV</span> <span>PG V/f</span> <span>PG DTV</span> </div> <div style="display: flex; justify-content: space-between; border-bottom: 1px solid black; padding-bottom: 2px;"> <span>SLV</span> <span>PGV</span> <span>PM SLV</span> <span>PM PGV</span> </div> <p>-32768 to 32767</p>	0	-	-

Parameter No.	Function name	Monitor or Data Range	Default data	Setting during RUN	Unit
X78	Last Alarm Info. Running Status 3	<div style="display: flex; justify-content: space-between; border-bottom: 1px solid black; padding-bottom: 2px;"> <span>V/f</span> <span>DTV</span> <span>PG V/f</span> <span>PG DTV</span> </div> <div style="display: flex; justify-content: space-between; border-bottom: 1px solid black; padding-bottom: 2px;"> <span>SLV</span> <span>PGV</span> <span>PM SLV</span> <span>PM PGV</span> </div> <p>Bit15: ---                      Bit14: OL (Overload warning)                      Bit13: LOC (Light load detection)                      Bit12: OL2 (Overload warning 2)                      Bit11: OLP (During active drive)                      Bit11: OLP (During active drive)                      Bit10: LIFE (Life warning)                      Bit9: OHF (Fin Overheat warning)                      Bit8: TRY (During retry)                      Bit7: FAN (Fan operation signal)                      Bit6: REF (RUN command source)                      Bit5: THM (Thermal warning)                      Bit4: IPF (During restart after instantaneous power failure)                      Bit3: SETM (2nd motor selection)                      Bit2: IRDY (Operation ready)                      Bit1: FDT1 (Over set Frequency arrival)                      Bit0: FAR1 (Constant speed arrival)</p>	0	-	-
X97	Input Input Terminal [PTC] Input Voltage	<div style="display: flex; justify-content: space-between; border-bottom: 1px solid black; padding-bottom: 2px;"> <span>V/f</span> <span>DTV</span> <span>PG V/f</span> <span>PG DTV</span> </div> <div style="display: flex; justify-content: space-between; border-bottom: 1px solid black; padding-bottom: 2px;"> <span>SLV</span> <span>PGV</span> <span>PM SLV</span> <span>PM PGV</span> </div> <p>-0.0 to 12.0</p>	0	-	V
X108	Latest Alarm Info. Cumulative Running Time	<div style="display: flex; justify-content: space-between; border-bottom: 1px solid black; padding-bottom: 2px;"> <span>V/f</span> <span>DTV</span> <span>PG V/f</span> <span>PG DTV</span> </div> <div style="display: flex; justify-content: space-between; border-bottom: 1px solid black; padding-bottom: 2px;"> <span>SLV</span> <span>PGV</span> <span>PM SLV</span> <span>PM PGV</span> </div> <p>0 to 655350 hour</p>	0	-	h
X118	Last Alarm Info. Cumulative Running Time	<div style="display: flex; justify-content: space-between; border-bottom: 1px solid black; padding-bottom: 2px;"> <span>V/f</span> <span>DTV</span> <span>PG V/f</span> <span>PG DTV</span> </div> <div style="display: flex; justify-content: space-between; border-bottom: 1px solid black; padding-bottom: 2px;"> <span>SLV</span> <span>PGV</span> <span>PM SLV</span> <span>PM PGV</span> </div> <p>0 to 655350 hour</p>	0	-	h
X128	Second last Alarm Info. Cumulative Running Time	<div style="display: flex; justify-content: space-between; border-bottom: 1px solid black; padding-bottom: 2px;"> <span>V/f</span> <span>DTV</span> <span>PG V/f</span> <span>PG DTV</span> </div> <div style="display: flex; justify-content: space-between; border-bottom: 1px solid black; padding-bottom: 2px;"> <span>SLV</span> <span>PGV</span> <span>PM SLV</span> <span>PM PGV</span> </div> <p>0 to 655350 hour</p>	0	-	h
X138	Third last Alarm Info. Cumulative Running Time	<div style="display: flex; justify-content: space-between; border-bottom: 1px solid black; padding-bottom: 2px;"> <span>V/f</span> <span>DTV</span> <span>PG V/f</span> <span>PG DTV</span> </div> <div style="display: flex; justify-content: space-between; border-bottom: 1px solid black; padding-bottom: 2px;"> <span>SLV</span> <span>PGV</span> <span>PM SLV</span> <span>PM PGV</span> </div> <p>0 to 655350 hour</p>	0	-	h

Parameter No.	Function name	Monitor or Data Range	Default data	Setting during RUN	Unit
X140	4th last Alarm History/Number of Consecutive Same Alarms	<div style="display: flex; justify-content: space-between; border: 1px solid black; padding: 2px;"> <span>V/f</span> <span>DTV</span> <span>PG V/f</span> <span>PG DTV</span> </div> <div style="display: flex; justify-content: space-between; border: 1px solid black; padding: 2px; margin-top: 5px;"> <span>SLV</span> <span>PGV</span> <span>PM SLV</span> <span>PM PGV</span> </div> <p>0000 to FFFF hex (MSB: 00 to FF hex, LSB:00 to FE hex) MSB: Number of alarm</p> <p>LSB: 00 to FE hex 00 hex (0) : No alarm 01 hex (1) : OC1 Overcurrent protection (during acceleration) 02 hex (2) : OC2 Overcurrent protection (during deceleration) 03 hex (3) : OC3 Overcurrent protection (during constant speed operation) 06 hex (4) : OU1 Overvoltage protection (during acceleration) 07 hex (7) : OU2 Overvoltage protection (during deceleration) 08 hex (8) : OU3 Overvoltage protection (during constant speed operation or stopping) 0A hex (10) : LU Undervoltage protection 0B hex (11) : Lin Input phase loss protection 10 hex (16) : PbF Inrush current avoidance circuit error 11 hex (17) : OH1 Heat sink overheat 12 hex (18) : OH2 External alarm input 13 hex (19) : OH3 Inverter internal overheat 14 hex (20) : OH4 Motor protection (PTC thermistor) 16 hex (22) : dBH Braking resistor overheat 17 hex (23) : OL1 Motor 1 overload</p>	0	-	-

Parameter No.	Function name	Monitor or Data Range	Default data	Setting during RUN	Unit
X140	4th last Alarm History/Number of Consecutive Same Alarms	18 hex (24) : OL2 Motor 2 overload 19 hex (25) : OLU Inverter overload 1B hex (27) : OS Over speed protection 1C hex (28) : Pg PG disconnection 1F hex (31) : Er1 Memory error 20 hex (32) : Er2 Operator communications 23 hex (35) : Er5 Option card error 24 hex (36) : Er6 Operation protection 25 hex (37) : Er7 Tuning error 2A hex (42) : Erd Detection of step-out 2E hex (46) : OPL Output phase loss protection 2F hex (47) : ErE Following error (excessive speed deviation) 32 hex (50) : ErC Magnetic pole position detection error 33 hex (51) : ErF Data save error in case of undervoltage 34 hex (52) : d0 Excessive positioning deviation 35 hex (53) : ErP (RS-485 communications error, Option card) 38 hex (56) : Ero Position control error 39 hex (57) : ECF EN circuit failure 3A hex (58) : CoF PID feedback disconnection detected 3B hex (59) : dbA Braking resistor overheat 44 hex (68) : ErU Support tool communication disconnection 46 hex (70) : OH6 Inrush current prevention resistor overheat FD hex (253) : Lok Locked by password FE hex (254) : Err Mock alarm (Subcode = 9998)	0	-	-

Parameter No.	Function name	Monitor or Data Range	Default data	Setting during RUN	Unit
X141	Fourth last Alarm Info. Output Frequency	<div style="display: flex; justify-content: space-between; border: 1px solid black; padding: 2px;"> <span>V/f</span> <span>DTV</span> <span>PG V/f</span> <span>PG DTV</span> </div> <div style="display: flex; justify-content: space-between; border: 1px solid black; padding: 2px;"> <span>SLV</span> <span>PGV</span> <span>PM SLV</span> <span>PM PGV</span> </div> 0.00 to 655.35 Hz	0	-	Hz
X142	Fourth last Alarm Info. Output Current	<div style="display: flex; justify-content: space-between; border: 1px solid black; padding: 2px;"> <span>V/f</span> <span>DTV</span> <span>PG V/f</span> <span>PG DTV</span> </div> <div style="display: flex; justify-content: space-between; border: 1px solid black; padding: 2px;"> <span>SLV</span> <span>PGV</span> <span>PM SLV</span> <span>PM PGV</span> </div> 0.00 to 99.99 A	0	-	A
X143	Fourth Last Alarm Info. Cumulative Ope. time	<div style="display: flex; justify-content: space-between; border: 1px solid black; padding: 2px;"> <span>V/f</span> <span>DTV</span> <span>PG V/f</span> <span>PG DTV</span> </div> <div style="display: flex; justify-content: space-between; border: 1px solid black; padding: 2px;"> <span>SLV</span> <span>PGV</span> <span>PM SLV</span> <span>PM PGV</span> </div> 0 to 655350 hour	0	-	h
X144	Fourth Last Alarm Info. Main Circuit DC Voltage	<div style="display: flex; justify-content: space-between; border: 1px solid black; padding: 2px;"> <span>V/f</span> <span>DTV</span> <span>PG V/f</span> <span>PG DTV</span> </div> <div style="display: flex; justify-content: space-between; border: 1px solid black; padding: 2px;"> <span>SLV</span> <span>PGV</span> <span>PM SLV</span> <span>PM PGV</span> </div> 0.0 to 1,000.0 V	0.0	-	V
X148	Fourth Last Alarm Info. Cumulative Running Time	<div style="display: flex; justify-content: space-between; border: 1px solid black; padding: 2px;"> <span>V/f</span> <span>DTV</span> <span>PG V/f</span> <span>PG DTV</span> </div> <div style="display: flex; justify-content: space-between; border: 1px solid black; padding: 2px;"> <span>SLV</span> <span>PGV</span> <span>PM SLV</span> <span>PM PGV</span> </div> 0 to 655350 hour	0	-	h
X149	Fourth Last Alarm Info. Running Status	<div style="display: flex; justify-content: space-between; border: 1px solid black; padding: 2px;"> <span>V/f</span> <span>DTV</span> <span>PG V/f</span> <span>PG DTV</span> </div> <div style="display: flex; justify-content: space-between; border: 1px solid black; padding: 2px;"> <span>SLV</span> <span>PGV</span> <span>PM SLV</span> <span>PM PGV</span> </div> Bit15: BUSY (During function code data writing) Bit14: - Bit13: - Bit12: RL (Communications effective) Bit11: ALM (Alarm relay) Bit10: DEC (During deceleration) Bit9: ACC (During acceleration) Bit8: IL (During current limiting) Bit7: VL (During voltage limiting) Bit6: TL (Torque limiting) Bit5: NUV (Main circuit DC voltage established) Bit4: BRK (During braking) Bit3: INT (Inverter shut down) Bit2: EXT (During DC braking or during pre-exciting) Bit1: REV (During reverse operation) Bit0: FWD (During forward operation)	0	-	-

Parameter No.	Function name	Monitor or Data Range	Default data	Setting during RUN	Unit
X150	5th last Alarm History/Number of Consecutive Same Alarms	<div style="display: flex; justify-content: space-between; border: 1px solid black; padding: 2px;"> <span>V/f</span> <span>DTV</span> <span>PG V/f</span> <span>PG DTV</span> </div> <div style="display: flex; justify-content: space-between; border: 1px solid black; padding: 2px; margin-top: 5px;"> <span>SLV</span> <span>PGV</span> <span>PM SLV</span> <span>PM PGV</span> </div> <p>0000 to FFFF hex (MSB: 00 to FF hex, LSB:00 to FE hex) MSB: Number of alarm</p> <p>LSB: 00 to FE hex 00 hex (0) : No alarm 01 hex (1) : OC1 Overcurrent protection (during acceleration) 02 hex (2) : OC2 Overcurrent protection (during deceleration) 03 hex (3) : OC3 Overcurrent protection (during constant speed operation) 06 hex (4) : OU1 Overvoltage protection (during acceleration) 07 hex (7) : OU2 Overvoltage protection (during deceleration) 08 hex (8) : OU3 Overvoltage protection (during constant speed operation or stopping) 0A hex (10) : LU Undervoltage protection 0B hex (11) : Lin Input phase loss protection 10 hex (16) : PbF Inrush current avoidance circuit error 11 hex (17) : OH1 Heat sink overheat 12 hex (18) : OH2 External alarm input 13 hex (19) : OH3 Inverter internal overheat 14 hex (20) : OH4 Motor protection (PTC thermistor) 16 hex (22) : dbH Braking resistor overheat 17 hex (23) : OL1 Motor 1 overload 18 hex (24) : OL2 Motor 2 overload</p>	0	-	-

Parameter No.	Function name	Monitor or Data Range	Default data	Setting during RUN	Unit
X150	5th last Alarm History/Number of Consecutive Same Alarms	19 hex (25) : OLU Inverter overload 1B hex (27) : OS Over speed protection 1C hex (28) : Pg PG disconnection 1F hex (31) : Er1 Memory error 20 hex (32) : Er2 Operator communications 23 hex (35) : Er5 Option card error 24 hex (36) : Er6 Operation protection 25 hex (37) : Er7 Tuning error 2A hex (42) : Erd Detection of step-out 2E hex (46) : OPL Output phase loss protection 2F hex (47) : ErE Following error (excessive speed deviation) 32 hex (50) : ErC Magnetic pole position detection error 33 hex (51) : ErF Data save error in case of undervoltage 34 hex (52) : d0 Excessive positioning deviation 35 hex (53) : ErP (RS-485 communications error, Option card) 38 hex (56) : Ero Position control error 39 hex (57) : ECF EN circuit failure 3A hex (58) : CoF PID feedback disconnection detected 3B hex (59) : dbA Braking resistor overheat 44 hex (68) : ErU Support tool communication disconnection 46 hex (70) : OH6 Inrush current prevention resistor overheat FD hex (253) : Lok Locked by password FE hex (254) : Err Mock alarm (Subcode = 9998)	0	-	-
X151	Fifth Last Alarm Info. Output Frequency	<div style="display: flex; justify-content: space-between; border: 1px solid black; padding: 2px;"> <span>V/f</span> <span>DTV</span> <span>PG V/f</span> <span>PG DTV</span> </div> <div style="display: flex; justify-content: space-between; border: 1px solid black; padding: 2px;"> <span>SLV</span> <span>PGV</span> <span>PM SLV</span> <span>PM PGV</span> </div> 0.00 to 655.35 Hz	0	-	Hz

Parameter No.	Function name	Monitor or Data Range	Default data	Setting during RUN	Unit
X152	Fifth Last Alarm Info. Output Current	<div style="display: flex; justify-content: space-between; border-bottom: 1px solid black; padding-bottom: 2px;"> <span>V/f</span> <span>DTV</span> <span>PG V/f</span> <span>PG DTV</span> </div> <div style="display: flex; justify-content: space-between; border-bottom: 1px solid black; padding-bottom: 2px;"> <span>SLV</span> <span>PGV</span> <span>PM SLV</span> <span>PM PGV</span> </div> 0.00 to 99.99 A	0	-	A
X153	Fifth Last Alarm Info. Cumulative Ope. Time	<div style="display: flex; justify-content: space-between; border-bottom: 1px solid black; padding-bottom: 2px;"> <span>V/f</span> <span>DTV</span> <span>PG V/f</span> <span>PG DTV</span> </div> <div style="display: flex; justify-content: space-between; border-bottom: 1px solid black; padding-bottom: 2px;"> <span>SLV</span> <span>PGV</span> <span>PM SLV</span> <span>PM PGV</span> </div> 0 to 655350 hour	0	-	h
X154	Fifth last Alarm Info. Main Circuit DC Voltage	<div style="display: flex; justify-content: space-between; border-bottom: 1px solid black; padding-bottom: 2px;"> <span>V/f</span> <span>DTV</span> <span>PG V/f</span> <span>PG DTV</span> </div> <div style="display: flex; justify-content: space-between; border-bottom: 1px solid black; padding-bottom: 2px;"> <span>SLV</span> <span>PGV</span> <span>PM SLV</span> <span>PM PGV</span> </div> 0.0 to 1,000.0 V	0.0	-	V
X158	Fifth last Alarm Info. Cumulative Running time	<div style="display: flex; justify-content: space-between; border-bottom: 1px solid black; padding-bottom: 2px;"> <span>V/f</span> <span>DTV</span> <span>PG V/f</span> <span>PG DTV</span> </div> <div style="display: flex; justify-content: space-between; border-bottom: 1px solid black; padding-bottom: 2px;"> <span>SLV</span> <span>PGV</span> <span>PM SLV</span> <span>PM PGV</span> </div> 0 to 655350 hour	0	-	h
X159	Fifth Last Alarm Info. Running Status	<div style="display: flex; justify-content: space-between; border-bottom: 1px solid black; padding-bottom: 2px;"> <span>V/f</span> <span>DTV</span> <span>PG V/f</span> <span>PG DTV</span> </div> <div style="display: flex; justify-content: space-between; border-bottom: 1px solid black; padding-bottom: 2px;"> <span>SLV</span> <span>PGV</span> <span>PM SLV</span> <span>PM PGV</span> </div> Bit15: BUSY (During function code data writing) Bit14: - Bit13: - Bit12: RL (Communications effective) Bit11: ALM (Alarm relay) Bit10: DEC (During deceleration) Bit9: ACC (During acceleration) Bit8: IL (During current limiting) Bit7: VL (During voltage limiting) Bit6: TL (Torque limiting) Bit5: NUV (Main circuit DC voltage established) Bit4: BRK (During braking) Bit3: INT (Inverter shut down) Bit2: EXT (During DC braking or during pre-exciting) Bit1: REV (During reverse operation) Bit0: FWD (During forward operation)	0	-	-



Parameter No.	Function name	Monitor or Data Range	Default data	Setting during RUN	Unit
X00	Latest Alarm History/Number of Consecutive Same Alarms	<div style="display: flex; justify-content: space-between; border: 1px solid black; padding: 2px;"> <span>V/f</span> <span>DTV</span> <span>PG V/f</span> <span>PG DTV</span> </div> <div style="display: flex; justify-content: space-between; border: 1px solid black; padding: 2px; margin-top: 5px;"> <span>SLV</span> <span>PGV</span> <span>PM SLV</span> <span>PM PGV</span> </div> <p>0000 to FFFF hex (MSB: 00 to FF hex, LSB:00 to FE hex) MSB: Number of alarm ("00 hex")</p> <p>LSB: 00 to FE hex 00 hex (0) : No alarm 01 hex (1) : OC1 Overcurrent protection (during acceleration) 02 hex (2) : OC2 Overcurrent protection (during deceleration) 03 hex (3) : OC3 Overcurrent protection (during constant speed operation) 06 hex (4) : OU1 Overvoltage protection (during acceleration) 07 hex (7) : OU2 Overvoltage protection (during deceleration) 08 hex (8) : OU3 Overvoltage protection (during constant speed operation or stopping) 0A hex (10) : LU Undervoltage protection 0B hex (11) : Lin Input phase loss protection 10 hex (16) : PbF Inrush current avoidance circuit error 11 hex (17) : OH1 Heat sink overheat 12 hex (18) : OH2 External alarm input 13 hex (19) : OH3 Inverter internal overheat 14 hex (20) : OH4 Motor protection (PTC thermistor) 16 hex (22) : dBH Braking resistor overheat 17 hex (23) : OL1 Motor 1 overload 18 hex (24) : OL2 Motor 2 overload</p>	0	-	-

Parameter No.	Function name	Monitor or Data Range	Default data	Setting during RUN	Unit
X00	Latest Alarm History/Number of Consecutive Same Alarms	19 hex (25) : OLU Inverter overload 1B hex (27) : OS Over speed protection 1C hex (28) : Pg PG disconnection 1F hex (31) : Er1 Memory error 20 hex (32) : Er2 Operator communications 23 hex (35) : Er5 Option card error 24 hex (36) : Er6 Operation protection 25 hex (37) : Er7 Tuning error 2A hex (42) : Erd Detection of step-out 2E hex (46) : OPL Output phase loss protection 2F hex (47) : ErE Following error (excessive speed deviation) 32 hex (50) : ErC Magnetic pole position detection error 33 hex (51) : ErF Data save error in case of undervoltage 34 hex (52) : d0 Excessive positioning deviation 35 hex (53) : ErP (RS-485 communications error, Option card) 38 hex (56) : Ero Position control error 39 hex (57) : ECF EN circuit failure 3A hex (58) : CoF PID feedback disconnection detected 3B hex (59) : dbA Braking resistor overheat 44 hex (68) : ErU Support tool communication disconnection 46 hex (70) : OH6 Inrush current prevention resistor overheat FD hex (253) : Lok Locked by password FE hex (254) : Err Mock alarm (Subcode = 9998)	0	-	-

## 4-2 List of Parameters by Group

The parameters that are displayed are limited by the setting of Operator (Menu display mode) (E52). To display all parameters, set Operator (Menu display mode) to “2: Full menu mode.” (The default setting for Operator (Menu display mode) (E52) is “2: Full menu mode”.)

Enabled and disabled states for each control mode within the data range of the parameters are indicated by the icon.

Symbol	Control method (F42/A14)
<input type="checkbox"/> V/f	0: IM V/f control
<input type="checkbox"/> DTV	1: IM Dynamic torque vector control
<input type="checkbox"/> PG V/f	3: IM V/f control with speed sensor
<input type="checkbox"/> PG DTV	4: IM Dynamic torque vector control with speed sensor
<input type="checkbox"/> SLV	5: IM Vector control without speed sensor
<input type="checkbox"/> PGV	6: IM Vector control with speed sensor
<input type="checkbox"/> PM SLV	15: PM Vector control without speed and pole position sensor
<input type="checkbox"/> PM PGV	16: PM Vector control with speed and pole position sensor

V/f : Enabled  V/f : Disabled

### 4-2-1 Parameter F (Basic Functions)

Parameter No.	Function name	Monitor or Data Range	Default data	Setting during RUN	Unit	Page
F00	Operator Protection Function Selection	<input type="checkbox"/> V/f <input type="checkbox"/> DTV <input type="checkbox"/> PG V/f <input type="checkbox"/> PG DTV <input type="checkbox"/> SLV <input type="checkbox"/> PGV <input type="checkbox"/> PM SLV <input type="checkbox"/> PM PGV 0: Disable parameter protection, enable Up/Down keys 1: Enable parameter protection, enable Up/Down keys 2: Disable parameter protection, disable Up/Down keys 3: Enable parameter protection, disable Up/Down keys	0	Available	-	page 7-74

Parameter No.	Function name	Monitor or Data Range	Default data	Setting during RUN	Unit	Page
F01	1st Frequency Reference Selection	<div style="display: flex; justify-content: space-between; border-bottom: 1px solid black; padding-bottom: 2px;"> <span>V/f</span> <span>DTV</span> <span>PG V/f</span> <span>PG DTV</span> </div> <div style="display: flex; justify-content: space-between; border-bottom: 1px solid black; padding-bottom: 2px;"> <span>SLV</span> <span>PGV</span> <span>PM SLV</span> <span>PM PGV</span> </div> <p>0 to 15  0: Operator (UP and DOWN keys)  1: Analog voltage input (terminal AI1)  2: Analog current input (terminal AI2 (All))  3: Analog voltage input (terminal AI1) + analog current input (terminal AI2 (All))  5: Analog voltage input (terminal AI2 (AIV))  7: UP/DOWN control  8: Digital Operator (UP and DOWN keys)(balanceless-bumpless switching available)  10: Pattern operation  12: Pulse train input  13: Calculation result  14: RS-485 communication  15: Fieldbus (Reserved)</p>	0	-	-	page 5-27
F02	1st RUN Command Selection	<div style="display: flex; justify-content: space-between; border-bottom: 1px solid black; padding-bottom: 2px;"> <span>V/f</span> <span>DTV</span> <span>PG V/f</span> <span>PG DTV</span> </div> <div style="display: flex; justify-content: space-between; border-bottom: 1px solid black; padding-bottom: 2px;"> <span>SLV</span> <span>PGV</span> <span>PM SLV</span> <span>PM PGV</span> </div> <p>0: Operator (Direction of rotation input: terminal block)  1: External signal (Digital input)  2: Operator (Forward rotation)  3: Operator (Reverse rotation)  4: RS-485 communication  5: Fieldbus (Reserved)</p>	2	-	-	page 5-25
F03	1st Maximum Output Frequency	<div style="display: flex; justify-content: space-between; border-bottom: 1px solid black; padding-bottom: 2px;"> <span>V/f</span> <span>DTV</span> <span>PG V/f</span> <span>PG DTV</span> </div> <div style="display: flex; justify-content: space-between; border-bottom: 1px solid black; padding-bottom: 2px;"> <span>SLV</span> <span>PGV</span> <span>PM SLV</span> <span>PM PGV</span> </div> <p>5.0 to 590.0 Hz</p>	60.0	-	Hz	page 5-19
F04	1st Base Frequency	<div style="display: flex; justify-content: space-between; border-bottom: 1px solid black; padding-bottom: 2px;"> <span>V/f</span> <span>DTV</span> <span>PG V/f</span> <span>PG DTV</span> </div> <div style="display: flex; justify-content: space-between; border-bottom: 1px solid black; padding-bottom: 2px;"> <span>SLV</span> <span>PGV</span> <span>PM SLV</span> <span>PM PGV</span> </div> <p>5.0 to 590.0 Hz</p>	50.0	-	Hz	page 5-19
F05	1st Rated Voltage at Base Frequency	<div style="display: flex; justify-content: space-between; border-bottom: 1px solid black; padding-bottom: 2px;"> <span>V/f</span> <span>DTV</span> <span>PG V/f</span> <span>PG DTV</span> </div> <div style="display: flex; justify-content: space-between; border-bottom: 1px solid black; padding-bottom: 2px;"> <span>SLV</span> <span>PGV</span> <span>PM SLV</span> <span>PM PGV</span> </div> <p>80 to 240 V: AVR operation (200 V class series)  160 to 500 V: AVR operation (400 V class series)</p>	200	-	V	page 5-19

Parameter No.	Function name	Monitor or Data Range	Default data	Setting during RUN	Unit	Page
F06	1st Rated Voltage at Maximum Output Frequency	<div style="display: flex; justify-content: space-between; border-bottom: 1px solid black; padding-bottom: 2px;"> <span>V/f</span> <span>DTV</span> <span>PG V/f</span> <span>PG DTV</span> </div> <div style="display: flex; justify-content: space-between; border-bottom: 1px solid black; padding-bottom: 2px;"> <span>SLV</span> <span>PGV</span> <span>PM SLV</span> <span>PM PGV</span> </div> 80 to 240 V: AVR operation (200 V class series) 160 to 500 V: AVR operation (400 V class series)	200	-	V	page 5-19
F07	1st Acceleration Time 1	<div style="display: flex; justify-content: space-between; border-bottom: 1px solid black; padding-bottom: 2px;"> <span>V/f</span> <span>DTV</span> <span>PG V/f</span> <span>PG DTV</span> </div> <div style="display: flex; justify-content: space-between; border-bottom: 1px solid black; padding-bottom: 2px;"> <span>SLV</span> <span>PGV</span> <span>PM SLV</span> <span>PM PGV</span> </div> 0.00 to 6000.00 s	6.00	Available	s	page 5-39
F08	1st Deceleration Time 1	<div style="display: flex; justify-content: space-between; border-bottom: 1px solid black; padding-bottom: 2px;"> <span>V/f</span> <span>DTV</span> <span>PG V/f</span> <span>PG DTV</span> </div> <div style="display: flex; justify-content: space-between; border-bottom: 1px solid black; padding-bottom: 2px;"> <span>SLV</span> <span>PGV</span> <span>PM SLV</span> <span>PM PGV</span> </div> 0.00 to 6000.00 s	6.00	Available	s	page 5-39
F09	1st Manual Torque Boost Voltage	<div style="display: flex; justify-content: space-between; border-bottom: 1px solid black; padding-bottom: 2px;"> <span>V/f</span> <span>DTV</span> <span>PG V/f</span> <span>PG DTV</span> </div> <div style="display: flex; justify-content: space-between; border-bottom: 1px solid black; padding-bottom: 2px;"> <span>SLV</span> <span>PGV</span> <span>PM SLV</span> <span>PM PGV</span> </div> 0.0 to 20.0 % Percentage of 1st Rated Voltage at Base Frequency(F05)	1.9	Available	%	page 5-73
F10	1st Motor Electronic Thermal Characteristic Selection	<div style="display: flex; justify-content: space-between; border-bottom: 1px solid black; padding-bottom: 2px;"> <span>V/f</span> <span>DTV</span> <span>PG V/f</span> <span>PG DTV</span> </div> <div style="display: flex; justify-content: space-between; border-bottom: 1px solid black; padding-bottom: 2px;"> <span>SLV</span> <span>PGV</span> <span>PM SLV</span> <span>PM PGV</span> </div> 1: For a general-purpose motor with shaft-driven cooling fan 2: For an inverter-driven motor non-ventilated motor or motor with separately powered cooling fan	1	Available	-	page 5-20
F11	1st Motor Electronic Thermal Level	<div style="display: flex; justify-content: space-between; border-bottom: 1px solid black; padding-bottom: 2px;"> <span>V/f</span> <span>DTV</span> <span>PG V/f</span> <span>PG DTV</span> </div> <div style="display: flex; justify-content: space-between; border-bottom: 1px solid black; padding-bottom: 2px;"> <span>SLV</span> <span>PGV</span> <span>PM SLV</span> <span>PM PGV</span> </div> 0.00 ; 0.01 to 118.8 0.00 : Disable 0.01 to 118.8 A  * Setting range from 1%(HHD) to 135%(ND) of the rated inverter current.	21	Available	A	page 5-20
F12	1st Motor Electronic Thermal Time Constant	<div style="display: flex; justify-content: space-between; border-bottom: 1px solid black; padding-bottom: 2px;"> <span>V/f</span> <span>DTV</span> <span>PG V/f</span> <span>PG DTV</span> </div> <div style="display: flex; justify-content: space-between; border-bottom: 1px solid black; padding-bottom: 2px;"> <span>SLV</span> <span>PGV</span> <span>PM SLV</span> <span>PM PGV</span> </div> 0.5 to 75.0 min	5	Available	min	page 5-20

Parameter No.	Function name	Monitor or Data Range	Default data	Setting during RUN	Unit	Page
F14	Power Interruption Restart Mode Selection	<div style="display: flex; justify-content: space-between; border-bottom: 1px solid black; padding-bottom: 2px;"> <span>V/f</span> <span>DTV</span> <span>PG V/f</span> <span>PG DTV</span> </div> <div style="display: flex; justify-content: space-between; border-bottom: 1px solid black; padding-bottom: 2px;"> <span>SLV</span> <span>PGV</span> <span>PM SLV</span> <span>PM PGV</span> </div> <p>0: Immediately trip(Free run stop)                      1: Trip after a recovery from power failure(Free run stop)                      2: Trip after decelerate-to-stop                      3: Continue to run                      4: Restart at the frequency selected by E152                      6: Decelerate-to-stop(w/o trip)</p>	1	Available	-	page 7-49
F15	1st Frequency Upper Limit	<div style="display: flex; justify-content: space-between; border-bottom: 1px solid black; padding-bottom: 2px;"> <span>V/f</span> <span>DTV</span> <span>PG V/f</span> <span>PG DTV</span> </div> <div style="display: flex; justify-content: space-between; border-bottom: 1px solid black; padding-bottom: 2px;"> <span>SLV</span> <span>PGV</span> <span>PM SLV</span> <span>PM PGV</span> </div> <p>0.00 to 590.00 Hz</p>	70.00	Available	Hz	page 5-32
F16	1st Frequency Lower Limit	<div style="display: flex; justify-content: space-between; border-bottom: 1px solid black; padding-bottom: 2px;"> <span>V/f</span> <span>DTV</span> <span>PG V/f</span> <span>PG DTV</span> </div> <div style="display: flex; justify-content: space-between; border-bottom: 1px solid black; padding-bottom: 2px;"> <span>SLV</span> <span>PGV</span> <span>PM SLV</span> <span>PM PGV</span> </div> <p>0.00 to 590.00 Hz</p>	0.00	Available	Hz	page 5-32
F18	Input Terminal [AI1, AI2] Bias for 1st Frequency Command	<div style="display: flex; justify-content: space-between; border-bottom: 1px solid black; padding-bottom: 2px;"> <span>V/f</span> <span>DTV</span> <span>PG V/f</span> <span>PG DTV</span> </div> <div style="display: flex; justify-content: space-between; border-bottom: 1px solid black; padding-bottom: 2px;"> <span>SLV</span> <span>PGV</span> <span>PM SLV</span> <span>PM PGV</span> </div> <p>-100.00 to 100.00 %</p>	0.00	Available	%	page 7-38
F20	1st DC Injection Braking Start Frequency	<div style="display: flex; justify-content: space-between; border-bottom: 1px solid black; padding-bottom: 2px;"> <span>V/f</span> <span>DTV</span> <span>PG V/f</span> <span>PG DTV</span> </div> <div style="display: flex; justify-content: space-between; border-bottom: 1px solid black; padding-bottom: 2px;"> <span>SLV</span> <span>PGV</span> <span style="background-color: #cccccc;">PM SLV</span> <span style="background-color: #cccccc;">PM PGV</span> </div> <p>0.0 to 60.0 Hz</p>	0.0	Available	Hz	page 7-63
F21	1st DC Injection Braking Level	<div style="display: flex; justify-content: space-between; border-bottom: 1px solid black; padding-bottom: 2px;"> <span>V/f</span> <span>DTV</span> <span>PG V/f</span> <span>PG DTV</span> </div> <div style="display: flex; justify-content: space-between; border-bottom: 1px solid black; padding-bottom: 2px;"> <span>SLV</span> <span>PGV</span> <span style="background-color: #cccccc;">PM SLV</span> <span style="background-color: #cccccc;">PM PGV</span> </div> <p>0 to 100% (HHD mode)                      0 to 80% (HND/HD mode)                      0 to 60% (ND mode)                      Based on inverter rated current</p>	0	Available	%	page 7-63
F22	1st DC Injection Braking Time	<div style="display: flex; justify-content: space-between; border-bottom: 1px solid black; padding-bottom: 2px;"> <span>V/f</span> <span>DTV</span> <span>PG V/f</span> <span>PG DTV</span> </div> <div style="display: flex; justify-content: space-between; border-bottom: 1px solid black; padding-bottom: 2px;"> <span>SLV</span> <span>PGV</span> <span style="background-color: #cccccc;">PM SLV</span> <span style="background-color: #cccccc;">PM PGV</span> </div> <p>0.00: Disable                      0.01 to 30.00 s</p>	0.00	Available	s	page 7-63
F23	1st Starting Frequency	<div style="display: flex; justify-content: space-between; border-bottom: 1px solid black; padding-bottom: 2px;"> <span>V/f</span> <span>DTV</span> <span>PG V/f</span> <span>PG DTV</span> </div> <div style="display: flex; justify-content: space-between; border-bottom: 1px solid black; padding-bottom: 2px;"> <span>SLV</span> <span>PGV</span> <span>PM SLV</span> <span>PM PGV</span> </div> <p>0.0 to 60.0 Hz</p>	0.5	Available	Hz	page 7-114
F24	1st Starting Frequency (Holding time)	<div style="display: flex; justify-content: space-between; border-bottom: 1px solid black; padding-bottom: 2px;"> <span>V/f</span> <span>DTV</span> <span>PG V/f</span> <span>PG DTV</span> </div> <div style="display: flex; justify-content: space-between; border-bottom: 1px solid black; padding-bottom: 2px;"> <span>SLV</span> <span>PGV</span> <span>PM SLV</span> <span>PM PGV</span> </div> <p>0.00 to 10.00 s</p>	0.00	Available	s	page 7-114

Parameter No.	Function name	Monitor or Data Range	Default data	Setting during RUN	Unit	Page
F25	1st Stop Frequency	<div style="display: flex; justify-content: space-between; border-bottom: 1px solid black; padding-bottom: 2px;"> <span>V/f</span> <span>DTV</span> <span>PG V/f</span> <span>PG DTV</span> </div> <div style="display: flex; justify-content: space-between; border-bottom: 1px solid black; padding-bottom: 2px;"> <span>SLV</span> <span>PGV</span> <span>PM SLV</span> <span>PM PGV</span> </div> 0.0 to 60.0 Hz	0.2	Available	Hz	page 7-114
F26	Carrier Frequency	<div style="display: flex; justify-content: space-between; border-bottom: 1px solid black; padding-bottom: 2px;"> <span>V/f</span> <span>DTV</span> <span>PG V/f</span> <span>PG DTV</span> </div> <div style="display: flex; justify-content: space-between; border-bottom: 1px solid black; padding-bottom: 2px;"> <span>SLV</span> <span>PGV</span> <span>PM SLV</span> <span>PM PGV</span> </div> 0: 0.75 kHz 1: 1 kHz 2: 2 kHz 3: 3 kHz 4: 4 kHz 5: 5 kHz 6: 6 kHz 7: 7 kHz 8: 8 kHz 9: 9 kHz 10: 10 kHz 11: 11 kHz 12: 12 kHz 13: 13 kHz 14: 14 kHz 15: 15 kHz 16: 16 kHz	2	Available	kHz	page 7-113
F27	Motor Sound Tone	<div style="display: flex; justify-content: space-between; border-bottom: 1px solid black; padding-bottom: 2px;"> <span>V/f</span> <span>DTV</span> <span>PG V/f</span> <span>PG DTV</span> </div> <div style="display: flex; justify-content: space-between; border-bottom: 1px solid black; padding-bottom: 2px;"> <span>SLV</span> <span>PGV</span> <span>PM SLV</span> <span>PM PGV</span> </div> 0: Level 0 (Disable) 1: Level 1 2: Level 2 3: Level 3	0	Available	-	page 7-113
F29	Output Terminal [AO] Mode Selection	<div style="display: flex; justify-content: space-between; border-bottom: 1px solid black; padding-bottom: 2px;"> <span>V/f</span> <span>DTV</span> <span>PG V/f</span> <span>PG DTV</span> </div> <div style="display: flex; justify-content: space-between; border-bottom: 1px solid black; padding-bottom: 2px;"> <span>SLV</span> <span>PGV</span> <span>PM SLV</span> <span>PM PGV</span> </div> 0: Output in voltage (0 to 10 VDC) 1: Output in current (4 to 20mADC) 2: Output in current (0 to 20mADC) 3: Pulse output	0	Available	-	page 7-46
F30	Output Terminal [AO] Gain	<div style="display: flex; justify-content: space-between; border-bottom: 1px solid black; padding-bottom: 2px;"> <span>V/f</span> <span>DTV</span> <span>PG V/f</span> <span>PG DTV</span> </div> <div style="display: flex; justify-content: space-between; border-bottom: 1px solid black; padding-bottom: 2px;"> <span>SLV</span> <span>PGV</span> <span>PM SLV</span> <span>PM PGV</span> </div> 0 to 300 %	100	Available	%	page 7-46

Parameter No.	Function name	Monitor or Data Range	Default data	Setting during RUN	Unit	Page
F31	Output Terminal [AO] Function Selection	<div style="display: flex; justify-content: space-between; border-bottom: 1px solid black; padding-bottom: 2px;"> <span>V/f</span> <span>DTV</span> <span>PG V/f</span> <span>PG DTV</span> </div> <div style="display: flex; justify-content: space-between; border-bottom: 1px solid black; padding-bottom: 2px;"> <span>SLV</span> <span>PGV</span> <span>PM SLV</span> <span>PM PGV</span> </div> <p>0: Output frequency1 (before slip compensation)  1: Output frequency2 (after slip compensation)  2: Output current  3: Output voltage  4: Output torque  5: Load ratio  6: Power consumption  7: PID feedback  8: Actual/Estimated speed  9: Main Circuit DC Voltage  10: Communication data AO  13: Motor output  14: Calibration (+)  15: PID command (SV)  16: PID output (MV)  17: Position error in master-follower operation (Bipolar)  18: Heatsink temperature  21: PG feedback value  27: Thermal load ratio  28: Internal Acc/Dec frequency  29: Output torque (Bipolar)</p>	0	Available	-	page 7-46
F33	Output Terminal [AO] Pulse Rate (PO)	<div style="display: flex; justify-content: space-between; border-bottom: 1px solid black; padding-bottom: 2px;"> <span>V/f</span> <span>DTV</span> <span>PG V/f</span> <span>PG DTV</span> </div> <div style="display: flex; justify-content: space-between; border-bottom: 1px solid black; padding-bottom: 2px;"> <span>SLV</span> <span>PGV</span> <span>PM SLV</span> <span>PM PGV</span> </div> <p>25 to 32000 p/s  Pulse rate at 100% output</p>	1440	Available	p/s	page 7-46
F37	1st V/f Characteristics Selection	<div style="display: flex; justify-content: space-between; border-bottom: 1px solid black; padding-bottom: 2px;"> <span>V/f</span> <span>DTV</span> <span>PG V/f</span> <span>PG DTV</span> </div> <div style="display: flex; justify-content: space-between; border-bottom: 1px solid black; padding-bottom: 2px;"> <span>SLV</span> <span>PGV</span> <span>PM SLV</span> <span>PM PGV</span> </div> <p>0: Variable torque load  1: Constant torque load</p>	1	-	-	page 5-10
F38	1st Overload Early Warning Detection Timer / Low Current detection level (OL, LOC)	<div style="display: flex; justify-content: space-between; border-bottom: 1px solid black; padding-bottom: 2px;"> <span>V/f</span> <span>DTV</span> <span>PG V/f</span> <span>PG DTV</span> </div> <div style="display: flex; justify-content: space-between; border-bottom: 1px solid black; padding-bottom: 2px;"> <span>SLV</span> <span>PGV</span> <span>PM SLV</span> <span>PM PGV</span> </div> <p>0: Detected/Estimated speed  1: Reference speed</p>	0	-	-	page 7-114
F39	Display Coefficient 1 for Transport Time / Auxiliary Display Coefficient 1 for Speed Monitor	<div style="display: flex; justify-content: space-between; border-bottom: 1px solid black; padding-bottom: 2px;"> <span>V/f</span> <span>DTV</span> <span>PG V/f</span> <span>PG DTV</span> </div> <div style="display: flex; justify-content: space-between; border-bottom: 1px solid black; padding-bottom: 2px;"> <span>SLV</span> <span>PGV</span> <span>PM SLV</span> <span>PM PGV</span> </div> <p>0.00 to 10.00 s</p>	0.00	Available	s	page 7-114
F40	Torque Limit 1	<div style="display: flex; justify-content: space-between; border-bottom: 1px solid black; padding-bottom: 2px;"> <span>V/f</span> <span>DTV</span> <span>PG V/f</span> <span>PG DTV</span> </div> <div style="display: flex; justify-content: space-between; border-bottom: 1px solid black; padding-bottom: 2px;"> <span>SLV</span> <span>PGV</span> <span>PM SLV</span> <span>PM PGV</span> </div> <p>0 to 300 %</p>	300	Available	%	page 6-81



Parameter No.	Function name	Monitor or Data Range	Default data	Setting during RUN	Unit	Page
F41	Torque Limit 2	<div style="display: flex; justify-content: space-between; border-bottom: 1px solid black; padding-bottom: 2px;"> <span>V/f</span> <span>DTV</span> <span>PG V/f</span> <span>PG DTV</span> </div> <div style="display: flex; justify-content: space-between; border-bottom: 1px solid black; padding-bottom: 2px;"> <span>SLV</span> <span>PGV</span> <span>PM SLV</span> <span>PM PGV</span> </div> 0 to 300 %	300	Available	%	page 6-81
F42	1st Drive Control Selection	<div style="display: flex; justify-content: space-between; border-bottom: 1px solid black; padding-bottom: 2px;"> <span>V/f</span> <span>DTV</span> <span>PG V/f</span> <span>PG DTV</span> </div> <div style="display: flex; justify-content: space-between; border-bottom: 1px solid black; padding-bottom: 2px;"> <span>SLV</span> <span>PGV</span> <span>PM SLV</span> <span>PM PGV</span> </div> 0 to 16 0 : IM V/f control 1 : IM Dynamic torque vector control 3 : IM V/f control with speed sensor 4 : IM Dynamic torque vector control with speed sensor 5 : IM Vector control without speed sensor 6 : IM Vector control with speed sensor 15 : PM Vector control without speed and pole position sensor 16 : PM Vector control with speed and pole position sensor	0	-	-	page 5-10 page 6-16 page 6-11 page 6-21
F43	1st Overload Protect Function Selection	<div style="display: flex; justify-content: space-between; border-bottom: 1px solid black; padding-bottom: 2px;"> <span>V/f</span> <span>DTV</span> <span>PG V/f</span> <span>PG DTV</span> </div> <div style="display: flex; justify-content: space-between; border-bottom: 1px solid black; padding-bottom: 2px;"> <span>SLV</span> <span>PGV</span> <span>PM SLV</span> <span>PM PGV</span> </div> 0: Disable 1: Enable at constant speed 2: Enable during ACC/constant speed operation	2	Available	-	page 7-82
F44	1st Overload Protect Level	<div style="display: flex; justify-content: space-between; border-bottom: 1px solid black; padding-bottom: 2px;"> <span>V/f</span> <span>DTV</span> <span>PG V/f</span> <span>PG DTV</span> </div> <div style="display: flex; justify-content: space-between; border-bottom: 1px solid black; padding-bottom: 2px;"> <span>SLV</span> <span>PGV</span> <span>PM SLV</span> <span>PM PGV</span> </div> 20 to 200% 100% = Rated output current of inverter (Default: 180% for HHD mode and 130% for ND mode)	180	Available	%	page 7-82
F50	Electronic Thermal for Braking Resistor Discharging Capacity	<div style="display: flex; justify-content: space-between; border-bottom: 1px solid black; padding-bottom: 2px;"> <span>V/f</span> <span>DTV</span> <span>PG V/f</span> <span>PG DTV</span> </div> <div style="display: flex; justify-content: space-between; border-bottom: 1px solid black; padding-bottom: 2px;"> <span>SLV</span> <span>PGV</span> <span>PM SLV</span> <span>PM PGV</span> </div> 1 to 9,000 kW 32,767: Disable	32767	Available	kWs	page 5-75
F51	Electronic Thermal for Braking Resistor Allowable Average Loss	<div style="display: flex; justify-content: space-between; border-bottom: 1px solid black; padding-bottom: 2px;"> <span>V/f</span> <span>DTV</span> <span>PG V/f</span> <span>PG DTV</span> </div> <div style="display: flex; justify-content: space-between; border-bottom: 1px solid black; padding-bottom: 2px;"> <span>SLV</span> <span>PGV</span> <span>PM SLV</span> <span>PM PGV</span> </div> 0.001 to 99.99 kW	0.001	Available	kW	page 5-75

Parameter No.	Function name	Monitor or Data Range	Default data	Setting during RUN	Unit	Page
F52	Braking Resistor Resistance	<div style="display: flex; justify-content: space-between; border-bottom: 1px solid black; padding-bottom: 2px;"> <span>V/f</span> <span>DTV</span> <span>PG V/f</span> <span>PG DTV</span> </div> <div style="display: flex; justify-content: space-between; border-bottom: 1px solid black; padding-bottom: 2px;"> <span>SLV</span> <span>PGV</span> <span>PM SLV</span> <span>PM PGV</span> </div> 0.01 to 999 Ω	0.01	Available	ohm	page 5-75
F58	Output Terminal [AO] Filter	<div style="display: flex; justify-content: space-between; border-bottom: 1px solid black; padding-bottom: 2px;"> <span>V/f</span> <span>DTV</span> <span>PG V/f</span> <span>PG DTV</span> </div> <div style="display: flex; justify-content: space-between; border-bottom: 1px solid black; padding-bottom: 2px;"> <span>SLV</span> <span>PGV</span> <span>PM SLV</span> <span>PM PGV</span> </div> 0.00 to 5.00 s	0.00	Available	s	page 7-46
F59	Output Terminal [AO] Bias	<div style="display: flex; justify-content: space-between; border-bottom: 1px solid black; padding-bottom: 2px;"> <span>V/f</span> <span>DTV</span> <span>PG V/f</span> <span>PG DTV</span> </div> <div style="display: flex; justify-content: space-between; border-bottom: 1px solid black; padding-bottom: 2px;"> <span>SLV</span> <span>PGV</span> <span>PM SLV</span> <span>PM PGV</span> </div> -100.0 to 100.0 %	0.0	Available	%	page 7-46
F80	Load Mode Selection	<div style="display: flex; justify-content: space-between; border-bottom: 1px solid black; padding-bottom: 2px;"> <span>V/f</span> <span>DTV</span> <span>PG V/f</span> <span>PG DTV</span> </div> <div style="display: flex; justify-content: space-between; border-bottom: 1px solid black; padding-bottom: 2px;"> <span>SLV</span> <span>PGV</span> <span>PM SLV</span> <span>PM PGV</span> </div> 0: HHD 1: HND 3: HD (only for 400 V) 4: ND (only for 400 V)	0	-	-	page 5-12

#### 4-2-2 Parameter E (Terminal Functions)

Parameter No.	Function name	Monitor or Data Range	Default data	Setting during RUN	Unit	Page
E01	Input Terminal [DI1] Function Selection	<div style="display: flex; justify-content: space-between; border-bottom: 1px solid black; padding-bottom: 2px;"> <span>V/f</span> <span>DTV</span> <span>PG V/f</span> <span>PG DTV</span> </div> <div style="display: flex; justify-content: space-between; border-bottom: 1px solid black; padding-bottom: 2px;"> <span>SLV</span> <span>PGV</span> <span>PM SLV</span> <span>PM PGV</span> </div> 0 to 188 normally-open input, 1000 to 1188 normally-close input	0	-	-	page 7-26
E02	Input Terminal [DI2] Function Selection	<div style="display: flex; justify-content: space-between; border-bottom: 1px solid black; padding-bottom: 2px;"> <span>V/f</span> <span>DTV</span> <span>PG V/f</span> <span>PG DTV</span> </div> <div style="display: flex; justify-content: space-between; border-bottom: 1px solid black; padding-bottom: 2px;"> <span>SLV</span> <span>PGV</span> <span>PM SLV</span> <span>PM PGV</span> </div> 0 to 188 normally-open input, 1000 to 1188 normally-close input	1	-	-	page 7-26
E03	Input Terminal [DI3] Function Selection	<div style="display: flex; justify-content: space-between; border-bottom: 1px solid black; padding-bottom: 2px;"> <span>V/f</span> <span>DTV</span> <span>PG V/f</span> <span>PG DTV</span> </div> <div style="display: flex; justify-content: space-between; border-bottom: 1px solid black; padding-bottom: 2px;"> <span>SLV</span> <span>PGV</span> <span>PM SLV</span> <span>PM PGV</span> </div> 0 to 188 normally-open input, 1000 to 1188 normally-close input	2	-	-	page 7-26
E04	Input Terminal [DI4] Function Selection	<div style="display: flex; justify-content: space-between; border-bottom: 1px solid black; padding-bottom: 2px;"> <span>V/f</span> <span>DTV</span> <span>PG V/f</span> <span>PG DTV</span> </div> <div style="display: flex; justify-content: space-between; border-bottom: 1px solid black; padding-bottom: 2px;"> <span>SLV</span> <span>PGV</span> <span>PM SLV</span> <span>PM PGV</span> </div> 0 to 188 normally-open input, 1000 to 1188 normally-close input	7	-	-	page 7-26

Parameter No.	Function name	Monitor or Data Range	Default data	Setting during RUN	Unit	Page
E05	Input Terminal [DI5] Function Selection	<div style="display: flex; justify-content: space-between; border-bottom: 1px solid black; padding-bottom: 2px;"> <span>V/f</span> <span>DTV</span> <span>PG V/f</span> <span>PG DTV</span> </div> <div style="display: flex; justify-content: space-between; border-bottom: 1px solid black; padding-bottom: 2px;"> <span>SLV</span> <span>PGV</span> <span>PM SLV</span> <span>PM PGV</span> </div> 0 to 188 normally-open input, 1000 to 1188 normally-close input	8	-	-	page 7-26
E10	2nd Acceleration Time 1	<div style="display: flex; justify-content: space-between; border-bottom: 1px solid black; padding-bottom: 2px;"> <span>V/f</span> <span>DTV</span> <span>PG V/f</span> <span>PG DTV</span> </div> <div style="display: flex; justify-content: space-between; border-bottom: 1px solid black; padding-bottom: 2px;"> <span>SLV</span> <span>PGV</span> <span>PM SLV</span> <span>PM PGV</span> </div> 0.00 to 6000.00 s	6.00	Available	s	page 5-39 page 5-43
E11	2nd Deceleration Time 1	<div style="display: flex; justify-content: space-between; border-bottom: 1px solid black; padding-bottom: 2px;"> <span>V/f</span> <span>DTV</span> <span>PG V/f</span> <span>PG DTV</span> </div> <div style="display: flex; justify-content: space-between; border-bottom: 1px solid black; padding-bottom: 2px;"> <span>SLV</span> <span>PGV</span> <span>PM SLV</span> <span>PM PGV</span> </div> 0.00 to 6000.00 s	6.00	Available	s	page 5-39 page 5-43
E12	1st Acceleration Time 2	<div style="display: flex; justify-content: space-between; border-bottom: 1px solid black; padding-bottom: 2px;"> <span>V/f</span> <span>DTV</span> <span>PG V/f</span> <span>PG DTV</span> </div> <div style="display: flex; justify-content: space-between; border-bottom: 1px solid black; padding-bottom: 2px;"> <span>SLV</span> <span>PGV</span> <span>PM SLV</span> <span>PM PGV</span> </div> 0.00 to 6000.00 s	6.00	Available	s	page 5-43
E13	1st Deceleration Time 1	<div style="display: flex; justify-content: space-between; border-bottom: 1px solid black; padding-bottom: 2px;"> <span>V/f</span> <span>DTV</span> <span>PG V/f</span> <span>PG DTV</span> </div> <div style="display: flex; justify-content: space-between; border-bottom: 1px solid black; padding-bottom: 2px;"> <span>SLV</span> <span>PGV</span> <span>PM SLV</span> <span>PM PGV</span> </div> 0.00 to 6000.00 s	6.00	Available	s	page 5-43
E14	2nd Acceleration Time 2	<div style="display: flex; justify-content: space-between; border-bottom: 1px solid black; padding-bottom: 2px;"> <span>V/f</span> <span>DTV</span> <span>PG V/f</span> <span>PG DTV</span> </div> <div style="display: flex; justify-content: space-between; border-bottom: 1px solid black; padding-bottom: 2px;"> <span>SLV</span> <span>PGV</span> <span>PM SLV</span> <span>PM PGV</span> </div> 0.00 to 6000.00 s	6.00	Available	s	page 5-43
E15	2nd Deceleration Time 2	<div style="display: flex; justify-content: space-between; border-bottom: 1px solid black; padding-bottom: 2px;"> <span>V/f</span> <span>DTV</span> <span>PG V/f</span> <span>PG DTV</span> </div> <div style="display: flex; justify-content: space-between; border-bottom: 1px solid black; padding-bottom: 2px;"> <span>SLV</span> <span>PGV</span> <span>PM SLV</span> <span>PM PGV</span> </div> 0.00 to 6000.00 s	6.00	Available	s	page 5-43
E16	Torque Limit 3	<div style="display: flex; justify-content: space-between; border-bottom: 1px solid black; padding-bottom: 2px;"> <span>V/f</span> <span>DTV</span> <span>PG V/f</span> <span>PG DTV</span> </div> <div style="display: flex; justify-content: space-between; border-bottom: 1px solid black; padding-bottom: 2px;"> <span>SLV</span> <span>PGV</span> <span>PM SLV</span> <span>PM PGV</span> </div> 0 to 300 %	300	Available	%	page 6-81
E17	Torque Limit 4	<div style="display: flex; justify-content: space-between; border-bottom: 1px solid black; padding-bottom: 2px;"> <span>V/f</span> <span>DTV</span> <span>PG V/f</span> <span>PG DTV</span> </div> <div style="display: flex; justify-content: space-between; border-bottom: 1px solid black; padding-bottom: 2px;"> <span>SLV</span> <span>PGV</span> <span>PM SLV</span> <span>PM PGV</span> </div> 0 to 300 %	300	Available	%	page 6-81
E20	Output Terminal [DO1] Function Selection	<div style="display: flex; justify-content: space-between; border-bottom: 1px solid black; padding-bottom: 2px;"> <span>V/f</span> <span>DTV</span> <span>PG V/f</span> <span>PG DTV</span> </div> <div style="display: flex; justify-content: space-between; border-bottom: 1px solid black; padding-bottom: 2px;"> <span>SLV</span> <span>PGV</span> <span>PM SLV</span> <span>PM PGV</span> </div> 0 to 241 normally-open output, 1000 to 1241 normally-close output Refer to the manual for the contents of function assign- ment.	0	-	-	page 7-31

Parameter No.	Function name	Monitor or Data Range	Default data	Setting during RUN	Unit	Page
E21	Output Terminal [DO2] Function Selection	<div style="display: flex; justify-content: space-between; margin-bottom: 5px;"> <span>V/f</span> <span>DTV</span> <span>PG V/f</span> <span>PG DTV</span> </div> <div style="display: flex; justify-content: space-between; margin-bottom: 5px;"> <span>SLV</span> <span>PGV</span> <span>PM SLV</span> <span>PM PGV</span> </div> 0 to 241 normally-open output, 1000 to 1241 normally-close output Refer to the manual for the contents of function assignment.	7	-	-	page 7-31
E27	Output Terminal [ROA, ROB] Function Selection	<div style="display: flex; justify-content: space-between; margin-bottom: 5px;"> <span>V/f</span> <span>DTV</span> <span>PG V/f</span> <span>PG DTV</span> </div> <div style="display: flex; justify-content: space-between; margin-bottom: 5px;"> <span>SLV</span> <span>PGV</span> <span>PM SLV</span> <span>PM PGV</span> </div> 0 to 241 normally-open output, 1000 to 1241 normally-close output Refer to the manual for the contents of function assignment.	99	-	-	page 7-31
E29	Frequency Arrival 2 ON Timer	<div style="display: flex; justify-content: space-between; margin-bottom: 5px;"> <span>V/f</span> <span>DTV</span> <span>PG V/f</span> <span>PG DTV</span> </div> <div style="display: flex; justify-content: space-between; margin-bottom: 5px;"> <span>SLV</span> <span>PGV</span> <span>PM SLV</span> <span>PM PGV</span> </div> 0.01 to 10.00 s	0.1	Available	s	page 7-89
E30	Frequency Arrival Detection Width (FAR1/FAR2/FAR3/FDT3/FDT4)	<div style="display: flex; justify-content: space-between; margin-bottom: 5px;"> <span>V/f</span> <span>DTV</span> <span>PG V/f</span> <span>PG DTV</span> </div> <div style="display: flex; justify-content: space-between; margin-bottom: 5px;"> <span>SLV</span> <span>PGV</span> <span>PM SLV</span> <span>PM PGV</span> </div> 0.0 to 10.0 Hz	2.5	Available	Hz	page 7-89
E31	Frequency Detection Level1 (FDT1/FDT3)	<div style="display: flex; justify-content: space-between; margin-bottom: 5px;"> <span>V/f</span> <span>DTV</span> <span>PG V/f</span> <span>PG DTV</span> </div> <div style="display: flex; justify-content: space-between; margin-bottom: 5px;"> <span>SLV</span> <span>PGV</span> <span>PM SLV</span> <span>PM PGV</span> </div> 0.0 to 590.0 Hz	60.0	Available	Hz	page 7-89
E32	Frequency Detection Hysteresis Width (FDT1/ FDT2)	<div style="display: flex; justify-content: space-between; margin-bottom: 5px;"> <span>V/f</span> <span>DTV</span> <span>PG V/f</span> <span>PG DTV</span> </div> <div style="display: flex; justify-content: space-between; margin-bottom: 5px;"> <span>SLV</span> <span>PGV</span> <span>PM SLV</span> <span>PM PGV</span> </div> 0.0 to 590.0 Hz	1	Available	Hz	page 7-89
E34	Overload early warning 2 Level (OL2)	<div style="display: flex; justify-content: space-between; margin-bottom: 5px;"> <span>V/f</span> <span>DTV</span> <span>PG V/f</span> <span>PG DTV</span> </div> <div style="display: flex; justify-content: space-between; margin-bottom: 5px;"> <span>SLV</span> <span>PGV</span> <span>PM SLV</span> <span>PM PGV</span> </div> 0.00 ; 0.01 to 176.0 0.00 : Disable 0.01 to 176.0 A  * Setting range from 1%(HHD) to 200%(ND) of the rated inverter current.	21	Available	A	page 5-23 page 7-82
E35	Overload early warning 2 Detection Timer (OL2)	<div style="display: flex; justify-content: space-between; margin-bottom: 5px;"> <span>V/f</span> <span>DTV</span> <span>PG V/f</span> <span>PG DTV</span> </div> <div style="display: flex; justify-content: space-between; margin-bottom: 5px;"> <span>SLV</span> <span>PGV</span> <span>PM SLV</span> <span>PM PGV</span> </div> 0.01 to 600.00 s	10	Available	s	page 7-82

Parameter No.	Function name	Monitor or Data Range	Default data	Setting during RUN	Unit	Page
E36	Frequency Detection Level 2 (FDT2/FDT4)	<div style="display: flex; justify-content: space-between; border-bottom: 1px solid black; margin-bottom: 5px;"> <span>V/f</span> <span>DTV</span> <span>PG V/f</span> <span>PG DTV</span> </div> <div style="display: flex; justify-content: space-between; border-bottom: 1px solid black; margin-bottom: 5px;"> <span>SLV</span> <span>PGV</span> <span>PM SLV</span> <span>PM PGV</span> </div> 0.0 to 590.0 Hz	60.0	Available	Hz	page 7-89
E37	1st Overload Early Warning Detection Level	<div style="display: flex; justify-content: space-between; border-bottom: 1px solid black; margin-bottom: 5px;"> <span>V/f</span> <span>DTV</span> <span>PG V/f</span> <span>PG DTV</span> </div> <div style="display: flex; justify-content: space-between; border-bottom: 1px solid black; margin-bottom: 5px;"> <span>SLV</span> <span>PGV</span> <span>PM SLV</span> <span>PM PGV</span> </div> 0.00 ; 0.01 to 176.0 0.00 : Disable 0.01 to 176.0 A  * Setting range from 1%(HHD) to 200%(ND) of the rated inverter current.	21	Available	A	page 7-82
E38	1st Overload Early Warning Detection Timer / Low Current detection level (OL, LOC)	<div style="display: flex; justify-content: space-between; border-bottom: 1px solid black; margin-bottom: 5px;"> <span>V/f</span> <span>DTV</span> <span>PG V/f</span> <span>PG DTV</span> </div> <div style="display: flex; justify-content: space-between; border-bottom: 1px solid black; margin-bottom: 5px;"> <span>SLV</span> <span>PGV</span> <span>PM SLV</span> <span>PM PGV</span> </div> 0.01 to 600.00 s	10	Available	s	page 7-82
E39	Display Coefficient 1 for Transport Time / Auxiliary Display Coefficient 1 for Speed Monitor	<div style="display: flex; justify-content: space-between; border-bottom: 1px solid black; margin-bottom: 5px;"> <span>V/f</span> <span>DTV</span> <span>PG V/f</span> <span>PG DTV</span> </div> <div style="display: flex; justify-content: space-between; border-bottom: 1px solid black; margin-bottom: 5px;"> <span>SLV</span> <span>PGV</span> <span>PM SLV</span> <span>PM PGV</span> </div> 0.000 to 9999	1	Available	-	page 7-76
E42	Operator Display Filter	<div style="display: flex; justify-content: space-between; border-bottom: 1px solid black; margin-bottom: 5px;"> <span>V/f</span> <span>DTV</span> <span>PG V/f</span> <span>PG DTV</span> </div> <div style="display: flex; justify-content: space-between; border-bottom: 1px solid black; margin-bottom: 5px;"> <span>SLV</span> <span>PGV</span> <span>PM SLV</span> <span>PM PGV</span> </div> 0.0 to 5.0 s	0.5	Available	s	page 3-3

Parameter No.	Function name	Monitor or Data Range	Default data	Setting during RUN	Unit	Page
E43	Operator Display Selection during Run	<p>V/f DTV PG V/f PG DTV</p> <p>SLV PGV PM SLV PM PGV</p> <p>0: Speed monitor (Selectable with E048)            3: Output current            4: Output voltage            8: Calculated torque            9: Input power            10: PID process command            12: PID feedback            13: Timer value            14: PID output            15: Load factor            16: Motor output            17: Analog signal input monitor            21: Current position            22: Position error            23: Torque current (%)            24: Magnetic flux command (%)            25: Input watt-hour            28: Target position            29: PID deviation            30: Torque bias            32: Reserved</p>	0	Available	-	page 7-76
E44	Operator Display when Stopped Selection	<p>V/f DTV PG V/f PG DTV</p> <p>SLV PGV PM SLV PM PGV</p> <p>0: Specified value            1: Output value</p>	0	Available	-	page 7-76
E48	Operator Display Speed Monitor Item Selection	<p>V/f DTV PG V/f PG DTV</p> <p>SLV PGV PM SLV PM PGV</p> <p>0: Output frequency 1 (Before slip compensation)            1: Output frequency 2 (After slip compensation)            2: Reference frequency            3: Motor rotation speed            4: Load rotation speed            5: Feed speed            6: Transport time for specified length            7: Speed (%)</p>	0	Available	-	page 7-76
E49	Torque Command Monitor Polarity Selection	<p>V/f DTV PG V/f PG DTV</p> <p>SLV PGV PM SLV PM PGV</p> <p>0: Torque polarity            1: Plus for driving Minus for braking</p>	1	Available	-	page 6-83

Parameter No.	Function name	Monitor or Data Range	Default data	Setting during RUN	Unit	Page
E50	1st Frequency Conversion Coefficient	<div style="display: flex; justify-content: space-between; border-bottom: 1px solid black; padding-bottom: 2px;"> <span>V/f</span> <span>DTV</span> <span>PG V/f</span> <span>PG DTV</span> </div> <div style="display: flex; justify-content: space-between; border-bottom: 1px solid black; padding-bottom: 2px;"> <span>SLV</span> <span>PGV</span> <span>PM SLV</span> <span>PM PGV</span> </div> 0.01 to 600.00	30	Available	-	page 6-78 page 7-76
E51	Display Coefficient for Integrated Power	<div style="display: flex; justify-content: space-between; border-bottom: 1px solid black; padding-bottom: 2px;"> <span>V/f</span> <span>DTV</span> <span>PG V/f</span> <span>PG DTV</span> </div> <div style="display: flex; justify-content: space-between; border-bottom: 1px solid black; padding-bottom: 2px;"> <span>SLV</span> <span>PGV</span> <span>PM SLV</span> <span>PM PGV</span> </div> 0.000: Cancel and reset 0.001 to 9999	0.01	Available	-	page 7-13
E52	Operator Display Selection	<div style="display: flex; justify-content: space-between; border-bottom: 1px solid black; padding-bottom: 2px;"> <span>V/f</span> <span>DTV</span> <span>PG V/f</span> <span>PG DTV</span> </div> <div style="display: flex; justify-content: space-between; border-bottom: 1px solid black; padding-bottom: 2px;"> <span>SLV</span> <span>PGV</span> <span>PM SLV</span> <span>PM PGV</span> </div> 0: Display favorite parameters and all parameters 1: Display change parameters 2: Display all parameters	2	Available	-	page 5-3
E55	2nd Overload Warning Detection Level	<div style="display: flex; justify-content: space-between; border-bottom: 1px solid black; padding-bottom: 2px;"> <span>V/f</span> <span>DTV</span> <span>PG V/f</span> <span>PG DTV</span> </div> <div style="display: flex; justify-content: space-between; border-bottom: 1px solid black; padding-bottom: 2px;"> <span>SLV</span> <span>PGV</span> <span>PM SLV</span> <span>PM PGV</span> </div> 0.00 ; 0.01 to 176.0 0.00 : Disable 0.01 to 176.0 A  * Setting range from 1%(HHD) to 200%(ND) of the rated inverter current.	21	Available	A	page 7-82
E56	2nd Overload Early Warning Detection Timer	<div style="display: flex; justify-content: space-between; border-bottom: 1px solid black; padding-bottom: 2px;"> <span>V/f</span> <span>DTV</span> <span>PG V/f</span> <span>PG DTV</span> </div> <div style="display: flex; justify-content: space-between; border-bottom: 1px solid black; padding-bottom: 2px;"> <span>SLV</span> <span>PGV</span> <span>PM SLV</span> <span>PM PGV</span> </div> 0.00 to 600.00 s	10	Available	s	page 7-82
E61	Input Terminal [AI1] Function Selection	<div style="display: flex; justify-content: space-between; border-bottom: 1px solid black; padding-bottom: 2px;"> <span>V/f</span> <span>DTV</span> <span>PG V/f</span> <span>PG DTV</span> </div> <div style="display: flex; justify-content: space-between; border-bottom: 1px solid black; padding-bottom: 2px;"> <span>SLV</span> <span>PGV</span> <span>PM SLV</span> <span>PM PGV</span> </div> 0: Frequency command 1: Auxiliary frequency setting 1 2: Auxiliary frequency setting 2 3: PID command 5: PID feedback 6: Ratio setting 7: Analog torque limiter 9: Torque bias 10: Torque command 11: Torque current command 17: Speed limit for forward rotation 18: Speed limit for reverse rotation 20: Analog signal input monitor 21: PID feed forward	0	-	-	page 6-81

Parameter No.	Function name	Monitor or Data Range	Default data	Setting during RUN	Unit	Page
E62	Input Terminal [AI2] Function Selection (All)	<div style="display: flex; justify-content: space-between; border-bottom: 1px solid black; padding-bottom: 2px;"> <span>V/f</span> <span>DTV</span> <span>PG V/f</span> <span>PG DTV</span> </div> <div style="display: flex; justify-content: space-between; border-bottom: 1px solid black; padding-bottom: 2px;"> <span>SLV</span> <span>PGV</span> <span>PM SLV</span> <span>PM PGV</span> </div> <p>0: Frequency command  1: Auxiliary frequency setting 1  2: Auxiliary frequency setting 2  3: PID process command  5: PID feedback value  6: Ratio setting  7: Analog torque limiter  9: Torque bias  10: Torque command  11: Torque current command  17: Speed limit for forward rotation  18: Speed limit for reverse rotation  20: Analog signal input monitor  21: PID feed forward</p>	0	-	-	page 6-81
E63	Input Terminal [AI2] Function Selection (AIV)	<div style="display: flex; justify-content: space-between; border-bottom: 1px solid black; padding-bottom: 2px;"> <span>V/f</span> <span>DTV</span> <span>PG V/f</span> <span>PG DTV</span> </div> <div style="display: flex; justify-content: space-between; border-bottom: 1px solid black; padding-bottom: 2px;"> <span>SLV</span> <span>PGV</span> <span>PM SLV</span> <span>PM PGV</span> </div> <p>0: Frequency command  1: Auxiliary frequency setting 1  2: Auxiliary frequency setting 2  3: PID command  5: PID feedback  6: Ratio setting  7: Analog torque limiter  9: Torque bias  10: Torque command  11: Torque current command  17: Speed limit for forward rotation  18: Speed limit for reverse rotation  20: Analog signal input (monitor)  21: PID feed forward</p>	0	-	-	page 6-81
E64	Operator Reference Frequency Saving Selection	<div style="display: flex; justify-content: space-between; border-bottom: 1px solid black; padding-bottom: 2px;"> <span>V/f</span> <span>DTV</span> <span>PG V/f</span> <span>PG DTV</span> </div> <div style="display: flex; justify-content: space-between; border-bottom: 1px solid black; padding-bottom: 2px;"> <span>SLV</span> <span>PGV</span> <span>PM SLV</span> <span>PM PGV</span> </div> <p>0: Automatic saving (when main power is turned OFF)  1: Saving by Up/Down key and ENTER key</p>	0	Available	-	page 5-27



Parameter No.	Function name	Monitor or Data Range	Default data	Setting during RUN	Unit	Page
E65	Reference Loss Detection Operation Selection	<div style="display: flex; justify-content: space-between; border-bottom: 1px solid black; padding-bottom: 2px;"> <span>V/f</span> <span>DTV</span> <span>PG V/f</span> <span>PG DTV</span> </div> <div style="display: flex; justify-content: space-between; border-bottom: 1px solid black; padding-bottom: 2px;"> <span>SLV</span> <span>PGV</span> <span>PM SLV</span> <span>PM PGV</span> </div> 0: Decelerate to stop 20 to 120 %: Continuous operation frequency ratio 999: Disable	32767	Available	%	page 5-27
E76	Main Circuit DC Voltage Low-voltage Detection Level	<div style="display: flex; justify-content: space-between; border-bottom: 1px solid black; padding-bottom: 2px;"> <span>V/f</span> <span>DTV</span> <span>PG V/f</span> <span>PG DTV</span> </div> <div style="display: flex; justify-content: space-between; border-bottom: 1px solid black; padding-bottom: 2px;"> <span>SLV</span> <span>PGV</span> <span>PM SLV</span> <span>PM PGV</span> </div> 200 to 400V (200Vseries) 400 to 800V (400Vseries)	235	Available	V	page 7-106
E78	Overtorque/Undertorque Detection Level at Forward Power Running	<div style="display: flex; justify-content: space-between; border-bottom: 1px solid black; padding-bottom: 2px;"> <span>V/f</span> <span>DTV</span> <span>PG V/f</span> <span>PG DTV</span> </div> <div style="display: flex; justify-content: space-between; border-bottom: 1px solid black; padding-bottom: 2px;"> <span>SLV</span> <span>PGV</span> <span>PM SLV</span> <span>PM PGV</span> </div> 0 to 300 %	100	Available	%	page 6-85
E79	Torque detection 1 Detection Timer	<div style="display: flex; justify-content: space-between; border-bottom: 1px solid black; padding-bottom: 2px;"> <span>V/f</span> <span>DTV</span> <span>PG V/f</span> <span>PG DTV</span> </div> <div style="display: flex; justify-content: space-between; border-bottom: 1px solid black; padding-bottom: 2px;"> <span>SLV</span> <span>PGV</span> <span>PM SLV</span> <span>PM PGV</span> </div> 0.01 to 600.00 s	10	Available	s	page 6-85
E80	Overtorque/Undertorque Detection Level at Reverse Regeneration	<div style="display: flex; justify-content: space-between; border-bottom: 1px solid black; padding-bottom: 2px;"> <span>V/f</span> <span>DTV</span> <span>PG V/f</span> <span>PG DTV</span> </div> <div style="display: flex; justify-content: space-between; border-bottom: 1px solid black; padding-bottom: 2px;"> <span>SLV</span> <span>PGV</span> <span>PM SLV</span> <span>PM PGV</span> </div> 0 to 300 %	100	Available	%	page 6-85
E98	Input Terminal [DI6] Function Selection	<div style="display: flex; justify-content: space-between; border-bottom: 1px solid black; padding-bottom: 2px;"> <span>V/f</span> <span>DTV</span> <span>PG V/f</span> <span>PG DTV</span> </div> <div style="display: flex; justify-content: space-between; border-bottom: 1px solid black; padding-bottom: 2px;"> <span>SLV</span> <span>PGV</span> <span>PM SLV</span> <span>PM PGV</span> </div> 0 to 188 normally-open input, 1000 to 1188 normally-close input	98	-	-	page 7-26
E99	Input Terminal [DI7] Function Selection	<div style="display: flex; justify-content: space-between; border-bottom: 1px solid black; padding-bottom: 2px;"> <span>V/f</span> <span>DTV</span> <span>PG V/f</span> <span>PG DTV</span> </div> <div style="display: flex; justify-content: space-between; border-bottom: 1px solid black; padding-bottom: 2px;"> <span>SLV</span> <span>PGV</span> <span>PM SLV</span> <span>PM PGV</span> </div> 0 to 188 normally-open input, 1000 to 1188 normally-close input	99	-	-	page 7-26
E102	2nd RUN Command Selection	<div style="display: flex; justify-content: space-between; border-bottom: 1px solid black; padding-bottom: 2px;"> <span>V/f</span> <span>DTV</span> <span>PG V/f</span> <span>PG DTV</span> </div> <div style="display: flex; justify-content: space-between; border-bottom: 1px solid black; padding-bottom: 2px;"> <span>SLV</span> <span>PGV</span> <span>PM SLV</span> <span>PM PGV</span> </div> 0: Operator 1: Terminal command FW or RV 2: Operator (Forward direction) 3: Operator (Reverse direction) 4: RS-485 communication 5: Fieldbus (Reserved)	2	-	-	page 5-25

Parameter No.	Function name	Monitor or Data Range	Default data	Setting during RUN	Unit	Page
E103	Acceleration Stop Frequency	<div style="display: flex; justify-content: space-between; font-size: small;"> <span>V/f</span> <span>DTV</span> <span>PG V/f</span> <span>PG DTV</span> </div> <div style="display: flex; justify-content: space-between; font-size: small;"> <span>SLV</span> <span>PGV</span> <span>PM SLV</span> <span>PM PGV</span> </div> <p>0.00: Disable 0.01 to 590.00 Hz</p>	0.0	-	Hz	page 5-42
E104	Acceleration Stop Time	<div style="display: flex; justify-content: space-between; font-size: small;"> <span>V/f</span> <span>DTV</span> <span>PG V/f</span> <span>PG DTV</span> </div> <div style="display: flex; justify-content: space-between; font-size: small;"> <span>SLV</span> <span>PGV</span> <span>PM SLV</span> <span>PM PGV</span> </div> <p>0.0: Disable 0.1 to 60.0 s</p>	0.00	-	s	page 5-42
E105	Deceleration Stop Frequency	<div style="display: flex; justify-content: space-between; font-size: small;"> <span>V/f</span> <span>DTV</span> <span>PG V/f</span> <span>PG DTV</span> </div> <div style="display: flex; justify-content: space-between; font-size: small;"> <span>SLV</span> <span>PGV</span> <span>PM SLV</span> <span>PM PGV</span> </div> <p>0.00: Disable 0.01 to 590.00 Hz</p>	0.00	-	Hz	page 5-42
E106	Deceleration Stop Time	<div style="display: flex; justify-content: space-between; font-size: small;"> <span>V/f</span> <span>DTV</span> <span>PG V/f</span> <span>PG DTV</span> </div> <div style="display: flex; justify-content: space-between; font-size: small;"> <span>SLV</span> <span>PGV</span> <span>PM SLV</span> <span>PM PGV</span> </div> <p>0.0: Disable 0.1 to 60.0 s</p>	0.0	-	s	page 5-42
E107	Multi-step Frequency Selection	<div style="display: flex; justify-content: space-between; font-size: small;"> <span>V/f</span> <span>DTV</span> <span>PG V/f</span> <span>PG DTV</span> </div> <div style="display: flex; justify-content: space-between; font-size: small;"> <span>SLV</span> <span>PGV</span> <span>PM SLV</span> <span>PM PGV</span> </div> <p>0: Binary (CF1 to CF4) 1: Bit (SF1 to SF7)</p>	0	-	-	page 5-57
E109	2nd Frequency Reference/2nd Multi-step Frequency Reference 0	<div style="display: flex; justify-content: space-between; font-size: small;"> <span>V/f</span> <span>DTV</span> <span>PG V/f</span> <span>PG DTV</span> </div> <div style="display: flex; justify-content: space-between; font-size: small;"> <span>SLV</span> <span>PGV</span> <span>PM SLV</span> <span>PM PGV</span> </div> <p>0.0 to 590.00 Hz</p>	0.00	Available	Hz	page 5-27
E111	Jogging Operation Selection	<div style="display: flex; justify-content: space-between; font-size: small;"> <span>V/f</span> <span>DTV</span> <span>PG V/f</span> <span>PG DTV</span> </div> <div style="display: flex; justify-content: space-between; font-size: small;"> <span>SLV</span> <span>PGV</span> <span>PM SLV</span> <span>PM PGV</span> </div> <p>0: Free run stop on jogging stop, disabled in operation 1: Deceleration stop on jogging stop, disabled in operation 2: DC injection braking on jogging stop, disabled in operation 3: Free run stop on jogging stop, enabled in operation 4: Deceleration stop on jogging stop, enabled in operation 5: DC injection braking on jogging stop, enabled in operation</p>	4	-	-	page 5-60
E112	1st Torque Boost Function Selection	<div style="display: flex; justify-content: space-between; font-size: small;"> <span>V/f</span> <span>DTV</span> <span>PG V/f</span> <span>PG DTV</span> </div> <div style="display: flex; justify-content: space-between; font-size: small;"> <span>SLV</span> <span>PGV</span> <span>PM SLV</span> <span>PM PGV</span> </div> <p>0: Manual torque boost 1: Automatic torque boost</p>	1	-	-	page 5-73

Parameter No.	Function name	Monitor or Data Range	Default data	Setting during RUN	Unit	Page
E113	2nd Torque Boost Function Selection	<div style="display: flex; justify-content: space-between; border-bottom: 1px solid black; padding-bottom: 2px;"> <span>V/f</span> <span>DTV</span> <span>PG V/f</span> <span>PG DTV</span> </div> <div style="display: flex; justify-content: space-between; border-bottom: 1px solid black; padding-bottom: 2px;"> <span>SLV</span> <span>PGV</span> <span>PM SLV</span> <span>PM PGV</span> </div> 0: Manual torque boost 1: Automatic torque boost	1	-	-	page 5-73
E114	DC Injection Braking Selection	<div style="display: flex; justify-content: space-between; border-bottom: 1px solid black; padding-bottom: 2px;"> <span>V/f</span> <span>DTV</span> <span>PG V/f</span> <span>PG DTV</span> </div> <div style="display: flex; justify-content: space-between; border-bottom: 1px solid black; padding-bottom: 2px;"> <span>SLV</span> <span>PGV</span> <span>PM SLV</span> <span>PM PGV</span> </div> 0: External DC injection braking 1: External DC injection braking/setting frequency 2: Setting frequency	0	-	-	page 7-63
E115	External DC Injection Braking Edge/Level Selection	<div style="display: flex; justify-content: space-between; border-bottom: 1px solid black; padding-bottom: 2px;"> <span>V/f</span> <span>DTV</span> <span>PG V/f</span> <span>PG DTV</span> </div> <div style="display: flex; justify-content: space-between; border-bottom: 1px solid black; padding-bottom: 2px;"> <span>SLV</span> <span>PGV</span> <span>PM SLV</span> <span>PM PGV</span> </div> 0: Edge operation 1: Level operation	1	-	-	page 7-63
E117	2nd Frequency Upper Limit	<div style="display: flex; justify-content: space-between; border-bottom: 1px solid black; padding-bottom: 2px;"> <span>V/f</span> <span>DTV</span> <span>PG V/f</span> <span>PG DTV</span> </div> <div style="display: flex; justify-content: space-between; border-bottom: 1px solid black; padding-bottom: 2px;"> <span>SLV</span> <span>PGV</span> <span>PM SLV</span> <span>PM PGV</span> </div> 0.00 to 590.00 Hz Internal resolution is 0.1 steps.	70.00	-	Hz	page 5-32
E118	2nd Frequency Lower Limit	<div style="display: flex; justify-content: space-between; border-bottom: 1px solid black; padding-bottom: 2px;"> <span>V/f</span> <span>DTV</span> <span>PG V/f</span> <span>PG DTV</span> </div> <div style="display: flex; justify-content: space-between; border-bottom: 1px solid black; padding-bottom: 2px;"> <span>SLV</span> <span>PGV</span> <span>PM SLV</span> <span>PM PGV</span> </div> 0.00 to 590.00 Hz Internal resolution is 0.1 steps.	0.00	-	Hz	page 5-32
E119	PID Control Feedback Selection	<div style="display: flex; justify-content: space-between; border-bottom: 1px solid black; padding-bottom: 2px;"> <span>V/f</span> <span>DTV</span> <span>PG V/f</span> <span>PG DTV</span> </div> <div style="display: flex; justify-content: space-between; border-bottom: 1px solid black; padding-bottom: 2px;"> <span>SLV</span> <span>PGV</span> <span>PM SLV</span> <span>PM PGV</span> </div> 0: Analog input 2: RS-485 communications 3: Pulse train input	0	-	-	page 7-123
E120	PID Control PID Output Variable Range for Process Control	<div style="display: flex; justify-content: space-between; border-bottom: 1px solid black; padding-bottom: 2px;"> <span>V/f</span> <span>DTV</span> <span>PG V/f</span> <span>PG DTV</span> </div> <div style="display: flex; justify-content: space-between; border-bottom: 1px solid black; padding-bottom: 2px;"> <span>SLV</span> <span>PGV</span> <span>PM SLV</span> <span>PM PGV</span> </div> 0.0: Disable 0.1 to 100.0	0.0	-	%	page 7-123
E121	PID Control PID Feed-forward Selection for Process Control	<div style="display: flex; justify-content: space-between; border-bottom: 1px solid black; padding-bottom: 2px;"> <span>V/f</span> <span>DTV</span> <span>PG V/f</span> <span>PG DTV</span> </div> <div style="display: flex; justify-content: space-between; border-bottom: 1px solid black; padding-bottom: 2px;"> <span>SLV</span> <span>PGV</span> <span>PM SLV</span> <span>PM PGV</span> </div> 0: Disable 1: Input terminal (AI1, AI2)	0	-	-	page 7-123
E122	1st AVR Function Selection	<div style="display: flex; justify-content: space-between; border-bottom: 1px solid black; padding-bottom: 2px;"> <span>V/f</span> <span>DTV</span> <span>PG V/f</span> <span>PG DTV</span> </div> <div style="display: flex; justify-content: space-between; border-bottom: 1px solid black; padding-bottom: 2px;"> <span>SLV</span> <span>PGV</span> <span>PM SLV</span> <span>PM PGV</span> </div> 0: Disable 1: Enable	1	-	-	page 7-121

Parameter No.	Function name	Monitor or Data Range	Default data	Setting during RUN	Unit	Page
E123	2nd AVR Function Selection	<input type="checkbox"/> V/f <input type="checkbox"/> DTV <input type="checkbox"/> PG V/f <input type="checkbox"/> PG DTV <input type="checkbox"/> SLV <input type="checkbox"/> PGV <input type="checkbox"/> PM SLV <input type="checkbox"/> PM PGV 0: Disable 1: Enable	1	-	-	page 7-121
E124	Energy-saving Operation Function Selection	<input type="checkbox"/> V/f <input type="checkbox"/> DTV <input type="checkbox"/> PG V/f <input type="checkbox"/> PG DTV <input type="checkbox"/> SLV <input type="checkbox"/> PGV <input type="checkbox"/> PM SLV <input type="checkbox"/> PM PGV 0: Normal operation 1: Energy-saving operation	0	-	-	page 7-141
E125	1st 2-step Acceleration/ Deceleration switching Condition Selection	<input type="checkbox"/> V/f <input type="checkbox"/> DTV <input type="checkbox"/> PG V/f <input type="checkbox"/> PG DTV <input type="checkbox"/> SLV <input type="checkbox"/> PGV <input type="checkbox"/> PM SLV <input type="checkbox"/> PM PGV 0: Switching by 2CH terminal 1: Switching by setting 2: Forward and reverse 3: Switching by RT1, RT2 terminals	0	-	-	page 5-43
E126	2nd 2-step Acceleration/Deceleration Switching Condition Selection	<input type="checkbox"/> V/f <input type="checkbox"/> DTV <input type="checkbox"/> PG V/f <input type="checkbox"/> PG DTV <input type="checkbox"/> SLV <input type="checkbox"/> PGV <input type="checkbox"/> PM SLV <input type="checkbox"/> PM PGV 0: Switching by 2CH terminal 1: Switching by setting 2: Forward and reverse 3: Switching by RT1, RT2 terminals	0	-	-	page 5-43
E127	1st 2-step Acceleration Switching Frequency	<input type="checkbox"/> V/f <input type="checkbox"/> DTV <input type="checkbox"/> PG V/f <input type="checkbox"/> PG DTV <input type="checkbox"/> SLV <input type="checkbox"/> PGV <input type="checkbox"/> PM SLV <input type="checkbox"/> PM PGV 0.00 to 590.00 Hz	0.00	-	Hz	page 5-43
E128	2nd 2-step Acceleration Switching Frequency	<input type="checkbox"/> V/f <input type="checkbox"/> DTV <input type="checkbox"/> PG V/f <input type="checkbox"/> PG DTV <input type="checkbox"/> SLV <input type="checkbox"/> PGV <input type="checkbox"/> PM SLV <input type="checkbox"/> PM PGV 0.00 to 590.00 Hz	0.00	-	Hz	page 5-43
E129	1st 2-step Deceleration Switching Frequency	<input type="checkbox"/> V/f <input type="checkbox"/> DTV <input type="checkbox"/> PG V/f <input type="checkbox"/> PG DTV <input type="checkbox"/> SLV <input type="checkbox"/> PGV <input type="checkbox"/> PM SLV <input type="checkbox"/> PM PGV 0.00 to 590.00 Hz	0.00	-	Hz	page 5-43
E130	2nd 2-step Deceleration Frequency	<input type="checkbox"/> V/f <input type="checkbox"/> DTV <input type="checkbox"/> PG V/f <input type="checkbox"/> PG DTV <input type="checkbox"/> SLV <input type="checkbox"/> PGV <input type="checkbox"/> PM SLV <input type="checkbox"/> PM PGV 0.00 to 590.00 Hz	0.00	-	Hz	page 5-43

Parameter No.	Function name	Monitor or Data Range	Default data	Setting during RUN	Unit	Page
E131	Frequency Calculation Operation Target 1	<div style="display: flex; justify-content: space-between; border-bottom: 1px solid black; margin-bottom: 5px;"> <span>V/f</span> <span>DTV</span> <span>PG V/f</span> <span>PG DTV</span> </div> <div style="display: flex; justify-content: space-between; border-bottom: 1px solid black; margin-bottom: 5px;"> <span>SLV</span> <span>PGV</span> <span>PM SLV</span> <span>PM PGV</span> </div> 0: Up/Down keys on Operator 1: Voltage input to terminal [AI1] 2: Current input to terminal [AI2](AI1) 3: Voltage input to terminal [AI2](AIV) 5: Pulse train input 6: RS-485 communication 7: Fieldbus (Reserved)	1	-	-	page 7-118
E132	Frequency Calculation Operation Target 2	<div style="display: flex; justify-content: space-between; border-bottom: 1px solid black; margin-bottom: 5px;"> <span>V/f</span> <span>DTV</span> <span>PG V/f</span> <span>PG DTV</span> </div> <div style="display: flex; justify-content: space-between; border-bottom: 1px solid black; margin-bottom: 5px;"> <span>SLV</span> <span>PGV</span> <span>PM SLV</span> <span>PM PGV</span> </div> 0: Up/Down keys on Operator 1: Voltage input to terminal [AI1] 2: Current input to terminal [AI2](AI1) 3: Voltage input to terminal [AI2](AIV) 5: Pulse train input 6: RS-485 communication 7: Fieldbus (Reserved)	2	-	-	page 7-118
E133	Frequency Calculation Operator Selection	<div style="display: flex; justify-content: space-between; border-bottom: 1px solid black; margin-bottom: 5px;"> <span>V/f</span> <span>DTV</span> <span>PG V/f</span> <span>PG DTV</span> </div> <div style="display: flex; justify-content: space-between; border-bottom: 1px solid black; margin-bottom: 5px;"> <span>SLV</span> <span>PGV</span> <span>PM SLV</span> <span>PM PGV</span> </div> 0: Addition (E131 + E132) 1: Subtraction (E131 - E132) 2: Multiplication (E131 x E132)	0	-	-	page 7-118
E134	Frequency Addition Amount	<div style="display: flex; justify-content: space-between; border-bottom: 1px solid black; margin-bottom: 5px;"> <span>V/f</span> <span>DTV</span> <span>PG V/f</span> <span>PG DTV</span> </div> <div style="display: flex; justify-content: space-between; border-bottom: 1px solid black; margin-bottom: 5px;"> <span>SLV</span> <span>PGV</span> <span>PM SLV</span> <span>PM PGV</span> </div> 0.00 to 590.00 Hz	0.00	-	Hz	page 7-118
E135	Frequency Addition Sign Selection	<div style="display: flex; justify-content: space-between; border-bottom: 1px solid black; margin-bottom: 5px;"> <span>V/f</span> <span>DTV</span> <span>PG V/f</span> <span>PG DTV</span> </div> <div style="display: flex; justify-content: space-between; border-bottom: 1px solid black; margin-bottom: 5px;"> <span>SLV</span> <span>PGV</span> <span>PM SLV</span> <span>PM PGV</span> </div> 0: Frequency command + E134 1: Frequency command - E134	0	-	-	page 7-118
E139	Overvoltage/Overcurrent Restart Function Selection	<div style="display: flex; justify-content: space-between; border-bottom: 1px solid black; margin-bottom: 5px;"> <span>V/f</span> <span>DTV</span> <span>PG V/f</span> <span>PG DTV</span> </div> <div style="display: flex; justify-content: space-between; border-bottom: 1px solid black; margin-bottom: 5px;"> <span>SLV</span> <span>PGV</span> <span>PM SLV</span> <span>PM PGV</span> </div> 0: Trip immediately 4: Restart at the frequency selected by E152	0	-	-	page 7-58

Parameter No.	Function name	Monitor or Data Range	Default data	Setting during RUN	Unit	Page
E146	2nd Overload Protect Function Selection	<div style="display: flex; justify-content: space-between; margin-bottom: 5px;"> <span>V/f</span> <span>DTV</span> <span>PG V/f</span> <span>PG DTV</span> </div> <div style="display: flex; justify-content: space-between; margin-bottom: 5px;"> <span>SLV</span> <span>PGV</span> <span>PM SLV</span> <span>PM PGV</span> </div> 0: Disable 1: Enable at constant speed 2: Enable during ACC/ constant speed operation	2	Available	-	page 7-82
E147	2nd Overload Protect Level	<div style="display: flex; justify-content: space-between; margin-bottom: 5px;"> <span>V/f</span> <span>DTV</span> <span>PG V/f</span> <span>PG DTV</span> </div> <div style="display: flex; justify-content: space-between; margin-bottom: 5px;"> <span>SLV</span> <span>PGV</span> <span>PM SLV</span> <span>PM PGV</span> </div> 20 to 200 % The data is interpreted as the rated output current of the inverter for 100%.	180	Available	%	page 7-82
E152	Starting Frequency Selection at Frequency Pull-in Restart	<div style="display: flex; justify-content: space-between; margin-bottom: 5px;"> <span>V/f</span> <span>DTV</span> <span>PG V/f</span> <span>PG DTV</span> </div> <div style="display: flex; justify-content: space-between; margin-bottom: 5px;"> <span>SLV</span> <span>PGV</span> <span>PM SLV</span> <span>PM PGV</span> </div> 0: Frequency at which the power failure occurred 1: Maximum output frequency 2: Reference frequency 3: Starting frequency	3	-	-	page 7-49
E154	RUN Time Over (RNT)/Power ON Time Over (ONT) Detection Level	<div style="display: flex; justify-content: space-between; margin-bottom: 5px;"> <span>V/f</span> <span>DTV</span> <span>PG V/f</span> <span>PG DTV</span> </div> <div style="display: flex; justify-content: space-between; margin-bottom: 5px;"> <span>SLV</span> <span>PGV</span> <span>PM SLV</span> <span>PM PGV</span> </div> 0 to 9999	0	-	10 hex	page 7-92
E157	Analog Input [AI1] Detection Upper Limit Level	<div style="display: flex; justify-content: space-between; margin-bottom: 5px;"> <span>V/f</span> <span>DTV</span> <span>PG V/f</span> <span>PG DTV</span> </div> <div style="display: flex; justify-content: space-between; margin-bottom: 5px;"> <span>SLV</span> <span>PGV</span> <span>PM SLV</span> <span>PM PGV</span> </div> 0 to 100 %	100	Available	%	page 7-103
E158	Analog Input [AI1] Detection Lower Limit Level	<div style="display: flex; justify-content: space-between; margin-bottom: 5px;"> <span>V/f</span> <span>DTV</span> <span>PG V/f</span> <span>PG DTV</span> </div> <div style="display: flex; justify-content: space-between; margin-bottom: 5px;"> <span>SLV</span> <span>PGV</span> <span>PM SLV</span> <span>PM PGV</span> </div> 0 to 100 %	0	Available	%	page 7-103
E159	Analog Input [AI1] Level Detection Hysteresis Width	<div style="display: flex; justify-content: space-between; margin-bottom: 5px;"> <span>V/f</span> <span>DTV</span> <span>PG V/f</span> <span>PG DTV</span> </div> <div style="display: flex; justify-content: space-between; margin-bottom: 5px;"> <span>SLV</span> <span>PGV</span> <span>PM SLV</span> <span>PM PGV</span> </div> 0 to 10 %	0	Available	%	page 7-103
E160	Analog Input [AI2] Detection Upper Limit Level	<div style="display: flex; justify-content: space-between; margin-bottom: 5px;"> <span>V/f</span> <span>DTV</span> <span>PG V/f</span> <span>PG DTV</span> </div> <div style="display: flex; justify-content: space-between; margin-bottom: 5px;"> <span>SLV</span> <span>PGV</span> <span>PM SLV</span> <span>PM PGV</span> </div> 0 to 100 %	100	Available	%	page 7-103
E161	Analog Input [AI2] Detection Lower Limit Level	<div style="display: flex; justify-content: space-between; margin-bottom: 5px;"> <span>V/f</span> <span>DTV</span> <span>PG V/f</span> <span>PG DTV</span> </div> <div style="display: flex; justify-content: space-between; margin-bottom: 5px;"> <span>SLV</span> <span>PGV</span> <span>PM SLV</span> <span>PM PGV</span> </div> 0 to 100 %	0	Available	%	page 7-103
E162	Analog Input [AI2] Level Detection Hysteresis Width	<div style="display: flex; justify-content: space-between; margin-bottom: 5px;"> <span>V/f</span> <span>DTV</span> <span>PG V/f</span> <span>PG DTV</span> </div> <div style="display: flex; justify-content: space-between; margin-bottom: 5px;"> <span>SLV</span> <span>PGV</span> <span>PM SLV</span> <span>PM PGV</span> </div> 0 to 10 %	0	Available	%	page 7-103

Parameter No.	Function name	Monitor or Data Range	Default data	Setting during RUN	Unit	Page
E163	Analog Operation Level at [AI1] Disconnection	<div style="display: flex; justify-content: space-between; border-bottom: 1px solid black; padding-bottom: 2px;"> <span>V/f</span> <span>DTV</span> <span>PG V/f</span> <span>PG DTV</span> </div> <div style="display: flex; justify-content: space-between; border-bottom: 1px solid black; padding-bottom: 2px;"> <span>SLV</span> <span>PGV</span> <span>PM SLV</span> <span>PM PGV</span> </div> -100 to 100 % 999: Disable	32767	-	%	page 7-103
E164	Analog Operation Level at [AI2] Disconnection	<div style="display: flex; justify-content: space-between; border-bottom: 1px solid black; padding-bottom: 2px;"> <span>V/f</span> <span>DTV</span> <span>PG V/f</span> <span>PG DTV</span> </div> <div style="display: flex; justify-content: space-between; border-bottom: 1px solid black; padding-bottom: 2px;"> <span>SLV</span> <span>PGV</span> <span>PM SLV</span> <span>PM PGV</span> </div> 0 to 100 % 999: Disable	32767	-	%	page 7-103
E165	Carrier Frequency Automatic Reduction Function Selection	<div style="display: flex; justify-content: space-between; border-bottom: 1px solid black; padding-bottom: 2px;"> <span>V/f</span> <span>DTV</span> <span>PG V/f</span> <span>PG DTV</span> </div> <div style="display: flex; justify-content: space-between; border-bottom: 1px solid black; padding-bottom: 2px;"> <span>SLV</span> <span>PGV</span> <span>PM SLV</span> <span>PM PGV</span> </div> 0: Disable 1: Enable	1	-	-	page 7-114
E166	Non-linear V/f Frequency 1	<div style="display: flex; justify-content: space-between; border-bottom: 1px solid black; padding-bottom: 2px;"> <span>V/f</span> <span>DTV</span> <span>PG V/f</span> <span>PG DTV</span> </div> <div style="display: flex; justify-content: space-between; border-bottom: 1px solid black; padding-bottom: 2px;"> <span>SLV</span> <span>PGV</span> <span>PM SLV</span> <span>PM PGV</span> </div> 0.0: Disable 0.1 to 590.0 Hz	0.0	-	Hz	page 5-10
E167	Non-linear V/f Voltage 1	<div style="display: flex; justify-content: space-between; border-bottom: 1px solid black; padding-bottom: 2px;"> <span>V/f</span> <span>DTV</span> <span>PG V/f</span> <span>PG DTV</span> </div> <div style="display: flex; justify-content: space-between; border-bottom: 1px solid black; padding-bottom: 2px;"> <span>SLV</span> <span>PGV</span> <span>PM SLV</span> <span>PM PGV</span> </div> 0 to 240 V (for 200 V class series) 0 to 500 V (for 400 V class series)	0	-	V	page 5-10
E168	Non-linear V/f Frequency 2	<div style="display: flex; justify-content: space-between; border-bottom: 1px solid black; padding-bottom: 2px;"> <span>V/f</span> <span>DTV</span> <span>PG V/f</span> <span>PG DTV</span> </div> <div style="display: flex; justify-content: space-between; border-bottom: 1px solid black; padding-bottom: 2px;"> <span>SLV</span> <span>PGV</span> <span>PM SLV</span> <span>PM PGV</span> </div> 0.0: Disable 0.1 to 590.0 Hz	0.0	-	Hz	page 5-10
E169	Non-linear V/f Voltage 2	<div style="display: flex; justify-content: space-between; border-bottom: 1px solid black; padding-bottom: 2px;"> <span>V/f</span> <span>DTV</span> <span>PG V/f</span> <span>PG DTV</span> </div> <div style="display: flex; justify-content: space-between; border-bottom: 1px solid black; padding-bottom: 2px;"> <span>SLV</span> <span>PGV</span> <span>PM SLV</span> <span>PM PGV</span> </div> 0 to 240 V (for 200 V class series) 0 to 500 V (for 400 V class series)	0	-	V	page 5-10
E170	Non-linear V/f Frequency 3	<div style="display: flex; justify-content: space-between; border-bottom: 1px solid black; padding-bottom: 2px;"> <span>V/f</span> <span>DTV</span> <span>PG V/f</span> <span>PG DTV</span> </div> <div style="display: flex; justify-content: space-between; border-bottom: 1px solid black; padding-bottom: 2px;"> <span>SLV</span> <span>PGV</span> <span>PM SLV</span> <span>PM PGV</span> </div> 0.0: Disable 0.1 to 590.0 Hz	0.0	-	Hz	page 5-10
E171	Non-linear V/f Voltage 3	<div style="display: flex; justify-content: space-between; border-bottom: 1px solid black; padding-bottom: 2px;"> <span>V/f</span> <span>DTV</span> <span>PG V/f</span> <span>PG DTV</span> </div> <div style="display: flex; justify-content: space-between; border-bottom: 1px solid black; padding-bottom: 2px;"> <span>SLV</span> <span>PGV</span> <span>PM SLV</span> <span>PM PGV</span> </div> 0 to 240 V (for 200 V class series) 0 to 500 V (for 400 V class series)	0	-	V	page 5-10

Parameter No.	Function name	Monitor or Data Range	Default data	Setting during RUN	Unit	Page
E172	Non-linear V/f Frequency 4	<input type="checkbox"/> V/f <input type="checkbox"/> DTV <input type="checkbox"/> PG V/f <input type="checkbox"/> PG DTV <input type="checkbox"/> SLV <input type="checkbox"/> PGV <input type="checkbox"/> PM SLV <input type="checkbox"/> PM PGV 0.0: Disable 0.1 to 590.0 Hz	0.0	-	Hz	page 5-10
E173	Non-linear V/f Voltage 4	<input type="checkbox"/> V/f <input type="checkbox"/> DTV <input type="checkbox"/> PG V/f <input type="checkbox"/> PG DTV <input type="checkbox"/> SLV <input type="checkbox"/> PGV <input type="checkbox"/> PM SLV <input type="checkbox"/> PM PGV 0 to 240 V (for 200 V class series) 0 to 500 V (for 400 V class series)	0	-	V	page 5-10
E174	Non-linear V/f Frequency 5	<input type="checkbox"/> V/f <input type="checkbox"/> DTV <input type="checkbox"/> PG V/f <input type="checkbox"/> PG DTV <input type="checkbox"/> SLV <input type="checkbox"/> PGV <input type="checkbox"/> PM SLV <input type="checkbox"/> PM PGV 0.0: Disable 0.1 to 590.0 Hz	0.0	-	Hz	page 5-10
E175	Non-linear V/f Voltage 5	<input type="checkbox"/> V/f <input type="checkbox"/> DTV <input type="checkbox"/> PG V/f <input type="checkbox"/> PG DTV <input type="checkbox"/> SLV <input type="checkbox"/> PGV <input type="checkbox"/> PM SLV <input type="checkbox"/> PM PGV 0 to 240 V (for 200 V class series) 0 to 500 V (for 400 V class series)	0	-	V	page 5-10
E176	Non-linear V/f Frequency 6	<input type="checkbox"/> V/f <input type="checkbox"/> DTV <input type="checkbox"/> PG V/f <input type="checkbox"/> PG DTV <input type="checkbox"/> SLV <input type="checkbox"/> PGV <input type="checkbox"/> PM SLV <input type="checkbox"/> PM PGV 0.0: Disable 0.1 to 590.0 Hz	0.0	-	Hz	page 5-10
E177	Non-linear V/f Voltage 6	<input type="checkbox"/> V/f <input type="checkbox"/> DTV <input type="checkbox"/> PG V/f <input type="checkbox"/> PG DTV <input type="checkbox"/> SLV <input type="checkbox"/> PGV <input type="checkbox"/> PM SLV <input type="checkbox"/> PM PGV 0 to 240 V (for 200 V class series) 0 to 500 V (for 400 V class series)	0	-	V	page 5-10
E178	Non-linear V/f Frequency 7	<input type="checkbox"/> V/f <input type="checkbox"/> DTV <input type="checkbox"/> PG V/f <input type="checkbox"/> PG DTV <input type="checkbox"/> SLV <input type="checkbox"/> PGV <input type="checkbox"/> PM SLV <input type="checkbox"/> PM PGV 0.0: Disable 0.1 to 590.0 Hz	0.0	-	Hz	page 5-10
E179	Non-linear V/f Voltage 7	<input type="checkbox"/> V/f <input type="checkbox"/> DTV <input type="checkbox"/> PG V/f <input type="checkbox"/> PG DTV <input type="checkbox"/> SLV <input type="checkbox"/> PGV <input type="checkbox"/> PM SLV <input type="checkbox"/> PM PGV 0 to 240 V (for 200 V class series) 0 to 500 V (for 400 V class series)	0	-	V	page 5-10



Parameter No.	Function name	Monitor or Data Range	Default data	Setting during RUN	Unit	Page
E181	Acceleration Wait Time on Brake Control	<div style="display: flex; justify-content: space-between; border-bottom: 1px solid black; padding-bottom: 2px;"> <span>V/f</span> <span>DTV</span> <span>PG V/f</span> <span>PG DTV</span> </div> <div style="display: flex; justify-content: space-between; border-bottom: 1px solid black; padding-bottom: 2px;"> <span>SLV</span> <span>PGV</span> <span>PM SLV</span> <span>PM PGV</span> </div> 0.000 to 5.000 s	0.000	-	s	page 6-76
E184	Low Current Detection Condition Selection (LOC)	<div style="display: flex; justify-content: space-between; border-bottom: 1px solid black; padding-bottom: 2px;"> <span>V/f</span> <span>DTV</span> <span>PG V/f</span> <span>PG DTV</span> </div> <div style="display: flex; justify-content: space-between; border-bottom: 1px solid black; padding-bottom: 2px;"> <span>SLV</span> <span>PGV</span> <span>PM SLV</span> <span>PM PGV</span> </div> 0: Output during acceleration/ deceleration and constant-speed operation 1: Output only during constant-speed operation	1	-	-	page 7-102
E185	Overload Warning Detection Condition Selection (OL1, OL2)	<div style="display: flex; justify-content: space-between; border-bottom: 1px solid black; padding-bottom: 2px;"> <span>V/f</span> <span>DTV</span> <span>PG V/f</span> <span>PG DTV</span> </div> <div style="display: flex; justify-content: space-between; border-bottom: 1px solid black; padding-bottom: 2px;"> <span>SLV</span> <span>PGV</span> <span>PM SLV</span> <span>PM PGV</span> </div> 0: Output during acceleration/ deceleration and constant-speed operation 1: Output only during constant-speed operation	1	-	-	page 7-82
E196	Overtorque/Undertorque Detection Level Reverse Power Running	<div style="display: flex; justify-content: space-between; border-bottom: 1px solid black; padding-bottom: 2px;"> <span>V/f</span> <span>DTV</span> <span>PG V/f</span> <span>PG DTV</span> </div> <div style="display: flex; justify-content: space-between; border-bottom: 1px solid black; padding-bottom: 2px;"> <span>SLV</span> <span>PGV</span> <span>PM SLV</span> <span>PM PGV</span> </div> 0 to 300 %	100	-	%	page 6-85
E197	Overtorque/Undertorque Detection Level Forward Regeneration	<div style="display: flex; justify-content: space-between; border-bottom: 1px solid black; padding-bottom: 2px;"> <span>V/f</span> <span>DTV</span> <span>PG V/f</span> <span>PG DTV</span> </div> <div style="display: flex; justify-content: space-between; border-bottom: 1px solid black; padding-bottom: 2px;"> <span>SLV</span> <span>PGV</span> <span>PM SLV</span> <span>PM PGV</span> </div> 0 to 300 %	100	-	%	page 6-85
E198	Overtorque/Undertorque Detection Condition Selection	<div style="display: flex; justify-content: space-between; border-bottom: 1px solid black; padding-bottom: 2px;"> <span>V/f</span> <span>DTV</span> <span>PG V/f</span> <span>PG DTV</span> </div> <div style="display: flex; justify-content: space-between; border-bottom: 1px solid black; padding-bottom: 2px;"> <span>SLV</span> <span>PGV</span> <span>PM SLV</span> <span>PM PGV</span> </div> 0: Output during acceleration/ deceleration and constant-speed operation 1: Output only during constant-speed operation	0	-	-	page 6-85
E199	0Hz Detection Output Detection Level (ZS)	<div style="display: flex; justify-content: space-between; border-bottom: 1px solid black; padding-bottom: 2px;"> <span>V/f</span> <span>DTV</span> <span>PG V/f</span> <span>PG DTV</span> </div> <div style="display: flex; justify-content: space-between; border-bottom: 1px solid black; padding-bottom: 2px;"> <span>SLV</span> <span>PGV</span> <span>PM SLV</span> <span>PM PGV</span> </div> 0.00 to 100.00 Hz	0	-	Hz	page 5-71

### 4-2-3 Parameter C (Frequency Reference and Analog Input Functions)

Parameter No.	Function name	Monitor or Data Range	Default data	Setting during RUN	Unit	Page
C01	Jump Frequency 1	<div style="display: flex; justify-content: space-between; border-bottom: 1px solid black; padding-bottom: 2px;"> <span>V/f</span> <span>DTV</span> <span>PG V/f</span> <span>PG DTV</span> </div> <div style="display: flex; justify-content: space-between; border-bottom: 1px solid black; padding-bottom: 2px;"> <span>SLV</span> <span>PGV</span> <span>PM SLV</span> <span>PM PGV</span> </div> 0.0 to 590.0 Hz	0.0	Available	Hz	page 7-116

Parameter No.	Function name	Monitor or Data Range	Default data	Setting during RUN	Unit	Page
C02	Jump Frequency 2	<input type="checkbox"/> V/f <input type="checkbox"/> DTV <input type="checkbox"/> PG V/f <input type="checkbox"/> PG DTV <input type="checkbox"/> SLV <input type="checkbox"/> PGV <input type="checkbox"/> PM SLV <input type="checkbox"/> PM PGV 0.0 to 590.0 Hz	0.0	Available	Hz	page 7-116
C03	Jump Frequency 3	<input type="checkbox"/> V/f <input type="checkbox"/> DTV <input type="checkbox"/> PG V/f <input type="checkbox"/> PG DTV <input type="checkbox"/> SLV <input type="checkbox"/> PGV <input type="checkbox"/> PM SLV <input type="checkbox"/> PM PGV 0.0 to 590.0 Hz	0.0	Available	Hz	page 7-116
C04	Jump Frequency Skip Width	<input type="checkbox"/> V/f <input type="checkbox"/> DTV <input type="checkbox"/> PG V/f <input type="checkbox"/> PG DTV <input type="checkbox"/> SLV <input type="checkbox"/> PGV <input type="checkbox"/> PM SLV <input type="checkbox"/> PM PGV 0.0 to 30.0 Hz	3.0	Available	Hz	page 7-116
C05	Multi-step Frequency Reference 1	<input type="checkbox"/> V/f <input type="checkbox"/> DTV <input type="checkbox"/> PG V/f <input type="checkbox"/> PG DTV <input type="checkbox"/> SLV <input type="checkbox"/> PGV <input type="checkbox"/> PM SLV <input type="checkbox"/> PM PGV 0.00 to 590.00 Hz	0.00	Available	Hz	page 5-57
C06	Multi-step Frequency Reference 2	<input type="checkbox"/> V/f <input type="checkbox"/> DTV <input type="checkbox"/> PG V/f <input type="checkbox"/> PG DTV <input type="checkbox"/> SLV <input type="checkbox"/> PGV <input type="checkbox"/> PM SLV <input type="checkbox"/> PM PGV 0.00 to 590.00 Hz	0.00	Available	Hz	page 5-57
C07	Multi-step Frequency Reference 3	<input type="checkbox"/> V/f <input type="checkbox"/> DTV <input type="checkbox"/> PG V/f <input type="checkbox"/> PG DTV <input type="checkbox"/> SLV <input type="checkbox"/> PGV <input type="checkbox"/> PM SLV <input type="checkbox"/> PM PGV 0.00 to 590.00 Hz	0.00	Available	Hz	page 5-57
C08	Multi-step Frequency Reference 4	<input type="checkbox"/> V/f <input type="checkbox"/> DTV <input type="checkbox"/> PG V/f <input type="checkbox"/> PG DTV <input type="checkbox"/> SLV <input type="checkbox"/> PGV <input type="checkbox"/> PM SLV <input type="checkbox"/> PM PGV 0.00 to 590.00 Hz	0.00	Available	Hz	page 5-57
C09	Multi-step Frequency Reference 5	<input type="checkbox"/> V/f <input type="checkbox"/> DTV <input type="checkbox"/> PG V/f <input type="checkbox"/> PG DTV <input type="checkbox"/> SLV <input type="checkbox"/> PGV <input type="checkbox"/> PM SLV <input type="checkbox"/> PM PGV 0.00 to 590.00 Hz	0.00	Available	Hz	page 5-57
C10	Multi-step Frequency Reference 6	<input type="checkbox"/> V/f <input type="checkbox"/> DTV <input type="checkbox"/> PG V/f <input type="checkbox"/> PG DTV <input type="checkbox"/> SLV <input type="checkbox"/> PGV <input type="checkbox"/> PM SLV <input type="checkbox"/> PM PGV 0.00 to 590.00 Hz	0.00	Available	Hz	page 5-57
C11	Multi-step Frequency Reference 7	<input type="checkbox"/> V/f <input type="checkbox"/> DTV <input type="checkbox"/> PG V/f <input type="checkbox"/> PG DTV <input type="checkbox"/> SLV <input type="checkbox"/> PGV <input type="checkbox"/> PM SLV <input type="checkbox"/> PM PGV 0.00 to 590.00 Hz	0.00	Available	Hz	page 5-57
C12	Multi-step Frequency Reference 8	<input type="checkbox"/> V/f <input type="checkbox"/> DTV <input type="checkbox"/> PG V/f <input type="checkbox"/> PG DTV <input type="checkbox"/> SLV <input type="checkbox"/> PGV <input type="checkbox"/> PM SLV <input type="checkbox"/> PM PGV 0.00 to 590.00 Hz	0.00	Available	Hz	page 5-57
C13	Multi-step Frequency Reference 9	<input type="checkbox"/> V/f <input type="checkbox"/> DTV <input type="checkbox"/> PG V/f <input type="checkbox"/> PG DTV <input type="checkbox"/> SLV <input type="checkbox"/> PGV <input type="checkbox"/> PM SLV <input type="checkbox"/> PM PGV 0.00 to 590.00 Hz	0.00	Available	Hz	page 5-57

Parameter No.	Function name	Monitor or Data Range	Default data	Setting during RUN	Unit	Page
C14	Multi-step Frequency Reference 10	<div style="display: flex; justify-content: space-between; border-bottom: 1px solid black; padding-bottom: 2px;"> <span>V/f</span> <span>DTV</span> <span>PG V/f</span> <span>PG DTV</span> </div> <div style="display: flex; justify-content: space-between; border-bottom: 1px solid black; padding-bottom: 2px;"> <span>SLV</span> <span>PGV</span> <span>PM SLV</span> <span>PM PGV</span> </div> 0.00 to 590.00 Hz	0.00	Available	Hz	page 5-57
C15	Multi-step Frequency Reference 11	<div style="display: flex; justify-content: space-between; border-bottom: 1px solid black; padding-bottom: 2px;"> <span>V/f</span> <span>DTV</span> <span>PG V/f</span> <span>PG DTV</span> </div> <div style="display: flex; justify-content: space-between; border-bottom: 1px solid black; padding-bottom: 2px;"> <span>SLV</span> <span>PGV</span> <span>PM SLV</span> <span>PM PGV</span> </div> 0.00 to 590.00 Hz	0.00	Available	Hz	page 5-57
C16	Multi-step Frequency Reference 12	<div style="display: flex; justify-content: space-between; border-bottom: 1px solid black; padding-bottom: 2px;"> <span>V/f</span> <span>DTV</span> <span>PG V/f</span> <span>PG DTV</span> </div> <div style="display: flex; justify-content: space-between; border-bottom: 1px solid black; padding-bottom: 2px;"> <span>SLV</span> <span>PGV</span> <span>PM SLV</span> <span>PM PGV</span> </div> 0.00 to 590.00 Hz	0.00	Available	Hz	page 5-57
C17	Multi-step Frequency Reference 13	<div style="display: flex; justify-content: space-between; border-bottom: 1px solid black; padding-bottom: 2px;"> <span>V/f</span> <span>DTV</span> <span>PG V/f</span> <span>PG DTV</span> </div> <div style="display: flex; justify-content: space-between; border-bottom: 1px solid black; padding-bottom: 2px;"> <span>SLV</span> <span>PGV</span> <span>PM SLV</span> <span>PM PGV</span> </div> 0.00 to 590.00 Hz	0.00	Available	Hz	page 5-57
C18	Multi-step Frequency Reference 14	<div style="display: flex; justify-content: space-between; border-bottom: 1px solid black; padding-bottom: 2px;"> <span>V/f</span> <span>DTV</span> <span>PG V/f</span> <span>PG DTV</span> </div> <div style="display: flex; justify-content: space-between; border-bottom: 1px solid black; padding-bottom: 2px;"> <span>SLV</span> <span>PGV</span> <span>PM SLV</span> <span>PM PGV</span> </div> 0.00 to 590.00 Hz	0.00	Available	Hz	page 5-57
C19	Multi-step Frequency Reference 15	<div style="display: flex; justify-content: space-between; border-bottom: 1px solid black; padding-bottom: 2px;"> <span>V/f</span> <span>DTV</span> <span>PG V/f</span> <span>PG DTV</span> </div> <div style="display: flex; justify-content: space-between; border-bottom: 1px solid black; padding-bottom: 2px;"> <span>SLV</span> <span>PGV</span> <span>PM SLV</span> <span>PM PGV</span> </div> 0.00 to 590.00 Hz	0.00	Available	Hz	page 5-57
C20	Jogging Frequency	<div style="display: flex; justify-content: space-between; border-bottom: 1px solid black; padding-bottom: 2px;"> <span>V/f</span> <span>DTV</span> <span>PG V/f</span> <span>PG DTV</span> </div> <div style="display: flex; justify-content: space-between; border-bottom: 1px solid black; padding-bottom: 2px;"> <span>SLV</span> <span>PGV</span> <span>PM SLV</span> <span>PM PGV</span> </div> 0.00 to 590.00 Hz	0.00	Available	Hz	page 5-60
C21	Pattern Operation / Timed Operation Mode Selection	<div style="display: flex; justify-content: space-between; border-bottom: 1px solid black; padding-bottom: 2px;"> <span>V/f</span> <span>DTV</span> <span>PG V/f</span> <span>PG DTV</span> </div> <div style="display: flex; justify-content: space-between; border-bottom: 1px solid black; padding-bottom: 2px;"> <span>SLV</span> <span>PGV</span> <span>PM SLV</span> <span>PM PGV</span> </div> 0: 1 cycle operation (Pattern operation) 1: Repetition operation (Pattern operation) 2: Constant speed operation (Pattern operation) after 1 cycle operation 3: Timed operation	0	-	-	page 5-27

Parameter No.	Function name	Monitor or Data Range	Default data	Setting during RUN	Unit	Page
C22	Pattern Operation Stage 1 Operation Setting	<div style="display: flex; justify-content: space-between; border: 1px solid black; padding: 2px;"> <span>V/f</span> <span>DTV</span> <span>PG V/f</span> <span>PG DTV</span> </div> <div style="display: flex; justify-content: space-between; border: 1px solid black; padding: 2px; margin-top: 5px;"> <span>SLV</span> <span>PGV</span> <span>PM SLV</span> <span>PM PGV</span> </div> <p>Bit 15: 0 = Forward 1 = Reverse</p> <p>Bit 14: Fixed to 0 (Not used)</p> <p>Bit 13 to 12: Acceleration/ Deceleration time selection 0: 1st Acceleration Time 1(F007)/1st Deceleration Time 1(F008) 1: 2nd Acceleration Time 1(E010)/2nd Deceleration Time 1(E011) 2: 1st Acceleration Time 2(E012)/1st Deceleration Time 2(E013) 3: 2nd Acceleration Time 2(E014)/2nd Deceleration Time 2(E015)</p> <p>Bit 11 to 10: Minimum unit of operation time 0: 0.01 1: 0.1 2: 1 3: 10</p> <p>Bit 9 to 0: Data part of opera- tion time 0000 to 03E7 hex (0.00 to 9.99) if Minimum unit is 0: 0.01 0064 to 03E7 hex (10.0 to 99.9) if Minimum unit is 1: 0.1*1 0064 to 03E7 hex (100 to 999) if Minimum unit is 2: 1*1 0064 to 0258 hex (1,000 to 6,000) if Minimum unit is 3: 10*2 *1. 0000 to 0063 hex and 03E8 to 03FF hex cannot be set. *2. 0000 to 0063 hex and 0259 to 03FF hex cannot be set.</p>	0	Available	-	page 5-27

Parameter No.	Function name	Monitor or Data Range	Default data	Setting during RUN	Unit	Page
C23	Pattern Operation Stage 2 Operation Setting	<div style="display: flex; justify-content: space-between; border: 1px solid black; padding: 2px;"> <span>V/f</span> <span>DTV</span> <span>PG V/f</span> <span>PG DTV</span> </div> <div style="display: flex; justify-content: space-between; border: 1px solid black; padding: 2px; margin-top: 5px;"> <span>SLV</span> <span>PGV</span> <span>PM SLV</span> <span>PM PGV</span> </div> <p>Bit 15: 0 = Forward 1 = Reverse</p> <p>Bit 14: Fixed to 0 (Not used)</p> <p>Bit 13 to 12: Acceleration/Deceleration time selection 0: 1st Acceleration Time 1(F007)/1st Deceleration Time 1(F008) 1: 2nd Acceleration Time 1(E010)/2nd Deceleration Time 1(E011) 2: 1st Acceleration Time 2(E012)/1st Deceleration Time 2(E013) 3: 2nd Acceleration Time 2(E014)/2nd Deceleration Time 2(E015)</p> <p>Bit 11 to 10: Minimum unit of operation time 0: 0.01 1: 0.1 2: 1 3: 10</p> <p>Bit 9 to 0: Data part of operation time 0000 to 03E7 hex (0.00 to 9.99) if Minimum unit is 0: 0.01 0064 to 03E7 hex (10.0 to 99.9) if Minimum unit is 1: 0.1*<sup>1</sup> 0064 to 03E7 hex (100 to 999) if Minimum unit is 2: 1*<sup>1</sup> 0064 to 0258 hex (1,000 to 6,000) if Minimum unit is 3: 10*<sup>2</sup> *1. 0000 to 0063 hex and 03E8 to 03FF hex cannot be set. *2. 0000 to 0063 hex and 0259 to 03FF hex cannot be set.</p>	0	Available	-	page 5-27

Parameter No.	Function name	Monitor or Data Range	Default data	Setting during RUN	Unit	Page
C24	Pattern Operation Stage 3 Operation Setting	<div style="display: flex; justify-content: space-between; border-bottom: 1px solid black; padding-bottom: 2px;"> <span>V/f</span> <span>DTV</span> <span>PG V/f</span> <span>PG DTV</span> </div> <div style="display: flex; justify-content: space-between; border-bottom: 1px solid black; padding-bottom: 2px;"> <span>SLV</span> <span>PGV</span> <span>PM SLV</span> <span>PM PGV</span> </div> <p>Bit 15: 0 = Forward 1 = Reverse</p> <p>Bit 14: Fixed to 0 (Not used)</p> <p>Bit 13 to 12: Acceleration/ Deceleration time selection 0: 1st Acceleration Time 1(F007)/1st Deceleration Time 1(F008) 1: 2nd Acceleration Time 1(E010)/2nd Deceleration Time 1(E011) 2: 1st Acceleration Time 2(E012)/1st Deceleration Time 2(E013) 3: 2nd Acceleration Time 2(E014)/2nd Deceleration Time 2(E015)</p> <p>Bit 11 to 10: Minimum unit of operation time 0: 0.01 1: 0.1 2: 1 3: 10</p> <p>Bit 9 to 0: Data part of opera- tion time 0000 to 03E7 hex (0.00 to 9.99) if Minimum unit is 0: 0.01 0064 to 03E7 hex (10.0 to 99.9) if Minimum unit is 1: 0.1*<sup>1</sup> 0064 to 03E7 hex (100 to 999) if Minimum unit is 2: 1*<sup>1</sup> 0064 to 0258 hex (1,000 to 6,000) if Minimum unit is 3: 10*<sup>2</sup> *1. 0000 to 0063 hex and 03E8 to 03FF hex cannot be set. *2. 0000 to 0063 hex and 0259 to 03FF hex cannot be set.</p>	0	Available	-	page 5-27

Parameter No.	Function name	Monitor or Data Range	Default data	Setting during RUN	Unit	Page
C25	Pattern Operation Stage 4 Operation Setting	<div style="display: flex; justify-content: space-between; border: 1px solid black; padding: 2px;"> <span>V/f</span> <span>DTV</span> <span>PG V/f</span> <span>PG DTV</span> </div> <div style="display: flex; justify-content: space-between; border: 1px solid black; padding: 2px; margin-top: 5px;"> <span>SLV</span> <span>PGV</span> <span>PM SLV</span> <span>PM PGV</span> </div> <p>Bit 15: 0 = Forward 1 = Reverse</p> <p>Bit 14: Fixed to 0 (Not used)</p> <p>Bit 13 to 12: Acceleration/Deceleration time selection 0: 1st Acceleration Time 1(F007)/1st Deceleration Time 1(F008) 1: 2nd Acceleration Time 1(E010)/2nd Deceleration Time 1(E011) 2: 1st Acceleration Time 2(E012)/1st Deceleration Time 2(E013) 3: 2nd Acceleration Time 2(E014)/2nd Deceleration Time 2(E015)</p> <p>Bit 11 to 10: Minimum unit of operation time 0: 0.01 1: 0.1 2: 1 3: 10</p> <p>Bit 9 to 0: Data part of operation time 0000 to 03E7 hex (0.00 to 9.99) if Minimum unit is 0: 0.01 0064 to 03E7 hex (10.0 to 99.9) if Minimum unit is 1: 0.1<sup>*1</sup> 0064 to 03E7 hex (100 to 999) if Minimum unit is 2: 1<sup>*1</sup> 0064 to 0258 hex (1,000 to 6,000) if Minimum unit is 3: 10<sup>*2</sup> <sup>*1</sup>. 0000 to 0063 hex and 03E8 to 03FF hex cannot be set. <sup>*2</sup>. 0000 to 0063 hex and 0259 to 03FF hex cannot be set.</p>	0	Available	-	page 5-27

Parameter No.	Function name	Monitor or Data Range	Default data	Setting during RUN	Unit	Page
C26	Pattern Operation Stage 5 Operation Setting	<div style="display: flex; justify-content: space-between; border-bottom: 1px solid black; padding-bottom: 2px;"> <span>V/f</span> <span>DTV</span> <span>PG V/f</span> <span>PG DTV</span> </div> <div style="display: flex; justify-content: space-between; border-bottom: 1px solid black; padding-bottom: 2px;"> <span>SLV</span> <span>PGV</span> <span>PM SLV</span> <span>PM PGV</span> </div> <p>Bit 15: 0 = Forward 1 = Reverse</p> <p>Bit 14: Fixed to 0 (Not used)</p> <p>Bit 13 to 12: Acceleration/ Deceleration time selection 0: 1st Acceleration Time 1(F007)/1st Deceleration Time 1(F008) 1: 2nd Acceleration Time 1(E010)/2nd Deceleration Time 1(E011) 2: 1st Acceleration Time 2(E012)/1st Deceleration Time 2(E013) 3: 2nd Acceleration Time 2(E014)/2nd Deceleration Time 2(E015)</p> <p>Bit 11 to 10: Minimum unit of operation time 0: 0.01 1: 0.1 2: 1 3: 10</p> <p>Bit 9 to 0: Data part of opera- tion time 0000 to 03E7 hex (0.00 to 9.99) if Minimum unit is 0: 0.01 0064 to 03E7 hex (10.0 to 99.9) if Minimum unit is 1: 0.1*<sup>1</sup> 0064 to 03E7 hex (100 to 999) if Minimum unit is 2: 1*<sup>1</sup> 0064 to 0258 hex (1,000 to 6,000) if Minimum unit is 3: 10*<sup>2</sup> *1. 0000 to 0063 hex and 03E8 to 03FF hex cannot be set. *2. 0000 to 0063 hex and 0259 to 03FF hex cannot be set.</p>	0	Available	-	page 5-27



Parameter No.	Function name	Monitor or Data Range	Default data	Setting during RUN	Unit	Page
C27	Pattern Operation Stage 6 Operation Setting	<div style="display: flex; justify-content: space-between; border: 1px solid black; padding: 2px;"> <span>V/f</span> <span>DTV</span> <span>PG V/f</span> <span>PG DTV</span> </div> <div style="display: flex; justify-content: space-between; border: 1px solid black; padding: 2px; margin-top: 5px;"> <span>SLV</span> <span>PGV</span> <span>PM SLV</span> <span>PM PGV</span> </div> <p>Bit 15: 0 = Forward 1 = Reverse</p> <p>Bit 14: Fixed to 0 (Not used)</p> <p>Bit 13 to 12: Acceleration/Deceleration time selection 0: 1st Acceleration Time 1(F007)/1st Deceleration Time 1(F008) 1: 2nd Acceleration Time 1(E010)/2nd Deceleration Time 1(E011) 2: 1st Acceleration Time 2(E012)/1st Deceleration Time 2(E013) 3: 2nd Acceleration Time 2(E014)/2nd Deceleration Time 2(E015)</p> <p>Bit 11 to 10: Minimum unit of operation time 0: 0.01 1: 0.1 2: 1 3: 10</p> <p>Bit 9 to 0: Data part of operation time 0000 to 03E7 hex (0.00 to 9.99) if Minimum unit is 0: 0.01 0064 to 03E7 hex (10.0 to 99.9) if Minimum unit is 1: 0.1*<sup>1</sup> 0064 to 03E7 hex (100 to 999) if Minimum unit is 2: 1*<sup>1</sup> 0064 to 0258 hex (1,000 to 6,000) if Minimum unit is 3: 10*<sup>2</sup> *1. 0000 to 0063 hex and 03E8 to 03FF hex cannot be set. *2. 0000 to 0063 hex and 0259 to 03FF hex cannot be set.</p>	0	Available	-	page 5-27

Parameter No.	Function name	Monitor or Data Range	Default data	Setting during RUN	Unit	Page
C28	Pattern Operation Stage 7 Operation Setting	<div style="display: flex; justify-content: space-between; border-bottom: 1px solid black; padding-bottom: 2px;"> <span>V/f</span> <span>DTV</span> <span>PG V/f</span> <span>PG DTV</span> </div> <div style="display: flex; justify-content: space-between; border-bottom: 1px solid black; padding-bottom: 2px;"> <span>SLV</span> <span>PGV</span> <span>PM SLV</span> <span>PM PGV</span> </div> <p>Bit 15: 0 = Forward 1 = Reverse</p> <p>Bit 14: Fixed to 0 (Not used)</p> <p>Bit 13 to 12: Acceleration/ Deceleration time selection 0: 1st Acceleration Time 1(F007)/1st Deceleration Time 1(F008) 1: 2nd Acceleration Time 1(E010)/2nd Deceleration Time 1(E011) 2: 1st Acceleration Time 2(E012)/1st Deceleration Time 2(E013) 3: 2nd Acceleration Time 2(E014)/2nd Deceleration Time 2(E015)</p> <p>Bit 11 to 10: Minimum unit of operation time 0: 0.01 1: 0.1 2: 1 3: 10</p> <p>Bit 9 to 0: Data part of opera- tion time 0000 to 03E7 hex (0.00 to 9.99) if Minimum unit is 0: 0.01 0064 to 03E7 hex (10.0 to 99.9) if Minimum unit is 1: 0.1*<sup>1</sup> 0064 to 03E7 hex (100 to 999) if Minimum unit is 2: 1*<sup>1</sup> 0064 to 0258 hex (1,000 to 6,000) if Minimum unit is 3: 10*<sup>2</sup> *1. 0000 to 0063 hex and 03E8 to 03FF hex cannot be set. *2. 0000 to 0063 hex and 0259 to 03FF hex cannot be set.</p>	0	Available	-	page 5-27

Parameter No.	Function name	Monitor or Data Range	Default data	Setting during RUN	Unit	Page
C30	2nd Frequency Reference Selection	<div style="display: flex; justify-content: space-between; margin-bottom: 5px;"> <span>V/f</span> <span>DTV</span> <span>PG V/f</span> <span>PG DTV</span> </div> <div style="display: flex; justify-content: space-between; margin-bottom: 5px;"> <span>SLV</span> <span>PGV</span> <span>PM SLV</span> <span>PM PGV</span> </div> 0: Operator (Up/Down keys) (balancelessbumpless switching unavailable) 1: Analog voltage input (terminal AI1) 2: Analog current input (terminal AI2 (All)) 3: Analog voltage input (terminal AI1) + analog current input (terminal AI2 (All)) 5: Analog voltage input (terminal AI2 (AIV)) 7: UP/DWN control 8: Operator (UP and DOWN keys) (balancelessbumpless switching available) 10: Pattern operation/ timed operation 12: Pulse train input 13: Calculation result 14: RS-485 communication 15: Fieldbus (Reserved)	2	-	-	page 5-27
C31	Input Terminal [AI1] Offset	<div style="display: flex; justify-content: space-between; margin-bottom: 5px;"> <span>V/f</span> <span>DTV</span> <span>PG V/f</span> <span>PG DTV</span> </div> <div style="display: flex; justify-content: space-between; margin-bottom: 5px;"> <span>SLV</span> <span>PGV</span> <span>PM SLV</span> <span>PM PGV</span> </div> -5.0 to 5.0 %	0.0	Available	%	page 7-38 page 7-123
C32	Input Terminal [AI1] Gain (Command)	<div style="display: flex; justify-content: space-between; margin-bottom: 5px;"> <span>V/f</span> <span>DTV</span> <span>PG V/f</span> <span>PG DTV</span> </div> <div style="display: flex; justify-content: space-between; margin-bottom: 5px;"> <span>SLV</span> <span>PGV</span> <span>PM SLV</span> <span>PM PGV</span> </div> 0.00 to 400.00 %	100.00	Available	%	page 7-38 page 7-123
C33	Input Terminal [AI1] Filter	<div style="display: flex; justify-content: space-between; margin-bottom: 5px;"> <span>V/f</span> <span>DTV</span> <span>PG V/f</span> <span>PG DTV</span> </div> <div style="display: flex; justify-content: space-between; margin-bottom: 5px;"> <span>SLV</span> <span>PGV</span> <span>PM SLV</span> <span>PM PGV</span> </div> 0.00 to 5.00 s	0.05	Available	s	page 7-123
C34	Input Terminal [AI1] Gain (Analog Input)	<div style="display: flex; justify-content: space-between; margin-bottom: 5px;"> <span>V/f</span> <span>DTV</span> <span>PG V/f</span> <span>PG DTV</span> </div> <div style="display: flex; justify-content: space-between; margin-bottom: 5px;"> <span>SLV</span> <span>PGV</span> <span>PM SLV</span> <span>PM PGV</span> </div> 0.00 to 100.00 %	100.00	Available	%	page 7-38 page 7-123
C35	Input Terminal [AI1] Polarity Selection	<div style="display: flex; justify-content: space-between; margin-bottom: 5px;"> <span>V/f</span> <span>DTV</span> <span>PG V/f</span> <span>PG DTV</span> </div> <div style="display: flex; justify-content: space-between; margin-bottom: 5px;"> <span>SLV</span> <span>PGV</span> <span>PM SLV</span> <span>PM PGV</span> </div> 0: Bipolar 1: Unipolar	1	-	-	page 7-38 page 7-123
C36	Input Terminal [AI2] Offset (All)	<div style="display: flex; justify-content: space-between; margin-bottom: 5px;"> <span>V/f</span> <span>DTV</span> <span>PG V/f</span> <span>PG DTV</span> </div> <div style="display: flex; justify-content: space-between; margin-bottom: 5px;"> <span>SLV</span> <span>PGV</span> <span>PM SLV</span> <span>PM PGV</span> </div> -5.0 to 5.0 %	0.0	Available	%	page 7-38 page 7-123

Parameter No.	Function name	Monitor or Data Range	Default data	Setting during RUN	Unit	Page
C37	Input Terminal [AI2] Gain (All Command)	<input type="button" value="V/f"/> <input type="button" value="DTV"/> <input type="button" value="PG V/f"/> <input type="button" value="PG DTV"/> <input type="button" value="SLV"/> <input type="button" value="PGV"/> <input type="button" value="PM SLV"/> <input type="button" value="PM PGV"/> 0.00 to 400.00 %	100.00	Available	%	page 7-38 page 7-123
C38	Input Terminal [AI2] Filter (All)	<input type="button" value="V/f"/> <input type="button" value="DTV"/> <input type="button" value="PG V/f"/> <input type="button" value="PG DTV"/> <input type="button" value="SLV"/> <input type="button" value="PGV"/> <input type="button" value="PM SLV"/> <input type="button" value="PM PGV"/> 0.00 to 5.00 s	0.05	Available	s	page 7-123
C39	Input Terminal [AI2] Gain (All Analog Input)	<input type="button" value="V/f"/> <input type="button" value="DTV"/> <input type="button" value="PG V/f"/> <input type="button" value="PG DTV"/> <input type="button" value="SLV"/> <input type="button" value="PGV"/> <input type="button" value="PM SLV"/> <input type="button" value="PM PGV"/> 0.00 to 100.00 %	100.00	Available	%	page 7-38 page 7-123
C40	Input Terminal [AI2] Operation Selection (All)	<input type="button" value="V/f"/> <input type="button" value="DTV"/> <input type="button" value="PG V/f"/> <input type="button" value="PG DTV"/> <input type="button" value="SLV"/> <input type="button" value="PGV"/> <input type="button" value="PM SLV"/> <input type="button" value="PM PGV"/> 0: 4 to 20mA Unipolar 1: 0 to 20mA Unipolar 10: 4 to 20mA Bipolar 11: 0 to 20mA Bipolar	0	-	-	page 7-38 page 7-123
C41	Input Terminal [AI2] Offset (AIV)	<input type="button" value="V/f"/> <input type="button" value="DTV"/> <input type="button" value="PG V/f"/> <input type="button" value="PG DTV"/> <input type="button" value="SLV"/> <input type="button" value="PGV"/> <input type="button" value="PM SLV"/> <input type="button" value="PM PGV"/> -5.0 to 5.0 %	0.0	Available	%	page 7-38 page 7-123
C42	Input Terminal [AI2] Gain (AIV Command)	<input type="button" value="V/f"/> <input type="button" value="DTV"/> <input type="button" value="PG V/f"/> <input type="button" value="PG DTV"/> <input type="button" value="SLV"/> <input type="button" value="PGV"/> <input type="button" value="PM SLV"/> <input type="button" value="PM PGV"/> 0.00 to 400.00 %	100.00	Available	%	page 7-38 page 7-123
C43	Input Terminal [AI2] Filter (AIV)	<input type="button" value="V/f"/> <input type="button" value="DTV"/> <input type="button" value="PG V/f"/> <input type="button" value="PG DTV"/> <input type="button" value="SLV"/> <input type="button" value="PGV"/> <input type="button" value="PM SLV"/> <input type="button" value="PM PGV"/> 0.00 to 5.00 s	0.05	Available	s	page 7-123
C44	Input Terminal [AI2] Gain (AIV Analog Input)	<input type="button" value="V/f"/> <input type="button" value="DTV"/> <input type="button" value="PG V/f"/> <input type="button" value="PG DTV"/> <input type="button" value="SLV"/> <input type="button" value="PGV"/> <input type="button" value="PM SLV"/> <input type="button" value="PM PGV"/> 0.00 to 100.00 %	100.00	Available	%	page 7-38 page 7-123
C45	Input Terminal [AI2] Polarity Selection (AIV)	<input type="button" value="V/f"/> <input type="button" value="DTV"/> <input type="button" value="PG V/f"/> <input type="button" value="PG DTV"/> <input type="button" value="SLV"/> <input type="button" value="PGV"/> <input type="button" value="PM SLV"/> <input type="button" value="PM PGV"/> 0: Bipolar 1: Unipolar	1	-	-	page 7-38 page 7-123
C50	Input Terminal [AI1, AI2] Bias Analog Input for 1st Frequency Command	<input type="button" value="V/f"/> <input type="button" value="DTV"/> <input type="button" value="PG V/f"/> <input type="button" value="PG DTV"/> <input type="button" value="SLV"/> <input type="button" value="PGV"/> <input type="button" value="PM SLV"/> <input type="button" value="PM PGV"/> 0.00 to 100.00 %	0.00	Available	%	page 7-38
C53	Input Terminal [AI1, AI2] Normal/Inverse Operation for 1st Frequency Command	<input type="button" value="V/f"/> <input type="button" value="DTV"/> <input type="button" value="PG V/f"/> <input type="button" value="PG DTV"/> <input type="button" value="SLV"/> <input type="button" value="PGV"/> <input type="button" value="PM SLV"/> <input type="button" value="PM PGV"/> 0: Normal 1: Inverse	0	Available	-	page 7-44

Parameter No.	Function name	Monitor or Data Range	Default data	Setting during RUN	Unit	Page
C54	Input Terminal [AI1, AI2] Normal/Inverse Operation for 2nd Frequency Command	<input type="checkbox"/> V/f <input type="checkbox"/> DTV <input type="checkbox"/> PG V/f <input type="checkbox"/> PG DTV <input type="checkbox"/> SLV <input type="checkbox"/> PGV <input type="checkbox"/> PM SLV <input type="checkbox"/> PM PGV 0: Normal 1: Inverse	0	Available	-	page 7-44
C55	Input Terminal [AI1] Bias (Command)	<input type="checkbox"/> V/f <input type="checkbox"/> DTV <input type="checkbox"/> PG V/f <input type="checkbox"/> PG DTV <input type="checkbox"/> SLV <input type="checkbox"/> PGV <input type="checkbox"/> PM SLV <input type="checkbox"/> PM PGV -200.00 to 200.00 %	0.00	Available	%	page 7-38 page 7-123
C56	Input Terminal [AI1] Bias (Analog Input)	<input type="checkbox"/> V/f <input type="checkbox"/> DTV <input type="checkbox"/> PG V/f <input type="checkbox"/> PG DTV <input type="checkbox"/> SLV <input type="checkbox"/> PGV <input type="checkbox"/> PM SLV <input type="checkbox"/> PM PGV 0.00 to 100.00 %	0.00	Available	%	page 7-38
C58	Do not use	-	-	-	-	-
C59	Input Terminal [AI1] Analog Input Adjustment Maximum Scale	<input type="checkbox"/> V/f <input type="checkbox"/> DTV <input type="checkbox"/> PG V/f <input type="checkbox"/> PG DTV <input type="checkbox"/> SLV <input type="checkbox"/> PGV <input type="checkbox"/> PM SLV <input type="checkbox"/> PM PGV -999.00 to 0.00 to 9,990.00	100	-	-	page 7-123
C60	Input Terminal [AI1] Analog Input Adjustment Minimum Scale	<input type="checkbox"/> V/f <input type="checkbox"/> DTV <input type="checkbox"/> PG V/f <input type="checkbox"/> PG DTV <input type="checkbox"/> SLV <input type="checkbox"/> PGV <input type="checkbox"/> PM SLV <input type="checkbox"/> PM PGV -999.00 to 0.00 to 9,990.00	0	-	-	page 7-38 page 7-123
C61	Input Terminal [AI2] Bias (All Command)	<input type="checkbox"/> V/f <input type="checkbox"/> DTV <input type="checkbox"/> PG V/f <input type="checkbox"/> PG DTV <input type="checkbox"/> SLV <input type="checkbox"/> PGV <input type="checkbox"/> PM SLV <input type="checkbox"/> PM PGV -200.00 to 200.00 %	0.00	Available	%	page 7-38 page 7-123
C62	Input Terminal [AI2] Bias (All Analog Input)	<input type="checkbox"/> V/f <input type="checkbox"/> DTV <input type="checkbox"/> PG V/f <input type="checkbox"/> PG DTV <input type="checkbox"/> SLV <input type="checkbox"/> PGV <input type="checkbox"/> PM SLV <input type="checkbox"/> PM PGV 0.00 to 100.00 %	0.00	Available	%	page 7-38
C64	Do not use	-	-	-	-	-
C65	Input Terminal [AI2] Analog Input Adjustment Maximum Scale (All)	<input type="checkbox"/> V/f <input type="checkbox"/> DTV <input type="checkbox"/> PG V/f <input type="checkbox"/> PG DTV <input type="checkbox"/> SLV <input type="checkbox"/> PGV <input type="checkbox"/> PM SLV <input type="checkbox"/> PM PGV -999.00 to 0.00 to 9990.00	100	-	-	page 7-123
C66	Input Terminal [AI2] Analog Input Adjustment Minimum Scale (All)	<input type="checkbox"/> V/f <input type="checkbox"/> DTV <input type="checkbox"/> PG V/f <input type="checkbox"/> PG DTV <input type="checkbox"/> SLV <input type="checkbox"/> PGV <input type="checkbox"/> PM SLV <input type="checkbox"/> PM PGV -999.00 to 0.00 to 9990.00	0	-	-	page 7-123
C67	Input Terminal [AI2] Bias (AIV Command)	<input type="checkbox"/> V/f <input type="checkbox"/> DTV <input type="checkbox"/> PG V/f <input type="checkbox"/> PG DTV <input type="checkbox"/> SLV <input type="checkbox"/> PGV <input type="checkbox"/> PM SLV <input type="checkbox"/> PM PGV -200.00 to 200.00 %	0.00	Available	%	page 7-38 page 7-123
C68	Input Terminal [AI2] Bias (AIV Analog Input)	<input type="checkbox"/> V/f <input type="checkbox"/> DTV <input type="checkbox"/> PG V/f <input type="checkbox"/> PG DTV <input type="checkbox"/> SLV <input type="checkbox"/> PGV <input type="checkbox"/> PM SLV <input type="checkbox"/> PM PGV 0.00 to 100.00 %	0.00	Available	%	page 7-38 page 7-123
C70	Do not use	-	-	-	-	-

Parameter No.	Function name	Monitor or Data Range	Default data	Setting during RUN	Unit	Page
C71	Input Terminal [AI2] Analog Input Adjustment Maximum Scale (AIV)	V/f DTV PG V/f PG DTV SLV PGV PM SLV PM PGV -999.00 to 0.00 to 9990.00	100	-	-	page 7-123
C72	Input Terminal [AI2] Analog Input Adjustment Minimum Scale (AIV)	V/f DTV PG V/f PG DTV SLV PGV PM SLV PM PGV -999.00 to 0.00 to 9990.00	0	-	-	page 7-123
C89	Set-point Factor Numerator via Communication	V/f DTV PG V/f PG DTV SLV PGV PM SLV PM PGV -32768 to 32767	1	Available	-	page 8-87
C90	Set-point Factor Denominator via Communication	V/f DTV PG V/f PG DTV SLV PGV PM SLV PM PGV -32768 to 32767	1	Available	-	page 8-87
C99	1st Frequency Reference/1st Multi-step Frequency Reference 0	V/f DTV PG V/f PG DTV SLV PGV PM SLV PM PGV 0.0 to 590.00 Hz	0.00	Available	Hz	page 5-27

#### 4-2-4 Parameter P (Motor 1 Parameter)

Parameter No.	Function name	Monitor or Data Range	Default data	Setting during RUN	Unit	Page
P01	1st Motor Pole Number	V/f DTV PG V/f PG DTV SLV PGV PM SLV PM PGV 2 to 128 poles	4	-	Pole	page 5-19 page 6-4
P02	1st Motor Capacity	V/f DTV PG V/f PG DTV SLV PGV PM SLV PM PGV 0.01 to 1000 kW	5.50	-	kW	page 5-19 page 6-4
P03	1st Motor Rated Current	V/f DTV PG V/f PG DTV SLV PGV PM SLV PM PGV 0.00 to 500.0 A	21	-	A	page 6-4

Parameter No.	Function name	Monitor or Data Range	Default data	Setting during RUN	Unit	Page
P04	1st Auto Tuning Function Selection	<div style="display: flex; justify-content: space-between; border-bottom: 1px solid black; padding-bottom: 2px;"> <span>V/f</span> <span>DTV</span> <span>PG V/f</span> <span>PG DTV</span> </div> <div style="display: flex; justify-content: space-between; border-bottom: 1px solid black; padding-bottom: 2px;"> <span>SLV</span> <span>PGV</span> <span>PM SLV</span> <span>PM PGV</span> </div> <p>0: Disable            1: Tune the motor parameters while stopped            2: Tune the motor parameters while rotating            4: Tune the PM motor magnetic pole position offset while rotating            5: Tune the motor %R1 and %X while stopped</p>	0	-	-	page 6-65
P05	1st Online Tuning Function Selection	<div style="display: flex; justify-content: space-between; border-bottom: 1px solid black; padding-bottom: 2px;"> <span>V/f</span> <span>DTV</span> <span>PG V/f</span> <span>PG DTV</span> </div> <div style="display: flex; justify-content: space-between; border-bottom: 1px solid black; padding-bottom: 2px;"> <span>SLV</span> <span>PGV</span> <span>PM SLV</span> <span>PM PGV</span> </div> <p>0: Disable            1: Enable</p>	0	Available	-	page 6-71
P06	1st Motor Armature Resistance	<div style="display: flex; justify-content: space-between; border-bottom: 1px solid black; padding-bottom: 2px;"> <span>V/f</span> <span>DTV</span> <span>PG V/f</span> <span>PG DTV</span> </div> <div style="display: flex; justify-content: space-between; border-bottom: 1px solid black; padding-bottom: 2px;"> <span>SLV</span> <span>PGV</span> <span>PM SLV</span> <span>PM PGV</span> </div> <p>0.00 to 500.0 A</p>	10.55	-	A	page 6-6
P07	1st Motor Parameter %R1	<div style="display: flex; justify-content: space-between; border-bottom: 1px solid black; padding-bottom: 2px;"> <span>V/f</span> <span>DTV</span> <span>PG V/f</span> <span>PG DTV</span> </div> <div style="display: flex; justify-content: space-between; border-bottom: 1px solid black; padding-bottom: 2px;"> <span>SLV</span> <span>PGV</span> <span>PM SLV</span> <span>PM PGV</span> </div> <p>0.00 to 50.00 %</p>	3.17	Available	%	page 6-65
P08	1st Motor Parameter %X	<div style="display: flex; justify-content: space-between; border-bottom: 1px solid black; padding-bottom: 2px;"> <span>V/f</span> <span>DTV</span> <span>PG V/f</span> <span>PG DTV</span> </div> <div style="display: flex; justify-content: space-between; border-bottom: 1px solid black; padding-bottom: 2px;"> <span>SLV</span> <span>PGV</span> <span>PM SLV</span> <span>PM PGV</span> </div> <p>0.00 to 50.00 %</p>	11.47	Available	%	page 6-65
P09	1st Slip Compensation Gain for Driving	<div style="display: flex; justify-content: space-between; border-bottom: 1px solid black; padding-bottom: 2px;"> <span>V/f</span> <span>DTV</span> <span>PG V/f</span> <span>PG DTV</span> </div> <div style="display: flex; justify-content: space-between; border-bottom: 1px solid black; padding-bottom: 2px;"> <span>SLV</span> <span>PGV</span> <span>PM SLV</span> <span>PM PGV</span> </div> <p>0.0 to 200.0 %</p>	100.0	Available	%	page 5-16
P10	1st Slip Compensation Response Time	<div style="display: flex; justify-content: space-between; border-bottom: 1px solid black; padding-bottom: 2px;"> <span>V/f</span> <span>DTV</span> <span>PG V/f</span> <span>PG DTV</span> </div> <div style="display: flex; justify-content: space-between; border-bottom: 1px solid black; padding-bottom: 2px;"> <span>SLV</span> <span>PGV</span> <span>PM SLV</span> <span>PM PGV</span> </div> <p>0.01 to 10.00 s</p>	0.12	Available	s	page 5-16
P11	1st Slip Compensation Gain for Braking	<div style="display: flex; justify-content: space-between; border-bottom: 1px solid black; padding-bottom: 2px;"> <span>V/f</span> <span>DTV</span> <span>PG V/f</span> <span>PG DTV</span> </div> <div style="display: flex; justify-content: space-between; border-bottom: 1px solid black; padding-bottom: 2px;"> <span>SLV</span> <span>PGV</span> <span>PM SLV</span> <span>PM PGV</span> </div> <p>0.0 to 200.0 %</p>	100.0	Available	%	page 5-16
P12	1st Rated Slip Frequency	<div style="display: flex; justify-content: space-between; border-bottom: 1px solid black; padding-bottom: 2px;"> <span>V/f</span> <span>DTV</span> <span>PG V/f</span> <span>PG DTV</span> </div> <div style="display: flex; justify-content: space-between; border-bottom: 1px solid black; padding-bottom: 2px;"> <span>SLV</span> <span>PGV</span> <span>PM SLV</span> <span>PM PGV</span> </div> <p>0.00 to 15.00 Hz</p>	1	-	Hz	page 5-16
P13	1st Iron Loss Factor 1	<div style="display: flex; justify-content: space-between; border-bottom: 1px solid black; padding-bottom: 2px;"> <span>V/f</span> <span>DTV</span> <span>PG V/f</span> <span>PG DTV</span> </div> <div style="display: flex; justify-content: space-between; border-bottom: 1px solid black; padding-bottom: 2px;"> <span>SLV</span> <span>PGV</span> <span>PM SLV</span> <span>PM PGV</span> </div> <p>0.00 to 20.00 %</p>	2.86	Available	%	page 6-6

Parameter No.	Function name	Monitor or Data Range	Default data	Setting during RUN	Unit	Page
P16	1st Magnetic Saturation Factor 1	<div style="display: flex; justify-content: space-between; font-size: small;"> <span>V/f</span> <span>DTV</span> <span>PG V/f</span> <span>PG DTV</span> </div> <div style="display: flex; justify-content: space-between; font-size: small;"> <span>SLV</span> <span>PGV</span> <span>PM SLV</span> <span>PM PGV</span> </div> 0.0 to 300.0 %	92	Available	%	page 6-65
P17	1st Magnetic Saturation Factor 2	<div style="display: flex; justify-content: space-between; font-size: small;"> <span>V/f</span> <span>DTV</span> <span>PG V/f</span> <span>PG DTV</span> </div> <div style="display: flex; justify-content: space-between; font-size: small;"> <span>SLV</span> <span>PGV</span> <span>PM SLV</span> <span>PM PGV</span> </div> 0.0 to 300.0 %	84.2	Available	%	page 6-65
P18	1st Magnetic Saturation Factor 3	<div style="display: flex; justify-content: space-between; font-size: small;"> <span>V/f</span> <span>DTV</span> <span>PG V/f</span> <span>PG DTV</span> </div> <div style="display: flex; justify-content: space-between; font-size: small;"> <span>SLV</span> <span>PGV</span> <span>PM SLV</span> <span>PM PGV</span> </div> 0.0 to 300.0 %	70.5	Available	%	page 6-65
P19	1st Magnetic Saturation Factor 4	<div style="display: flex; justify-content: space-between; font-size: small;"> <span>V/f</span> <span>DTV</span> <span>PG V/f</span> <span>PG DTV</span> </div> <div style="display: flex; justify-content: space-between; font-size: small;"> <span>SLV</span> <span>PGV</span> <span>PM SLV</span> <span>PM PGV</span> </div> 0.0 to 300.0 %	58.3	Available	%	page 6-65
P20	1st Magnetic Saturation Factor 5	<div style="display: flex; justify-content: space-between; font-size: small;"> <span>V/f</span> <span>DTV</span> <span>PG V/f</span> <span>PG DTV</span> </div> <div style="display: flex; justify-content: space-between; font-size: small;"> <span>SLV</span> <span>PGV</span> <span>PM SLV</span> <span>PM PGV</span> </div> 0.0 to 300.0 %	46.1	Available	%	page 6-65
P30	1st PM Motor Starting Method	<div style="display: flex; justify-content: space-between; font-size: small;"> <span>V/f</span> <span>DTV</span> <span>PG V/f</span> <span>PG DTV</span> </div> <div style="display: flex; justify-content: space-between; font-size: small;"> <span>SLV</span> <span>PGV</span> <span>PM SLV</span> <span>PM PGV</span> </div> 0: Pull-in by current 1: IPM motor type 1 2: SPM motor type 3: Pull-in by current for IPM motor 4: IPM motor type 2	1	-	-	page 6-6 page 6-22
P40	Do not use	-	-	-	-	-
P41	Do not use	-	-	-	-	-
P53	1st Motor %X Correction Factor	<div style="display: flex; justify-content: space-between; font-size: small;"> <span>V/f</span> <span>DTV</span> <span>PG V/f</span> <span>PG DTV</span> </div> <div style="display: flex; justify-content: space-between; font-size: small;"> <span>SLV</span> <span>PGV</span> <span>PM SLV</span> <span>PM PGV</span> </div> 0 to 300 %	100	Available	%	page 6-65
P55	1st Motor Torque Current under Vector Control	<div style="display: flex; justify-content: space-between; font-size: small;"> <span>V/f</span> <span>DTV</span> <span>PG V/f</span> <span>PG DTV</span> </div> <div style="display: flex; justify-content: space-between; font-size: small;"> <span>SLV</span> <span>PGV</span> <span>PM SLV</span> <span>PM PGV</span> </div> 0.00 to 500.0 A	16.71	-	A	page 6-6
P56	1st Induced Voltage Factor under Vector Control	<div style="display: flex; justify-content: space-between; font-size: small;"> <span>V/f</span> <span>DTV</span> <span>PG V/f</span> <span>PG DTV</span> </div> <div style="display: flex; justify-content: space-between; font-size: small;"> <span>SLV</span> <span>PGV</span> <span>PM SLV</span> <span>PM PGV</span> </div> 50 to 100 %	95	-	%	page 6-6
P57	Do not use	-	-	-	-	-
P60	1st PM Motor Armature Resistance	<div style="display: flex; justify-content: space-between; font-size: small;"> <span>V/f</span> <span>DTV</span> <span>PG V/f</span> <span>PG DTV</span> </div> <div style="display: flex; justify-content: space-between; font-size: small;"> <span>SLV</span> <span>PGV</span> <span>PM SLV</span> <span>PM PGV</span> </div> 0.000 to 50.00 ohm	0.253	-	ohm	page 6-65



Parameter No.	Function name	Monitor or Data Range	Default data	Setting during RUN	Unit	Page
P61	1st PM Motor d-axis Inductance	<div style="display: flex; justify-content: space-between; font-size: small;"> <span>V/f</span> <span>DTV</span> <span>PG V/f</span> <span>PG DTV</span> </div> <div style="display: flex; justify-content: space-between; font-size: small;"> <span>SLV</span> <span>PGV</span> <span>PM SLV</span> <span>PM PGV</span> </div> 0.00 to 500.0mH	4.77	-	mH	page 6-65 page 6-22
P62	1st PM Motor q-axis Inductance	<div style="display: flex; justify-content: space-between; font-size: small;"> <span>V/f</span> <span>DTV</span> <span>PG V/f</span> <span>PG DTV</span> </div> <div style="display: flex; justify-content: space-between; font-size: small;"> <span>SLV</span> <span>PGV</span> <span>PM SLV</span> <span>PM PGV</span> </div> 0.00 to 500.0mH	10.70	-	mH	page 6-65 page 6-22
P63	1st PM Motor Induced Voltage Ke	<div style="display: flex; justify-content: space-between; font-size: small;"> <span>V/f</span> <span>DTV</span> <span>PG V/f</span> <span>PG DTV</span> </div> <div style="display: flex; justify-content: space-between; font-size: small;"> <span>SLV</span> <span>PGV</span> <span>PM SLV</span> <span>PM PGV</span> </div> 0 to 240 V (200 V class series) 0 to 500 V: (400 V class series) Voltage at rated speed	177	-	V	page 6-6
P64	1st PM Motor Iron Loss	<div style="display: flex; justify-content: space-between; font-size: small;"> <span>V/f</span> <span>DTV</span> <span>PG V/f</span> <span>PG DTV</span> </div> <div style="display: flex; justify-content: space-between; font-size: small;"> <span>SLV</span> <span>PGV</span> <span>PM SLV</span> <span>PM PGV</span> </div> 0.0 to 20.0% 100% = Motor rated current Iron loss at rated speed	5.50	Available	%	page 6-6
P65	1st PM Motor d-axis Inductance Magnetic Saturation Correction	<div style="display: flex; justify-content: space-between; font-size: small;"> <span>V/f</span> <span>DTV</span> <span>PG V/f</span> <span>PG DTV</span> </div> <div style="display: flex; justify-content: space-between; font-size: small;"> <span>SLV</span> <span>PGV</span> <span>PM SLV</span> <span>PM PGV</span> </div> 0.0 to 100.0% 999: Factory default 100.0% = No magnetic saturation	32767	Available	%	page 6-6
P74	1st PM Motor Reference Current at Starting	<div style="display: flex; justify-content: space-between; font-size: small;"> <span>V/f</span> <span>DTV</span> <span>PG V/f</span> <span>PG DTV</span> </div> <div style="display: flex; justify-content: space-between; font-size: small;"> <span>SLV</span> <span>PGV</span> <span>PM SLV</span> <span>PM PGV</span> </div> 10 to 200% 100% = Motor rated current	80	Available	%	page 6-6 page 6-22
P83	Do not use	-	-	-	-	-
P84	Do not use	-	-	-	-	-
P85	1st PM Motor Flux Limitation Value	<div style="display: flex; justify-content: space-between; font-size: small;"> <span>V/f</span> <span>DTV</span> <span>PG V/f</span> <span>PG DTV</span> </div> <div style="display: flex; justify-content: space-between; font-size: small;"> <span>SLV</span> <span>PGV</span> <span>PM SLV</span> <span>PM PGV</span> </div> 50.0 to 150.0% 999: Factory default	32767	Available	%	page 6-6
P86	Do not use	-	-	-	-	-
P87	1st PM Motor Reference Current for Magnetic Pole Detection	<div style="display: flex; justify-content: space-between; font-size: small;"> <span>V/f</span> <span>DTV</span> <span>PG V/f</span> <span>PG DTV</span> </div> <div style="display: flex; justify-content: space-between; font-size: small;"> <span>SLV</span> <span>PGV</span> <span>PM SLV</span> <span>PM PGV</span> </div> 0 to 200% Based on the rated current of the motor	60	-	%	page 6-6
P88	Do not use	-	-	-	-	-
P89	Do not use	-	-	-	-	-

Parameter No.	Function name	Monitor or Data Range	Default data	Setting during RUN	Unit	Page
P90	1st PM Motor Overcurrent Protection Level	<div style="display: flex; justify-content: space-between; font-size: small;"> <span>V/f</span> <span>DTV</span> <span>PG V/f</span> <span>PG DTV</span> </div> <div style="display: flex; justify-content: space-between; font-size: small;"> <span>SLV</span> <span>PGV</span> <span>PM SLV</span> <span>PM PGV</span> </div> 0.00 ; 0.01 to 500.0 0.00 : Disable 0.01 to 500.0 A	50.00	-	A	page 6-22
P95	1st PM Motor Magnetic Pole position Offset	<div style="display: flex; justify-content: space-between; font-size: small;"> <span>V/f</span> <span>DTV</span> <span>PG V/f</span> <span>PG DTV</span> </div> <div style="display: flex; justify-content: space-between; font-size: small;"> <span>SLV</span> <span>PGV</span> <span>PM SLV</span> <span>PM PGV</span> </div> 0.0 to 359.9° 999: Offset not adjusted	32767	Available	deg	page 6-65

### 4-2-5 Parameter H (High Level Functions)

Parameter No.	Function name	Monitor or Data Range	Default data	Setting during RUN	Unit	Page
H03	Data Initialization	<div style="display: flex; justify-content: space-between; font-size: small;"> <span>V/f</span> <span>DTV</span> <span>PG V/f</span> <span>PG DTV</span> </div> <div style="display: flex; justify-content: space-between; font-size: small;"> <span>SLV</span> <span>PGV</span> <span>PM SLV</span> <span>PM PGV</span> </div> 0: Disable 1: Initialize all parameters 2: Initialize motor 1 parameters 3: Initialize motor 2 parameters 4: Restore user defined data 5: Initialize all parameters (except I/O and communications) 6: Reserved 7: Clear alarm history 8: Clear selection of favorite function code	0	-	-	page 5-4
H04	Retry Count at Trip	<div style="display: flex; justify-content: space-between; font-size: small;"> <span>V/f</span> <span>DTV</span> <span>PG V/f</span> <span>PG DTV</span> </div> <div style="display: flex; justify-content: space-between; font-size: small;"> <span>SLV</span> <span>PGV</span> <span>PM SLV</span> <span>PM PGV</span> </div> 0: Disable 1 to 20: Number of retries	0	Available	-	page 7-58
H05	Retry Standby Time at Trip	<div style="display: flex; justify-content: space-between; font-size: small;"> <span>V/f</span> <span>DTV</span> <span>PG V/f</span> <span>PG DTV</span> </div> <div style="display: flex; justify-content: space-between; font-size: small;"> <span>SLV</span> <span>PGV</span> <span>PM SLV</span> <span>PM PGV</span> </div> 0.5 to 20.0 s	5	Available	s	page 7-58
H06	Cooling Fan Function Selection	<div style="display: flex; justify-content: space-between; font-size: small;"> <span>V/f</span> <span>DTV</span> <span>PG V/f</span> <span>PG DTV</span> </div> <div style="display: flex; justify-content: space-between; font-size: small;"> <span>SLV</span> <span>PGV</span> <span>PM SLV</span> <span>PM PGV</span> </div> 0: Always Fan ON 1: ON/OFF control effective	0	Available	-	page 7-99

Parameter No.	Function name	Monitor or Data Range	Default data	Setting during RUN	Unit	Page
H07	Acceleration/Deceleration Pattern Selection	<div style="display: flex; justify-content: space-between; border-bottom: 1px solid black; padding-bottom: 2px;"> <span>V/f</span> <span>DTV</span> <span>PG V/f</span> <span>PG DTV</span> </div> <div style="display: flex; justify-content: space-between; border-bottom: 1px solid black; padding-bottom: 2px;"> <span>SLV</span> <span>PGV</span> <span>PM SLV</span> <span>PM PGV</span> </div> <p>0: Disable (Linear acceleration/deceleration)            1: S-curve acceleration/deceleration (Weak)            2: S-curve acceleration/deceleration (Arbitrary: According to H057 to H060)            3: Curve acceleration/deceleration</p>	0	Available	-	page 5-40
H08	Reverse Rotation Prevention Function	<div style="display: flex; justify-content: space-between; border-bottom: 1px solid black; padding-bottom: 2px;"> <span>V/f</span> <span>DTV</span> <span>PG V/f</span> <span>PG DTV</span> </div> <div style="display: flex; justify-content: space-between; border-bottom: 1px solid black; padding-bottom: 2px;"> <span>SLV</span> <span>PGV</span> <span>PM SLV</span> <span>PM PGV</span> </div> <p>0: Disable            1: Reverse rotation inhibited            2: Forward rotation inhibited</p>	0	-	-	page 7-117
H09	Starting Mode Auto Search Function Selection	<div style="display: flex; justify-content: space-between; border-bottom: 1px solid black; padding-bottom: 2px;"> <span>V/f</span> <span>DTV</span> <span>PG V/f</span> <span>PG DTV</span> </div> <div style="display: flex; justify-content: space-between; border-bottom: 1px solid black; padding-bottom: 2px;"> <span>SLV</span> <span>PGV</span> <span>PM SLV</span> <span>PM PGV</span> </div> <p>0: Disable            1: Enable only at restart after momentary power failure            2: Enable at normal start and restart after momentary power failure</p>	0	-	-	page 7-49
H11	Stop Selection	<div style="display: flex; justify-content: space-between; border-bottom: 1px solid black; padding-bottom: 2px;"> <span>V/f</span> <span>DTV</span> <span>PG V/f</span> <span>PG DTV</span> </div> <div style="display: flex; justify-content: space-between; border-bottom: 1px solid black; padding-bottom: 2px;"> <span>SLV</span> <span>PGV</span> <span>PM SLV</span> <span>PM PGV</span> </div> <p>0: Normal deceleration            1: Free run stop</p>	0	Available	-	page 5-47
H12	Instantaneous Overcurrent Limiting Function Selection	<div style="display: flex; justify-content: space-between; border-bottom: 1px solid black; padding-bottom: 2px;"> <span>V/f</span> <span>DTV</span> <span>PG V/f</span> <span>PG DTV</span> </div> <div style="display: flex; justify-content: space-between; border-bottom: 1px solid black; padding-bottom: 2px;"> <span>SLV</span> <span>PGV</span> <span>PM SLV</span> <span>PM PGV</span> </div> <p>0: Disable            1: Enable</p>	1	Available	-	page 7-87
H13	Power Interruption Restart Wait Time	<div style="display: flex; justify-content: space-between; border-bottom: 1px solid black; padding-bottom: 2px;"> <span>V/f</span> <span>DTV</span> <span>PG V/f</span> <span>PG DTV</span> </div> <div style="display: flex; justify-content: space-between; border-bottom: 1px solid black; padding-bottom: 2px;"> <span>SLV</span> <span>PGV</span> <span>PM SLV</span> <span>PM PGV</span> </div> <p>0.1 to 100.0 s</p>	0.5	Available	s	page 7-49
H14	Deceleration Setting During Current Limit for Restart Mode after Power Interruption	<div style="display: flex; justify-content: space-between; border-bottom: 1px solid black; padding-bottom: 2px;"> <span>V/f</span> <span>DTV</span> <span>PG V/f</span> <span>PG DTV</span> </div> <div style="display: flex; justify-content: space-between; border-bottom: 1px solid black; padding-bottom: 2px;"> <span>SLV</span> <span>PGV</span> <span>PM SLV</span> <span>PM PGV</span> </div> <p>0.00: Selected deceleration time            0.01 to 100.00 Hz/s            999: According to current limiter</p>	32767	Available	Hz/s	page 7-49

Parameter No.	Function name	Monitor or Data Range	Default data	Setting during RUN	Unit	Page
H15	Continuous Running Voltage Level	<div style="display: flex; justify-content: space-between; border-bottom: 1px solid black; padding-bottom: 2px;"> <span>V/f</span> <span>DTV</span> <span>PG V/f</span> <span>PG DTV</span> </div> <div style="display: flex; justify-content: space-between; border-bottom: 1px solid black; padding-bottom: 2px;"> <span>SLV</span> <span>PGV</span> <span>PM SLV</span> <span>PM PGV</span> </div> 200 to 300 V (200 V class series) 400 to 600 V (400 V class series)	235	Available	V	page 7-49
H16	Allowable Time for Power Interruption Restart	<div style="display: flex; justify-content: space-between; border-bottom: 1px solid black; padding-bottom: 2px;"> <span>V/f</span> <span>DTV</span> <span>PG V/f</span> <span>PG DTV</span> </div> <div style="display: flex; justify-content: space-between; border-bottom: 1px solid black; padding-bottom: 2px;"> <span>SLV</span> <span>PGV</span> <span>PM SLV</span> <span>PM PGV</span> </div> 0.0 to 30.0 s 999: Auto judgment	32767	Available	s	page 7-49
H18	Torque Control Operate Selection	<div style="display: flex; justify-content: space-between; border-bottom: 1px solid black; padding-bottom: 2px;"> <span>V/f</span> <span>DTV</span> <span>PG V/f</span> <span>PG DTV</span> </div> <div style="display: flex; justify-content: space-between; border-bottom: 1px solid black; padding-bottom: 2px;"> <span>SLV</span> <span>PGV</span> <span>PM SLV</span> <span>PM PGV</span> </div> 0: Disable (Speed control) 2: Torque current command input 3: Torque command input	0	-	-	page 6-31
H26	Thermistor Function Selection (MOH)	<div style="display: flex; justify-content: space-between; border-bottom: 1px solid black; padding-bottom: 2px;"> <span>V/f</span> <span>DTV</span> <span>PG V/f</span> <span>PG DTV</span> </div> <div style="display: flex; justify-content: space-between; border-bottom: 1px solid black; padding-bottom: 2px;"> <span>SLV</span> <span>PGV</span> <span>PM SLV</span> <span>PM PGV</span> </div> 0: Disable 1: PTC (Inverter immediately trips with OH4 displayed) 2: PTC (Inverter issues output signal MOH and continues to run)	0	Available	-	page 7-88
H27	1st Thermistor Error Detection Level (MOH)	<div style="display: flex; justify-content: space-between; border-bottom: 1px solid black; padding-bottom: 2px;"> <span>V/f</span> <span>DTV</span> <span>PG V/f</span> <span>PG DTV</span> </div> <div style="display: flex; justify-content: space-between; border-bottom: 1px solid black; padding-bottom: 2px;"> <span>SLV</span> <span>PGV</span> <span>PM SLV</span> <span>PM PGV</span> </div> 0.00 to 5.00 V	1.60	Available	V	page 7-88
H28	Droop Control	<div style="display: flex; justify-content: space-between; border-bottom: 1px solid black; padding-bottom: 2px;"> <span>V/f</span> <span>DTV</span> <span>PG V/f</span> <span>PG DTV</span> </div> <div style="display: flex; justify-content: space-between; border-bottom: 1px solid black; padding-bottom: 2px;"> <span>SLV</span> <span>PGV</span> <span>PM SLV</span> <span>PM PGV</span> </div> -60.0 to 0.0 Hz	0	Available	Hz	page 7-149
H42	Main Circuit Capacitor Service Life Coefficient (Measurement Value)	<div style="display: flex; justify-content: space-between; border-bottom: 1px solid black; padding-bottom: 2px;"> <span>V/f</span> <span>DTV</span> <span>PG V/f</span> <span>PG DTV</span> </div> <div style="display: flex; justify-content: space-between; border-bottom: 1px solid black; padding-bottom: 2px;"> <span>SLV</span> <span>PGV</span> <span>PM SLV</span> <span>PM PGV</span> </div> 0: Start measurement 1: Measurement failure 2 to 65535: Measurement value	0	Available	-	page 7-96
H43	Cumulative Run Time of Cooling Fan	<div style="display: flex; justify-content: space-between; border-bottom: 1px solid black; padding-bottom: 2px;"> <span>V/f</span> <span>DTV</span> <span>PG V/f</span> <span>PG DTV</span> </div> <div style="display: flex; justify-content: space-between; border-bottom: 1px solid black; padding-bottom: 2px;"> <span>SLV</span> <span>PGV</span> <span>PM SLV</span> <span>PM PGV</span> </div> 0 to 9,999 (in 10 hours)	0	Available	10 hex	page 7-99
H44	1st Startup Count for Motor	<div style="display: flex; justify-content: space-between; border-bottom: 1px solid black; padding-bottom: 2px;"> <span>V/f</span> <span>DTV</span> <span>PG V/f</span> <span>PG DTV</span> </div> <div style="display: flex; justify-content: space-between; border-bottom: 1px solid black; padding-bottom: 2px;"> <span>SLV</span> <span>PGV</span> <span>PM SLV</span> <span>PM PGV</span> </div> 0 to 65,535	0	Available	-	page 7-93

Parameter No.	Function name	Monitor or Data Range	Default data	Setting during RUN	Unit	Page
H45	Mock Alarm	<input type="checkbox"/> V/f <input type="checkbox"/> DTV <input type="checkbox"/> PG V/f <input type="checkbox"/> PG DTV <input type="checkbox"/> SLV <input type="checkbox"/> PGV <input type="checkbox"/> PM SLV <input type="checkbox"/> PM PGV 0: Disable 1: Enable (Generate mock alarm)	0	Available	-	page 3-3
H46	Auto Search Delay Time 2 for Starting Mode	<input type="checkbox"/> V/f <input type="checkbox"/> DTV <input checked="" type="checkbox"/> PG V/f <input checked="" type="checkbox"/> PG DTV <input type="checkbox"/> SLV <input checked="" type="checkbox"/> PGV <input type="checkbox"/> PM SLV <input type="checkbox"/> PM PGV 0.1 to 100.0 s	1.0	Available	s	page 7-49
H47	Main Circuit Capacitor Service Life Coefficient (Initial Value)	<input type="checkbox"/> V/f <input type="checkbox"/> DTV <input type="checkbox"/> PG V/f <input type="checkbox"/> PG DTV <input type="checkbox"/> SLV <input type="checkbox"/> PGV <input type="checkbox"/> PM SLV <input type="checkbox"/> PM PGV 0: Start measurement 1: Measurement failure 2 to 65535: Measurement value	0	Available	-	page 7-96
H48	Cumulative Run Time of Capacitors on Printed Circuit Boards	<input type="checkbox"/> V/f <input type="checkbox"/> DTV <input type="checkbox"/> PG V/f <input type="checkbox"/> PG DTV <input type="checkbox"/> SLV <input type="checkbox"/> PGV <input type="checkbox"/> PM SLV <input type="checkbox"/> PM PGV 0 to 9,999 (in 10 hours)	0	Available	10 hex	page 7-100
H49	Auto Search Delay Time 1 for Starting Characteristic	<input type="checkbox"/> V/f <input type="checkbox"/> DTV <input type="checkbox"/> PG V/f <input type="checkbox"/> PG DTV <input type="checkbox"/> SLV <input checked="" type="checkbox"/> PGV <input type="checkbox"/> PM SLV <input type="checkbox"/> PM PGV 0.0 to 10.0 s	0	Available	s	page 7-49
H54	Jogging Acceleration Time	<input type="checkbox"/> V/f <input type="checkbox"/> DTV <input type="checkbox"/> PG V/f <input type="checkbox"/> PG DTV <input type="checkbox"/> SLV <input type="checkbox"/> PGV <input type="checkbox"/> PM SLV <input type="checkbox"/> PM PGV 0.00 to 6000 s	6.00	Available	s	page 5-60
H55	Jogging Deceleration Time	<input type="checkbox"/> V/f <input type="checkbox"/> DTV <input type="checkbox"/> PG V/f <input type="checkbox"/> PG DTV <input type="checkbox"/> SLV <input type="checkbox"/> PGV <input type="checkbox"/> PM SLV <input type="checkbox"/> PM PGV 0.00 to 6000 s	6.00	Available	s	page 5-60
H56	Deceleration Time for Forced Stop	<input type="checkbox"/> V/f <input type="checkbox"/> DTV <input type="checkbox"/> PG V/f <input type="checkbox"/> PG DTV <input type="checkbox"/> SLV <input type="checkbox"/> PGV <input type="checkbox"/> PM SLV <input type="checkbox"/> PM PGV 0.00 to 6000 s	6.00	Available	s	page 7-152
H57	S-curve Acceleration Range Frequency at Starting	<input type="checkbox"/> V/f <input type="checkbox"/> DTV <input type="checkbox"/> PG V/f <input type="checkbox"/> PG DTV <input type="checkbox"/> SLV <input type="checkbox"/> PGV <input type="checkbox"/> PM SLV <input type="checkbox"/> PM PGV 0 to 100 %	10	Available	%	page 5-40
H58	S-curve Acceleration Range Frequency at End	<input type="checkbox"/> V/f <input type="checkbox"/> DTV <input type="checkbox"/> PG V/f <input type="checkbox"/> PG DTV <input type="checkbox"/> SLV <input type="checkbox"/> PGV <input type="checkbox"/> PM SLV <input type="checkbox"/> PM PGV 0 to 100 %	10	Available	%	page 5-40
H59	S-curve Deceleration Range Frequency at Starting	<input type="checkbox"/> V/f <input type="checkbox"/> DTV <input type="checkbox"/> PG V/f <input type="checkbox"/> PG DTV <input type="checkbox"/> SLV <input type="checkbox"/> PGV <input type="checkbox"/> PM SLV <input type="checkbox"/> PM PGV 0 to 100 %	10	Available	%	page 5-40

Parameter No.	Function name	Monitor or Data Range	Default data	Setting during RUN	Unit	Page
H60	S-curve Deceleration Range Frequency at End	<div style="display: flex; justify-content: space-between; font-size: small;"> <span>V/f</span> <span>DTV</span> <span>PG V/f</span> <span>PG DTV</span> </div> <div style="display: flex; justify-content: space-between; font-size: small;"> <span>SLV</span> <span>PGV</span> <span>PM SLV</span> <span>PM PGV</span> </div> <p>0 to 100 %</p>	10	Available	%	page 5-40
H61	UP/DOWN Control Initial Value Selection	<div style="display: flex; justify-content: space-between; font-size: small;"> <span>V/f</span> <span>DTV</span> <span>PG V/f</span> <span>PG DTV</span> </div> <div style="display: flex; justify-content: space-between; font-size: small;"> <span>SLV</span> <span>PGV</span> <span>PM SLV</span> <span>PM PGV</span> </div> <p>0: 0.00Hz 1: Last UP/DOWN command value</p>	1	-	-	page 7-119
H63	Frequency Lower Limit Operation Selection	<div style="display: flex; justify-content: space-between; font-size: small;"> <span>V/f</span> <span>DTV</span> <span>PG V/f</span> <span>PG DTV</span> </div> <div style="display: flex; justify-content: space-between; font-size: small;"> <span>SLV</span> <span>PGV</span> <span>PM SLV</span> <span>PM PGV</span> </div> <p>0: Frequency Command is the Frequency Lower Limit. 1: Frequency Command is 0Hz</p>	0	Available	-	page 5-32
H64	Low Frequency during Protecting Overload	<div style="display: flex; justify-content: space-between; font-size: small;"> <span>V/f</span> <span>DTV</span> <span>PG V/f</span> <span>PG DTV</span> </div> <div style="display: flex; justify-content: space-between; font-size: small;"> <span>SLV</span> <span>PGV</span> <span>PM SLV</span> <span>PM PGV</span> </div> <p>0.0: Depends on Frequency Lower Limit(F16) 0.1 to 590.0 Hz</p>	1.6	Available	Hz	page 7-82
H67	Auto Energy Saving Operation Condition Selection	<div style="display: flex; justify-content: space-between; font-size: small;"> <span>V/f</span> <span>DTV</span> <span>PG V/f</span> <span>PG DTV</span> </div> <div style="display: flex; justify-content: space-between; font-size: small;"> <span>SLV</span> <span>PGV</span> <span>PM SLV</span> <span>PM PGV</span> </div> <p>0: Enable only at constant speed 1: Enable in all modes</p>	0	Available	-	page 7-141
H68	1st Slip Compensation Operating Conditions Selection	<div style="display: flex; justify-content: space-between; font-size: small;"> <span>V/f</span> <span>DTV</span> <span>PG V/f</span> <span>PG DTV</span> </div> <div style="display: flex; justify-content: space-between; font-size: small;"> <span>SLV</span> <span>PGV</span> <span>PM SLV</span> <span>PM PGV</span> </div> <p>0: Enable during acceleration/ deceleration, enable at base frequency or higher 1: Disable during acceleration/ deceleration, enable at base frequency or higher 2: Enable during acceleration/ deceleration, disable at base frequency or higher 3: Disable during acceleration/ deceleration, disable at base frequency or higher</p>	0	-	-	page 5-16

Parameter No.	Function name	Monitor or Data Range	Default data	Setting during RUN	Unit	Page
H69	Anti-regenerative Control Function Selection	<div style="display: flex; justify-content: space-between; border-bottom: 1px solid black; padding-bottom: 2px;"> <span>V/f</span> <span>DTV</span> <span>PG V/f</span> <span>PG DTV</span> </div> <div style="display: flex; justify-content: space-between; border-bottom: 1px solid black; padding-bottom: 2px;"> <span>SLV</span> <span>PGV</span> <span>PM SLV</span> <span>PM PGV</span> </div> <p>0: Disable            2: Torque limit control with forced stop after three times deceleration time has passed            3: Main Circuit DC Voltage control with forced stop after three times deceleration time has passed            4: Torque limit control without forced stop            5: Main Circuit DC Voltage control without force-to-stop</p>	0	Available	-	page 7-85
H70	Overload Prevention Control	<div style="display: flex; justify-content: space-between; border-bottom: 1px solid black; padding-bottom: 2px;"> <span>V/f</span> <span>DTV</span> <span>PG V/f</span> <span>PG DTV</span> </div> <div style="display: flex; justify-content: space-between; border-bottom: 1px solid black; padding-bottom: 2px;"> <span>SLV</span> <span>PGV</span> <span>PM SLV</span> <span>PM PGV</span> </div> <p>0.00: Depend on selected deceleration time            0.01 to 100.00 Hz/s            999: Cancel</p>	32767	Available	Hz/s	page 7-82
H71	Over-Excitation Control Selection during Deceleration Function Selection	<div style="display: flex; justify-content: space-between; border-bottom: 1px solid black; padding-bottom: 2px;"> <span>V/f</span> <span>DTV</span> <span>PG V/f</span> <span>PG DTV</span> </div> <div style="display: flex; justify-content: space-between; border-bottom: 1px solid black; padding-bottom: 2px;"> <span>SLV</span> <span>PGV</span> <span>PM SLV</span> <span>PM PGV</span> </div> <p>0: Disable            1: Enable</p>	0	Available	-	page 7-121
H72	Do not use	-	-	-	-	-
H74	Torque Limit Function Selection	<div style="display: flex; justify-content: space-between; border-bottom: 1px solid black; padding-bottom: 2px;"> <span>V/f</span> <span>DTV</span> <span>PG V/f</span> <span>PG DTV</span> </div> <div style="display: flex; justify-content: space-between; border-bottom: 1px solid black; padding-bottom: 2px;"> <span>SLV</span> <span>PGV</span> <span>PM SLV</span> <span>PM PGV</span> </div> <p>0: Torque limit            1: Torque current limit</p>	1	-	-	page 6-81
H75	Torque Limit Operation Selection	<div style="display: flex; justify-content: space-between; border-bottom: 1px solid black; padding-bottom: 2px;"> <span>V/f</span> <span>DTV</span> <span>PG V/f</span> <span>PG DTV</span> </div> <div style="display: flex; justify-content: space-between; border-bottom: 1px solid black; padding-bottom: 2px;"> <span>SLV</span> <span>PGV</span> <span>PM SLV</span> <span>PM PGV</span> </div> <p>0: Four quadrants independent            1: Four quadrants identical</p>	0	-	-	page 6-81
H76	Frequency Rising Limit for Torque Limit	<div style="display: flex; justify-content: space-between; border-bottom: 1px solid black; padding-bottom: 2px;"> <span>V/f</span> <span>DTV</span> <span>PG V/f</span> <span>PG DTV</span> </div> <div style="display: flex; justify-content: space-between; border-bottom: 1px solid black; padding-bottom: 2px;"> <span>SLV</span> <span>PGV</span> <span>PM SLV</span> <span>PM PGV</span> </div> <p>0.0 to 590.0 Hz</p>	5	Available	Hz	page 6-81
H77	Service Life of Main Circuit Capacitor Remaining Time	<div style="display: flex; justify-content: space-between; border-bottom: 1px solid black; padding-bottom: 2px;"> <span>V/f</span> <span>DTV</span> <span>PG V/f</span> <span>PG DTV</span> </div> <div style="display: flex; justify-content: space-between; border-bottom: 1px solid black; padding-bottom: 2px;"> <span>SLV</span> <span>PGV</span> <span>PM SLV</span> <span>PM PGV</span> </div> <p>0 to 8760 (in 10 hours)</p>	8760	Available	10 hex	page 7-96
H78	1st Motor Maintenance Interval	<div style="display: flex; justify-content: space-between; border-bottom: 1px solid black; padding-bottom: 2px;"> <span>V/f</span> <span>DTV</span> <span>PG V/f</span> <span>PG DTV</span> </div> <div style="display: flex; justify-content: space-between; border-bottom: 1px solid black; padding-bottom: 2px;"> <span>SLV</span> <span>PGV</span> <span>PM SLV</span> <span>PM PGV</span> </div> <p>0: Disable            1 to 9999 (in 10 hours)</p>	8760	Available	10 hex	page 7-93

Parameter No.	Function name	Monitor or Data Range	Default data	Setting during RUN	Unit	Page
H79	1st Preset Startup Count for Motor Maintenance	<input type="checkbox"/> V/f <input type="checkbox"/> DTV <input type="checkbox"/> PG V/f <input type="checkbox"/> PG DTV <input type="checkbox"/> SLV <input type="checkbox"/> PGV <input type="checkbox"/> PM SLV <input type="checkbox"/> PM PGV 0: Disable 1 to 65,535	0	Available	-	page 7-93
H80	1st Output Current Fluctuation Damping Gain	<input type="checkbox"/> V/f <input type="checkbox"/> DTV <input type="checkbox"/> PG V/f <input type="checkbox"/> PG DTV <input checked="" type="checkbox"/> SLV <input checked="" type="checkbox"/> PGV <input checked="" type="checkbox"/> PM SLV <input checked="" type="checkbox"/> PM PGV 0.00 to 1.00	0.20	Available	-	page 7-144
H81	Light Alarm Selection 1	<input type="checkbox"/> V/f <input type="checkbox"/> DTV <input type="checkbox"/> PG V/f <input type="checkbox"/> PG DTV <input type="checkbox"/> SLV <input type="checkbox"/> PGV <input type="checkbox"/> PM SLV <input type="checkbox"/> PM PGV 0000 to FFFF Hex	0	Available	-	page 7-108
H82	Light Alarm Selection 2	<input type="checkbox"/> V/f <input type="checkbox"/> DTV <input type="checkbox"/> PG V/f <input type="checkbox"/> PG DTV <input type="checkbox"/> SLV <input type="checkbox"/> PGV <input type="checkbox"/> PM SLV <input type="checkbox"/> PM PGV 0000 to FFFF Hex	0	Available	-	page 7-108
H84	Pre-excitation Level	<input type="checkbox"/> V/f <input type="checkbox"/> DTV <input type="checkbox"/> PG V/f <input type="checkbox"/> PG DTV <input type="checkbox"/> SLV <input type="checkbox"/> PGV <input checked="" type="checkbox"/> PM SLV <input checked="" type="checkbox"/> PM PGV 100 to 400 %	100	Available	%	page 7-151
H85	Pre-excitation Timer	<input type="checkbox"/> V/f <input type="checkbox"/> DTV <input type="checkbox"/> PG V/f <input type="checkbox"/> PG DTV <input type="checkbox"/> SLV <input type="checkbox"/> PGV <input checked="" type="checkbox"/> PM SLV <input checked="" type="checkbox"/> PM PGV 0.00: Disable 0.01 to 30.00 s	0.00	Available	s	page 7-151
H86	Do not use	-	-	-	-	-
H89	Motor Electronic Thermal Overload Protection Data Retention	<input type="checkbox"/> V/f <input type="checkbox"/> DTV <input type="checkbox"/> PG V/f <input type="checkbox"/> PG DTV <input type="checkbox"/> SLV <input type="checkbox"/> PGV <input type="checkbox"/> PM SLV <input type="checkbox"/> PM PGV 0: Disable 1: Enable	1	Available	-	page 5-20
H90	Do not use	-	-	-	-	-
H91	Current Input Wire Break Detection	<input type="checkbox"/> V/f <input type="checkbox"/> DTV <input type="checkbox"/> PG V/f <input type="checkbox"/> PG DTV <input type="checkbox"/> SLV <input type="checkbox"/> PGV <input type="checkbox"/> PM SLV <input type="checkbox"/> PM PGV 0.0: Disable alarm detection 0.1 to 60.0 s: Issue alarm after set time	0	Available	s	page 7-123
H92	Continuous Running at the Momentary Power Failure P Proportional Gain	<input type="checkbox"/> V/f <input type="checkbox"/> DTV <input type="checkbox"/> PG V/f <input type="checkbox"/> PG DTV <input type="checkbox"/> SLV <input type="checkbox"/> PGV <input type="checkbox"/> PM SLV <input type="checkbox"/> PM PGV 0.000 to 10.000 999: Auto	32767	Available	-	page 7-49
H93	Continuous Running at the Momentary Power Failure Integral Time	<input type="checkbox"/> V/f <input type="checkbox"/> DTV <input type="checkbox"/> PG V/f <input type="checkbox"/> PG DTV <input type="checkbox"/> SLV <input type="checkbox"/> PGV <input type="checkbox"/> PM SLV <input type="checkbox"/> PM PGV 0.010 to 10.000 s 999: Auto	32767	Available	s	page 7-49



Parameter No.	Function name	Monitor or Data Range	Default data	Setting during RUN	Unit	Page
H94	1st Cumulative Motor Run Time	<div style="display: flex; justify-content: space-between; border: 1px solid black; padding: 2px;"> <span>V/f</span> <span>DTV</span> <span>PG V/f</span> <span>PG DTV</span> </div> <div style="display: flex; justify-content: space-between; border: 1px solid black; padding: 2px;"> <span>SLV</span> <span>PGV</span> <span>PM SLV</span> <span>PM PGV</span> </div> 0 to 9,999 (in 10 hours)	0	-	10 hex	page 7-93
H95	DC Injection Braking Start Characteristic Selection	<div style="display: flex; justify-content: space-between; border: 1px solid black; padding: 2px;"> <span>V/f</span> <span>DTV</span> <span>PG V/f</span> <span>PG DTV</span> </div> <div style="display: flex; justify-content: space-between; border: 1px solid black; padding: 2px;"> <span>SLV</span> <span>PGV</span> <span>PM SLV</span> <span>PM PGV</span> </div> 0: Slow response 1: Quick response	1	Available	-	page 7-63
H96	STOP Key Priority/ Start Check Function	<div style="display: flex; justify-content: space-between; border: 1px solid black; padding: 2px;"> <span>V/f</span> <span>DTV</span> <span>PG V/f</span> <span>PG DTV</span> </div> <div style="display: flex; justify-content: space-between; border: 1px solid black; padding: 2px;"> <span>SLV</span> <span>PGV</span> <span>PM SLV</span> <span>PM PGV</span> </div> 0: Disable STOP key priority, disable start check function 1: Enable STOP key priority, disable start check function 2: Disable STOP key priority, enable start check function 3: Enable STOP key priority, enable start check function	0	Available	-	page 7-80
H98	Protection/Maintenance Function Mode Selection	<div style="display: flex; justify-content: space-between; border: 1px solid black; padding: 2px;"> <span>V/f</span> <span>DTV</span> <span>PG V/f</span> <span>PG DTV</span> </div> <div style="display: flex; justify-content: space-between; border: 1px solid black; padding: 2px;"> <span>SLV</span> <span>PGV</span> <span>PM SLV</span> <span>PM PGV</span> </div> Bit7: Reserved Bit6: Braking transistor error detection 0: Disable 1: Enable Bit5: Detect charge register overheat 0: Enable 1: Disable Bit4: Judge main circuit capacitor life 0: Disable 1: Enable Bit3: Main circuit capacitor life judgment selection 0: Factory default standard 1: User measurement value standard Bit0 to 2: Reserved	80	Available	-	page 7-157
H99	Password 2 Setting/ Verification	<div style="display: flex; justify-content: space-between; border: 1px solid black; padding: 2px;"> <span>V/f</span> <span>DTV</span> <span>PG V/f</span> <span>PG DTV</span> </div> <div style="display: flex; justify-content: space-between; border: 1px solid black; padding: 2px;"> <span>SLV</span> <span>PGV</span> <span>PM SLV</span> <span>PM PGV</span> </div> 0000 to FFFF Hex	0	Available	-	page 7-77
H114	Anti-regenerative Control Level	<div style="display: flex; justify-content: space-between; border: 1px solid black; padding: 2px;"> <span>V/f</span> <span>DTV</span> <span>PG V/f</span> <span>PG DTV</span> </div> <div style="display: flex; justify-content: space-between; border: 1px solid black; padding: 2px;"> <span>SLV</span> <span>PGV</span> <span>PM SLV</span> <span>PM PGV</span> </div> 0.0 to 50.0 % 999: Auto	32767	Available	%	page 7-85
H130	Do not use	-	-	-	-	-

Parameter No.	Function name	Monitor or Data Range	Default data	Setting during RUN	Unit	Page
H131	Do not use	-	-	-	-	-
H133	Do not use	-	-	-	-	-
H134	Do not use	-	-	-	-	-
H147	Speed Control Jogging Feed Forward Gain	<div style="display: flex; justify-content: space-between; border-bottom: 1px solid black; padding-bottom: 2px;"> <span>V/f</span> <span>DTV</span> <span>PG V/f</span> <span>PG DTV</span> </div> <div style="display: flex; justify-content: space-between; border-bottom: 1px solid black; padding-bottom: 2px;"> <span>SLV</span> <span>PGV</span> <span>PM SLV</span> <span>PM PGV</span> </div> 0.00 to 99.99 s	0	Available	s	page 5-60
H154	Torque Bias Function Selection	<div style="display: flex; justify-content: space-between; border-bottom: 1px solid black; padding-bottom: 2px;"> <span>V/f</span> <span>DTV</span> <span>PG V/f</span> <span>PG DTV</span> </div> <div style="display: flex; justify-content: space-between; border-bottom: 1px solid black; padding-bottom: 2px;"> <span>SLV</span> <span>PGV</span> <span>PM SLV</span> <span>PM PGV</span> </div> 0: Invalid 1: Operator (H155 to H157) 2: Analog input 4: RS-485 communication 5: Fieldbus (Reserved)	0	-	-	page 6-33
H155	Torque Bias Level 1	<div style="display: flex; justify-content: space-between; border-bottom: 1px solid black; padding-bottom: 2px;"> <span>V/f</span> <span>DTV</span> <span>PG V/f</span> <span>PG DTV</span> </div> <div style="display: flex; justify-content: space-between; border-bottom: 1px solid black; padding-bottom: 2px;"> <span>SLV</span> <span>PGV</span> <span>PM SLV</span> <span>PM PGV</span> </div> -300 to +300 %	0	Available	%	page 6-33
H156	Torque Bias Level 2	<div style="display: flex; justify-content: space-between; border-bottom: 1px solid black; padding-bottom: 2px;"> <span>V/f</span> <span>DTV</span> <span>PG V/f</span> <span>PG DTV</span> </div> <div style="display: flex; justify-content: space-between; border-bottom: 1px solid black; padding-bottom: 2px;"> <span>SLV</span> <span>PGV</span> <span>PM SLV</span> <span>PM PGV</span> </div> -300 to +300 %	0	Available	%	page 6-33
H157	Torque Bias Level 3	<div style="display: flex; justify-content: space-between; border-bottom: 1px solid black; padding-bottom: 2px;"> <span>V/f</span> <span>DTV</span> <span>PG V/f</span> <span>PG DTV</span> </div> <div style="display: flex; justify-content: space-between; border-bottom: 1px solid black; padding-bottom: 2px;"> <span>SLV</span> <span>PGV</span> <span>PM SLV</span> <span>PM PGV</span> </div> -300 to +300 %	0	Available	%	page 6-33
H158	Torque Bias Mechanical Loss Compensation	<div style="display: flex; justify-content: space-between; border-bottom: 1px solid black; padding-bottom: 2px;"> <span>V/f</span> <span>DTV</span> <span>PG V/f</span> <span>PG DTV</span> </div> <div style="display: flex; justify-content: space-between; border-bottom: 1px solid black; padding-bottom: 2px;"> <span>SLV</span> <span>PGV</span> <span>PM SLV</span> <span>PM PGV</span> </div> 0 to 300 %	0	Available	%	page 6-33
H159	Torque Bias Startup Timer	<div style="display: flex; justify-content: space-between; border-bottom: 1px solid black; padding-bottom: 2px;"> <span>V/f</span> <span>DTV</span> <span>PG V/f</span> <span>PG DTV</span> </div> <div style="display: flex; justify-content: space-between; border-bottom: 1px solid black; padding-bottom: 2px;"> <span>SLV</span> <span>PGV</span> <span>PM SLV</span> <span>PM PGV</span> </div> 0.00 to 1.00 s	0	-	s	page 6-33
H161	Torque Bias Shutdown Timer	<div style="display: flex; justify-content: space-between; border-bottom: 1px solid black; padding-bottom: 2px;"> <span>V/f</span> <span>DTV</span> <span>PG V/f</span> <span>PG DTV</span> </div> <div style="display: flex; justify-content: space-between; border-bottom: 1px solid black; padding-bottom: 2px;"> <span>SLV</span> <span>PGV</span> <span>PM SLV</span> <span>PM PGV</span> </div> 0.00 to 1.00 s	0	-	s	page 6-33
H162	Torque Bias Limit	<div style="display: flex; justify-content: space-between; border-bottom: 1px solid black; padding-bottom: 2px;"> <span>V/f</span> <span>DTV</span> <span>PG V/f</span> <span>PG DTV</span> </div> <div style="display: flex; justify-content: space-between; border-bottom: 1px solid black; padding-bottom: 2px;"> <span>SLV</span> <span>PGV</span> <span>PM SLV</span> <span>PM PGV</span> </div> 0 to 300 %	200	-	%	page 6-33
H173	Magnetic Flux Level at Light Load	<div style="display: flex; justify-content: space-between; border-bottom: 1px solid black; padding-bottom: 2px;"> <span>V/f</span> <span>DTV</span> <span>PG V/f</span> <span>PG DTV</span> </div> <div style="display: flex; justify-content: space-between; border-bottom: 1px solid black; padding-bottom: 2px;"> <span>SLV</span> <span>PGV</span> <span>PM SLV</span> <span>PM PGV</span> </div> 10 to 100%	100	Available	%	page 7-150
H180	Brake Error Detection Time	<div style="display: flex; justify-content: space-between; border-bottom: 1px solid black; padding-bottom: 2px;"> <span>V/f</span> <span>DTV</span> <span>PG V/f</span> <span>PG DTV</span> </div> <div style="display: flex; justify-content: space-between; border-bottom: 1px solid black; padding-bottom: 2px;"> <span>SLV</span> <span>PGV</span> <span>PM SLV</span> <span>PM PGV</span> </div> 0.00 to 10.00 s	1.00	Available	s	page 6-76

Parameter No.	Function name	Monitor or Data Range	Default data	Setting during RUN	Unit	Page
H185	Do not use	-	-	-	-	-
H193	User Preference Data-set Registration	<div style="display: flex; justify-content: space-between; border: 1px solid black; padding: 2px;"> <span>V/f</span> <span>DTV</span> <span>PG V/f</span> <span>PG DTV</span> </div> <div style="display: flex; justify-content: space-between; border: 1px solid black; padding: 2px;"> <span>SLV</span> <span>PGV</span> <span>PM SLV</span> <span>PM PGV</span> </div> 0: Disable 1: Store	0	-	-	page 5-4
H194	User Preference Data-set Protection Function Selection	<div style="display: flex; justify-content: space-between; border: 1px solid black; padding: 2px;"> <span>V/f</span> <span>DTV</span> <span>PG V/f</span> <span>PG DTV</span> </div> <div style="display: flex; justify-content: space-between; border: 1px solid black; padding: 2px;"> <span>SLV</span> <span>PGV</span> <span>PM SLV</span> <span>PM PGV</span> </div> 0: Unprotected 1: Protected	0	Available	-	page 5-4
H195	DC Injection Braking Startup Time	<div style="display: flex; justify-content: space-between; border: 1px solid black; padding: 2px;"> <span>V/f</span> <span>DTV</span> <span>PG V/f</span> <span>PG DTV</span> </div> <div style="display: flex; justify-content: space-between; border: 1px solid black; padding: 2px;"> <span>SLV</span> <span>PGV</span> <span>PM SLV</span> <span>PM PGV</span> </div> 0.00: Disable 0.01 to 30.00 s Only motor 1 is effective	0	Available	s	page 7-63
H196	Do not use	-	-	-	-	-
H197	User password 1 Mode selection	<div style="display: flex; justify-content: space-between; border: 1px solid black; padding: 2px;"> <span>V/f</span> <span>DTV</span> <span>PG V/f</span> <span>PG DTV</span> </div> <div style="display: flex; justify-content: space-between; border: 1px solid black; padding: 2px;"> <span>SLV</span> <span>PGV</span> <span>PM SLV</span> <span>PM PGV</span> </div> 0: Display all, but prevent changes 1: Display and allow changes in quick-setup only 2: Do not use	0	Available	-	page 7-77
H198	User Password 1 Setting/Verification	<div style="display: flex; justify-content: space-between; border: 1px solid black; padding: 2px;"> <span>V/f</span> <span>DTV</span> <span>PG V/f</span> <span>PG DTV</span> </div> <div style="display: flex; justify-content: space-between; border: 1px solid black; padding: 2px;"> <span>SLV</span> <span>PGV</span> <span>PM SLV</span> <span>PM PGV</span> </div> 0000 to FFFF Hex	0	Available	-	page 7-77
H199	User Password 1 Setting	<div style="display: flex; justify-content: space-between; border: 1px solid black; padding: 2px;"> <span>V/f</span> <span>DTV</span> <span>PG V/f</span> <span>PG DTV</span> </div> <div style="display: flex; justify-content: space-between; border: 1px solid black; padding: 2px;"> <span>SLV</span> <span>PGV</span> <span>PM SLV</span> <span>PM PGV</span> </div> 0: Disable 1: Protected	0	Available	-	page 7-77
H303	Co-Inverter Communication Function Selection	<div style="display: flex; justify-content: space-between; border: 1px solid black; padding: 2px;"> <span>V/f</span> <span>DTV</span> <span>PG V/f</span> <span>PG DTV</span> </div> <div style="display: flex; justify-content: space-between; border: 1px solid black; padding: 2px;"> <span>SLV</span> <span>PGV</span> <span>PM SLV</span> <span>PM PGV</span> </div> 0: Disable 1: Enable 2: Enable (administrator)	0	-	-	page 8-28
H304	Co-inverter Communication Starting Station Number (Administrator)	<div style="display: flex; justify-content: space-between; border: 1px solid black; padding: 2px;"> <span>V/f</span> <span>DTV</span> <span>PG V/f</span> <span>PG DTV</span> </div> <div style="display: flex; justify-content: space-between; border: 1px solid black; padding: 2px;"> <span>SLV</span> <span>PGV</span> <span>PM SLV</span> <span>PM PGV</span> </div> 1 to 8 Need to be set in administrator(H303=2)	1	-	-	page 8-28

Parameter No.	Function name	Monitor or Data Range	Default data	Setting during RUN	Unit	Page
H305	Co-inverter Communication Ending Station Number (Administrator)	<div style="display: flex; justify-content: space-between; border-bottom: 1px solid black; padding-bottom: 2px;"> <span>V/f</span> <span>DTV</span> <span>PG V/f</span> <span>PG DTV</span> </div> <div style="display: flex; justify-content: space-between; border-bottom: 1px solid black; padding-bottom: 2px;"> <span>SLV</span> <span>PGV</span> <span>PM SLV</span> <span>PM PGV</span> </div> 1 to 8 Need to be set in administrator(H303=2)	1	-	-	page 8-28
H306	Co-inverter Communication Start Selection (Administrator)	<div style="display: flex; justify-content: space-between; border-bottom: 1px solid black; padding-bottom: 2px;"> <span>V/f</span> <span>DTV</span> <span>PG V/f</span> <span>PG DTV</span> </div> <div style="display: flex; justify-content: space-between; border-bottom: 1px solid black; padding-bottom: 2px;"> <span>SLV</span> <span>PGV</span> <span>PM SLV</span> <span>PM PGV</span> </div> 0: Input terminal[DI1] to [DI8] Co-inverter communication start (485) 1: Always ON Need to be set in administrator(H303=2)	0	-	-	page 8-28
H309	Output Terminal [DO1] ON Delay Time	<div style="display: flex; justify-content: space-between; border-bottom: 1px solid black; padding-bottom: 2px;"> <span>V/f</span> <span>DTV</span> <span>PG V/f</span> <span>PG DTV</span> </div> <div style="display: flex; justify-content: space-between; border-bottom: 1px solid black; padding-bottom: 2px;"> <span>SLV</span> <span>PGV</span> <span>PM SLV</span> <span>PM PGV</span> </div> 0.0 to 100.0 s	0.00	-	s	page 5-67
H310	Output Terminal[DO1] OFF Delay Time	<div style="display: flex; justify-content: space-between; border-bottom: 1px solid black; padding-bottom: 2px;"> <span>V/f</span> <span>DTV</span> <span>PG V/f</span> <span>PG DTV</span> </div> <div style="display: flex; justify-content: space-between; border-bottom: 1px solid black; padding-bottom: 2px;"> <span>SLV</span> <span>PGV</span> <span>PM SLV</span> <span>PM PGV</span> </div> 0.0 to 100.0 s	0.00	-	s	page 5-67
H311	Output Terminal[DO2] ON Delay Time	<div style="display: flex; justify-content: space-between; border-bottom: 1px solid black; padding-bottom: 2px;"> <span>V/f</span> <span>DTV</span> <span>PG V/f</span> <span>PG DTV</span> </div> <div style="display: flex; justify-content: space-between; border-bottom: 1px solid black; padding-bottom: 2px;"> <span>SLV</span> <span>PGV</span> <span>PM SLV</span> <span>PM PGV</span> </div> 0.0 to 100.0 s	0.00	-	s	page 5-67
H312	Output Terminal[DO2] OFF Delay Time	<div style="display: flex; justify-content: space-between; border-bottom: 1px solid black; padding-bottom: 2px;"> <span>V/f</span> <span>DTV</span> <span>PG V/f</span> <span>PG DTV</span> </div> <div style="display: flex; justify-content: space-between; border-bottom: 1px solid black; padding-bottom: 2px;"> <span>SLV</span> <span>PGV</span> <span>PM SLV</span> <span>PM PGV</span> </div> 0.0 to 100.0 s	0.00	-	s	page 5-67
H313	Output Terminal [ROA, ROB] ON Delay Time	<div style="display: flex; justify-content: space-between; border-bottom: 1px solid black; padding-bottom: 2px;"> <span>V/f</span> <span>DTV</span> <span>PG V/f</span> <span>PG DTV</span> </div> <div style="display: flex; justify-content: space-between; border-bottom: 1px solid black; padding-bottom: 2px;"> <span>SLV</span> <span>PGV</span> <span>PM SLV</span> <span>PM PGV</span> </div> 0.0 to 100.0 s	0.00	-	s	page 5-67
H314	Output Terminal [ROA, ROB] OFF Delay Time	<div style="display: flex; justify-content: space-between; border-bottom: 1px solid black; padding-bottom: 2px;"> <span>V/f</span> <span>DTV</span> <span>PG V/f</span> <span>PG DTV</span> </div> <div style="display: flex; justify-content: space-between; border-bottom: 1px solid black; padding-bottom: 2px;"> <span>SLV</span> <span>PGV</span> <span>PM SLV</span> <span>PM PGV</span> </div> 0.0 to 100.0 s	0.00	-	s	page 5-67
H315	Logical Expression 1 Operation Target 1	<div style="display: flex; justify-content: space-between; border-bottom: 1px solid black; padding-bottom: 2px;"> <span>V/f</span> <span>DTV</span> <span>PG V/f</span> <span>PG DTV</span> </div> <div style="display: flex; justify-content: space-between; border-bottom: 1px solid black; padding-bottom: 2px;"> <span>SLV</span> <span>PGV</span> <span>PM SLV</span> <span>PM PGV</span> </div> Refer to other sheet 27,100,206,207,208 Can't be selected	0	-	-	page 7-94
H316	Logical Expression 1 Operation Target 2	<div style="display: flex; justify-content: space-between; border-bottom: 1px solid black; padding-bottom: 2px;"> <span>V/f</span> <span>DTV</span> <span>PG V/f</span> <span>PG DTV</span> </div> <div style="display: flex; justify-content: space-between; border-bottom: 1px solid black; padding-bottom: 2px;"> <span>SLV</span> <span>PGV</span> <span>PM SLV</span> <span>PM PGV</span> </div> Refer to other sheet 27,100,206,207,208 Can't be selected	0	-	-	page 7-94

Parameter No.	Function name	Monitor or Data Range	Default data	Setting during RUN	Unit	Page
H317	Logical Expression 1 Logical Operator	<input type="checkbox"/> V/f <input type="checkbox"/> DTV <input type="checkbox"/> PG V/f <input type="checkbox"/> PG DTV <input type="checkbox"/> SLV <input type="checkbox"/> PGV <input type="checkbox"/> PM SLV <input type="checkbox"/> PM PGV 0: AND 1: OR 2: XOR	0	-	-	page 7-94
H318	Logical Expression 2 Operation Target 1	<input type="checkbox"/> V/f <input type="checkbox"/> DTV <input type="checkbox"/> PG V/f <input type="checkbox"/> PG DTV <input type="checkbox"/> SLV <input type="checkbox"/> PGV <input type="checkbox"/> PM SLV <input type="checkbox"/> PM PGV Refer to other sheet 27,100,206,207,208 Can't be selected	0	-	-	page 7-94
H319	Logical Expression 2 Operation Target 2	<input type="checkbox"/> V/f <input type="checkbox"/> DTV <input type="checkbox"/> PG V/f <input type="checkbox"/> PG DTV <input type="checkbox"/> SLV <input type="checkbox"/> PGV <input type="checkbox"/> PM SLV <input type="checkbox"/> PM PGV Refer to other sheet 27,100,206,207,208 Can't be selected	0	-	-	page 7-94
H320	Logical Expression 2 Logical Operator	<input type="checkbox"/> V/f <input type="checkbox"/> DTV <input type="checkbox"/> PG V/f <input type="checkbox"/> PG DTV <input type="checkbox"/> SLV <input type="checkbox"/> PGV <input type="checkbox"/> PM SLV <input type="checkbox"/> PM PGV 0: AND 1: OR 2: XOR	0	-	-	page 7-94
H321	Logical Expression 3 Operation Target 1	<input type="checkbox"/> V/f <input type="checkbox"/> DTV <input type="checkbox"/> PG V/f <input type="checkbox"/> PG DTV <input type="checkbox"/> SLV <input type="checkbox"/> PGV <input type="checkbox"/> PM SLV <input type="checkbox"/> PM PGV Refer to other sheet 27,100,206,207,208 Can't be selected	0	-	-	page 7-94
H322	Logical Expression 3 Operation Target 2	<input type="checkbox"/> V/f <input type="checkbox"/> DTV <input type="checkbox"/> PG V/f <input type="checkbox"/> PG DTV <input type="checkbox"/> SLV <input type="checkbox"/> PGV <input type="checkbox"/> PM SLV <input type="checkbox"/> PM PGV Refer to other sheet 27,100,206,207,208 Can't be selected	0	-	-	page 7-94
H323	Logical Expression 3 Logical Operator	<input type="checkbox"/> V/f <input type="checkbox"/> DTV <input type="checkbox"/> PG V/f <input type="checkbox"/> PG DTV <input type="checkbox"/> SLV <input type="checkbox"/> PGV <input type="checkbox"/> PM SLV <input type="checkbox"/> PM PGV 0: AND 1: OR 2: XOR	0	-	-	page 7-94
H324	Input Terminal [DI1] Response Time	<input type="checkbox"/> V/f <input type="checkbox"/> DTV <input type="checkbox"/> PG V/f <input type="checkbox"/> PG DTV <input type="checkbox"/> SLV <input type="checkbox"/> PGV <input type="checkbox"/> PM SLV <input type="checkbox"/> PM PGV 1 to 400 ms	1	-	ms	page 5-51
H325	Input Terminal [DI2] Response Time	<input type="checkbox"/> V/f <input type="checkbox"/> DTV <input type="checkbox"/> PG V/f <input type="checkbox"/> PG DTV <input type="checkbox"/> SLV <input type="checkbox"/> PGV <input type="checkbox"/> PM SLV <input type="checkbox"/> PM PGV 1 to 400 ms	1	-	ms	page 5-51

Parameter No.	Function name	Monitor or Data Range	Default data	Setting during RUN	Unit	Page
H326	Input Terminal [DI3] Response Time	<div style="display: flex; justify-content: space-between; border-bottom: 1px solid black; padding-bottom: 2px;"> <span>V/f</span> <span>DTV</span> <span>PG V/f</span> <span>PG DTV</span> </div> <div style="display: flex; justify-content: space-between; border-bottom: 1px solid black; padding-bottom: 2px;"> <span>SLV</span> <span>PGV</span> <span>PM SLV</span> <span>PM PGV</span> </div> 1 to 400 ms	1	-	ms	page 5-51
H327	Input Terminal [DI4] Response Time	<div style="display: flex; justify-content: space-between; border-bottom: 1px solid black; padding-bottom: 2px;"> <span>V/f</span> <span>DTV</span> <span>PG V/f</span> <span>PG DTV</span> </div> <div style="display: flex; justify-content: space-between; border-bottom: 1px solid black; padding-bottom: 2px;"> <span>SLV</span> <span>PGV</span> <span>PM SLV</span> <span>PM PGV</span> </div> 1 to 400 ms	1	-	ms	page 5-51
H328	Input Terminal [DI5] Response Time	<div style="display: flex; justify-content: space-between; border-bottom: 1px solid black; padding-bottom: 2px;"> <span>V/f</span> <span>DTV</span> <span>PG V/f</span> <span>PG DTV</span> </div> <div style="display: flex; justify-content: space-between; border-bottom: 1px solid black; padding-bottom: 2px;"> <span>SLV</span> <span>PGV</span> <span>PM SLV</span> <span>PM PGV</span> </div> 1 to 400 ms	1	-	ms	page 5-51
H329	Input Terminal [DI6] Response Time	<div style="display: flex; justify-content: space-between; border-bottom: 1px solid black; padding-bottom: 2px;"> <span>V/f</span> <span>DTV</span> <span>PG V/f</span> <span>PG DTV</span> </div> <div style="display: flex; justify-content: space-between; border-bottom: 1px solid black; padding-bottom: 2px;"> <span>SLV</span> <span>PGV</span> <span>PM SLV</span> <span>PM PGV</span> </div> 1 to 400 ms	1	-	ms	page 5-51
H330	Input Terminal [DI7] Response Time	<div style="display: flex; justify-content: space-between; border-bottom: 1px solid black; padding-bottom: 2px;"> <span>V/f</span> <span>DTV</span> <span>PG V/f</span> <span>PG DTV</span> </div> <div style="display: flex; justify-content: space-between; border-bottom: 1px solid black; padding-bottom: 2px;"> <span>SLV</span> <span>PGV</span> <span>PM SLV</span> <span>PM PGV</span> </div> 1 to 400 ms	1	-	ms	page 5-51
H332	Torque Reference Selection	<div style="display: flex; justify-content: space-between; border-bottom: 1px solid black; padding-bottom: 2px;"> <span>V/f</span> <span>DTV</span> <span>PG V/f</span> <span>PG DTV</span> </div> <div style="display: flex; justify-content: space-between; border-bottom: 1px solid black; padding-bottom: 2px;"> <span>SLV</span> <span>PGV</span> <span>PM SLV</span> <span>PM PGV</span> </div> 0: Analog input 2: Operator (H333) 4: RS-485 communication 5: Fieldbus (Reserved)	0	-	-	page 6-31
H333	Torque Reference	<div style="display: flex; justify-content: space-between; border-bottom: 1px solid black; padding-bottom: 2px;"> <span>V/f</span> <span>DTV</span> <span>PG V/f</span> <span>PG DTV</span> </div> <div style="display: flex; justify-content: space-between; border-bottom: 1px solid black; padding-bottom: 2px;"> <span>SLV</span> <span>PGV</span> <span>PM SLV</span> <span>PM PGV</span> </div> 0 to 200 %	0	Available	%	page 6-31
H334	Torque Bias Polarity Selection	<div style="display: flex; justify-content: space-between; border-bottom: 1px solid black; padding-bottom: 2px;"> <span>V/f</span> <span>DTV</span> <span>PG V/f</span> <span>PG DTV</span> </div> <div style="display: flex; justify-content: space-between; border-bottom: 1px solid black; padding-bottom: 2px;"> <span>SLV</span> <span>PGV</span> <span>PM SLV</span> <span>PM PGV</span> </div> 0: As signed 1: Depend on run direction	0	-	-	page 6-33
H339	Number of Sent Data of All Stations in Co-inverter Communication	<div style="display: flex; justify-content: space-between; border-bottom: 1px solid black; padding-bottom: 2px;"> <span>V/f</span> <span>DTV</span> <span>PG V/f</span> <span>PG DTV</span> </div> <div style="display: flex; justify-content: space-between; border-bottom: 1px solid black; padding-bottom: 2px;"> <span>SLV</span> <span>PGV</span> <span>PM SLV</span> <span>PM PGV</span> </div> 1 to 5	5	Available	-	page 8-28
H340	Recipient Station Number of All Stations in Co-inverter Communication 1	<div style="display: flex; justify-content: space-between; border-bottom: 1px solid black; padding-bottom: 2px;"> <span>V/f</span> <span>DTV</span> <span>PG V/f</span> <span>PG DTV</span> </div> <div style="display: flex; justify-content: space-between; border-bottom: 1px solid black; padding-bottom: 2px;"> <span>SLV</span> <span>PGV</span> <span>PM SLV</span> <span>PM PGV</span> </div> 1 to 247	1	Available	-	page 8-28
H341	Recipient Register of All Stations in Co-inverter Communication 1	<div style="display: flex; justify-content: space-between; border-bottom: 1px solid black; padding-bottom: 2px;"> <span>V/f</span> <span>DTV</span> <span>PG V/f</span> <span>PG DTV</span> </div> <div style="display: flex; justify-content: space-between; border-bottom: 1px solid black; padding-bottom: 2px;"> <span>SLV</span> <span>PGV</span> <span>PM SLV</span> <span>PM PGV</span> </div> 0000 to FFFF Hex	0000 hex	Available	-	page 8-28

Parameter No.	Function name	Monitor or Data Range	Default data	Setting during RUN	Unit	Page
H342	Sender Register of All Stations in Co-inverter Communication 1	<div style="display: flex; justify-content: space-between; border-bottom: 1px solid black; padding-bottom: 2px;"> <span>V/f</span> <span>DTV</span> <span>PG V/f</span> <span>PG DTV</span> </div> <div style="display: flex; justify-content: space-between; border-bottom: 1px solid black; padding-bottom: 2px;"> <span>SLV</span> <span>PGV</span> <span>PM SLV</span> <span>PM PGV</span> </div> 0000 to FFFF Hex	0000 hex	Available	-	page 8-28
H343	Recipient Station Number of All Stations in Co-inverter Communication 2	<div style="display: flex; justify-content: space-between; border-bottom: 1px solid black; padding-bottom: 2px;"> <span>V/f</span> <span>DTV</span> <span>PG V/f</span> <span>PG DTV</span> </div> <div style="display: flex; justify-content: space-between; border-bottom: 1px solid black; padding-bottom: 2px;"> <span>SLV</span> <span>PGV</span> <span>PM SLV</span> <span>PM PGV</span> </div> 1 to 247	2	Available	-	page 8-28
H344	Recipient Register of All Stations in Co-inverter Communication 2	<div style="display: flex; justify-content: space-between; border-bottom: 1px solid black; padding-bottom: 2px;"> <span>V/f</span> <span>DTV</span> <span>PG V/f</span> <span>PG DTV</span> </div> <div style="display: flex; justify-content: space-between; border-bottom: 1px solid black; padding-bottom: 2px;"> <span>SLV</span> <span>PGV</span> <span>PM SLV</span> <span>PM PGV</span> </div> 0000 to FFFF Hex	0000 hex	Available	-	page 8-28
H345	Sender Register of All Stations in Co-inverter Communication 2	<div style="display: flex; justify-content: space-between; border-bottom: 1px solid black; padding-bottom: 2px;"> <span>V/f</span> <span>DTV</span> <span>PG V/f</span> <span>PG DTV</span> </div> <div style="display: flex; justify-content: space-between; border-bottom: 1px solid black; padding-bottom: 2px;"> <span>SLV</span> <span>PGV</span> <span>PM SLV</span> <span>PM PGV</span> </div> 0000 to FFFF Hex	0000 hex	Available	-	page 8-28
H346	Recipient Station Number of All Stations in Co-inverter Communication 3	<div style="display: flex; justify-content: space-between; border-bottom: 1px solid black; padding-bottom: 2px;"> <span>V/f</span> <span>DTV</span> <span>PG V/f</span> <span>PG DTV</span> </div> <div style="display: flex; justify-content: space-between; border-bottom: 1px solid black; padding-bottom: 2px;"> <span>SLV</span> <span>PGV</span> <span>PM SLV</span> <span>PM PGV</span> </div> 1 to 247	3	Available	-	page 8-28
H347	Recipient Register of All Stations in Co-inverter Communication 3	<div style="display: flex; justify-content: space-between; border-bottom: 1px solid black; padding-bottom: 2px;"> <span>V/f</span> <span>DTV</span> <span>PG V/f</span> <span>PG DTV</span> </div> <div style="display: flex; justify-content: space-between; border-bottom: 1px solid black; padding-bottom: 2px;"> <span>SLV</span> <span>PGV</span> <span>PM SLV</span> <span>PM PGV</span> </div> 0000 to FFFF Hex	0000 hex	Available	-	page 8-28
H348	Sender Register of All Stations in Co-inverter Communication 3	<div style="display: flex; justify-content: space-between; border-bottom: 1px solid black; padding-bottom: 2px;"> <span>V/f</span> <span>DTV</span> <span>PG V/f</span> <span>PG DTV</span> </div> <div style="display: flex; justify-content: space-between; border-bottom: 1px solid black; padding-bottom: 2px;"> <span>SLV</span> <span>PGV</span> <span>PM SLV</span> <span>PM PGV</span> </div> 0000 to FFFF Hex	0000 hex	Available	-	page 8-28
H349	Recipient Station Number of All Stations in Co-inverter Communication 4	<div style="display: flex; justify-content: space-between; border-bottom: 1px solid black; padding-bottom: 2px;"> <span>V/f</span> <span>DTV</span> <span>PG V/f</span> <span>PG DTV</span> </div> <div style="display: flex; justify-content: space-between; border-bottom: 1px solid black; padding-bottom: 2px;"> <span>SLV</span> <span>PGV</span> <span>PM SLV</span> <span>PM PGV</span> </div> 1 to 247	4	Available	-	page 8-28
H350	Recipient Register of All Stations in Co-inverter Communication 4	<div style="display: flex; justify-content: space-between; border-bottom: 1px solid black; padding-bottom: 2px;"> <span>V/f</span> <span>DTV</span> <span>PG V/f</span> <span>PG DTV</span> </div> <div style="display: flex; justify-content: space-between; border-bottom: 1px solid black; padding-bottom: 2px;"> <span>SLV</span> <span>PGV</span> <span>PM SLV</span> <span>PM PGV</span> </div> 0000 to FFFF Hex	0000 hex	Available	-	page 8-28
H351	Sender Register of All Stations in Co-inverter Communication 4	<div style="display: flex; justify-content: space-between; border-bottom: 1px solid black; padding-bottom: 2px;"> <span>V/f</span> <span>DTV</span> <span>PG V/f</span> <span>PG DTV</span> </div> <div style="display: flex; justify-content: space-between; border-bottom: 1px solid black; padding-bottom: 2px;"> <span>SLV</span> <span>PGV</span> <span>PM SLV</span> <span>PM PGV</span> </div> 0000 to FFFF Hex	0000 hex	Available	-	page 8-28
H352	Recipient Station Number of All Stations in Co-inverter Communication 5	<div style="display: flex; justify-content: space-between; border-bottom: 1px solid black; padding-bottom: 2px;"> <span>V/f</span> <span>DTV</span> <span>PG V/f</span> <span>PG DTV</span> </div> <div style="display: flex; justify-content: space-between; border-bottom: 1px solid black; padding-bottom: 2px;"> <span>SLV</span> <span>PGV</span> <span>PM SLV</span> <span>PM PGV</span> </div> 1 to 247	5	Available	-	page 8-28
H353	Recipient Register of All Stations in Co-inverter Communication 5	<div style="display: flex; justify-content: space-between; border-bottom: 1px solid black; padding-bottom: 2px;"> <span>V/f</span> <span>DTV</span> <span>PG V/f</span> <span>PG DTV</span> </div> <div style="display: flex; justify-content: space-between; border-bottom: 1px solid black; padding-bottom: 2px;"> <span>SLV</span> <span>PGV</span> <span>PM SLV</span> <span>PM PGV</span> </div> 0000 to FFFF Hex	0000 hex	Available	-	page 8-28

Parameter No.	Function name	Monitor or Data Range	Default data	Setting during RUN	Unit	Page
H354	Sender Register of All Stations in Co-inverter Communication 5	<input type="checkbox"/> V/f <input type="checkbox"/> DTV <input type="checkbox"/> PG V/f <input type="checkbox"/> PG DTV <input type="checkbox"/> SLV <input type="checkbox"/> PGV <input type="checkbox"/> PM SLV <input type="checkbox"/> PM PGV 0000 to FFFF Hex	0000 hex	Available	-	page 8-28
H355	Modbus Mapping Function Selection	<input type="checkbox"/> V/f <input type="checkbox"/> DTV <input type="checkbox"/> PG V/f <input type="checkbox"/> PG DTV <input type="checkbox"/> SLV <input type="checkbox"/> PGV <input type="checkbox"/> PM SLV <input type="checkbox"/> PM PGV 0: Standard 1: Free mapping	0	-	-	page 8-23
H356	Modbus Mapping 1 External Register	<input type="checkbox"/> V/f <input type="checkbox"/> DTV <input type="checkbox"/> PG V/f <input type="checkbox"/> PG DTV <input type="checkbox"/> SLV <input type="checkbox"/> PGV <input type="checkbox"/> PM SLV <input type="checkbox"/> PM PGV 0000 to FFFF Hex	0000 hex	-	-	page 8-23
H357	Modbus Mapping 2 External Register	<input type="checkbox"/> V/f <input type="checkbox"/> DTV <input type="checkbox"/> PG V/f <input type="checkbox"/> PG DTV <input type="checkbox"/> SLV <input type="checkbox"/> PGV <input type="checkbox"/> PM SLV <input type="checkbox"/> PM PGV 0000 to FFFF Hex	0000 hex	-	-	page 8-23
H358	Modbus Mapping 3 External Register	<input type="checkbox"/> V/f <input type="checkbox"/> DTV <input type="checkbox"/> PG V/f <input type="checkbox"/> PG DTV <input type="checkbox"/> SLV <input type="checkbox"/> PGV <input type="checkbox"/> PM SLV <input type="checkbox"/> PM PGV 0000 to FFFF Hex	0000 hex	-	-	page 8-23
H359	Modbus Mapping 4 External Register	<input type="checkbox"/> V/f <input type="checkbox"/> DTV <input type="checkbox"/> PG V/f <input type="checkbox"/> PG DTV <input type="checkbox"/> SLV <input type="checkbox"/> PGV <input type="checkbox"/> PM SLV <input type="checkbox"/> PM PGV 0000 to FFFF Hex	0000 hex	-	-	page 8-23
H360	Modbus Mapping 5 External Register	<input type="checkbox"/> V/f <input type="checkbox"/> DTV <input type="checkbox"/> PG V/f <input type="checkbox"/> PG DTV <input type="checkbox"/> SLV <input type="checkbox"/> PGV <input type="checkbox"/> PM SLV <input type="checkbox"/> PM PGV 0000 to FFFF Hex	0000 hex	-	-	page 8-23
H361	Modbus Mapping 6 External Register	<input type="checkbox"/> V/f <input type="checkbox"/> DTV <input type="checkbox"/> PG V/f <input type="checkbox"/> PG DTV <input type="checkbox"/> SLV <input type="checkbox"/> PGV <input type="checkbox"/> PM SLV <input type="checkbox"/> PM PGV 0000 to FFFF Hex	0000 hex	-	-	page 8-23
H362	Modbus Mapping 7 External Register	<input type="checkbox"/> V/f <input type="checkbox"/> DTV <input type="checkbox"/> PG V/f <input type="checkbox"/> PG DTV <input type="checkbox"/> SLV <input type="checkbox"/> PGV <input type="checkbox"/> PM SLV <input type="checkbox"/> PM PGV 0000 to FFFF Hex	0000 hex	-	-	page 8-23
H363	Modbus Mapping 8 External Register	<input type="checkbox"/> V/f <input type="checkbox"/> DTV <input type="checkbox"/> PG V/f <input type="checkbox"/> PG DTV <input type="checkbox"/> SLV <input type="checkbox"/> PGV <input type="checkbox"/> PM SLV <input type="checkbox"/> PM PGV 0000 to FFFF Hex	0000 hex	-	-	page 8-23
H364	Modbus Mapping 9 External Register	<input type="checkbox"/> V/f <input type="checkbox"/> DTV <input type="checkbox"/> PG V/f <input type="checkbox"/> PG DTV <input type="checkbox"/> SLV <input type="checkbox"/> PGV <input type="checkbox"/> PM SLV <input type="checkbox"/> PM PGV 0000 to FFFF Hex	0000 hex	-	-	page 8-23
H365	Modbus Mapping 10 External Register	<input type="checkbox"/> V/f <input type="checkbox"/> DTV <input type="checkbox"/> PG V/f <input type="checkbox"/> PG DTV <input type="checkbox"/> SLV <input type="checkbox"/> PGV <input type="checkbox"/> PM SLV <input type="checkbox"/> PM PGV 0000 to FFFF Hex	0000 hex	-	-	page 8-23



Parameter No.	Function name	Monitor or Data Range	Default data	Setting during RUN	Unit	Page
H366	Modbus Mapping 1 External Register Sign	<input type="checkbox"/> V/f <input type="checkbox"/> DTV <input type="checkbox"/> PG V/f <input type="checkbox"/> PG DTV <input type="checkbox"/> SLV <input type="checkbox"/> PGV <input type="checkbox"/> PM SLV <input type="checkbox"/> PM PGV 0: Unsigned 1: Signed	0	-	-	page 8-23
H367	Modbus Mapping 2 External Register Sign	<input type="checkbox"/> V/f <input type="checkbox"/> DTV <input type="checkbox"/> PG V/f <input type="checkbox"/> PG DTV <input type="checkbox"/> SLV <input type="checkbox"/> PGV <input type="checkbox"/> PM SLV <input type="checkbox"/> PM PGV 0: Unsigned 1: Signed	0	-	-	page 8-23
H368	Modbus Mapping 3 External Register Sign	<input type="checkbox"/> V/f <input type="checkbox"/> DTV <input type="checkbox"/> PG V/f <input type="checkbox"/> PG DTV <input type="checkbox"/> SLV <input type="checkbox"/> PGV <input type="checkbox"/> PM SLV <input type="checkbox"/> PM PGV 0: Unsigned 1: Signed	0	-	-	page 8-23
H369	Modbus Mapping 4 External Register Sign	<input type="checkbox"/> V/f <input type="checkbox"/> DTV <input type="checkbox"/> PG V/f <input type="checkbox"/> PG DTV <input type="checkbox"/> SLV <input type="checkbox"/> PGV <input type="checkbox"/> PM SLV <input type="checkbox"/> PM PGV 0: Unsigned 1: Signed	0	-	-	page 8-23
H370	Modbus Mapping 5 External Register Sign	<input type="checkbox"/> V/f <input type="checkbox"/> DTV <input type="checkbox"/> PG V/f <input type="checkbox"/> PG DTV <input type="checkbox"/> SLV <input type="checkbox"/> PGV <input type="checkbox"/> PM SLV <input type="checkbox"/> PM PGV 0: Unsigned 1: Signed	0	-	-	page 8-23
H371	Modbus Mapping 6 External Register Sign	<input type="checkbox"/> V/f <input type="checkbox"/> DTV <input type="checkbox"/> PG V/f <input type="checkbox"/> PG DTV <input type="checkbox"/> SLV <input type="checkbox"/> PGV <input type="checkbox"/> PM SLV <input type="checkbox"/> PM PGV 0: Unsigned 1: Signed	0	-	-	page 8-23
H372	Modbus Mapping 7 External Register Sign	<input type="checkbox"/> V/f <input type="checkbox"/> DTV <input type="checkbox"/> PG V/f <input type="checkbox"/> PG DTV <input type="checkbox"/> SLV <input type="checkbox"/> PGV <input type="checkbox"/> PM SLV <input type="checkbox"/> PM PGV 0: Unsigned 1: Signed	0	-	-	page 8-23
H373	Modbus Mapping 8 External Register Sign	<input type="checkbox"/> V/f <input type="checkbox"/> DTV <input type="checkbox"/> PG V/f <input type="checkbox"/> PG DTV <input type="checkbox"/> SLV <input type="checkbox"/> PGV <input type="checkbox"/> PM SLV <input type="checkbox"/> PM PGV 0: Unsigned 1: Signed	0	-	-	page 8-23
H374	Modbus Mapping 9 External Register Sign	<input type="checkbox"/> V/f <input type="checkbox"/> DTV <input type="checkbox"/> PG V/f <input type="checkbox"/> PG DTV <input type="checkbox"/> SLV <input type="checkbox"/> PGV <input type="checkbox"/> PM SLV <input type="checkbox"/> PM PGV 0: Unsigned 1: Signed	0	-	-	page 8-23
H375	Modbus Mapping 10 External Register Sign	<input type="checkbox"/> V/f <input type="checkbox"/> DTV <input type="checkbox"/> PG V/f <input type="checkbox"/> PG DTV <input type="checkbox"/> SLV <input type="checkbox"/> PGV <input type="checkbox"/> PM SLV <input type="checkbox"/> PM PGV 0: Unsigned 1: Signed	0	-	-	page 8-23

Parameter No.	Function name	Monitor or Data Range	Default data	Setting during RUN	Unit	Page
H376	Modbus Mapping 1 Scaling	<input type="checkbox"/> V/f <input type="checkbox"/> DTV <input type="checkbox"/> PG V/f <input type="checkbox"/> PG DTV <input type="checkbox"/> SLV <input type="checkbox"/> PGV <input type="checkbox"/> PM SLV <input type="checkbox"/> PM PGV 0.001 to 65.53	1.000	-	-	page 8-23
H377	Modbus Mapping 2 Scaling	<input type="checkbox"/> V/f <input type="checkbox"/> DTV <input type="checkbox"/> PG V/f <input type="checkbox"/> PG DTV <input type="checkbox"/> SLV <input type="checkbox"/> PGV <input type="checkbox"/> PM SLV <input type="checkbox"/> PM PGV 0.001 to 65.53	1.000	-	-	page 8-23
H378	Modbus Mapping 3 Scaling	<input type="checkbox"/> V/f <input type="checkbox"/> DTV <input type="checkbox"/> PG V/f <input type="checkbox"/> PG DTV <input type="checkbox"/> SLV <input type="checkbox"/> PGV <input type="checkbox"/> PM SLV <input type="checkbox"/> PM PGV 0.001 to 65.53	1.000	-	-	page 8-23
H379	Modbus Mapping 4 Scaling	<input type="checkbox"/> V/f <input type="checkbox"/> DTV <input type="checkbox"/> PG V/f <input type="checkbox"/> PG DTV <input type="checkbox"/> SLV <input type="checkbox"/> PGV <input type="checkbox"/> PM SLV <input type="checkbox"/> PM PGV 0.001 to 65.53	1.000	-	-	page 8-23
H380	Modbus Mapping 5 Scaling	<input type="checkbox"/> V/f <input type="checkbox"/> DTV <input type="checkbox"/> PG V/f <input type="checkbox"/> PG DTV <input type="checkbox"/> SLV <input type="checkbox"/> PGV <input type="checkbox"/> PM SLV <input type="checkbox"/> PM PGV 0.001 to 65.53	1.000	-	-	page 8-23
H381	Modbus Mapping 6 Scaling	<input type="checkbox"/> V/f <input type="checkbox"/> DTV <input type="checkbox"/> PG V/f <input type="checkbox"/> PG DTV <input type="checkbox"/> SLV <input type="checkbox"/> PGV <input type="checkbox"/> PM SLV <input type="checkbox"/> PM PGV 0.001 to 65.53	1.000	-	-	page 8-23
H382	Modbus Mapping 7 Scaling	<input type="checkbox"/> V/f <input type="checkbox"/> DTV <input type="checkbox"/> PG V/f <input type="checkbox"/> PG DTV <input type="checkbox"/> SLV <input type="checkbox"/> PGV <input type="checkbox"/> PM SLV <input type="checkbox"/> PM PGV 0.001 to 65.53	1.000	-	-	page 8-23
H383	Modbus Mapping 8 Scaling	<input type="checkbox"/> V/f <input type="checkbox"/> DTV <input type="checkbox"/> PG V/f <input type="checkbox"/> PG DTV <input type="checkbox"/> SLV <input type="checkbox"/> PGV <input type="checkbox"/> PM SLV <input type="checkbox"/> PM PGV 0.001 to 65.53	1.000	-	-	page 8-23
H384	Modbus Mapping 9 Scaling	<input type="checkbox"/> V/f <input type="checkbox"/> DTV <input type="checkbox"/> PG V/f <input type="checkbox"/> PG DTV <input type="checkbox"/> SLV <input type="checkbox"/> PGV <input type="checkbox"/> PM SLV <input type="checkbox"/> PM PGV 0.001 to 65.53	1.000	-	-	page 8-23
H385	Modbus Mapping 10 Scaling	<input type="checkbox"/> V/f <input type="checkbox"/> DTV <input type="checkbox"/> PG V/f <input type="checkbox"/> PG DTV <input type="checkbox"/> SLV <input type="checkbox"/> PGV <input type="checkbox"/> PM SLV <input type="checkbox"/> PM PGV 0.001 to 65.53	1.000	-	-	page 8-23
H386	Modbus Mapping 1 Internal Register	<input type="checkbox"/> V/f <input type="checkbox"/> DTV <input type="checkbox"/> PG V/f <input type="checkbox"/> PG DTV <input type="checkbox"/> SLV <input type="checkbox"/> PGV <input type="checkbox"/> PM SLV <input type="checkbox"/> PM PGV 0000 to FFFF Hex	0000 hex	-	-	page 8-23
H387	Modbus Mapping 2 Internal Register	<input type="checkbox"/> V/f <input type="checkbox"/> DTV <input type="checkbox"/> PG V/f <input type="checkbox"/> PG DTV <input type="checkbox"/> SLV <input type="checkbox"/> PGV <input type="checkbox"/> PM SLV <input type="checkbox"/> PM PGV 0000 to FFFF Hex	0000 hex	-	-	page 8-23

Parameter No.	Function name	Monitor or Data Range	Default data	Setting during RUN	Unit	Page
H388	Modbus Mapping 3 Internal Register	<div style="display: flex; justify-content: space-between; border-bottom: 1px solid black; padding-bottom: 2px;"> <span>V/f</span> <span>DTV</span> <span>PG V/f</span> <span>PG DTV</span> </div> <div style="display: flex; justify-content: space-between; border-bottom: 1px solid black; padding-bottom: 2px;"> <span>SLV</span> <span>PGV</span> <span>PM SLV</span> <span>PM PGV</span> </div> 0000 to FFFF Hex	0000 hex	-	-	page 8-23
H389	Modbus Mapping 4 Internal Register	<div style="display: flex; justify-content: space-between; border-bottom: 1px solid black; padding-bottom: 2px;"> <span>V/f</span> <span>DTV</span> <span>PG V/f</span> <span>PG DTV</span> </div> <div style="display: flex; justify-content: space-between; border-bottom: 1px solid black; padding-bottom: 2px;"> <span>SLV</span> <span>PGV</span> <span>PM SLV</span> <span>PM PGV</span> </div> 0000 to FFFF Hex	0000 hex	-	-	page 8-23
H390	Modbus Mapping 5 Internal Register	<div style="display: flex; justify-content: space-between; border-bottom: 1px solid black; padding-bottom: 2px;"> <span>V/f</span> <span>DTV</span> <span>PG V/f</span> <span>PG DTV</span> </div> <div style="display: flex; justify-content: space-between; border-bottom: 1px solid black; padding-bottom: 2px;"> <span>SLV</span> <span>PGV</span> <span>PM SLV</span> <span>PM PGV</span> </div> 0000 to FFFF Hex	0000 hex	-	-	page 8-23
H391	Modbus Mapping 6 Internal Register	<div style="display: flex; justify-content: space-between; border-bottom: 1px solid black; padding-bottom: 2px;"> <span>V/f</span> <span>DTV</span> <span>PG V/f</span> <span>PG DTV</span> </div> <div style="display: flex; justify-content: space-between; border-bottom: 1px solid black; padding-bottom: 2px;"> <span>SLV</span> <span>PGV</span> <span>PM SLV</span> <span>PM PGV</span> </div> 0000 to FFFF Hex	0000 hex	-	-	page 8-23
H392	Modbus Mapping 7 Internal Register	<div style="display: flex; justify-content: space-between; border-bottom: 1px solid black; padding-bottom: 2px;"> <span>V/f</span> <span>DTV</span> <span>PG V/f</span> <span>PG DTV</span> </div> <div style="display: flex; justify-content: space-between; border-bottom: 1px solid black; padding-bottom: 2px;"> <span>SLV</span> <span>PGV</span> <span>PM SLV</span> <span>PM PGV</span> </div> 0000 to FFFF Hex	0000 hex	-	-	page 8-23
H393	Modbus Mapping 8 Internal Register	<div style="display: flex; justify-content: space-between; border-bottom: 1px solid black; padding-bottom: 2px;"> <span>V/f</span> <span>DTV</span> <span>PG V/f</span> <span>PG DTV</span> </div> <div style="display: flex; justify-content: space-between; border-bottom: 1px solid black; padding-bottom: 2px;"> <span>SLV</span> <span>PGV</span> <span>PM SLV</span> <span>PM PGV</span> </div> 0000 to FFFF Hex	0000 hex	-	-	page 8-23
H394	Modbus Mapping 9 Internal Register	<div style="display: flex; justify-content: space-between; border-bottom: 1px solid black; padding-bottom: 2px;"> <span>V/f</span> <span>DTV</span> <span>PG V/f</span> <span>PG DTV</span> </div> <div style="display: flex; justify-content: space-between; border-bottom: 1px solid black; padding-bottom: 2px;"> <span>SLV</span> <span>PGV</span> <span>PM SLV</span> <span>PM PGV</span> </div> 0000 to FFFF Hex	0000 hex	-	-	page 8-23
H395	Modbus Mapping 10 Internal Register	<div style="display: flex; justify-content: space-between; border-bottom: 1px solid black; padding-bottom: 2px;"> <span>V/f</span> <span>DTV</span> <span>PG V/f</span> <span>PG DTV</span> </div> <div style="display: flex; justify-content: space-between; border-bottom: 1px solid black; padding-bottom: 2px;"> <span>SLV</span> <span>PGV</span> <span>PM SLV</span> <span>PM PGV</span> </div> 0000 to FFFF Hex	0000 hex	-	-	page 8-23
H396	Modbus Mapping Endian Selection	<div style="display: flex; justify-content: space-between; border-bottom: 1px solid black; padding-bottom: 2px;"> <span>V/f</span> <span>DTV</span> <span>PG V/f</span> <span>PG DTV</span> </div> <div style="display: flex; justify-content: space-between; border-bottom: 1px solid black; padding-bottom: 2px;"> <span>SLV</span> <span>PGV</span> <span>PM SLV</span> <span>PM PGV</span> </div> 0: Big endian 1: Little endian 2: Special endian	0	-	-	page 8-23
H411	Input Phase Loss Protection Function Selection	<div style="display: flex; justify-content: space-between; border-bottom: 1px solid black; padding-bottom: 2px;"> <span>V/f</span> <span>DTV</span> <span>PG V/f</span> <span>PG DTV</span> </div> <div style="display: flex; justify-content: space-between; border-bottom: 1px solid black; padding-bottom: 2px;"> <span>SLV</span> <span>PGV</span> <span>PM SLV</span> <span>PM PGV</span> </div> 0: Disable (Continue to run) 1: Enable (Trip)	1	Available	-	page 7-111
H412	Output Phase Loss Protection Function Selection	<div style="display: flex; justify-content: space-between; border-bottom: 1px solid black; padding-bottom: 2px;"> <span>V/f</span> <span>DTV</span> <span>PG V/f</span> <span>PG DTV</span> </div> <div style="display: flex; justify-content: space-between; border-bottom: 1px solid black; padding-bottom: 2px;"> <span>SLV</span> <span>PGV</span> <span>PM SLV</span> <span>PM PGV</span> </div> 0: Disable (Continue to run) 1: Enable (Trip)	0	Available	-	page 7-111

Parameter No.	Function name	Monitor or Data Range	Default data	Setting during RUN	Unit	Page
H435	Touch Probe 1 Source	<div style="display: flex; justify-content: space-between; border-bottom: 1px solid black; padding-bottom: 2px;"> <span>V/f</span> <span>DTV</span> <span>PG V/f</span> <span>PG DTV</span> </div> <div style="display: flex; justify-content: space-between; border-bottom: 1px solid black; padding-bottom: 2px;"> <span>SLV</span> <span>PGV</span> <span>PM SLV</span> <span>PM PGV</span> </div> 1: External Latch Input 1 (EXT1) 2: External Latch Input 2 (EXT2) 6: Phase Z	1	-	-	page 6-62
H436	Touch Probe 2 Source	<div style="display: flex; justify-content: space-between; border-bottom: 1px solid black; padding-bottom: 2px;"> <span>V/f</span> <span>DTV</span> <span>PG V/f</span> <span>PG DTV</span> </div> <div style="display: flex; justify-content: space-between; border-bottom: 1px solid black; padding-bottom: 2px;"> <span>SLV</span> <span>PGV</span> <span>PM SLV</span> <span>PM PGV</span> </div> 1: External Latch Input 1 (EXT1) 2: External Latch Input 2 (EXT2) 6: Phase Z	2	-	-	page 6-62
H437	Touch Probe Function	<div style="display: flex; justify-content: space-between; border-bottom: 1px solid black; padding-bottom: 2px;"> <span>V/f</span> <span>DTV</span> <span>PG V/f</span> <span>PG DTV</span> </div> <div style="display: flex; justify-content: space-between; border-bottom: 1px solid black; padding-bottom: 2px;"> <span>SLV</span> <span>PGV</span> <span>PM SLV</span> <span>PM PGV</span> </div> Bit15 to 13: Fixed to 0 Bit12: Latch operation 2 0: Disable 1: Enable Bit11 to 10: Latch trigger 2 00: EXT2 01: Phase Z 10: H435/H436 (60D0 Hex) 11: Reserved (No-trigger) Bit9: Latch mode 2 0: Trigger First Event Mode 1: Continuous Mode Bit8: Latch function 2 0: Disable 1: Enable Bit7 to 5: Fixed to 0 Bit4: Latch operation 1 0: Disable 1: Enable Bit3 to 2: Latch trigger 1 00: EXT1 01: Phase Z 10: H435/H436 (60D0 Hex) 11: Reserved (No-trigger) Bit1: Latch mode 1 0: Trigger First Event Mode 1: Continuous Mode) Bit0: Latch function 1 0: Disable 1: Enable	0	Available	-	page 6-62

Parameter No.	Function name	Monitor or Data Range	Default data	Setting during RUN	Unit	Page
H438	Feedback Value Comparison Signal Off Level	<div style="display: flex; justify-content: space-between; border-bottom: 1px solid black; padding-bottom: 2px;"> <span>V/f</span> <span>DTV</span> <span>PG V/f</span> <span>PG DTV</span> </div> <div style="display: flex; justify-content: space-between; border-bottom: 1px solid black; padding-bottom: 2px;"> <span>SLV</span> <span>PGV</span> <span>PM SLV</span> <span>PM PGV</span> </div> 0.0 to 100.0%	100.0	-	%	page 7-123
H439	Feedback Value Comparison Signal On Level	<div style="display: flex; justify-content: space-between; border-bottom: 1px solid black; padding-bottom: 2px;"> <span>V/f</span> <span>DTV</span> <span>PG V/f</span> <span>PG DTV</span> </div> <div style="display: flex; justify-content: space-between; border-bottom: 1px solid black; padding-bottom: 2px;"> <span>SLV</span> <span>PGV</span> <span>PM SLV</span> <span>PM PGV</span> </div> 0.0 to 100.0%	0.0	-	%	page 7-123
H440	Free Run Stop Restart Allowable Time	<div style="display: flex; justify-content: space-between; border-bottom: 1px solid black; padding-bottom: 2px;"> <span>V/f</span> <span>DTV</span> <span>PG V/f</span> <span>PG DTV</span> </div> <div style="display: flex; justify-content: space-between; border-bottom: 1px solid black; padding-bottom: 2px;"> <span>SLV</span> <span>PGV</span> <span>PM SLV</span> <span>PM PGV</span> </div> 0.0 to 30.0 s	30.0	-	s	page 7-60
H441	Free Run Stop Restart Operation Selection	<div style="display: flex; justify-content: space-between; border-bottom: 1px solid black; padding-bottom: 2px;"> <span>V/f</span> <span>DTV</span> <span>PG V/f</span> <span>PG DTV</span> </div> <div style="display: flex; justify-content: space-between; border-bottom: 1px solid black; padding-bottom: 2px;"> <span>SLV</span> <span>PGV</span> <span>PM SLV</span> <span>PM PGV</span> </div> 1: Starting with matching frequency 2: Starting with active matching frequency	2	-	-	page 7-60
H442	Slip compensation Function Selection	<div style="display: flex; justify-content: space-between; border-bottom: 1px solid black; padding-bottom: 2px;"> <span>V/f</span> <span>DTV</span> <span>PG V/f</span> <span>PG DTV</span> </div> <div style="display: flex; justify-content: space-between; border-bottom: 1px solid black; padding-bottom: 2px;"> <span>SLV</span> <span>PGV</span> <span>PM SLV</span> <span>PM PGV</span> </div> 0: Disable 1: Enable	0	Available	-	page 5-16

#### 4-2-6 Parameter A (Motor 2 Parameter)

Parameter No.	Function name	Monitor or Data Range	Default data	Setting during RUN	Unit	Page
A01	2nd Maximum Output Frequency	<div style="display: flex; justify-content: space-between; border-bottom: 1px solid black; padding-bottom: 2px;"> <span>V/f</span> <span>DTV</span> <span>PG V/f</span> <span>PG DTV</span> </div> <div style="display: flex; justify-content: space-between; border-bottom: 1px solid black; padding-bottom: 2px;"> <span>SLV</span> <span>PGV</span> <span>PM SLV</span> <span>PM PGV</span> </div> 5.0 to 590.0 Hz	60.0	-	Hz	page 5-19
A02	2nd Base Frequency	<div style="display: flex; justify-content: space-between; border-bottom: 1px solid black; padding-bottom: 2px;"> <span>V/f</span> <span>DTV</span> <span>PG V/f</span> <span>PG DTV</span> </div> <div style="display: flex; justify-content: space-between; border-bottom: 1px solid black; padding-bottom: 2px;"> <span>SLV</span> <span>PGV</span> <span>PM SLV</span> <span>PM PGV</span> </div> 5.0 to 590.0 Hz	50.0	-	Hz	page 5-19
A03	2nd Rated Voltage at Base Frequency	<div style="display: flex; justify-content: space-between; border-bottom: 1px solid black; padding-bottom: 2px;"> <span>V/f</span> <span>DTV</span> <span>PG V/f</span> <span>PG DTV</span> </div> <div style="display: flex; justify-content: space-between; border-bottom: 1px solid black; padding-bottom: 2px;"> <span>SLV</span> <span>PGV</span> <span>PM SLV</span> <span>PM PGV</span> </div> 80 to 240 V: AVR operation (200 V class series) 160 to 500 V: AVR operation (400 V class series)	200	-	V	page 5-19

Parameter No.	Function name	Monitor or Data Range	Default data	Setting during RUN	Unit	Page
A04	2nd Rated Voltage at Maximum Output Frequency	<div style="display: flex; justify-content: space-between; border-bottom: 1px solid black; padding-bottom: 2px;"> <span>V/f</span> <span>DTV</span> <span>PG V/f</span> <span>PG DTV</span> </div> <div style="display: flex; justify-content: space-between; border-bottom: 1px solid black; padding-bottom: 2px;"> <span>SLV</span> <span>PGV</span> <span>PM SLV</span> <span>PM PGV</span> </div> <p>80 to 240 V: AVR operation (200 V class series) 160 to 500 V: AVR operation (400 V class series)</p>	200	-	V	page 5-19
A05	2nd Manual Torque Boost Voltage	<div style="display: flex; justify-content: space-between; border-bottom: 1px solid black; padding-bottom: 2px;"> <span>V/f</span> <span>DTV</span> <span>PG V/f</span> <span>PG DTV</span> </div> <div style="display: flex; justify-content: space-between; border-bottom: 1px solid black; padding-bottom: 2px;"> <span>SLV</span> <span>PGV</span> <span>PM SLV</span> <span>PM PGV</span> </div> <p>0.0 to 20.0 % Percentage with respect to 2nd rated voltage at base frequency (A003)</p>	1.9	Available	%	page 5-73
A06	2nd Motor Electronic Thermal Characteristic selection	<div style="display: flex; justify-content: space-between; border-bottom: 1px solid black; padding-bottom: 2px;"> <span>V/f</span> <span>DTV</span> <span>PG V/f</span> <span>PG DTV</span> </div> <div style="display: flex; justify-content: space-between; border-bottom: 1px solid black; padding-bottom: 2px;"> <span>SLV</span> <span>PGV</span> <span>PM SLV</span> <span>PM PGV</span> </div> <p>1: For a general-purpose motor with shaft-driven cooling fan 2: For an inverter-driven motor non-ventilated motor or motor with separately powered cooling fan</p>	1	Available	-	page 5-20
A07	2nd Motor Electronic Thermal Level	<div style="display: flex; justify-content: space-between; border-bottom: 1px solid black; padding-bottom: 2px;"> <span>V/f</span> <span>DTV</span> <span>PG V/f</span> <span>PG DTV</span> </div> <div style="display: flex; justify-content: space-between; border-bottom: 1px solid black; padding-bottom: 2px;"> <span>SLV</span> <span>PGV</span> <span>PM SLV</span> <span>PM PGV</span> </div> <p>0.00 ; 0.01 to 118.8 0.00 : Disable 0.01 to 118.8 A</p> <p>* Setting range from 1%(HHD) to 135%(ND) of the rated inverter current.</p>	21	Available	A	page 5-20
A08	2nd Motor Electronic Thermal Time Constant	<div style="display: flex; justify-content: space-between; border-bottom: 1px solid black; padding-bottom: 2px;"> <span>V/f</span> <span>DTV</span> <span>PG V/f</span> <span>PG DTV</span> </div> <div style="display: flex; justify-content: space-between; border-bottom: 1px solid black; padding-bottom: 2px;"> <span>SLV</span> <span>PGV</span> <span>PM SLV</span> <span>PM PGV</span> </div> <p>0.5 to 75.0 min</p>	5	Available	min	page 5-20
A09	2nd DC Injection Braking Start Frequency	<div style="display: flex; justify-content: space-between; border-bottom: 1px solid black; padding-bottom: 2px;"> <span>V/f</span> <span>DTV</span> <span>PG V/f</span> <span>PG DTV</span> </div> <div style="display: flex; justify-content: space-between; border-bottom: 1px solid black; padding-bottom: 2px;"> <span>SLV</span> <span>PGV</span> <span>PM SLV</span> <span>PM PGV</span> </div> <p>0.0 to 60.0 Hz</p>	0.0	Available	Hz	page 7-63
A10	2nd DC Injection Braking Level	<div style="display: flex; justify-content: space-between; border-bottom: 1px solid black; padding-bottom: 2px;"> <span>V/f</span> <span>DTV</span> <span>PG V/f</span> <span>PG DTV</span> </div> <div style="display: flex; justify-content: space-between; border-bottom: 1px solid black; padding-bottom: 2px;"> <span>SLV</span> <span>PGV</span> <span>PM SLV</span> <span>PM PGV</span> </div> <p>0 to 100% (HHD mode) 0 to 80% (HND/HD mode) 0 to 60% (ND mode) Based on inverter rated current</p>	0	Available	%	page 7-63

Parameter No.	Function name	Monitor or Data Range	Default data	Setting during RUN	Unit	Page
A11	2nd DC Injection Braking Time	<div style="display: flex; justify-content: space-between; border-bottom: 1px solid black; margin-bottom: 5px;"> <span>V/f</span> <span>DTV</span> <span>PG V/f</span> <span>PG DTV</span> </div> <div style="display: flex; justify-content: space-between; border-bottom: 1px solid black; margin-bottom: 5px;"> <span>SLV</span> <span>PGV</span> <span>PM SLV</span> <span>PM PGV</span> </div> 0.00: Disable 0.01 to 30.00 s	0.00	Available	s	page 7-63
A12	2nd Starting Frequency	<div style="display: flex; justify-content: space-between; border-bottom: 1px solid black; margin-bottom: 5px;"> <span>V/f</span> <span>DTV</span> <span>PG V/f</span> <span>PG DTV</span> </div> <div style="display: flex; justify-content: space-between; border-bottom: 1px solid black; margin-bottom: 5px;"> <span>SLV</span> <span>PGV</span> <span>PM SLV</span> <span>PM PGV</span> </div> 0.0 to 60.0 Hz	0.5	Available	Hz	page 7-114
A13	2nd V/f Characteristics Selection	<div style="display: flex; justify-content: space-between; border-bottom: 1px solid black; margin-bottom: 5px;"> <span>V/f</span> <span>DTV</span> <span>PG V/f</span> <span>PG DTV</span> </div> <div style="display: flex; justify-content: space-between; border-bottom: 1px solid black; margin-bottom: 5px;"> <span>SLV</span> <span>PGV</span> <span>PM SLV</span> <span>PM PGV</span> </div> 0: Variable torque load 1: Constant torque load	1	-	-	page 5-10
A14	2nd Drive Control Selection	<div style="display: flex; justify-content: space-between; border-bottom: 1px solid black; margin-bottom: 5px;"> <span>V/f</span> <span>DTV</span> <span>PG V/f</span> <span>PG DTV</span> </div> <div style="display: flex; justify-content: space-between; border-bottom: 1px solid black; margin-bottom: 5px;"> <span>SLV</span> <span>PGV</span> <span>PM SLV</span> <span>PM PGV</span> </div> 0: IM V/f control 1: IM Dynamic torque vector control without speed sensor 3: IM V/f control with speed sensor 4: IM Dynamic torque vector control with speed sensor 5: IM Vector control without speed sensor 6: IM Vector control with speed sensor	0	-	-	page 5-10 page 6-16 page 6-11 page 6-21
A15	2nd Motor Pole Number	<div style="display: flex; justify-content: space-between; border-bottom: 1px solid black; margin-bottom: 5px;"> <span>V/f</span> <span>DTV</span> <span>PG V/f</span> <span>PG DTV</span> </div> <div style="display: flex; justify-content: space-between; border-bottom: 1px solid black; margin-bottom: 5px;"> <span>SLV</span> <span>PGV</span> <span>PM SLV</span> <span>PM PGV</span> </div> 2 to 128 poles	4	-	Pole	page 5-19
A16	2nd Motor Capacity	<div style="display: flex; justify-content: space-between; border-bottom: 1px solid black; margin-bottom: 5px;"> <span>V/f</span> <span>DTV</span> <span>PG V/f</span> <span>PG DTV</span> </div> <div style="display: flex; justify-content: space-between; border-bottom: 1px solid black; margin-bottom: 5px;"> <span>SLV</span> <span>PGV</span> <span>PM SLV</span> <span>PM PGV</span> </div> 0.01 to 1000 kW	5.50	-	kW	page 5-19
A17	2nd Motor Rated Current	<div style="display: flex; justify-content: space-between; border-bottom: 1px solid black; margin-bottom: 5px;"> <span>V/f</span> <span>DTV</span> <span>PG V/f</span> <span>PG DTV</span> </div> <div style="display: flex; justify-content: space-between; border-bottom: 1px solid black; margin-bottom: 5px;"> <span>SLV</span> <span>PGV</span> <span>PM SLV</span> <span>PM PGV</span> </div> 0.00 to 2000 A	21	-	A	page 6-4
A18	2nd Auto-tuning Selection Function Selection	<div style="display: flex; justify-content: space-between; border-bottom: 1px solid black; margin-bottom: 5px;"> <span>V/f</span> <span>DTV</span> <span>PG V/f</span> <span>PG DTV</span> </div> <div style="display: flex; justify-content: space-between; border-bottom: 1px solid black; margin-bottom: 5px;"> <span>SLV</span> <span>PGV</span> <span>PM SLV</span> <span>PM PGV</span> </div> 0: Disable 1: Tune the motor parameters while stopped 2: Tune the motor parameters while rotating 5: Tune the motor %R1 and %X while stopped	0	-	-	page 6-65

Parameter No.	Function name	Monitor or Data Range	Default data	Setting during RUN	Unit	Page
A19	2nd Online tuning Function Selection	<input type="checkbox"/> V/f <input type="checkbox"/> DTV <input checked="" type="checkbox"/> PG V/f <input checked="" type="checkbox"/> PG DTV <input type="checkbox"/> SLV <input type="checkbox"/> PGV <input checked="" type="checkbox"/> PM SLV <input checked="" type="checkbox"/> PM PGV 0: Disable 1: Enable	0	Available	-	page 6-71
A20	2nd Motor Armature Resistance	<input type="checkbox"/> V/f <input type="checkbox"/> DTV <input checked="" type="checkbox"/> PG V/f <input checked="" type="checkbox"/> PG DTV <input type="checkbox"/> SLV <input type="checkbox"/> PGV <input checked="" type="checkbox"/> PM SLV <input checked="" type="checkbox"/> PM PGV 0.00 to 500.0 A	10.55	-	A	page 6-6
A21	2nd Motor Motor Constant %R1	<input type="checkbox"/> V/f <input type="checkbox"/> DTV <input checked="" type="checkbox"/> PG V/f <input checked="" type="checkbox"/> PG DTV <input type="checkbox"/> SLV <input type="checkbox"/> PGV <input checked="" type="checkbox"/> PM SLV <input checked="" type="checkbox"/> PM PGV 0.00 to 50.00 %	3.17	Available	%	page 6-65
A22	2nd Motor Motor Constant %X	<input type="checkbox"/> V/f <input type="checkbox"/> DTV <input checked="" type="checkbox"/> PG V/f <input checked="" type="checkbox"/> PG DTV <input type="checkbox"/> SLV <input type="checkbox"/> PGV <input checked="" type="checkbox"/> PM SLV <input checked="" type="checkbox"/> PM PGV 0.00 to 50.00 %	11.47	Available	%	page 6-65
A23	2nd Slip Compensation Gain for Driving	<input type="checkbox"/> V/f <input type="checkbox"/> DTV <input checked="" type="checkbox"/> PG V/f <input checked="" type="checkbox"/> PG DTV <input type="checkbox"/> SLV <input type="checkbox"/> PGV <input checked="" type="checkbox"/> PM SLV <input checked="" type="checkbox"/> PM PGV 0.0 to 200.0 %	100.0	Available	%	page 5-16
A24	2nd Slip Compensation Response Time	<input type="checkbox"/> V/f <input type="checkbox"/> DTV <input checked="" type="checkbox"/> PG V/f <input checked="" type="checkbox"/> PG DTV <input type="checkbox"/> SLV <input type="checkbox"/> PGV <input checked="" type="checkbox"/> PM SLV <input checked="" type="checkbox"/> PM PGV 0.01 to 10.00 s	0.12	Available	s	page 5-16
A25	2nd Slip Compensation Gain for Braking	<input type="checkbox"/> V/f <input type="checkbox"/> DTV <input checked="" type="checkbox"/> PG V/f <input checked="" type="checkbox"/> PG DTV <input type="checkbox"/> SLV <input type="checkbox"/> PGV <input checked="" type="checkbox"/> PM SLV <input checked="" type="checkbox"/> PM PGV 0.0 to 200.0 %	100.0	Available	%	page 5-16
A26	2nd Rated Slip Frequency	<input type="checkbox"/> V/f <input type="checkbox"/> DTV <input checked="" type="checkbox"/> PG V/f <input checked="" type="checkbox"/> PG DTV <input type="checkbox"/> SLV <input type="checkbox"/> PGV <input checked="" type="checkbox"/> PM SLV <input checked="" type="checkbox"/> PM PGV 0.00 to 15.00 Hz	1	-	Hz	page 5-16
A27	2nd Iron Loss Factor 1	<input type="checkbox"/> V/f <input type="checkbox"/> DTV <input checked="" type="checkbox"/> PG V/f <input checked="" type="checkbox"/> PG DTV <input type="checkbox"/> SLV <input type="checkbox"/> PGV <input checked="" type="checkbox"/> PM SLV <input checked="" type="checkbox"/> PM PGV 0.00 to 20.00 %	2.86	Available	%	page 6-6
A30	2nd Magnetic Saturation Factor 1	<input checked="" type="checkbox"/> V/f <input type="checkbox"/> DTV <input checked="" type="checkbox"/> PG V/f <input checked="" type="checkbox"/> PG DTV <input type="checkbox"/> SLV <input type="checkbox"/> PGV <input checked="" type="checkbox"/> PM SLV <input checked="" type="checkbox"/> PM PGV 0.0 to 300.0 %	92	Available	%	page 6-65
A31	2nd Magnetic Saturation Factor 2	<input checked="" type="checkbox"/> V/f <input type="checkbox"/> DTV <input checked="" type="checkbox"/> PG V/f <input checked="" type="checkbox"/> PG DTV <input type="checkbox"/> SLV <input type="checkbox"/> PGV <input checked="" type="checkbox"/> PM SLV <input checked="" type="checkbox"/> PM PGV 0.0 to 300.0 %	84.2	Available	%	page 6-65
A32	2nd Magnetic Saturation Factor 3	<input checked="" type="checkbox"/> V/f <input type="checkbox"/> DTV <input checked="" type="checkbox"/> PG V/f <input checked="" type="checkbox"/> PG DTV <input type="checkbox"/> SLV <input type="checkbox"/> PGV <input checked="" type="checkbox"/> PM SLV <input checked="" type="checkbox"/> PM PGV 0.0 to 300.0 %	70.5	Available	%	page 6-65



Parameter No.	Function name	Monitor or Data Range	Default data	Setting during RUN	Unit	Page
A33	2nd Magnetic Saturation Factor 4	<div style="display: flex; justify-content: space-between; border-bottom: 1px solid black; padding-bottom: 2px;"> <span>V/f</span> <span>DTV</span> <span>PG V/f</span> <span>PG DTV</span> </div> <div style="display: flex; justify-content: space-between; border-bottom: 1px solid black; padding-bottom: 2px;"> <span>SLV</span> <span>PGV</span> <span>PM SLV</span> <span>PM PGV</span> </div> 0.0 to 300.0 %	58.3	Available	%	page 6-65
A34	2nd Magnetic Saturation Factor 5	<div style="display: flex; justify-content: space-between; border-bottom: 1px solid black; padding-bottom: 2px;"> <span>V/f</span> <span>DTV</span> <span>PG V/f</span> <span>PG DTV</span> </div> <div style="display: flex; justify-content: space-between; border-bottom: 1px solid black; padding-bottom: 2px;"> <span>SLV</span> <span>PGV</span> <span>PM SLV</span> <span>PM PGV</span> </div> 0.0 to 300.0 %	46.1	Available	%	page 6-65
A40	2nd Slip Compensation Operating Conditions Selection	<div style="display: flex; justify-content: space-between; border-bottom: 1px solid black; padding-bottom: 2px;"> <span>V/f</span> <span>DTV</span> <span>PG V/f</span> <span>PG DTV</span> </div> <div style="display: flex; justify-content: space-between; border-bottom: 1px solid black; padding-bottom: 2px;"> <span>SLV</span> <span>PGV</span> <span>PM SLV</span> <span>PM PGV</span> </div> 0: Enable during acceleration/ deceleration, enable at base frequency or higher 1: Disable during acceleration/ deceleration, enable at base frequency or higher 2: Enable during acceleration/ deceleration, disable at base frequency or higher 3: Disable during acceleration/ deceleration, disable at base frequency or higher	0	-	-	page 5-16
A41	2nd Output Current Fluctuation Damping Gain	<div style="display: flex; justify-content: space-between; border-bottom: 1px solid black; padding-bottom: 2px;"> <span>V/f</span> <span>DTV</span> <span>PG V/f</span> <span>PG DTV</span> </div> <div style="display: flex; justify-content: space-between; border-bottom: 1px solid black; padding-bottom: 2px;"> <span>SLV</span> <span>PGV</span> <span>PM SLV</span> <span>PM PGV</span> </div> 0.00 to 1.00	0.20	Available	-	page 7-144
A43	Speed Control 2 Speed Command Filter	<div style="display: flex; justify-content: space-between; border-bottom: 1px solid black; padding-bottom: 2px;"> <span>V/f</span> <span>DTV</span> <span>PG V/f</span> <span>PG DTV</span> </div> <div style="display: flex; justify-content: space-between; border-bottom: 1px solid black; padding-bottom: 2px;"> <span>SLV</span> <span>PGV</span> <span>PM SLV</span> <span>PM PGV</span> </div> 0.000 to 5.000 s	0.02	Available	s	page 6-26
A44	Speed Control 2 Speed Detection Filter	<div style="display: flex; justify-content: space-between; border-bottom: 1px solid black; padding-bottom: 2px;"> <span>V/f</span> <span>DTV</span> <span>PG V/f</span> <span>PG DTV</span> </div> <div style="display: flex; justify-content: space-between; border-bottom: 1px solid black; padding-bottom: 2px;"> <span>SLV</span> <span>PGV</span> <span>PM SLV</span> <span>PM PGV</span> </div> 0.000 to 0.100 s	0.005	Available	s	page 6-26
A45	Speed Control 2 P Proportional Gain	<div style="display: flex; justify-content: space-between; border-bottom: 1px solid black; padding-bottom: 2px;"> <span>V/f</span> <span>DTV</span> <span>PG V/f</span> <span>PG DTV</span> </div> <div style="display: flex; justify-content: space-between; border-bottom: 1px solid black; padding-bottom: 2px;"> <span>SLV</span> <span>PGV</span> <span>PM SLV</span> <span>PM PGV</span> </div> 0.1 to 200.0	10	Available	-	page 6-26
A46	Speed Control 2 I Integral Time	<div style="display: flex; justify-content: space-between; border-bottom: 1px solid black; padding-bottom: 2px;"> <span>V/f</span> <span>DTV</span> <span>PG V/f</span> <span>PG DTV</span> </div> <div style="display: flex; justify-content: space-between; border-bottom: 1px solid black; padding-bottom: 2px;"> <span>SLV</span> <span>PGV</span> <span>PM SLV</span> <span>PM PGV</span> </div> 0.001 to 9.999 s 999: Cancel integral term	0.1	Available	s	page 6-26
A47	Speed Control 2 FF Gain	<div style="display: flex; justify-content: space-between; border-bottom: 1px solid black; padding-bottom: 2px;"> <span>V/f</span> <span>DTV</span> <span>PG V/f</span> <span>PG DTV</span> </div> <div style="display: flex; justify-content: space-between; border-bottom: 1px solid black; padding-bottom: 2px;"> <span>SLV</span> <span>PGV</span> <span>PM SLV</span> <span>PM PGV</span> </div> 0.00 to 99.99 s	0	Available	s	page 6-26

Parameter No.	Function name	Monitor or Data Range	Default data	Setting during RUN	Unit	Page
A48	Speed Control 2 Output Filter	<input type="checkbox"/> V/f <input type="checkbox"/> DTV <input type="checkbox"/> PG V/f <input type="checkbox"/> PG DTV <input type="checkbox"/> SLV <input type="checkbox"/> PGV <input type="checkbox"/> PM SLV <input type="checkbox"/> PM PGV 0.000 to 0.100 s	0.002	Available	s	page 6-26
A49	Speed Control 2 Notch Filter Resonance Frequency	<input type="checkbox"/> V/f <input type="checkbox"/> DTV <input type="checkbox"/> PG V/f <input type="checkbox"/> PG DTV <input type="checkbox"/> SLV <input type="checkbox"/> PGV <input type="checkbox"/> PM SLV <input type="checkbox"/> PM PGV 1 to 500 Hz	200	Available	Hz	page 6-26
A50	Speed Control 2 Notch Filter Attenuation Level	<input type="checkbox"/> V/f <input type="checkbox"/> DTV <input type="checkbox"/> PG V/f <input type="checkbox"/> PG DTV <input type="checkbox"/> SLV <input type="checkbox"/> PGV <input type="checkbox"/> PM SLV <input type="checkbox"/> PM PGV 0 to 40 dB	0	Available	dB	page 6-26
A51	2nd Cumulative Motor Run Time	<input type="checkbox"/> V/f <input type="checkbox"/> DTV <input type="checkbox"/> PG V/f <input type="checkbox"/> PG DTV <input type="checkbox"/> SLV <input type="checkbox"/> PGV <input type="checkbox"/> PM SLV <input type="checkbox"/> PM PGV 0 to 9,999 (in 10 hours)	0	-	10 hex	page 7-93
A52	2nd Startup Counter for Motor	<input type="checkbox"/> V/f <input type="checkbox"/> DTV <input type="checkbox"/> PG V/f <input type="checkbox"/> PG DTV <input type="checkbox"/> SLV <input type="checkbox"/> PGV <input type="checkbox"/> PM SLV <input type="checkbox"/> PM PGV 0 to 65,535	0	Available	-	page 7-93
A53	2nd Motor 2 %X Correction Factor 1	<input type="checkbox"/> V/f <input type="checkbox"/> DTV <input type="checkbox"/> PG V/f <input type="checkbox"/> PG DTV <input type="checkbox"/> SLV <input type="checkbox"/> PGV <input type="checkbox"/> PM SLV <input type="checkbox"/> PM PGV 0 to 300 %	100	Available	%	page 6-65
A55	Torque Current for 2nd Vector Control	<input type="checkbox"/> V/f <input type="checkbox"/> DTV <input type="checkbox"/> PG V/f <input type="checkbox"/> PG DTV <input type="checkbox"/> SLV <input type="checkbox"/> PGV <input type="checkbox"/> PM SLV <input type="checkbox"/> PM PGV 0.00 to 500.0 A	16.71	-	A	page 6-6
A56	Induced Voltage Factor for 2nd Vector Control	<input type="checkbox"/> V/f <input type="checkbox"/> DTV <input type="checkbox"/> PG V/f <input type="checkbox"/> PG DTV <input type="checkbox"/> SLV <input type="checkbox"/> PGV <input type="checkbox"/> PM SLV <input type="checkbox"/> PM PGV 50 to 100 %	95	-	%	page 6-6
A57	Do not use	-	-	-	-	-
A60	2nd Speed Conversion Coefficient	<input type="checkbox"/> V/f <input type="checkbox"/> DTV <input type="checkbox"/> PG V/f <input type="checkbox"/> PG DTV <input type="checkbox"/> SLV <input type="checkbox"/> PGV <input type="checkbox"/> PM SLV <input type="checkbox"/> PM PGV 0.00: Using E50 value 0.01 to 600.00	0	Available	-	page 6-78 page 7-76
A61	2nd Display Coefficient for Transport time / Auxiliary Display Coefficient for Speed Monitor	<input type="checkbox"/> V/f <input type="checkbox"/> DTV <input type="checkbox"/> PG V/f <input type="checkbox"/> PG DTV <input type="checkbox"/> SLV <input type="checkbox"/> PGV <input type="checkbox"/> PM SLV <input type="checkbox"/> PM PGV 0.000 to 9999	1	Available	-	page 7-76
A62	2nd Starting Frequency Holding Time	<input type="checkbox"/> V/f <input type="checkbox"/> DTV <input type="checkbox"/> PG V/f <input type="checkbox"/> PG DTV <input type="checkbox"/> SLV <input type="checkbox"/> PGV <input type="checkbox"/> PM SLV <input type="checkbox"/> PM PGV 0.00 to 10.00 s	0.00	Available	s	page 7-114

Parameter No.	Function name	Monitor or Data Range	Default data	Setting during RUN	Unit	Page
A63	2nd Stop Frequency	<div style="display: flex; justify-content: space-between; border-bottom: 1px solid black; padding-bottom: 2px;"> <span>V/f</span> <span>DTV</span> <span>PG V/f</span> <span>PG DTV</span> </div> <div style="display: flex; justify-content: space-between; border-bottom: 1px solid black; padding-bottom: 2px;"> <span>SLV</span> <span>PGV</span> <span>PM SLV</span> <span>PM PGV</span> </div> 0.0 to 60.0 Hz 999: According to F025	32767	Available	Hz	page 7-114
A64	2nd Stop Frequency Detection Method Selection	<div style="display: flex; justify-content: space-between; border-bottom: 1px solid black; padding-bottom: 2px;"> <span>V/f</span> <span>DTV</span> <span>PG V/f</span> <span>PG DTV</span> </div> <div style="display: flex; justify-content: space-between; border-bottom: 1px solid black; padding-bottom: 2px;"> <span>SLV</span> <span>PGV</span> <span>PM SLV</span> <span>PM PGV</span> </div> 0: Detected speed 1: Reference speed 100: According to F38	100	-	-	page 7-114
A65	2nd Stop Frequency Holding Time	<div style="display: flex; justify-content: space-between; border-bottom: 1px solid black; padding-bottom: 2px;"> <span>V/f</span> <span>DTV</span> <span>PG V/f</span> <span>PG DTV</span> </div> <div style="display: flex; justify-content: space-between; border-bottom: 1px solid black; padding-bottom: 2px;"> <span>SLV</span> <span>PGV</span> <span>PM SLV</span> <span>PM PGV</span> </div> 0.00 to 10.00 s	0.00	Available	s	page 7-114

### 4-2-7 Parameter b (Speed Control 3)

Parameter No.	Function name	Monitor or Data Range	Default data	Setting during RUN	Unit	Page
b43	Speed Control 3 Speed Command Filter	<div style="display: flex; justify-content: space-between; border-bottom: 1px solid black; padding-bottom: 2px;"> <span>V/f</span> <span>DTV</span> <span>PG V/f</span> <span>PG DTV</span> </div> <div style="display: flex; justify-content: space-between; border-bottom: 1px solid black; padding-bottom: 2px;"> <span>SLV</span> <span>PGV</span> <span>PM SLV</span> <span>PM PGV</span> </div> 0.000 to 5.000 s	0.02	Available	s	page 6-26
b44	Speed Control 3 Speed Detection Filter	<div style="display: flex; justify-content: space-between; border-bottom: 1px solid black; padding-bottom: 2px;"> <span>V/f</span> <span>DTV</span> <span>PG V/f</span> <span>PG DTV</span> </div> <div style="display: flex; justify-content: space-between; border-bottom: 1px solid black; padding-bottom: 2px;"> <span>SLV</span> <span>PGV</span> <span>PM SLV</span> <span>PM PGV</span> </div> 0.000 to 0.100 s	0.005	Available	s	page 6-26
b45	Speed Control 3 P Proportional Gain	<div style="display: flex; justify-content: space-between; border-bottom: 1px solid black; padding-bottom: 2px;"> <span>V/f</span> <span>DTV</span> <span>PG V/f</span> <span>PG DTV</span> </div> <div style="display: flex; justify-content: space-between; border-bottom: 1px solid black; padding-bottom: 2px;"> <span>SLV</span> <span>PGV</span> <span>PM SLV</span> <span>PM PGV</span> </div> 0.1 to 200.0	10	Available	-	page 6-26
b46	Speed Control 3 I Integral Time	<div style="display: flex; justify-content: space-between; border-bottom: 1px solid black; padding-bottom: 2px;"> <span>V/f</span> <span>DTV</span> <span>PG V/f</span> <span>PG DTV</span> </div> <div style="display: flex; justify-content: space-between; border-bottom: 1px solid black; padding-bottom: 2px;"> <span>SLV</span> <span>PGV</span> <span>PM SLV</span> <span>PM PGV</span> </div> 0.001 to 9.999 s 999: Disable	0.1	Available	s	page 6-26
b47	Speed Control 3 FF Gain	<div style="display: flex; justify-content: space-between; border-bottom: 1px solid black; padding-bottom: 2px;"> <span>V/f</span> <span>DTV</span> <span>PG V/f</span> <span>PG DTV</span> </div> <div style="display: flex; justify-content: space-between; border-bottom: 1px solid black; padding-bottom: 2px;"> <span>SLV</span> <span>PGV</span> <span>PM SLV</span> <span>PM PGV</span> </div> 0.00 to 99.99 s	0	Available	s	page 6-26
b48	Speed Control 3 Output Filter	<div style="display: flex; justify-content: space-between; border-bottom: 1px solid black; padding-bottom: 2px;"> <span>V/f</span> <span>DTV</span> <span>PG V/f</span> <span>PG DTV</span> </div> <div style="display: flex; justify-content: space-between; border-bottom: 1px solid black; padding-bottom: 2px;"> <span>SLV</span> <span>PGV</span> <span>PM SLV</span> <span>PM PGV</span> </div> 0.000 to 0.100 s	0.002	Available	s	page 6-26
b49	Speed Control 3 Notch Filter Resonance Frequency	<div style="display: flex; justify-content: space-between; border-bottom: 1px solid black; padding-bottom: 2px;"> <span>V/f</span> <span>DTV</span> <span>PG V/f</span> <span>PG DTV</span> </div> <div style="display: flex; justify-content: space-between; border-bottom: 1px solid black; padding-bottom: 2px;"> <span>SLV</span> <span>PGV</span> <span>PM SLV</span> <span>PM PGV</span> </div> 1 to 500 Hz	200	Available	Hz	page 6-26

Parameter No.	Function name	Monitor or Data Range	Default data	Setting during RUN	Unit	Page
b50	Speed Control 3 Notch Filter Attenuation Level	<input type="checkbox"/> V/f <input type="checkbox"/> DTV <input type="checkbox"/> PG V/f <input type="checkbox"/> PG DTV <input type="checkbox"/> SLV <input type="checkbox"/> PGV <input type="checkbox"/> PM SLV <input type="checkbox"/> PM PGV 0 to 40 dB	0	Available	dB	page 6-26

#### 4-2-8 Parameter r (Speed Control 4)

Parameter No.	Function name	Monitor or Data Range	Default data	Setting during RUN	Unit	Page
r43	Speed Control 4 Speed Command Filter	<input type="checkbox"/> V/f <input type="checkbox"/> DTV <input type="checkbox"/> PG V/f <input type="checkbox"/> PG DTV <input type="checkbox"/> SLV <input type="checkbox"/> PGV <input type="checkbox"/> PM SLV <input type="checkbox"/> PM PGV 0.000 to 5.000 s	0.02	Available	s	page 6-26
r44	Speed Control 4 Speed Detection Filter	<input type="checkbox"/> V/f <input type="checkbox"/> DTV <input type="checkbox"/> PG V/f <input type="checkbox"/> PG DTV <input type="checkbox"/> SLV <input type="checkbox"/> PGV <input type="checkbox"/> PM SLV <input type="checkbox"/> PM PGV 0.000 to 0.100 s	0.005	Available	s	page 6-26
r45	Speed Control 4 P Proportional Gain	<input type="checkbox"/> V/f <input type="checkbox"/> DTV <input type="checkbox"/> PG V/f <input type="checkbox"/> PG DTV <input type="checkbox"/> SLV <input type="checkbox"/> PGV <input type="checkbox"/> PM SLV <input type="checkbox"/> PM PGV 0.1 to 200.0	10	Available	-	page 6-26
r46	Speed Control 4 I Integral Time	<input type="checkbox"/> V/f <input type="checkbox"/> DTV <input type="checkbox"/> PG V/f <input type="checkbox"/> PG DTV <input type="checkbox"/> SLV <input type="checkbox"/> PGV <input type="checkbox"/> PM SLV <input type="checkbox"/> PM PGV 0.001 to 9.999 s 999: Disable	0.1	Available	s	page 6-26
r47	Speed Control 4 FF Gain	<input type="checkbox"/> V/f <input type="checkbox"/> DTV <input type="checkbox"/> PG V/f <input type="checkbox"/> PG DTV <input type="checkbox"/> SLV <input type="checkbox"/> PGV <input type="checkbox"/> PM SLV <input type="checkbox"/> PM PGV 0.00 to 99.99 s	0	Available	s	page 6-26
r48	Speed Control 4 Output Filter	<input type="checkbox"/> V/f <input type="checkbox"/> DTV <input type="checkbox"/> PG V/f <input type="checkbox"/> PG DTV <input type="checkbox"/> SLV <input type="checkbox"/> PGV <input type="checkbox"/> PM SLV <input type="checkbox"/> PM PGV 0.000 to 0.100 s	0.002	Available	s	page 6-26
r49	Speed Control 4 Notch Filter Resonance Frequency	<input type="checkbox"/> V/f <input type="checkbox"/> DTV <input type="checkbox"/> PG V/f <input type="checkbox"/> PG DTV <input type="checkbox"/> SLV <input type="checkbox"/> PGV <input type="checkbox"/> PM SLV <input type="checkbox"/> PM PGV 1 to 500 Hz	200	Available	Hz	page 6-26
r50	Speed Control 4 Notch Filter Attenuation Level	<input type="checkbox"/> V/f <input type="checkbox"/> DTV <input type="checkbox"/> PG V/f <input type="checkbox"/> PG DTV <input type="checkbox"/> SLV <input type="checkbox"/> PGV <input type="checkbox"/> PM SLV <input type="checkbox"/> PM PGV 0 to 40 dB	0	Available	dB	page 6-26

## 4-2-9 Parameter J (Applied Functions 1)

Parameter No.	Function name	Monitor or Data Range	Default data	Setting during RUN	Unit	Page
J01	PID Control Function Selection	<div style="display: flex; justify-content: space-between; border-bottom: 1px solid black; padding-bottom: 2px;"> <span>V/f</span> <span>DTV</span> <span>PG V/f</span> <span>PG DTV</span> </div> <div style="display: flex; justify-content: space-between; border-bottom: 1px solid black; padding-bottom: 2px;"> <span>SLV</span> <span>PGV</span> <span>PM SLV</span> <span>PM PGV</span> </div> 0: Disable 1: Process normal operation 2: Process inverse operation 3: Dancer 4: Process normal operation, opposite operation available 5: Process inverse operation, opposite operation available	0	-	-	page 7-123
J02	PID Control PID Command Selection	<div style="display: flex; justify-content: space-between; border-bottom: 1px solid black; padding-bottom: 2px;"> <span>V/f</span> <span>DTV</span> <span>PG V/f</span> <span>PG DTV</span> </div> <div style="display: flex; justify-content: space-between; border-bottom: 1px solid black; padding-bottom: 2px;"> <span>SLV</span> <span>PGV</span> <span>PM SLV</span> <span>PM PGV</span> </div> 0: Digital Operator (Up/Down keys) 1: Analog input 3: UP/DOWN control 4: RS-485 communications	0	-	-	page 7-123
J03	PID Control P Proportional Gain	<div style="display: flex; justify-content: space-between; border-bottom: 1px solid black; padding-bottom: 2px;"> <span>V/f</span> <span>DTV</span> <span>PG V/f</span> <span>PG DTV</span> </div> <div style="display: flex; justify-content: space-between; border-bottom: 1px solid black; padding-bottom: 2px;"> <span>SLV</span> <span>PGV</span> <span>PM SLV</span> <span>PM PGV</span> </div> 0.000 to 30.000	0.1	Available	-	page 7-123
J04	PID Control I Integral Time	<div style="display: flex; justify-content: space-between; border-bottom: 1px solid black; padding-bottom: 2px;"> <span>V/f</span> <span>DTV</span> <span>PG V/f</span> <span>PG DTV</span> </div> <div style="display: flex; justify-content: space-between; border-bottom: 1px solid black; padding-bottom: 2px;"> <span>SLV</span> <span>PGV</span> <span>PM SLV</span> <span>PM PGV</span> </div> 0.0 to 3600.0 s	0	Available	s	page 7-123
J05	PID Control D Differential Time	<div style="display: flex; justify-content: space-between; border-bottom: 1px solid black; padding-bottom: 2px;"> <span>V/f</span> <span>DTV</span> <span>PG V/f</span> <span>PG DTV</span> </div> <div style="display: flex; justify-content: space-between; border-bottom: 1px solid black; padding-bottom: 2px;"> <span>SLV</span> <span>PGV</span> <span>PM SLV</span> <span>PM PGV</span> </div> 0.00 to 600.00 s	0	Available	s	page 7-123
J06	PID Control Feedback Filter	<div style="display: flex; justify-content: space-between; border-bottom: 1px solid black; padding-bottom: 2px;"> <span>V/f</span> <span>DTV</span> <span>PG V/f</span> <span>PG DTV</span> </div> <div style="display: flex; justify-content: space-between; border-bottom: 1px solid black; padding-bottom: 2px;"> <span>SLV</span> <span>PGV</span> <span>PM SLV</span> <span>PM PGV</span> </div> 0.0 to 900.0 s	0.5	Available	s	page 7-123
J10	PID Control Anti-reset Windup Width	<div style="display: flex; justify-content: space-between; border-bottom: 1px solid black; padding-bottom: 2px;"> <span>V/f</span> <span>DTV</span> <span>PG V/f</span> <span>PG DTV</span> </div> <div style="display: flex; justify-content: space-between; border-bottom: 1px solid black; padding-bottom: 2px;"> <span>SLV</span> <span>PGV</span> <span>PM SLV</span> <span>PM PGV</span> </div> 0 to 200 % Percentage of PID command	200	Available	%	page 7-123

Parameter No.	Function name	Monitor or Data Range	Default data	Setting during RUN	Unit	Page
J11	PID Control Select Warning Output Selection	<div style="display: flex; justify-content: space-between; border-bottom: 1px solid black; padding-bottom: 2px;"> <span>V/f</span> <span>DTV</span> <span>PG V/f</span> <span>PG DTV</span> </div> <div style="display: flex; justify-content: space-between; border-bottom: 1px solid black; padding-bottom: 2px;"> <span>SLV</span> <span>PGV</span> <span>PM SLV</span> <span>PM PGV</span> </div> <p>0: Warning from absolute value                      1: Warning from absolute value with hold                      2: Warning from absolute value with latch                      3: Warning from absolute value with hold and latch                      4: Warning from PID error                      5: Warning from PID error with hold                      6: Warning from PID error with latch                      7: Warning from PID error with hold and latch</p>	0	Available	-	page 7-123
J12	PID Control Upper Limit of Warning (AH)	<div style="display: flex; justify-content: space-between; border-bottom: 1px solid black; padding-bottom: 2px;"> <span>V/f</span> <span>DTV</span> <span>PG V/f</span> <span>PG DTV</span> </div> <div style="display: flex; justify-content: space-between; border-bottom: 1px solid black; padding-bottom: 2px;"> <span>SLV</span> <span>PGV</span> <span>PM SLV</span> <span>PM PGV</span> </div> <p>-100 % to 100 %</p>	100	Available	%	page 7-123
J13	PID Control Lower Limit of Warning (AL)	<div style="display: flex; justify-content: space-between; border-bottom: 1px solid black; padding-bottom: 2px;"> <span>V/f</span> <span>DTV</span> <span>PG V/f</span> <span>PG DTV</span> </div> <div style="display: flex; justify-content: space-between; border-bottom: 1px solid black; padding-bottom: 2px;"> <span>SLV</span> <span>PGV</span> <span>PM SLV</span> <span>PM PGV</span> </div> <p>-100 % to 100 %</p>	0	Available	%	page 7-123
J15	PID Control Sleep Frequency for Process Control	<div style="display: flex; justify-content: space-between; border-bottom: 1px solid black; padding-bottom: 2px;"> <span>V/f</span> <span>DTV</span> <span>PG V/f</span> <span>PG DTV</span> </div> <div style="display: flex; justify-content: space-between; border-bottom: 1px solid black; padding-bottom: 2px;"> <span>SLV</span> <span>PGV</span> <span>PM SLV</span> <span>PM PGV</span> </div> <p>0.0: Disable                      1.0 to 590.0 Hz</p>	0	Available	Hz	page 7-123
J16	PID Control Sleep Timer for Process Control	<div style="display: flex; justify-content: space-between; border-bottom: 1px solid black; padding-bottom: 2px;"> <span>V/f</span> <span>DTV</span> <span>PG V/f</span> <span>PG DTV</span> </div> <div style="display: flex; justify-content: space-between; border-bottom: 1px solid black; padding-bottom: 2px;"> <span>SLV</span> <span>PGV</span> <span>PM SLV</span> <span>PM PGV</span> </div> <p>0 to 60 s</p>	30	Available	s	page 7-123
J17	PID Control Restart Frequency after Stopping for Process Control	<div style="display: flex; justify-content: space-between; border-bottom: 1px solid black; padding-bottom: 2px;"> <span>V/f</span> <span>DTV</span> <span>PG V/f</span> <span>PG DTV</span> </div> <div style="display: flex; justify-content: space-between; border-bottom: 1px solid black; padding-bottom: 2px;"> <span>SLV</span> <span>PGV</span> <span>PM SLV</span> <span>PM PGV</span> </div> <p>0.0 to 590.0 Hz</p>	0	Available	Hz	page 7-123
J18	PID Control PID Output Upper Limit	<div style="display: flex; justify-content: space-between; border-bottom: 1px solid black; padding-bottom: 2px;"> <span>V/f</span> <span>DTV</span> <span>PG V/f</span> <span>PG DTV</span> </div> <div style="display: flex; justify-content: space-between; border-bottom: 1px solid black; padding-bottom: 2px;"> <span>SLV</span> <span>PGV</span> <span>PM SLV</span> <span>PM PGV</span> </div> <p>-150 to 150 %                      999: Depends on setting of F15</p>	32767	Available	%	page 7-123
J19	PID Control PID Output Lower Limit	<div style="display: flex; justify-content: space-between; border-bottom: 1px solid black; padding-bottom: 2px;"> <span>V/f</span> <span>DTV</span> <span>PG V/f</span> <span>PG DTV</span> </div> <div style="display: flex; justify-content: space-between; border-bottom: 1px solid black; padding-bottom: 2px;"> <span>SLV</span> <span>PGV</span> <span>PM SLV</span> <span>PM PGV</span> </div> <p>-150 to 150 %                      999: Depends on setting of F16</p>	32767	Available	%	page 7-123

Parameter No.	Function name	Monitor or Data Range	Default data	Setting during RUN	Unit	Page
J23	PID Control Restart Feedback Deviation after Stopping for Process Control	<input type="checkbox"/> V/f <input type="checkbox"/> DTV <input type="checkbox"/> PG V/f <input type="checkbox"/> PG DTV <input type="checkbox"/> SLV <input type="checkbox"/> PGV <input type="checkbox"/> PM SLV <input type="checkbox"/> PM PGV 0.0 to 100.0 %	0	Available	%	page 7-123
J24	PID Control Restart Delay Time after Stopping for Process Control	<input type="checkbox"/> V/f <input type="checkbox"/> DTV <input type="checkbox"/> PG V/f <input type="checkbox"/> PG DTV <input type="checkbox"/> SLV <input type="checkbox"/> PGV <input type="checkbox"/> PM SLV <input type="checkbox"/> PM PGV 0 to 3600 s	0	Available	s	page 7-123
J57	PID Control Operator PID Reference Position for Dancer	<input type="checkbox"/> V/f <input type="checkbox"/> DTV <input type="checkbox"/> PG V/f <input type="checkbox"/> PG DTV <input type="checkbox"/> SLV <input type="checkbox"/> PGV <input type="checkbox"/> PM SLV <input type="checkbox"/> PM PGV -100 to 0 to 100 %	0	Available	%	page 7-123
J58	PID Control PID Reference Position Detection Width for Dancer	<input type="checkbox"/> V/f <input type="checkbox"/> DTV <input type="checkbox"/> PG V/f <input type="checkbox"/> PG DTV <input type="checkbox"/> SLV <input type="checkbox"/> PGV <input type="checkbox"/> PM SLV <input type="checkbox"/> PM PGV 0: Disable switching PID constant 1 to 100 % (Manually set value)	0	Available	%	page 7-123
J59	PID Control P Gain 2	<input type="checkbox"/> V/f <input type="checkbox"/> DTV <input type="checkbox"/> PG V/f <input type="checkbox"/> PG DTV <input type="checkbox"/> SLV <input type="checkbox"/> PGV <input type="checkbox"/> PM SLV <input type="checkbox"/> PM PGV 0.000 to 30.000	0.1	Available	-	page 7-123
J60	PID Control I Integral Time 2	<input type="checkbox"/> V/f <input type="checkbox"/> DTV <input type="checkbox"/> PG V/f <input type="checkbox"/> PG DTV <input type="checkbox"/> SLV <input type="checkbox"/> PGV <input type="checkbox"/> PM SLV <input type="checkbox"/> PM PGV 0.0 to 3600.0 s	0	Available	s	page 7-123
J61	PID Control D Differential Time 2	<input type="checkbox"/> V/f <input type="checkbox"/> DTV <input type="checkbox"/> PG V/f <input type="checkbox"/> PG DTV <input type="checkbox"/> SLV <input type="checkbox"/> PGV <input type="checkbox"/> PM SLV <input type="checkbox"/> PM PGV 0.00 to 600.00 s	0	Available	s	page 7-123
J62	PID Control Block Selection	<input type="checkbox"/> V/f <input type="checkbox"/> DTV <input type="checkbox"/> PG V/f <input type="checkbox"/> PG DTV <input type="checkbox"/> SLV <input type="checkbox"/> PGV <input type="checkbox"/> PM SLV <input type="checkbox"/> PM PGV Bit1: PID output ratio selection 0: Ratio to frequency command 1: Ratio to maximum frequency Bit0: PID output polarity selection 0: Plus (Addition) 1: Minus (Subtraction)	0	-	-	page 7-123
J63	Overload Stop Item Selection	<input type="checkbox"/> V/f <input type="checkbox"/> DTV <input type="checkbox"/> PG V/f <input type="checkbox"/> PG DTV <input type="checkbox"/> SLV <input type="checkbox"/> PGV <input type="checkbox"/> PM SLV <input type="checkbox"/> PM PGV 0: Torque 1: Current	0	Available	-	page 7-153

Parameter No.	Function name	Monitor or Data Range	Default data	Setting during RUN	Unit	Page
J64	Overload Stop Detection Level	<div style="display: flex; justify-content: space-between; font-size: small;"> <span>V/f</span> <span>DTV</span> <span>PG V/f</span> <span>PG DTV</span> </div> <div style="display: flex; justify-content: space-between; font-size: small;"> <span>SLV</span> <span>PGV</span> <span>PM SLV</span> <span>PM PGV</span> </div> 20 to 200%	100	Available	%	page 7-153
J65	Overload Stop Mode Selection	<div style="display: flex; justify-content: space-between; font-size: small;"> <span>V/f</span> <span>DTV</span> <span>PG V/f</span> <span>PG DTV</span> </div> <div style="display: flex; justify-content: space-between; font-size: small;"> <span>SLV</span> <span>PGV</span> <span>PM SLV</span> <span>PM PGV</span> </div> 0: Disable 1: Deceleration stop 2: Free run stop 3: Mechanical stop	0	-	-	page 7-153
J66	Overload Stop Operation Mode	<div style="display: flex; justify-content: space-between; font-size: small;"> <span>V/f</span> <span>DTV</span> <span>PG V/f</span> <span>PG DTV</span> </div> <div style="display: flex; justify-content: space-between; font-size: small;"> <span>SLV</span> <span>PGV</span> <span>PM SLV</span> <span>PM PGV</span> </div> 0: During constant speed running and deceleration 1: During constant speed running 2: Anytime	0	Available	-	page 7-153
J67	Overload Stop Detection Timer	<div style="display: flex; justify-content: space-between; font-size: small;"> <span>V/f</span> <span>DTV</span> <span>PG V/f</span> <span>PG DTV</span> </div> <div style="display: flex; justify-content: space-between; font-size: small;"> <span>SLV</span> <span>PGV</span> <span>PM SLV</span> <span>PM PGV</span> </div> 0.00 to 600.00 s	0	Available	s	page 7-153
J68	Brake Control Brake-release Current	<div style="display: flex; justify-content: space-between; font-size: small;"> <span>V/f</span> <span>DTV</span> <span>PG V/f</span> <span>PG DTV</span> </div> <div style="display: flex; justify-content: space-between; font-size: small;"> <span>SLV</span> <span>PGV</span> <span>PM SLV</span> <span>PM PGV</span> </div> 0.00 to 300.00 %	100.00	Available	%	page 6-76
J69	Brake Control Brake-release Frequency	<div style="display: flex; justify-content: space-between; font-size: small;"> <span>V/f</span> <span>DTV</span> <span>PG V/f</span> <span>PG DTV</span> </div> <div style="display: flex; justify-content: space-between; font-size: small;"> <span>SLV</span> <span>PGV</span> <span>PM SLV</span> <span>PM PGV</span> </div> 0.0 to 25.0 Hz	1.0	Available	Hz	page 6-76
J70	Brake Control Brake-release Timer	<div style="display: flex; justify-content: space-between; font-size: small;"> <span>V/f</span> <span>DTV</span> <span>PG V/f</span> <span>PG DTV</span> </div> <div style="display: flex; justify-content: space-between; font-size: small;"> <span>SLV</span> <span>PGV</span> <span>PM SLV</span> <span>PM PGV</span> </div> 0.000 to 5.000 s	1.000	Available	s	page 6-76
J71	Brake Control Brake-applied Frequency	<div style="display: flex; justify-content: space-between; font-size: small;"> <span>V/f</span> <span>DTV</span> <span>PG V/f</span> <span>PG DTV</span> </div> <div style="display: flex; justify-content: space-between; font-size: small;"> <span>SLV</span> <span>PGV</span> <span>PM SLV</span> <span>PM PGV</span> </div> 0.0 to 25.0 Hz	1.0	Available	Hz	page 6-76
J72	Brake Control Brake-applied Timer	<div style="display: flex; justify-content: space-between; font-size: small;"> <span>V/f</span> <span>DTV</span> <span>PG V/f</span> <span>PG DTV</span> </div> <div style="display: flex; justify-content: space-between; font-size: small;"> <span>SLV</span> <span>PGV</span> <span>PM SLV</span> <span>PM PGV</span> </div> 0.000 to 5.000 s	1.000	Available	s	page 6-76
J90	Overload Stop Function P gain	<div style="display: flex; justify-content: space-between; font-size: small;"> <span>V/f</span> <span>DTV</span> <span>PG V/f</span> <span>PG DTV</span> </div> <div style="display: flex; justify-content: space-between; font-size: small;"> <span>SLV</span> <span>PGV</span> <span>PM SLV</span> <span>PM PGV</span> </div> 0.000 to 2.000 times 999: 0.050 times	32767	Available	-	page 7-153



Parameter No.	Function name	Monitor or Data Range	Default data	Setting during RUN	Unit	Page
J91	Overload Stop Function Integral time	<div style="display: flex; justify-content: space-between; border: 1px solid black; padding: 2px;"> <span>V/f</span> <span>DTV</span> <span>PG V/f</span> <span>PG DTV</span> </div> <div style="display: flex; justify-content: space-between; border: 1px solid black; padding: 2px; margin-top: 2px;"> <span>SLV</span> <span>PGV</span> <span>PM SLV</span> <span>PM PGV</span> </div> 0.001 to 9.999 s 999: 0.025 s	32767	Available	s	page 7-153
J92	Overload Stop Function Current level	<div style="display: flex; justify-content: space-between; border: 1px solid black; padding: 2px;"> <span>V/f</span> <span>DTV</span> <span>PG V/f</span> <span>PG DTV</span> </div> <div style="display: flex; justify-content: space-between; border: 1px solid black; padding: 2px; margin-top: 2px;"> <span>SLV</span> <span>PGV</span> <span>PM SLV</span> <span>PM PGV</span> </div> 50.0% to 150.0%	100	Available	%	page 7-153
J95	Brake control Brake-release Torque	<div style="display: flex; justify-content: space-between; border: 1px solid black; padding: 2px;"> <span>V/f</span> <span>DTV</span> <span>PG V/f</span> <span>PG DTV</span> </div> <div style="display: flex; justify-content: space-between; border: 1px solid black; padding: 2px; margin-top: 2px;"> <span>SLV</span> <span>PGV</span> <span>PM SLV</span> <span>PM PGV</span> </div> 0.00 to 300.00 %	100	Available	%	page 6-76
J96	Brake Control Operation Selection	<div style="display: flex; justify-content: space-between; border: 1px solid black; padding: 2px;"> <span>V/f</span> <span>DTV</span> <span>PG V/f</span> <span>PG DTV</span> </div> <div style="display: flex; justify-content: space-between; border: 1px solid black; padding: 2px; margin-top: 2px;"> <span>SLV</span> <span>PGV</span> <span>PM SLV</span> <span>PM PGV</span> </div> Bit6: Stop condition at Position control 0: BRK OFF 1: BRK ON Bit4: Brake-applied condition 0: Disable RUN command "OFF" 1: Enable RUN command "OFF" Bit3 to 1: Reserved Bit0: Speed detection/Speed command 0: Speed detection 1: Speed command	0	Available	-	page 6-76
J97	Servo Lock Gain	<div style="display: flex; justify-content: space-between; border: 1px solid black; padding: 2px;"> <span>V/f</span> <span>DTV</span> <span>PG V/f</span> <span>PG DTV</span> </div> <div style="display: flex; justify-content: space-between; border: 1px solid black; padding: 2px; margin-top: 2px;"> <span>SLV</span> <span>PGV</span> <span>PM SLV</span> <span>PM PGV</span> </div> 0.000 to 9.999	0.01	Available	-	page 7-148
J98	Servo Lock Completion Timer	<div style="display: flex; justify-content: space-between; border: 1px solid black; padding: 2px;"> <span>V/f</span> <span>DTV</span> <span>PG V/f</span> <span>PG DTV</span> </div> <div style="display: flex; justify-content: space-between; border: 1px solid black; padding: 2px; margin-top: 2px;"> <span>SLV</span> <span>PGV</span> <span>PM SLV</span> <span>PM PGV</span> </div> 0.000 to 1.000 s	0.1	Available	s	page 7-148
J99	Servo Lock Completion Range	<div style="display: flex; justify-content: space-between; border: 1px solid black; padding: 2px;"> <span>V/f</span> <span>DTV</span> <span>PG V/f</span> <span>PG DTV</span> </div> <div style="display: flex; justify-content: space-between; border: 1px solid black; padding: 2px; margin-top: 2px;"> <span>SLV</span> <span>PGV</span> <span>PM SLV</span> <span>PM PGV</span> </div> 0 to 9999	10	Available	-	page 7-148
J105	Do not use	-	-	-	-	-
J106	PID Control Maximum Scale	<div style="display: flex; justify-content: space-between; border: 1px solid black; padding: 2px;"> <span>V/f</span> <span>DTV</span> <span>PG V/f</span> <span>PG DTV</span> </div> <div style="display: flex; justify-content: space-between; border: 1px solid black; padding: 2px; margin-top: 2px;"> <span>SLV</span> <span>PGV</span> <span>PM SLV</span> <span>PM PGV</span> </div> -999.00 to 0.00 to 9990.00	100	-	-	page 7-123
J107	PID Control Minimum Scale	<div style="display: flex; justify-content: space-between; border: 1px solid black; padding: 2px;"> <span>V/f</span> <span>DTV</span> <span>PG V/f</span> <span>PG DTV</span> </div> <div style="display: flex; justify-content: space-between; border: 1px solid black; padding: 2px; margin-top: 2px;"> <span>SLV</span> <span>PGV</span> <span>PM SLV</span> <span>PM PGV</span> </div> -999.00 to 0.00 to 9990.00	0	-	-	page 7-123

Parameter No.	Function name	Monitor or Data Range	Default data	Setting during RUN	Unit	Page
J136	PID Control Multistep PID Command 1	<div style="display: flex; justify-content: space-between; border-bottom: 1px solid black; padding-bottom: 2px;"> <span>V/f</span> <span>DTV</span> <span>PG V/f</span> <span>PG DTV</span> </div> <div style="display: flex; justify-content: space-between; border-bottom: 1px solid black; padding-bottom: 2px;"> <span>SLV</span> <span>PGV</span> <span>PM SLV</span> <span>PM PGV</span> </div> <p>-999.00 to 0.00 to 9990.00</p>	0	Available	-	page 7-123
J137	PID Control Multistep PID Command 2	<div style="display: flex; justify-content: space-between; border-bottom: 1px solid black; padding-bottom: 2px;"> <span>V/f</span> <span>DTV</span> <span>PG V/f</span> <span>PG DTV</span> </div> <div style="display: flex; justify-content: space-between; border-bottom: 1px solid black; padding-bottom: 2px;"> <span>SLV</span> <span>PGV</span> <span>PM SLV</span> <span>PM PGV</span> </div> <p>-999.00 to 0.00 to 9990.00</p>	0	Available	-	page 7-123
J138	PID Control Multistep PID Command 3	<div style="display: flex; justify-content: space-between; border-bottom: 1px solid black; padding-bottom: 2px;"> <span>V/f</span> <span>DTV</span> <span>PG V/f</span> <span>PG DTV</span> </div> <div style="display: flex; justify-content: space-between; border-bottom: 1px solid black; padding-bottom: 2px;"> <span>SLV</span> <span>PGV</span> <span>PM SLV</span> <span>PM PGV</span> </div> <p>-999.00 to 0.00 to 9990.00</p>	0	Available	-	page 7-123

#### 4-2-10 Parameter d (Applied Functions 2)

Parameter No.	Function name	Monitor or Data Range	Default data	Setting during RUN	Unit	Page
d01	Speed Control 1 Speed Command Filter	<div style="display: flex; justify-content: space-between; border-bottom: 1px solid black; padding-bottom: 2px;"> <span>V/f</span> <span>DTV</span> <span>PG V/f</span> <span>PG DTV</span> </div> <div style="display: flex; justify-content: space-between; border-bottom: 1px solid black; padding-bottom: 2px;"> <span>SLV</span> <span>PGV</span> <span>PM SLV</span> <span>PM PGV</span> </div> <p>0.000 to 5.000 s</p>	0.02	Available	s	page 6-26
d02	Speed Control 1 Speed Detection Filter	<div style="display: flex; justify-content: space-between; border-bottom: 1px solid black; padding-bottom: 2px;"> <span>V/f</span> <span>DTV</span> <span>PG V/f</span> <span>PG DTV</span> </div> <div style="display: flex; justify-content: space-between; border-bottom: 1px solid black; padding-bottom: 2px;"> <span>SLV</span> <span>PGV</span> <span>PM SLV</span> <span>PM PGV</span> </div> <p>0.000 to 0.100 s</p>	0.005	Available	s	page 6-26
d03	Speed Control 1 P Proportional Gain	<div style="display: flex; justify-content: space-between; border-bottom: 1px solid black; padding-bottom: 2px;"> <span>V/f</span> <span>DTV</span> <span>PG V/f</span> <span>PG DTV</span> </div> <div style="display: flex; justify-content: space-between; border-bottom: 1px solid black; padding-bottom: 2px;"> <span>SLV</span> <span>PGV</span> <span>PM SLV</span> <span>PM PGV</span> </div> <p>0.1 to 200.0</p>	10	Available	-	page 6-26
d04	Speed Control 1 I Integral Time	<div style="display: flex; justify-content: space-between; border-bottom: 1px solid black; padding-bottom: 2px;"> <span>V/f</span> <span>DTV</span> <span>PG V/f</span> <span>PG DTV</span> </div> <div style="display: flex; justify-content: space-between; border-bottom: 1px solid black; padding-bottom: 2px;"> <span>SLV</span> <span>PGV</span> <span>PM SLV</span> <span>PM PGV</span> </div> <p>0.001 to 9.999 s 999: Cancel integral term</p>	0.1	Available	s	page 6-26
d05	Speed Control 1 FF Gain	<div style="display: flex; justify-content: space-between; border-bottom: 1px solid black; padding-bottom: 2px;"> <span>V/f</span> <span>DTV</span> <span>PG V/f</span> <span>PG DTV</span> </div> <div style="display: flex; justify-content: space-between; border-bottom: 1px solid black; padding-bottom: 2px;"> <span>SLV</span> <span>PGV</span> <span>PM SLV</span> <span>PM PGV</span> </div> <p>0.00 to 99.99 s</p>	0	Available	s	page 6-26
d06	Speed Control 1 Out- put Filter	<div style="display: flex; justify-content: space-between; border-bottom: 1px solid black; padding-bottom: 2px;"> <span>V/f</span> <span>DTV</span> <span>PG V/f</span> <span>PG DTV</span> </div> <div style="display: flex; justify-content: space-between; border-bottom: 1px solid black; padding-bottom: 2px;"> <span>SLV</span> <span>PGV</span> <span>PM SLV</span> <span>PM PGV</span> </div> <p>0.000 to 0.100 s</p>	0.002	Available	s	page 6-26
d07	Speed Control 1 Notch Filter Resonance Fre- quency	<div style="display: flex; justify-content: space-between; border-bottom: 1px solid black; padding-bottom: 2px;"> <span>V/f</span> <span>DTV</span> <span>PG V/f</span> <span>PG DTV</span> </div> <div style="display: flex; justify-content: space-between; border-bottom: 1px solid black; padding-bottom: 2px;"> <span>SLV</span> <span>PGV</span> <span>PM SLV</span> <span>PM PGV</span> </div> <p>1 to 500 Hz</p>	200	Available	Hz	page 6-26

Parameter No.	Function name	Monitor or Data Range	Default data	Setting during RUN	Unit	Page
d08	Speed Control 1 Notch Filter Attenuation Level	<div style="display: flex; justify-content: space-between;"> <span>V/f</span> <span>DTV</span> <span>PG V/f</span> <span>PG DTV</span> </div> <div style="display: flex; justify-content: space-between;"> <span>SLV</span> <span>PGV</span> <span>PM SLV</span> <span>PM PGV</span> </div> 0 to 40 dB	0	Available	dB	page 6-26
d09	Speed Control Jogging Speed Command Filter	<div style="display: flex; justify-content: space-between;"> <span>V/f</span> <span>DTV</span> <span>PG V/f</span> <span>PG DTV</span> </div> <div style="display: flex; justify-content: space-between;"> <span>SLV</span> <span>PGV</span> <span>PM SLV</span> <span>PM PGV</span> </div> 0.000 to 5.000 s	0.02	Available	s	page 5-60
d10	Speed Control Jogging Speed Detection Filter	<div style="display: flex; justify-content: space-between;"> <span>V/f</span> <span>DTV</span> <span>PG V/f</span> <span>PG DTV</span> </div> <div style="display: flex; justify-content: space-between;"> <span>SLV</span> <span>PGV</span> <span>PM SLV</span> <span>PM PGV</span> </div> 0.000 to 0.100 s	0.005	Available	s	page 5-60
d11	Speed Control Jogging P Proportional Gain	<div style="display: flex; justify-content: space-between;"> <span>V/f</span> <span>DTV</span> <span>PG V/f</span> <span>PG DTV</span> </div> <div style="display: flex; justify-content: space-between;"> <span>SLV</span> <span>PGV</span> <span>PM SLV</span> <span>PM PGV</span> </div> 0.1 to 200.0	10	Available	-	page 5-60
d12	Speed Control Jogging I Integral Time	<div style="display: flex; justify-content: space-between;"> <span>V/f</span> <span>DTV</span> <span>PG V/f</span> <span>PG DTV</span> </div> <div style="display: flex; justify-content: space-between;"> <span>SLV</span> <span>PGV</span> <span>PM SLV</span> <span>PM PGV</span> </div> 0.001 to 9.999 s 999: Cancel integral term	0.1	Available	s	page 5-60
d13	Speed Control Jogging Output Filter	<div style="display: flex; justify-content: space-between;"> <span>V/f</span> <span>DTV</span> <span>PG V/f</span> <span>PG DTV</span> </div> <div style="display: flex; justify-content: space-between;"> <span>SLV</span> <span>PGV</span> <span>PM SLV</span> <span>PM PGV</span> </div> 0.000 to 0.100 s	0.002	Available	s	page 5-60
d14	Input Terminal [PIA] [PIB] Pulse Input Format Selection	<div style="display: flex; justify-content: space-between;"> <span>V/f</span> <span>DTV</span> <span>PG V/f</span> <span>PG DTV</span> </div> <div style="display: flex; justify-content: space-between;"> <span>SLV</span> <span>PGV</span> <span>PM SLV</span> <span>PM PGV</span> </div> 0: Pulse train signing/pulse train input 1: Forward/reverse rotation pulse 2: Quadrature A/B signal (B phase lead) 3: Quadrature A/B signal (A phase lead)	2	-	-	page 6-11 page 7-145
d15	Input Terminal [PIA] [PIB] Encoder Pulse Resolution	<div style="display: flex; justify-content: space-between;"> <span>V/f</span> <span>DTV</span> <span>PG V/f</span> <span>PG DTV</span> </div> <div style="display: flex; justify-content: space-between;"> <span>SLV</span> <span>PGV</span> <span>PM SLV</span> <span>PM PGV</span> </div> 20 to 60000	1024	-	-	page 6-11 page 7-145
d16	Input Terminal [PIA] [PIB] Pulse Scaling Factor Denominator	<div style="display: flex; justify-content: space-between;"> <span>V/f</span> <span>DTV</span> <span>PG V/f</span> <span>PG DTV</span> </div> <div style="display: flex; justify-content: space-between;"> <span>SLV</span> <span>PGV</span> <span>PM SLV</span> <span>PM PGV</span> </div> 1 to 32767	1	Available	-	page 6-11 page 7-145
d17	Input Terminal [PIA] [PIB] Pulse Scaling Factor Numerator	<div style="display: flex; justify-content: space-between;"> <span>V/f</span> <span>DTV</span> <span>PG V/f</span> <span>PG DTV</span> </div> <div style="display: flex; justify-content: space-between;"> <span>SLV</span> <span>PGV</span> <span>PM SLV</span> <span>PM PGV</span> </div> 1 to 32767	1	Available	-	page 6-11 page 7-145

Parameter No.	Function name	Monitor or Data Range	Default data	Setting during RUN	Unit	Page
d18	Input Terminal [PIA] [PIB] Pulse Train Filter Time Constant	<div style="display: flex; justify-content: space-between;"> <span>V/f</span> <span>DTV</span> <span>PG V/f</span> <span>PG DTV</span> </div> <div style="display: flex; justify-content: space-between;"> <span>SLV</span> <span>PGV</span> <span>PM SLV</span> <span>PM PGV</span> </div> <p>0.000 to 5.000 s</p>	0.005	Available	s	page 7-145
d21	Speed Agreement / Speed Deviation Error Hysteresis Width	<div style="display: flex; justify-content: space-between;"> <span>V/f</span> <span>DTV</span> <span>PG V/f</span> <span>PG DTV</span> </div> <div style="display: flex; justify-content: space-between;"> <span>SLV</span> <span>PGV</span> <span>PM SLV</span> <span>PM PGV</span> </div> <p>0.0 to 50.0 %</p>	10	Available	%	page 6-12
d22	Speed Agreement / Speed Deviation Error Detection Timer	<div style="display: flex; justify-content: space-between;"> <span>V/f</span> <span>DTV</span> <span>PG V/f</span> <span>PG DTV</span> </div> <div style="display: flex; justify-content: space-between;"> <span>SLV</span> <span>PGV</span> <span>PM SLV</span> <span>PM PGV</span> </div> <p>0.00 to 10.00 s</p>	0.5	Available	s	page 6-12
d23	Speed Deviation Error Processing Selection	<div style="display: flex; justify-content: space-between;"> <span>V/f</span> <span>DTV</span> <span>PG V/f</span> <span>PG DTV</span> </div> <div style="display: flex; justify-content: space-between;"> <span>SLV</span> <span>PGV</span> <span>PM SLV</span> <span>PM PGV</span> </div> <p>0: Continue to run 1 1: Stop with alarm 1 2: Stop with alarm 2 3: Continue to run 2 4: Stop with alarm 3 5: Stop with alarm 4</p>	2	-	-	page 6-12
d24	Zero Speed Control	<div style="display: flex; justify-content: space-between;"> <span>V/f</span> <span>DTV</span> <span>PG V/f</span> <span>PG DTV</span> </div> <div style="display: flex; justify-content: space-between;"> <span>SLV</span> <span>PGV</span> <span>PM SLV</span> <span>PM PGV</span> </div> <p>0: Disable at startup, enable at stop 1: Enable at startup, enable at stop 2: Disable at startup, disable at stop</p>	0	-	-	page 7-115
d25	Speed Control Speed Loop Switching Time at Parameter Change	<div style="display: flex; justify-content: space-between;"> <span>V/f</span> <span>DTV</span> <span>PG V/f</span> <span>PG DTV</span> </div> <div style="display: flex; justify-content: space-between;"> <span>SLV</span> <span>PGV</span> <span>PM SLV</span> <span>PM PGV</span> </div> <p>0.000 to 1.000 s</p>	0	Available	s	page 6-26
d32	Speed Limit 1 in Forward	<div style="display: flex; justify-content: space-between;"> <span>V/f</span> <span>DTV</span> <span>PG V/f</span> <span>PG DTV</span> </div> <div style="display: flex; justify-content: space-between;"> <span>SLV</span> <span>PGV</span> <span>PM SLV</span> <span>PM PGV</span> </div> <p>0 to 110 %</p>	100	Available	%	page 6-12
d33	Speed Limit 2 in Reverse	<div style="display: flex; justify-content: space-between;"> <span>V/f</span> <span>DTV</span> <span>PG V/f</span> <span>PG DTV</span> </div> <div style="display: flex; justify-content: space-between;"> <span>SLV</span> <span>PGV</span> <span>PM SLV</span> <span>PM PGV</span> </div> <p>0 to 110 %</p>	100	Available	%	page 6-12
d35	Over Speed Detection Level	<div style="display: flex; justify-content: space-between;"> <span>V/f</span> <span>DTV</span> <span>PG V/f</span> <span>PG DTV</span> </div> <div style="display: flex; justify-content: space-between;"> <span>SLV</span> <span>PGV</span> <span>PM SLV</span> <span>PM PGV</span> </div> <p>0 to 120% 999: Depend on d032 and d033</p>	32767	Available	%	page 6-12

Parameter No.	Function name	Monitor or Data Range	Default data	Setting during RUN	Unit	Page
d41	Special Control Selection	<div style="display: flex; justify-content: space-between; font-size: small;"> <span>V/f</span> <span>DTV</span> <span>PG V/f</span> <span>PG DTV</span> </div> <div style="display: flex; justify-content: space-between; font-size: small;"> <span>SLV</span> <span>PGV</span> <span>PM SLV</span> <span>PM PGV</span> </div> <p>0: Disable (Normal control)            1: Enable (Peripheral speed constant control)            2: Do not use            3: Do not use            4: Do not use</p>	0	-	-	page 6-78
d51	Do not use	-	-	-	-	-
d52	Do not use	-	-	-	-	-
d55	Do not use	-	-	-	-	-
d67	Motor Starting Mode Auto Search in Speed Sensor Vector Control	<div style="display: flex; justify-content: space-between; font-size: small;"> <span>V/f</span> <span>DTV</span> <span>PG V/f</span> <span>PG DTV</span> </div> <div style="display: flex; justify-content: space-between; font-size: small;"> <span>SLV</span> <span>PGV</span> <span>PM SLV</span> <span>PM PGV</span> </div> <p>0: Disable            1: Enable (Only at restart after momentary power failure)            2: Enable (At normal start and restart after momentary power failure)</p>	1	-	-	page 7-49
d68	Do not use	-	-	-	-	-
d70	Speed Control Slip Frequency Limit	<div style="display: flex; justify-content: space-between; font-size: small;"> <span>V/f</span> <span>DTV</span> <span>PG V/f</span> <span>PG DTV</span> </div> <div style="display: flex; justify-content: space-between; font-size: small;"> <span>SLV</span> <span>PGV</span> <span>PM SLV</span> <span>PM PGV</span> </div> <p>0.00 to 100.00 %</p>	100	Available	%	page 6-14
d71	Do not use	-	-	-	-	-
d72	Do not use	-	-	-	-	-
d73	Do not use	-	-	-	-	-
d74	Do not use	-	-	-	-	-
d75	Do not use	-	-	-	-	-
d76	Do not use	-	-	-	-	-
d77	Do not use	-	-	-	-	-
d78	Do not use	-	-	-	-	-
d79	Do not use	-	-	-	-	-
d80	1st PM Motor Magnetic Pole Position Pull-in Frequency	<div style="display: flex; justify-content: space-between; font-size: small;"> <span>V/f</span> <span>DTV</span> <span>PG V/f</span> <span>PG DTV</span> </div> <div style="display: flex; justify-content: space-between; font-size: small;"> <span>SLV</span> <span>PGV</span> <span>PM SLV</span> <span>PM PGV</span> </div> <p>0.1 to 10.0Hz</p>	1	Available	Hz	page 6-65
d81	Do not use	-	-	-	-	-
d82	Magnetic Flux Weakening Control Function Selection	<div style="display: flex; justify-content: space-between; font-size: small;"> <span>V/f</span> <span>DTV</span> <span>PG V/f</span> <span>PG DTV</span> </div> <div style="display: flex; justify-content: space-between; font-size: small;"> <span>SLV</span> <span>PGV</span> <span>PM SLV</span> <span>PM PGV</span> </div> <p>0: Disable            1: Enable</p>	1	Available	-	page 6-16
d83	Magnetic Flux Weakening Lower Limit	<div style="display: flex; justify-content: space-between; font-size: small;"> <span>V/f</span> <span>DTV</span> <span>PG V/f</span> <span>PG DTV</span> </div> <div style="display: flex; justify-content: space-between; font-size: small;"> <span>SLV</span> <span>PGV</span> <span>PM SLV</span> <span>PM PGV</span> </div> <p>10 to 70%</p>	40	Available	%	page 6-16

Parameter No.	Function name	Monitor or Data Range	Default data	Setting during RUN	Unit	Page
d84	Do not use	-	-	-	-	-
d85	Do not use	-	-	-	-	-
d86	Acc/Dec Output Frequency Filter	<div style="display: flex; justify-content: space-between; font-size: small;"> <span>V/f</span> <span>DTV</span> <span>PG V/f</span> <span>PG DTV</span> </div> <div style="display: flex; justify-content: space-between; font-size: small;"> <span>SLV</span> <span>PGV</span> <span>PM SLV</span> <span>PM PGV</span> </div> 0.000 to 5.000 s	0	Available	s	page 5-39
d88	Do not use	-	-	-	-	-
d89	PM Motor High-efficiency Control Selection	<div style="display: flex; justify-content: space-between; font-size: small;"> <span>V/f</span> <span>DTV</span> <span>PG V/f</span> <span>PG DTV</span> </div> <div style="display: flex; justify-content: space-between; font-size: small;"> <span>SLV</span> <span>PGV</span> <span>PM SLV</span> <span>PM PGV</span> </div> 0: Disable 1: Enable	1	-	-	page 6-22
d90	Magnetic Flux Level during Deceleration	<div style="display: flex; justify-content: space-between; font-size: small;"> <span>V/f</span> <span>DTV</span> <span>PG V/f</span> <span>PG DTV</span> </div> <div style="display: flex; justify-content: space-between; font-size: small;"> <span>SLV</span> <span>PGV</span> <span>PM SLV</span> <span>PM PGV</span> </div> 100 to 300 %	120	Available	%	page 7-121
d91	Do not use	-	-	-	-	-
d92	Do not use	-	-	-	-	-
d93	Do not use	-	-	-	-	-
d94	Do not use	-	-	-	-	-
d95	Do not use	-	-	-	-	-
d96	Do not use	-	-	-	-	-
d97	Do not use	-	-	-	-	-
d98	Do not use	-	-	-	-	-
d99	Extension Function 1	<div style="display: flex; justify-content: space-between; font-size: small;"> <span>V/f</span> <span>DTV</span> <span>PG V/f</span> <span>PG DTV</span> </div> <div style="display: flex; justify-content: space-between; font-size: small;"> <span>SLV</span> <span>PGV</span> <span>PM SLV</span> <span>PM PGV</span> </div> Bit 3: Jogging Enable via communications Do not use other bits	8	Available	-	page 5-60
d190	Do not use	-	-	-	-	-
d192	Do not use	-	-	-	-	-
d198	Do not use	-	-	-	-	-
d201	Position Control Feed Forward Gain	<div style="display: flex; justify-content: space-between; font-size: small;"> <span>V/f</span> <span>DTV</span> <span>PG V/f</span> <span>PG DTV</span> </div> <div style="display: flex; justify-content: space-between; font-size: small;"> <span>SLV</span> <span>PGV</span> <span>PM SLV</span> <span>PM PGV</span> </div> 0.00: Disable feed-forward 0.01 to 1.50	0.00	Available	-	page 6-38 page 6-49
d202	Position Control Feed Forward Filter	<div style="display: flex; justify-content: space-between; font-size: small;"> <span>V/f</span> <span>DTV</span> <span>PG V/f</span> <span>PG DTV</span> </div> <div style="display: flex; justify-content: space-between; font-size: small;"> <span>SLV</span> <span>PGV</span> <span>PM SLV</span> <span>PM PGV</span> </div> 0.000 to 5.000 s	0.500	Available	s	page 6-38 page 6-49
d203	Position Loop Gain 1	<div style="display: flex; justify-content: space-between; font-size: small;"> <span>V/f</span> <span>DTV</span> <span>PG V/f</span> <span>PG DTV</span> </div> <div style="display: flex; justify-content: space-between; font-size: small;"> <span>SLV</span> <span>PGV</span> <span>PM SLV</span> <span>PM PGV</span> </div> 0.1 to 300.0	1.0	Available	-	page 6-38 page 6-49

Parameter No.	Function name	Monitor or Data Range	Default data	Setting during RUN	Unit	Page
d204	Position Loop Gain 2	<div style="display: flex; justify-content: space-between; border-bottom: 1px solid black; padding-bottom: 2px;"> <span>V/f</span> <span>DTV</span> <span>PG V/f</span> <span>PG DTV</span> </div> <div style="display: flex; justify-content: space-between; border-bottom: 1px solid black; padding-bottom: 2px;"> <span>SLV</span> <span>PGV</span> <span>PM SLV</span> <span>PM PGV</span> </div> 0.1 to 300.0	1.0	Available	-	page 6-38 page 6-49
d205	Position Loop Gain Switch Frequency	<div style="display: flex; justify-content: space-between; border-bottom: 1px solid black; padding-bottom: 2px;"> <span>V/f</span> <span>DTV</span> <span>PG V/f</span> <span>PG DTV</span> </div> <div style="display: flex; justify-content: space-between; border-bottom: 1px solid black; padding-bottom: 2px;"> <span>SLV</span> <span>PGV</span> <span>PM SLV</span> <span>PM PGV</span> </div> 0.0 to 590.0 Hz	0.0	Available	Hz	page 6-38 page 6-49
d206	Electronic Gear Denominator	<div style="display: flex; justify-content: space-between; border-bottom: 1px solid black; padding-bottom: 2px;"> <span>V/f</span> <span>DTV</span> <span>PG V/f</span> <span>PG DTV</span> </div> <div style="display: flex; justify-content: space-between; border-bottom: 1px solid black; padding-bottom: 2px;"> <span>SLV</span> <span>PGV</span> <span>PM SLV</span> <span>PM PGV</span> </div> 1 to 65535	1	-	-	page 6-39 page 6-49
d207	Electronic Gear Numerator	<div style="display: flex; justify-content: space-between; border-bottom: 1px solid black; padding-bottom: 2px;"> <span>V/f</span> <span>DTV</span> <span>PG V/f</span> <span>PG DTV</span> </div> <div style="display: flex; justify-content: space-between; border-bottom: 1px solid black; padding-bottom: 2px;"> <span>SLV</span> <span>PGV</span> <span>PM SLV</span> <span>PM PGV</span> </div> 1 to 65535	1	-	-	page 6-39 page 6-49
d208	Orientation Selection	<div style="display: flex; justify-content: space-between; border-bottom: 1px solid black; padding-bottom: 2px;"> <span>V/f</span> <span>DTV</span> <span>PG V/f</span> <span>PG DTV</span> </div> <div style="display: flex; justify-content: space-between; border-bottom: 1px solid black; padding-bottom: 2px;"> <span>SLV</span> <span>PGV</span> <span>PM SLV</span> <span>PM PGV</span> </div> 0: Nearest direction (Valid for reverse rotation) 1: Command direction (Direction of operation command source)	1	-	-	page 6-49
d209	Homing Operation Selection	<div style="display: flex; justify-content: space-between; border-bottom: 1px solid black; padding-bottom: 2px;"> <span>V/f</span> <span>DTV</span> <span>PG V/f</span> <span>PG DTV</span> </div> <div style="display: flex; justify-content: space-between; border-bottom: 1px solid black; padding-bottom: 2px;"> <span>SLV</span> <span>PGV</span> <span>PM SLV</span> <span>PM PGV</span> </div> Bit 7: Z phase correction 0: Disable 1: Enable Bit 4 to 6: Reserved Bit 3: Detection timing of homing limit switch 0: By rising edge 1: By falling edge Bit 2: OT detected operation selection 0: Return at FOT/ROT detection 1: Stop at OT detection (Cancel homing) Bit 1: Homing Start direction 0: Forward direction 1: Reverse direction Bit 0: Homing shaft direction 0: Forward direction 1: Reverse direction	0	-	-	page 6-49

Parameter No.	Function name	Monitor or Data Range	Default data	Setting during RUN	Unit	Page
d211	Homing Reference Signal Selection	<div style="display: flex; justify-content: space-between; border-bottom: 1px solid black; padding-bottom: 2px;"> <span>V/f</span> <span>DTV</span> <span>PG V/f</span> <span>PG DTV</span> </div> <div style="display: flex; justify-content: space-between; border-bottom: 1px solid black; padding-bottom: 2px;"> <span>SLV</span> <span>PGV</span> <span>PM SLV</span> <span>PM PGV</span> </div> <p>0: Z phase  1: Origin limit input (ORL)  2: Overtravel input in the positive direction (FOT)  3: Overtravel input in the negative direction (ROT)</p>	1	-	-	page 6-44
d212	Reference Signal for Homing Offset	<div style="display: flex; justify-content: space-between; border-bottom: 1px solid black; padding-bottom: 2px;"> <span>V/f</span> <span>DTV</span> <span>PG V/f</span> <span>PG DTV</span> </div> <div style="display: flex; justify-content: space-between; border-bottom: 1px solid black; padding-bottom: 2px;"> <span>SLV</span> <span>PGV</span> <span>PM SLV</span> <span>PM PGV</span> </div> <p>0: Z phase  1: Origin limit input (ORL)  2: Overtravel input in the positive direction (FOT)  3: Overtravel input in the negative direction (ROT)  4: Stopper (Hit and stop)</p>	0	-	-	page 6-44
d213	Homing Frequency/ Orientation Frequency	<div style="display: flex; justify-content: space-between; border-bottom: 1px solid black; padding-bottom: 2px;"> <span>V/f</span> <span>DTV</span> <span>PG V/f</span> <span>PG DTV</span> </div> <div style="display: flex; justify-content: space-between; border-bottom: 1px solid black; padding-bottom: 2px;"> <span>SLV</span> <span>PGV</span> <span>PM SLV</span> <span>PM PGV</span> </div> <p>0.1 to 590.0 Hz</p>	5	Available	Hz	page 6-49
d214	Creep Frequency	<div style="display: flex; justify-content: space-between; border-bottom: 1px solid black; padding-bottom: 2px;"> <span>V/f</span> <span>DTV</span> <span>PG V/f</span> <span>PG DTV</span> </div> <div style="display: flex; justify-content: space-between; border-bottom: 1px solid black; padding-bottom: 2px;"> <span>SLV</span> <span>PGV</span> <span>PM SLV</span> <span>PM PGV</span> </div> <p>0.1 to 590.0 Hz</p>	0.5	Available	Hz	page 6-44
d215	Deceleration Time for Homing/Orientation	<div style="display: flex; justify-content: space-between; border-bottom: 1px solid black; padding-bottom: 2px;"> <span>V/f</span> <span>DTV</span> <span>PG V/f</span> <span>PG DTV</span> </div> <div style="display: flex; justify-content: space-between; border-bottom: 1px solid black; padding-bottom: 2px;"> <span>SLV</span> <span>PGV</span> <span>PM SLV</span> <span>PM PGV</span> </div> <p>0.00 to 6000 s</p>	6.00	Available	s	page 6-49
d220	Position Feedback Store Selection at Power Off	<div style="display: flex; justify-content: space-between; border-bottom: 1px solid black; padding-bottom: 2px;"> <span>V/f</span> <span>DTV</span> <span>PG V/f</span> <span>PG DTV</span> </div> <div style="display: flex; justify-content: space-between; border-bottom: 1px solid black; padding-bottom: 2px;"> <span>SLV</span> <span>PGV</span> <span>PM SLV</span> <span>PM PGV</span> </div> <p>0: Disable  1: Store at low voltage detected</p>	0	Available	-	page 6-61
d221	Current Position Clear Signal Operation Selection	<div style="display: flex; justify-content: space-between; border-bottom: 1px solid black; padding-bottom: 2px;"> <span>V/f</span> <span>DTV</span> <span>PG V/f</span> <span>PG DTV</span> </div> <div style="display: flex; justify-content: space-between; border-bottom: 1px solid black; padding-bottom: 2px;"> <span>SLV</span> <span>PGV</span> <span>PM SLV</span> <span>PM PGV</span> </div> <p>0: Edge  1: Level</p>	0	Available	-	page 6-49
d222	Overtravel Function Selection	<div style="display: flex; justify-content: space-between; border-bottom: 1px solid black; padding-bottom: 2px;"> <span>V/f</span> <span>DTV</span> <span>PG V/f</span> <span>PG DTV</span> </div> <div style="display: flex; justify-content: space-between; border-bottom: 1px solid black; padding-bottom: 2px;"> <span>SLV</span> <span>PGV</span> <span>PM SLV</span> <span>PM PGV</span> </div> <p>0: Invalid/Infinite rotation  1: Valid (Positioning at OT position at over traveling), normal PTP  2: Valid (Immediately stopped at over traveling), normal PTP</p>	0	Available	-	page 6-43



Parameter No.	Function name	Monitor or Data Range	Default data	Setting during RUN	Unit	Page
d223	Detection Level of Excessive Positioning Deviation (MSB)	<div style="display: flex; justify-content: space-between; border-bottom: 1px solid black; padding-bottom: 2px;"> <span>V/f</span> <span>DTV</span> <span>PG V/f</span> <span>PG DTV</span> </div> <div style="display: flex; justify-content: space-between; border-bottom: 1px solid black; padding-bottom: 2px;"> <span>SLV</span> <span>PGV</span> <span>PM SLV</span> <span>PM PGV</span> </div> 0: Disable (MSB: 0, LSB: 0) 1 to 268435455 (MSB: 0 to 4,095, LSB: 0 to 65,535)	0	Available	-	page 6-61
d224	Detection Level of Excessive Positioning Deviation (LSB)	<div style="display: flex; justify-content: space-between; border-bottom: 1px solid black; padding-bottom: 2px;"> <span>V/f</span> <span>DTV</span> <span>PG V/f</span> <span>PG DTV</span> </div> <div style="display: flex; justify-content: space-between; border-bottom: 1px solid black; padding-bottom: 2px;"> <span>SLV</span> <span>PGV</span> <span>PM SLV</span> <span>PM PGV</span> </div> 0: Disable (MSB: 0, LSB: 0) 1 to 268435455 (MSB: 0 to 4,095, LSB: 0 to 65,535)	0	Available	-	page 6-61
d225	Software Overtravel Detection Position in the Positive Direction (MSB)	<div style="display: flex; justify-content: space-between; border-bottom: 1px solid black; padding-bottom: 2px;"> <span>V/f</span> <span>DTV</span> <span>PG V/f</span> <span>PG DTV</span> </div> <div style="display: flex; justify-content: space-between; border-bottom: 1px solid black; padding-bottom: 2px;"> <span>SLV</span> <span>PGV</span> <span>PM SLV</span> <span>PM PGV</span> </div> -268435455 to 268435455 (MSB: -4,096 to 4,095, LSB: 0 to 65,535)	4095	-	-	page 6-43
d226	Software Overtravel Detection Position in the Positive Direction (LSB)	<div style="display: flex; justify-content: space-between; border-bottom: 1px solid black; padding-bottom: 2px;"> <span>V/f</span> <span>DTV</span> <span>PG V/f</span> <span>PG DTV</span> </div> <div style="display: flex; justify-content: space-between; border-bottom: 1px solid black; padding-bottom: 2px;"> <span>SLV</span> <span>PGV</span> <span>PM SLV</span> <span>PM PGV</span> </div> -268435455 to 268435455 (MSB: -4,096 to 4,095, LSB: 0 to 65,535)	65535	-	-	page 6-43
d227	Software Overtravel Detection Position in the Negative Direction (MSB)	<div style="display: flex; justify-content: space-between; border-bottom: 1px solid black; padding-bottom: 2px;"> <span>V/f</span> <span>DTV</span> <span>PG V/f</span> <span>PG DTV</span> </div> <div style="display: flex; justify-content: space-between; border-bottom: 1px solid black; padding-bottom: 2px;"> <span>SLV</span> <span>PGV</span> <span>PM SLV</span> <span>PM PGV</span> </div> -268435455 to 268435455 (MSB: -4,096 to 4,095, LSB: 0 to 65,535)	-4096	-	-	page 6-43
d228	Software Overtravel Detection Position in the Negative Direction (LSB)	<div style="display: flex; justify-content: space-between; border-bottom: 1px solid black; padding-bottom: 2px;"> <span>V/f</span> <span>DTV</span> <span>PG V/f</span> <span>PG DTV</span> </div> <div style="display: flex; justify-content: space-between; border-bottom: 1px solid black; padding-bottom: 2px;"> <span>SLV</span> <span>PGV</span> <span>PM SLV</span> <span>PM PGV</span> </div> -268435455 to 268435455 (MSB: -4,096 to 4,095, LSB: 0 to 65,535)	1	-	-	page 6-43
d237	Positioning Data Type	<div style="display: flex; justify-content: space-between; border-bottom: 1px solid black; padding-bottom: 2px;"> <span>V/f</span> <span>DTV</span> <span>PG V/f</span> <span>PG DTV</span> </div> <div style="display: flex; justify-content: space-between; border-bottom: 1px solid black; padding-bottom: 2px;"> <span>SLV</span> <span>PGV</span> <span>PM SLV</span> <span>PM PGV</span> </div> 0: Absolute position (ABS) 1: Relative position (INC)	0	Available	-	page 6-49
d238	Position Data Determination Time	<div style="display: flex; justify-content: space-between; border-bottom: 1px solid black; padding-bottom: 2px;"> <span>V/f</span> <span>DTV</span> <span>PG V/f</span> <span>PG DTV</span> </div> <div style="display: flex; justify-content: space-between; border-bottom: 1px solid black; padding-bottom: 2px;"> <span>SLV</span> <span>PGV</span> <span>PM SLV</span> <span>PM PGV</span> </div> 0.000 to 0.100 s	0.000	Available	s	page 6-49
d239	Positioning Completed Range	<div style="display: flex; justify-content: space-between; border-bottom: 1px solid black; padding-bottom: 2px;"> <span>V/f</span> <span>DTV</span> <span>PG V/f</span> <span>PG DTV</span> </div> <div style="display: flex; justify-content: space-between; border-bottom: 1px solid black; padding-bottom: 2px;"> <span>SLV</span> <span>PGV</span> <span>PM SLV</span> <span>PM PGV</span> </div> 0 to 9999	1	Available	-	page 6-49 page 6-58

Parameter No.	Function name	Monitor or Data Range	Default data	Setting during RUN	Unit	Page
d240	Preset Position (MSB)	<input type="checkbox"/> V/f <input type="checkbox"/> DTV <input type="checkbox"/> PG V/f <input type="checkbox"/> PG DTV <input type="checkbox"/> SLV <input type="checkbox"/> PGV <input type="checkbox"/> PM SLV <input type="checkbox"/> PM PGV -268435455 to 268435455 (MSB: -4,096 to 4,095, LSB: 0 to 65,535)	0	Available	-	page 6-49
d241	Preset Position (LSB)	<input type="checkbox"/> V/f <input type="checkbox"/> DTV <input type="checkbox"/> PG V/f <input type="checkbox"/> PG DTV <input type="checkbox"/> SLV <input type="checkbox"/> PGV <input type="checkbox"/> PM SLV <input type="checkbox"/> PM PGV -268435455 to 268435455 (MSB: -4,096 to 4,095, LSB: 0 to 65,535)	0	Available	-	page 6-49
d242	Homing Offset (MSB)	<input type="checkbox"/> V/f <input type="checkbox"/> DTV <input type="checkbox"/> PG V/f <input type="checkbox"/> PG DTV <input type="checkbox"/> SLV <input type="checkbox"/> PGV <input type="checkbox"/> PM SLV <input type="checkbox"/> PM PGV -268435455 to 268435455 (MSB: -4,096 to 4,095, LSB: 0 to 65,535)	0	Available	-	page 6-49
d243	Homing Offset (LSB)	<input type="checkbox"/> V/f <input type="checkbox"/> DTV <input type="checkbox"/> PG V/f <input type="checkbox"/> PG DTV <input type="checkbox"/> SLV <input type="checkbox"/> PGV <input type="checkbox"/> PM SLV <input type="checkbox"/> PM PGV -268435455 to 268435455 (MSB: -4,096 to 4,095, LSB: 0 to 65,535)	0	Available	-	page 6-49
d244	Positioning Data 1 (MSB)	<input type="checkbox"/> V/f <input type="checkbox"/> DTV <input type="checkbox"/> PG V/f <input type="checkbox"/> PG DTV <input type="checkbox"/> SLV <input type="checkbox"/> PGV <input type="checkbox"/> PM SLV <input type="checkbox"/> PM PGV -268435455 to 268435455 (MSB: -4,096 to 4,095, LSB: 0 to 65,535)	0	Available	-	page 6-49
d245	Positioning Data 1 (LSB)	<input type="checkbox"/> V/f <input type="checkbox"/> DTV <input type="checkbox"/> PG V/f <input type="checkbox"/> PG DTV <input type="checkbox"/> SLV <input type="checkbox"/> PGV <input type="checkbox"/> PM SLV <input type="checkbox"/> PM PGV -268435455 to 268435455 (MSB: -4,096 to 4,095, LSB: 0 to 65,535)	0	Available	-	page 6-49
d246	Positioning Data 2 (MSB)	<input type="checkbox"/> V/f <input type="checkbox"/> DTV <input type="checkbox"/> PG V/f <input type="checkbox"/> PG DTV <input type="checkbox"/> SLV <input type="checkbox"/> PGV <input type="checkbox"/> PM SLV <input type="checkbox"/> PM PGV -268435455 to 268435455 (MSB: -4,096 to 4,095, LSB: 0 to 65,535)	0	Available	-	page 6-49
d247	Positioning Data 2 (LSB)	<input type="checkbox"/> V/f <input type="checkbox"/> DTV <input type="checkbox"/> PG V/f <input type="checkbox"/> PG DTV <input type="checkbox"/> SLV <input type="checkbox"/> PGV <input type="checkbox"/> PM SLV <input type="checkbox"/> PM PGV -268435455 to 268435455 (MSB: -4,096 to 4,095, LSB: 0 to 65,535)	0	Available	-	page 6-49

Parameter No.	Function name	Monitor or Data Range	Default data	Setting during RUN	Unit	Page
d248	Positioning Data 3 (MSB)	<input type="checkbox"/> V/f <input type="checkbox"/> DTV <input type="checkbox"/> PG V/f <input type="checkbox"/> PG DTV <input type="checkbox"/> SLV <input type="checkbox"/> PGV <input type="checkbox"/> PM SLV <input type="checkbox"/> PM PGV -268435455 to 268435455 (MSB: -4,096 to 4,095, LSB: 0 to 65,535)	0	Available	-	page 6-49
d249	Positioning Data 3 (LSB)	<input type="checkbox"/> V/f <input type="checkbox"/> DTV <input type="checkbox"/> PG V/f <input type="checkbox"/> PG DTV <input type="checkbox"/> SLV <input type="checkbox"/> PGV <input type="checkbox"/> PM SLV <input type="checkbox"/> PM PGV -268435455 to 268435455 (MSB: -4,096 to 4,095, LSB: 0 to 65,535)	0	Available	-	page 6-49
d250	Positioning Data 4 (MSB)	<input type="checkbox"/> V/f <input type="checkbox"/> DTV <input type="checkbox"/> PG V/f <input type="checkbox"/> PG DTV <input type="checkbox"/> SLV <input type="checkbox"/> PGV <input type="checkbox"/> PM SLV <input type="checkbox"/> PM PGV -268435455 to 268435455 (MSB: -4,096 to 4,095, LSB: 0 to 65,535)	0	Available	-	page 6-49
d251	Positioning Data 4 (LSB)	<input type="checkbox"/> V/f <input type="checkbox"/> DTV <input type="checkbox"/> PG V/f <input type="checkbox"/> PG DTV <input type="checkbox"/> SLV <input type="checkbox"/> PGV <input type="checkbox"/> PM SLV <input type="checkbox"/> PM PGV -268435455 to 268435455 (MSB: -4,096 to 4,095, LSB: 0 to 65,535)	0	Available	-	page 6-49
d252	Positioning Data 5 (MSB)	<input type="checkbox"/> V/f <input type="checkbox"/> DTV <input type="checkbox"/> PG V/f <input type="checkbox"/> PG DTV <input type="checkbox"/> SLV <input type="checkbox"/> PGV <input type="checkbox"/> PM SLV <input type="checkbox"/> PM PGV -268435455 to 268435455 (MSB: -4,096 to 4,095, LSB: 0 to 65,535)	0	Available	-	page 6-49
d253	Positioning Data 5 (LSB)	<input type="checkbox"/> V/f <input type="checkbox"/> DTV <input type="checkbox"/> PG V/f <input type="checkbox"/> PG DTV <input type="checkbox"/> SLV <input type="checkbox"/> PGV <input type="checkbox"/> PM SLV <input type="checkbox"/> PM PGV -268435455 to 268435455 (MSB: -4,096 to 4,095, LSB: 0 to 65,535)	0	Available	-	page 6-49
d254	Positioning Data 6 (MSB)	<input type="checkbox"/> V/f <input type="checkbox"/> DTV <input type="checkbox"/> PG V/f <input type="checkbox"/> PG DTV <input type="checkbox"/> SLV <input type="checkbox"/> PGV <input type="checkbox"/> PM SLV <input type="checkbox"/> PM PGV -268435455 to 268435455 (MSB: -4,096 to 4,095, LSB: 0 to 65,535)	0	Available	-	page 6-49
d255	Positioning Data 6 (LSB)	<input type="checkbox"/> V/f <input type="checkbox"/> DTV <input type="checkbox"/> PG V/f <input type="checkbox"/> PG DTV <input type="checkbox"/> SLV <input type="checkbox"/> PGV <input type="checkbox"/> PM SLV <input type="checkbox"/> PM PGV -268435455 to 268435455 (MSB: -4,096 to 4,095, LSB: 0 to 65,535)	0	Available	-	page 6-49

Parameter No.	Function name	Monitor or Data Range	Default data	Setting during RUN	Unit	Page
d256	Positioning Data 7 (MSB)	<div style="display: flex; justify-content: space-between; font-size: small;"> <span>V/f</span> <span>DTV</span> <span>PG V/f</span> <span>PG DTV</span> </div> <div style="display: flex; justify-content: space-between; font-size: small;"> <span>SLV</span> <span>PGV</span> <span>PM SLV</span> <span>PM PGV</span> </div> -268435455 to 268435455 (MSB: -4,096 to 4,095, LSB: 0 to 65,535)	0	Available	-	page 6-49
d257	Positioning Data 7 (LSB)	<div style="display: flex; justify-content: space-between; font-size: small;"> <span>V/f</span> <span>DTV</span> <span>PG V/f</span> <span>PG DTV</span> </div> <div style="display: flex; justify-content: space-between; font-size: small;"> <span>SLV</span> <span>PGV</span> <span>PM SLV</span> <span>PM PGV</span> </div> -268435455 to 268435455 (MSB: -4,096 to 4,095, LSB: 0 to 65,535)	0	Available	-	page 6-49
d258	Positioning Data 8 (MSB)	<div style="display: flex; justify-content: space-between; font-size: small;"> <span>V/f</span> <span>DTV</span> <span>PG V/f</span> <span>PG DTV</span> </div> <div style="display: flex; justify-content: space-between; font-size: small;"> <span>SLV</span> <span>PGV</span> <span>PM SLV</span> <span>PM PGV</span> </div> -268435455 to 268435455 (MSB: -4,096 to 4,095, LSB: 0 to 65,535)	0	Available	-	page 6-49
d259	Positioning Data 8 (LSB)	<div style="display: flex; justify-content: space-between; font-size: small;"> <span>V/f</span> <span>DTV</span> <span>PG V/f</span> <span>PG DTV</span> </div> <div style="display: flex; justify-content: space-between; font-size: small;"> <span>SLV</span> <span>PGV</span> <span>PM SLV</span> <span>PM PGV</span> </div> -268435455 to 268435455 (MSB: -4,096 to 4,095, LSB: 0 to 65,535)	0	Available	-	page 6-49
d277	Positioning Data Setting Selection via communication	<div style="display: flex; justify-content: space-between; font-size: small;"> <span>V/f</span> <span>DTV</span> <span>PG V/f</span> <span>PG DTV</span> </div> <div style="display: flex; justify-content: space-between; font-size: small;"> <span>SLV</span> <span>PGV</span> <span>PM SLV</span> <span>PM PGV</span> </div> 0: Disable Communications Positioning Data (S20, S21) 1: Enable Communications Positioning Data (S20, S21)	0	Available	-	page 6-49
d278	Restarting Positioning Range Setting	<div style="display: flex; justify-content: space-between; font-size: small;"> <span>V/f</span> <span>DTV</span> <span>PG V/f</span> <span>PG DTV</span> </div> <div style="display: flex; justify-content: space-between; font-size: small;"> <span>SLV</span> <span>PGV</span> <span>PM SLV</span> <span>PM PGV</span> </div> 0: Disable 1~9999	0	Available	-	page 6-58
d280	Over Travel Forced Stop Operation Selection	<div style="display: flex; justify-content: space-between; font-size: small;"> <span>V/f</span> <span>DTV</span> <span>PG V/f</span> <span>PG DTV</span> </div> <div style="display: flex; justify-content: space-between; font-size: small;"> <span>SLV</span> <span>PGV</span> <span>PM SLV</span> <span>PM PGV</span> </div> 0: Servo lock after deceleration stop 1: Er6 fault occurs after deceleration stop	0	Available	-	page 6-43
d296	Current Reference Position Monitor (MSB)	<div style="display: flex; justify-content: space-between; font-size: small;"> <span>V/f</span> <span>DTV</span> <span>PG V/f</span> <span>PG DTV</span> </div> <div style="display: flex; justify-content: space-between; font-size: small;"> <span>SLV</span> <span>PGV</span> <span>PM SLV</span> <span>PM PGV</span> </div> -268435455 to 268435455 (MSB: -4096 to 4095, LSB: 0 to 65535)	0	-	-	page 6-57

Parameter No.	Function name	Monitor or Data Range	Default data	Setting during RUN	Unit	Page
d297	Current Reference Position Monitor (LSB)	<div style="display: flex; justify-content: space-between; border-bottom: 1px solid black; padding-bottom: 2px;"> <span>V/f</span> <span>DTV</span> <span>PG V/f</span> <span>PG DTV</span> </div> <div style="display: flex; justify-content: space-between; border-bottom: 1px solid black; padding-bottom: 2px;"> <span>SLV</span> <span>PGV</span> <span>PM SLV</span> <span>PM PGV</span> </div> -268435455 to 268435455 (MSB: -4096 to 4095, LSB: 0 to 65535)	0	-	-	page 6-57
d298	Current Feedback Position Monitor (MSB)	<div style="display: flex; justify-content: space-between; border-bottom: 1px solid black; padding-bottom: 2px;"> <span>V/f</span> <span>DTV</span> <span>PG V/f</span> <span>PG DTV</span> </div> <div style="display: flex; justify-content: space-between; border-bottom: 1px solid black; padding-bottom: 2px;"> <span>SLV</span> <span>PGV</span> <span>PM SLV</span> <span>PM PGV</span> </div> -268435455 to 268435455 (MSB: -4096 to 4095, LSB: 0 to 65535)	0	-	-	page 6-57
d299	Current Feedback Position Monitor (LSB)	<div style="display: flex; justify-content: space-between; border-bottom: 1px solid black; padding-bottom: 2px;"> <span>V/f</span> <span>DTV</span> <span>PG V/f</span> <span>PG DTV</span> </div> <div style="display: flex; justify-content: space-between; border-bottom: 1px solid black; padding-bottom: 2px;"> <span>SLV</span> <span>PGV</span> <span>PM SLV</span> <span>PM PGV</span> </div> -268435455 to 268435455 (MSB: -4096 to 4095, LSB: 0 to 65535)	0	-	-	page 6-57

#### 4-2-11 Parameter y (RS-485 Communication Settings)

Parameter No.	Function name	Monitor or Data Range	Default data	Setting during RUN	Unit	Page
y11	RS-485 Communication Station No. Selection	<div style="display: flex; justify-content: space-between; border-bottom: 1px solid black; padding-bottom: 2px;"> <span>V/f</span> <span>DTV</span> <span>PG V/f</span> <span>PG DTV</span> </div> <div style="display: flex; justify-content: space-between; border-bottom: 1px solid black; padding-bottom: 2px;"> <span>SLV</span> <span>PGV</span> <span>PM SLV</span> <span>PM PGV</span> </div> 1 to 255	1	-	-	page 8-5
y12	Operation Selection on Communication Error	<div style="display: flex; justify-content: space-between; border-bottom: 1px solid black; padding-bottom: 2px;"> <span>V/f</span> <span>DTV</span> <span>PG V/f</span> <span>PG DTV</span> </div> <div style="display: flex; justify-content: space-between; border-bottom: 1px solid black; padding-bottom: 2px;"> <span>SLV</span> <span>PGV</span> <span>PM SLV</span> <span>PM PGV</span> </div> 0: Immediately trip with alarm ErP 1: Trip with alarm ErP after running for the period specified by timer y03 2: Retry during the period specified by timer y03. If the retry fails trip with alarm ErP. If it succeeds continue to run. 3: Continue to run 11: Trip with alarm ErP after deceleration stop 13: Free run stop 14: Deceleration stop	0	Available	-	page 8-5
y13	RS-485 Error Detection Timer	<div style="display: flex; justify-content: space-between; border-bottom: 1px solid black; padding-bottom: 2px;"> <span>V/f</span> <span>DTV</span> <span>PG V/f</span> <span>PG DTV</span> </div> <div style="display: flex; justify-content: space-between; border-bottom: 1px solid black; padding-bottom: 2px;"> <span>SLV</span> <span>PGV</span> <span>PM SLV</span> <span>PM PGV</span> </div> 0.0 to 60.0 s	2	Available	s	page 8-5

Parameter No.	Function name	Monitor or Data Range	Default data	Setting during RUN	Unit	Page
y14	RS-485 Communication Baud Rate	<div style="display: flex; justify-content: space-between; border-bottom: 1px solid black; padding-bottom: 2px;"> <span>V/f</span> <span>DTV</span> <span>PG V/f</span> <span>PG DTV</span> </div> <div style="display: flex; justify-content: space-between; border-bottom: 1px solid black; padding-bottom: 2px;"> <span>SLV</span> <span>PGV</span> <span>PM SLV</span> <span>PM PGV</span> </div> 0: 2400 bps 1: 4800 bps 2: 9600 bps 3: 19200 bps 4: 38400 bps 5: 57600 bps 6: 76800 bps 7: 115200 bps	2	Available	-	page 8-5
y16	RS-485 Communication Parity Bit Selection	<div style="display: flex; justify-content: space-between; border-bottom: 1px solid black; padding-bottom: 2px;"> <span>V/f</span> <span>DTV</span> <span>PG V/f</span> <span>PG DTV</span> </div> <div style="display: flex; justify-content: space-between; border-bottom: 1px solid black; padding-bottom: 2px;"> <span>SLV</span> <span>PGV</span> <span>PM SLV</span> <span>PM PGV</span> </div> 0: None (Stop bit: 2 bits) 1: Even number parity (Stop bit: 1 bits) 2: Odd number parity (Stop bit: 1 bits) 3: None (Stop bit: 1 bits)	3	Available	-	page 8-5
y18	RS-485 Communication Timeout Time	<div style="display: flex; justify-content: space-between; border-bottom: 1px solid black; padding-bottom: 2px;"> <span>V/f</span> <span>DTV</span> <span>PG V/f</span> <span>PG DTV</span> </div> <div style="display: flex; justify-content: space-between; border-bottom: 1px solid black; padding-bottom: 2px;"> <span>SLV</span> <span>PGV</span> <span>PM SLV</span> <span>PM PGV</span> </div> 0: Not check of the time-out (OFF) 1 to 60 s	0	Available	s	page 8-5
y19	RS-485 Communication Response Interval Time	<div style="display: flex; justify-content: space-between; border-bottom: 1px solid black; padding-bottom: 2px;"> <span>V/f</span> <span>DTV</span> <span>PG V/f</span> <span>PG DTV</span> </div> <div style="display: flex; justify-content: space-between; border-bottom: 1px solid black; padding-bottom: 2px;"> <span>SLV</span> <span>PGV</span> <span>PM SLV</span> <span>PM PGV</span> </div> 0.00 to 1.00 s	0.01	Available	s	page 8-5
y95	Data Clear Processing for Communications Error	<div style="display: flex; justify-content: space-between; border-bottom: 1px solid black; padding-bottom: 2px;"> <span>V/f</span> <span>DTV</span> <span>PG V/f</span> <span>PG DTV</span> </div> <div style="display: flex; justify-content: space-between; border-bottom: 1px solid black; padding-bottom: 2px;"> <span>SLV</span> <span>PGV</span> <span>PM SLV</span> <span>PM PGV</span> </div> 0: Do not clear the data of function codes S when a communications error occurs. (compatible with the conventional inverters) 1: Clear the data of function codes S001, S005, and S019 when a communications error occurs 2: Clear the run command assigned bit of function code S06 when a communications error occurs 3: Clear both data 1 and 2 above	0	Available	-	page 9-2

Parameter No.	Function name	Monitor or Data Range	Default data	Setting during RUN	Unit	Page
y97	Communication Data Storage Selection	<div style="display: flex; justify-content: space-between; border: 1px solid black; padding: 2px;"> <span>V/f</span> <span>DTV</span> <span>PG V/f</span> <span>PG DTV</span> </div> <div style="display: flex; justify-content: space-between; border: 1px solid black; padding: 2px;"> <span>SLV</span> <span>PGV</span> <span>PM SLV</span> <span>PM PGV</span> </div> <p>0: Store into nonvolatile memory (Rewritable times are limited)</p> <p>1: Write into temporary memory (Rewritable times are unlimited)</p> <p>2: Save all data from temporary memory to nonvolatile memory (After all data is saved, return to Data 1)</p>	1	Available	-	page 8-5
y99	Support Tool Link Function Selection	<div style="display: flex; justify-content: space-between; border: 1px solid black; padding: 2px;"> <span>V/f</span> <span>DTV</span> <span>PG V/f</span> <span>PG DTV</span> </div> <div style="display: flex; justify-content: space-between; border: 1px solid black; padding: 2px;"> <span>SLV</span> <span>PGV</span> <span>PM SLV</span> <span>PM PGV</span> </div> <p>0: Numerical setting and terminal command (including operation command ) by related parameter settings</p> <p>1: Numerical setting uses communications command (support tools)</p> <p>2: Terminal setting uses communications command (support tools)</p> <p>3: Both numerical setting and terminal command use communications command (support tools)</p> <p>Numerical setting means Frequency reference, torque command, or torque bias command.</p>	0	Available	-	-

### 4-2-12 Parameter S (Via RS-485)

These parameters are exclusively for reading and writing via the RS-485 interface. These parameters are not displayed on the Digital Operator. To check these parameters, use Sysmac Studio.

Parameter No.	Function name	Monitor or Data Range	Default data	Setting during RUN	Unit	Page
S01	Frequency Reference	<div style="display: flex; justify-content: space-between; border: 1px solid black; padding: 2px;"> <span>V/f</span> <span>DTV</span> <span>PG V/f</span> <span>PG DTV</span> </div> <div style="display: flex; justify-content: space-between; border: 1px solid black; padding: 2px;"> <span>SLV</span> <span>PGV</span> <span>PM SLV</span> <span>PM PGV</span> </div> <p>-32,768 to 32,767 +20,000 or -20,000 = Maximum output frequency</p>	0	Available	-	page 5-27

## 4 Parameter List

Parameter No.	Function name	Monitor or Data Range	Default data	Setting during RUN	Unit	Page
S02	Torque Reference	<input type="checkbox"/> V/f <input type="checkbox"/> DTV <input type="checkbox"/> PG V/f <input type="checkbox"/> PG DTV <input type="checkbox"/> SLV <input type="checkbox"/> PGV <input type="checkbox"/> PM SLV <input type="checkbox"/> PM PGV -327.68 to 327.67 %	0	Available	%	page 6-31
S03	Torque Current Command	<input type="checkbox"/> V/f <input type="checkbox"/> DTV <input type="checkbox"/> PG V/f <input type="checkbox"/> PG DTV <input type="checkbox"/> SLV <input type="checkbox"/> PGV <input type="checkbox"/> PM SLV <input type="checkbox"/> PM PGV -327.68 to 327.67 %	0	Available	%	page 6-31
S05	Frequency Reference	<input type="checkbox"/> V/f <input type="checkbox"/> DTV <input type="checkbox"/> PG V/f <input type="checkbox"/> PG DTV <input type="checkbox"/> SLV <input type="checkbox"/> PGV <input type="checkbox"/> PM SLV <input type="checkbox"/> PM PGV 0.00 to 655.35 Hz	0	Available	Hz	page 5-27
S06	Input Terminal Monitor	<input type="checkbox"/> V/f <input type="checkbox"/> DTV <input type="checkbox"/> PG V/f <input type="checkbox"/> PG DTV <input type="checkbox"/> SLV <input type="checkbox"/> PGV <input type="checkbox"/> PM SLV <input type="checkbox"/> PM PGV Bit15: RST Bit14: DI7 Bit13: DI6 Bit12: --- Bit11: --- Bit10: --- Bit9: --- Bit8: --- Bit7: --- Bit6: DI5 Bit5: DI4 Bit4: DI3 Bit3: DI2 Bit2: DI1 Bit1: REV Bit0: FWD	0	Available	-	page 5-25 page 5-49 page 7-26
S07	Communication Data Terminal [DO]	<input type="checkbox"/> V/f <input type="checkbox"/> DTV <input type="checkbox"/> PG V/f <input type="checkbox"/> PG DTV <input type="checkbox"/> SLV <input type="checkbox"/> PGV <input type="checkbox"/> PM SLV <input type="checkbox"/> PM PGV Bit15: --- Bit14: --- Bit13: --- Bit12: --- Bit11: --- Bit10: --- Bit9: --- Bit8: RO Bit7: --- Bit6: --- Bit5: --- Bit4: --- Bit3: --- Bit2: --- Bit1: DO2 Bit0: DO1	0	Available	-	page 7-155



Parameter No.	Function name	Monitor or Data Range	Default data	Setting during RUN	Unit	Page
S12	Communication Data Terminal [AO]	<div style="display: flex; justify-content: space-between;"> <span>V/f</span> <span>DTV</span> <span>PG V/f</span> <span>PG DTV</span> </div> <div style="display: flex; justify-content: space-between;"> <span>SLV</span> <span>PGV</span> <span>PM SLV</span> <span>PM PGV</span> </div> <p>-32,768 to 32,767</p>	0	Available	-	page 7-155
S13	PID Control PID Command via Communication	<div style="display: flex; justify-content: space-between;"> <span>V/f</span> <span>DTV</span> <span>PG V/f</span> <span>PG DTV</span> </div> <div style="display: flex; justify-content: space-between;"> <span>SLV</span> <span>PGV</span> <span>PM SLV</span> <span>PM PGV</span> </div> <p>-32,768 to 32,767 -20,000 = -100%, 20,000 = 100%</p>	0	Available	-	page 7-123
S14	Alarm Reset Command	<div style="display: flex; justify-content: space-between;"> <span>V/f</span> <span>DTV</span> <span>PG V/f</span> <span>PG DTV</span> </div> <div style="display: flex; justify-content: space-between;"> <span>SLV</span> <span>PGV</span> <span>PM SLV</span> <span>PM PGV</span> </div> <p>0: Disable 1: Alarm reset</p>	0	Available	-	page 5-49
S15	Torque Bias Value via Communication	<div style="display: flex; justify-content: space-between;"> <span>V/f</span> <span>DTV</span> <span>PG V/f</span> <span>PG DTV</span> </div> <div style="display: flex; justify-content: space-between;"> <span>SLV</span> <span>PGV</span> <span>PM SLV</span> <span>PM PGV</span> </div> <p>-327.68 to 327.67</p>	0	Available	%	page 6-33
S19	Speed Command via Communication	<div style="display: flex; justify-content: space-between;"> <span>V/f</span> <span>DTV</span> <span>PG V/f</span> <span>PG DTV</span> </div> <div style="display: flex; justify-content: space-between;"> <span>SLV</span> <span>PGV</span> <span>PM SLV</span> <span>PM PGV</span> </div> <p>-32768 to 32767</p>	0	Available	r/min	page 5-27
S20	Positioning Data via Communication (MSB)	<div style="display: flex; justify-content: space-between;"> <span>V/f</span> <span>DTV</span> <span>PG V/f</span> <span>PG DTV</span> </div> <div style="display: flex; justify-content: space-between;"> <span>SLV</span> <span>PGV</span> <span>PM SLV</span> <span>PM PGV</span> </div> <p>-268435455 to 268435455 (MSB: -4096 to 4095)</p>	0	Available	-	page 6-41
S21	Positioning Data via Communication (LSB)	<div style="display: flex; justify-content: space-between;"> <span>V/f</span> <span>DTV</span> <span>PG V/f</span> <span>PG DTV</span> </div> <div style="display: flex; justify-content: space-between;"> <span>SLV</span> <span>PGV</span> <span>PM SLV</span> <span>PM PGV</span> </div> <p>(LSB: 0 to 65535)</p>	0	Available	-	page 6-41
S22	Torque Reference via Communication	<div style="display: flex; justify-content: space-between;"> <span>V/f</span> <span>DTV</span> <span>PG V/f</span> <span>PG DTV</span> </div> <div style="display: flex; justify-content: space-between;"> <span>SLV</span> <span>PGV</span> <span>PM SLV</span> <span>PM PGV</span> </div> <p>-327 to 327 %</p>	0	Available	%	page 6-31
S23	Torque Current Command via Communication	<div style="display: flex; justify-content: space-between;"> <span>V/f</span> <span>DTV</span> <span>PG V/f</span> <span>PG DTV</span> </div> <div style="display: flex; justify-content: space-between;"> <span>SLV</span> <span>PGV</span> <span>PM SLV</span> <span>PM PGV</span> </div> <p>-327 to 327 %</p>	0	Available	%	page 6-31
S24	Torque Bias Value	<div style="display: flex; justify-content: space-between;"> <span>V/f</span> <span>DTV</span> <span>PG V/f</span> <span>PG DTV</span> </div> <div style="display: flex; justify-content: space-between;"> <span>SLV</span> <span>PGV</span> <span>PM SLV</span> <span>PM PGV</span> </div> <p>-327 to 327 %</p>	0	Available	%	page 6-33
S30	PID Control Feedback Value via Communication	<div style="display: flex; justify-content: space-between;"> <span>V/f</span> <span>DTV</span> <span>PG V/f</span> <span>PG DTV</span> </div> <div style="display: flex; justify-content: space-between;"> <span>SLV</span> <span>PGV</span> <span>PM SLV</span> <span>PM PGV</span> </div> <p>-32,768 to 32,767 -20,000 = -100%, 20,000 = 100%</p>	0	Available	-	page 7-123



# 5

## Basic Settings

This section describes the basic functions such as the RUN command.

<b>5-1</b>	<b>Display and Initialization .....</b>	<b>5-3</b>
5-1-1	Display Selection .....	5-3
5-1-2	Data Initialization .....	5-4
5-1-3	User Preference Dataset (Registration/Protection) .....	5-8
<b>5-2</b>	<b>Setting V/f Control.....</b>	<b>5-10</b>
5-2-1	Motor Control Method (V/f Characteristics) .....	5-10
5-2-2	Load Mode Selection .....	5-12
5-2-3	Slip Compensation .....	5-16
<b>5-3</b>	<b>Motor Parameter Settings .....</b>	<b>5-19</b>
5-3-1	Induction Motor Basic Settings .....	5-19
5-3-2	Base Frequency and Maximum Frequency of Motor .....	5-19
5-3-3	Motor Electronic Thermal Function .....	5-20
<b>5-4</b>	<b>RUN command .....</b>	<b>5-25</b>
5-4-1	RUN Command Selection .....	5-25
<b>5-5</b>	<b>Frequency Reference.....</b>	<b>5-27</b>
5-5-1	Frequency Reference Selection .....	5-27
5-5-2	Frequency Limit .....	5-32
5-5-3	Pattern Operation / Timed Operation Function.....	5-33
<b>5-6</b>	<b>Acceleration/deceleration time .....</b>	<b>5-39</b>
5-6-1	Acceleration/Deceleration Time Setting .....	5-39
5-6-2	Acceleration/Deceleration Pattern .....	5-40
5-6-3	Acceleration/Deceleration Stop Function .....	5-42
5-6-4	2-step Acceleration/Deceleration Function.....	5-43
<b>5-7</b>	<b>Stop Operation .....</b>	<b>5-47</b>
5-7-1	Stop Selection .....	5-47
<b>5-8</b>	<b>Reset .....</b>	<b>5-49</b>
5-8-1	Reset Function .....	5-49
<b>5-9</b>	<b>Multi-function Input.....</b>	<b>5-51</b>
5-9-1	Input Terminal Functions .....	5-51
<b>5-10</b>	<b>Multi-function output .....</b>	<b>5-67</b>
5-10-1	Output Terminal Functions .....	5-67
<b>5-11</b>	<b>Torque Boost Function .....</b>	<b>5-73</b>
5-11-1	Torque Boost .....	5-73
<b>5-12</b>	<b>Regenerative Braking Function .....</b>	<b>5-75</b>

5-12-1 Regenerative Braking Function ..... 5-75  
5-12-2 Braking Resistor Electronic Thermal Function ..... 5-75

# 5-1 Display and Initialization





## 5-1-1 Display Selection

- The menus displayed in the Program mode can be selected. For an explanation on the menus, refer to 3-1-2 *Key Operation Method* on page 3-3 (Program mode).
- To display all parameters, set “2: Display all parameters.”

Parameter No.	Function name	Data	Default data	Unit
E52	Operator Display Selection	0 to 2 0: Display favorite parameters and all parameters 1: Display change parameters 2: Display all parameters	2	-

Select the menu to display on the Digital Operator at E52. The following table shows the seven menus.

(OK: To be displayed)

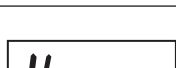
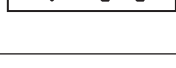
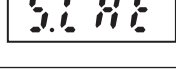
Menu No.	LED monitor display	Display item	E52=0	E52=1	E52=3
0		User parameters	OK		OK
1		All parameters	OK		OK
2		Changed parameters*1		OK	OK
3		Operation status (Refer to 7-1-1 <i>Operation Monitor</i> on page 7-3.)			OK
4		[DI], [AI], [DO], [AO] terminal status (Refer to 7-1-2 <i>I/O check</i> on page 7-11.)			OK
5		Maintenance status (Refer to 7-1-3 <i>Maintenance Information</i> on page 7-13.)			OK
6		Alarm information (Refer to 7-1-4 <i>Alarm information</i> on page 7-18.)			OK



\*1. Only parameters that are different from their factory default values are displayed. When no parameters have been changed, “F\_\_\_” is displayed. Also, Data Initialization (03), Auto Tuning Function Selection (P04/A18) and User Preference Dataset Registration (H193) are not displayed in changed parameters.

\*2. To register to favorite parameters, hold the  key down during display of a parameter. To indicate that a parameter has been registered as a favorite parameter, the decimal point LED of the uppermost digit lights. If the same operation is performed one more time, the parameter is removed from user preferences, and the decimal LED of the uppermost digit turns OFF.

## 5-1-2 Data Initialization

- The parameter initialization function restores changed parameters to the factory default settings.
- It can also clear the fault monitor data.
- When the inverter is newly set after restoring parameters to the factory default settings, execute parameter initialization with “1: Initialize all parameters” set to Data Initialization (H03).
- Note that previous settings cannot be reverted to once the  key is pressed with a value other than “0” is selected at Data Initialization (H03) to execute parameter initialization. After initialization ends, H03 returns to 0.

Parameter No.	Function name	Data	Default data	Unit
H03	Data Initialization	0 to 8 0: Disable 1: Initialize all parameters 2: Initialize motor 1 parameters 3: Initialize motor 2 parameters 4: Restore user defined data 5: Initialize all parameters (except I/O and communications) 6: Reserved 7: Clear alarm history 8: Clear selection of favorite function code	0	-

- Initialization cannot be executed if changes to the parameter used for initialization (H03) is prohibited by the setting of Operator Protection Function Selection (F00). To execute initialization, first disable prohibition of changing the parameter set value in Operator Protection Function Selection (F00). For details on Operator Protection Function Selection, refer to *7-7-1 Soft Lock Function (SFT)* on page 7-74.
- The parameter used for initialization (H03) is not displayed when “1: Display change parameters” is set to Operator Display Selection (E52). For details on Operator (Menu display mode), refer to *5-1-1 Display Selection* on page 5-3.
- During operation, initialization is not possible. Perform initialization after stopping inverter operation. Also, do not enter a RUN command as the inverter might operate unintentionally during initialization.
- Press the  key +  /  key” simultaneously to change the parameter H03 value.

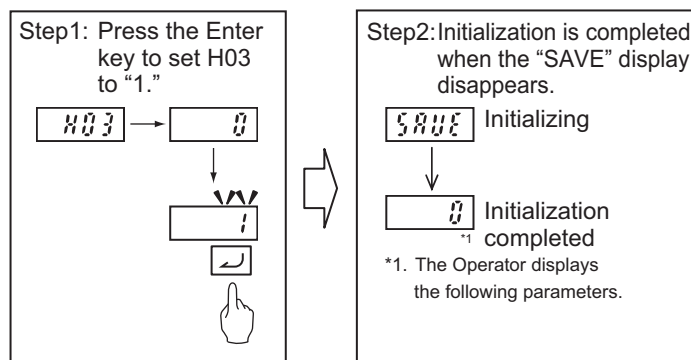

## Initialize all parameters (H03 = 1)

- When “1: Initialize all parameters” is set to Data Initialization (H03), all parameters excluding the following are set to their default data (values at the time of shipment from the factory).

Main Circuit Capacitor Service Life Coefficient (Measurement Value) (H42)

Main Circuit Capacitor Service Life Coefficient (Initial Value) (H47)

Service Life of Main Circuit Capacitor Remaining Time (H77)

Cumulative Run Time of Cooling Fan (H43)

Cumulative Run Time of Capacitors on Printed Circuit Boards (H48)

1st Startup Count for Motor (H44)

2nd Startup Counter for Motor (A52)

1st Cumulative Motor Run Time (H94)

2nd Cumulative Motor Run Time (A51)

User Preference Dataset Protection Function Selection (H194)

Monitor Exclusive Parameters (M, W Parameters)

- Parameters are initialized even if they are protected by a password, and both passwords 1 and 2 are canceled. (Refer to 7-7-5 *Password Function* on page 7-77.)
- User preference dataset saved by User Preference Dataset Registration (H193) are not initialized. (Refer to 5-1-3 *User Preference Dataset (Registration/Protection)* on page 5-8.)

## Initialize Motor 1 Parameters (H03 = 2)

- When “2: Initialize motor 1 parameters” is set to Data Initialization (H03), the following parameters are set to their default data (values at the time of shipment from the factory).

1st Manual Torque Boost Voltage (F09)

1st Motor Electronic Thermal Level (F11)

1st Motor Pole Number (P01)

1st Motor Rated Current (P03)

1st Motor Armature Resistance (P06)

1st Motor Parameter %R1 (P07)

1st Motor Parameter %X (P08)

1st Slip Compensation Gain for Braking (P11)

1st Rated Slip Frequency (P12)

1st Iron Loss Factor 1 (P13)

1st Magnetic Saturation Factor 1 (P16)

1st Magnetic Saturation Factor 2 (P17)

1st Magnetic Saturation Factor 3 (P18)

1st Magnetic Saturation Factor 4 (P19)

1st Magnetic Saturation Factor 5 (P20)

1st PM Motor Starting Method (P30)

1st Motor Torque Current under Vector Control (P55)

1st Induced Voltage Factor under Vector Control (P56)

1st PM Motor Armature Resistance (P60)

1st PM Motor d-axis Inductance (P61)

1st PM Motor q-axis Inductance (P62)

1st PM Motor Induced Voltage Ke (P63)  
1st PM Motor Iron Loss (P64)  
1st PM Motor Reference Current for Magnetic Pole Detection (P87)  
1st PM Motor Overcurrent Protection Level (P90)  
Auto Search Delay Time 2 for Starting Mode (H46)  
Magnetic Flux Level during Deceleration (d90)

### Initialize Motor 2 Parameters (H03 = 3)

---

- When “3: Initialize motor 2 parameters” is set to Data Initialization (H03), the following parameters are set to their default data (values at the time of shipment from the factory).

2nd Manual Torque Boost Voltage (A05)  
2nd Motor Electronic Thermal Level (A07)  
2nd Motor Pole Number (A15)  
2nd Motor Rated Current (A17)  
2nd Motor Armature Resistance (A20)  
2nd Motor Motor Constant %R1 (A21)  
2nd Motor Motor Constant %X (A22)  
2nd Slip Compensation Gain for Braking (A25)  
2nd Rated Slip Frequency (A26)  
2nd Iron Loss Factor 1 (A27)  
2nd Magnetic Saturation Factor 1 (A30)  
2nd Magnetic Saturation Factor 2 (A31)  
2nd Magnetic Saturation Factor 3 (A32)  
2nd Magnetic Saturation Factor 4 (A33)  
2nd Magnetic Saturation Factor 5 (A34)  
Torque Current for 2nd Vector Control (A55)  
Induced Voltage Factor for 2nd Vector Control (A56)

### Restore User Defined Data (H03 = 4)

---

- When “4: Restore user defined data” is set to Data Initialization (H03), parameters are initialized using the user preference dataset saved at User Preference Dataset Registration (H193). When there are no user preference dataset, parameters are initialized using factory defaults. (Same operation as when Data Initialization (H03) is set to 1).
- User preference dataset saved by User Preference Dataset Registration (H193) are not initialized. (Refer to *5-1-3 User Preference Dataset (Registration/Protection)* on page 5-8.)
- The following parameters are not initialized.

Main Circuit Capacitor Service Life Coefficient (Measurement Value) (H42)  
Main Circuit Capacitor Service Life Coefficient (Initial Value) (H47)  
Service Life of Main Circuit Capacitor Remaining Time (H77)  
Cumulative Run Time of Cooling Fan (H43)  
Cumulative Run Time of Capacitors on Printed Circuit Boards (H48)  
1st Startup Count for Motor (H44)  
2nd Startup Counter for Motor (A52)



1st Cumulative Motor Run Time (H94)  
 2nd Cumulative Motor Run Time (A51)  
 User Preference Dataset Protection Function Selection (H194)  
 Monitor Exclusive Parameters (M, W Parameters)

## Initialize All Parameters (Except I/O and Communications) (H03 = 5)

- When “5: Initialize all parameters (except I/O and communications)” is set to Data Initialization (H03), the following parameters excluding I/O and communications are initialized to their factory defaults.

Input Terminal [DI1] Function Selection to Input Terminal [DI7] Function Selection (E01~E05, E98, E99)  
 Output Terminal [DO1] Function Selection, Output Terminal [DO2] Function Selection (E20, E21)  
 Output Terminal [ROA, ROB] Function Selection (E27)  
 RS-485 Communication Station No. Selection (y11)  
 Operation Selection on Communication Error (y12)  
 RS-485 Error Detection Timer (y13)  
 RS-485 Communication Baud Rate (y14)  
 RS-485 Communication Parity Bit Selection (y16)  
 RS-485 Communication Timeout Time (y18)  
 RS-485 Communication Response Interval Time (y19)  
 Data Clear Processing for Communications Error (y95)

Also, the following parameters are not initialized.

Main Circuit Capacitor Service Life Coefficient (Measurement Value) (H42)  
 Main Circuit Capacitor Service Life Coefficient (Initial Value) (H47)  
 Service Life of Main Circuit Capacitor Remaining Time (H77)  
 Cumulative Run Time of Cooling Fan (H43)  
 Cumulative Run Time of Capacitors on Printed Circuit Boards (H48)  
 1st Startup Count for Motor (H44)  
 2nd Startup Counter for Motor (A52)  
 1st Cumulative Motor Run Time (H94)  
 2nd Cumulative Motor Run Time (A51)  
 User Preference Dataset Protection Function Selection (H194)  
 Monitor Exclusive Parameters (M, W Parameters)

## Clear Alarm History (H03 = 7)

- When “7: Clear alarm history” is set to Data Initialization (H03), the alarm history and data at the time of the alarm, multiple alarm information, light alarm history, and number of occurrences are cleared to set to an alarm non-occurring state.
- The alarm information of parameters (refer to *7-1-4 Alarm information* on page 7-18) is initialized.

## Clear Selection of Favorite Function Code (H03 = 8)

- When “8: Clear selection of favorite function code” is set to Data Initialization (H03), the registered state of favorite parameters is cleared (canceled). The values of parameters registered as favorite parameters are not initialized. For details on registering favorite parameters, refer to 7-7-6 *User Parameter Setting Function* on page 7-80.
- To register to favorite parameters, hold the  key down during display of a parameter. To indicate that a parameter has been registered as a favorite parameter, the decimal point LED of the uppermost digit lights. If the same operation is performed one more time, the parameter is removed from user preferences, and the decimal LED of the uppermost digit turns OFF.

### 5-1-3 User Preference Dataset (Registration/Protection)

Set User Preference Dataset Registration/Protection by the following parameters. When “4: Restore user defined data” is set to Data Initialization (H03), parameters are initialized using the saved user preference datasets.

Parameter No.	Function name	Data	Default data	Unit
H193	User Preference Dataset Registration	0: Disable 1: Store	0	-
H194	User Preference Dataset Protection Function Selection	0: Unprotected 1: Protected	0	-
Related function		Data Initialization (H03)		

- The set values of parameters that have been changed from the factory defaults can be saved (registered) as user preference dataset. For parameters also that have not been changed from the factory defaults, factory defaults can be saved (registered) as user preference dataset. Note, however, that the following parameters are not targeted for saving as user preference datasets.

Main Circuit Capacitor Service Life Coefficient (Measurement Value) (H42)

Main Circuit Capacitor Service Life Coefficient (Initial Value) (H47)

Service Life of Main Circuit Capacitor Remaining Time (H77)

Cumulative Run Time of Cooling Fan (H43)

Cumulative Run Time of Capacitors on Printed Circuit Boards (H48)

1st Startup Count for Motor (H44)



2nd Startup Counter for Motor (A52)

1st Cumulative Motor Run Time (H94)

2nd Cumulative Motor Run Time (A51)

User Preference Dataset Protection Function Selection (H194)

Monitor Exclusive Parameters (M, W Parameters)

- Save user preference dataset by the following procedure. To change User Preference Dataset Registration (H193) and User Preference Dataset Protection Function Selection (H194), the “ key +  /  key” must be pressed simultaneously with each of the parameter values displayed.  
Step 1: Set “0: Unprotected” (default value) to User Preference Dataset Protection Function Selection (H194).

Step 2: Select User Preference Dataset Registration (H193). “0: Disable” is displayed as the value of H193.

Step 3: When User Preference Dataset Registration (H193) is set to “1: Protected,” registration of the user preference dataset is started. During registration, “SAVE” is displayed, and the value returns to 0 when registration is completed.

Step 4: To protect the user preference dataset, set “1: Protected (save prohibited)” to User Preference Dataset Protection Function Selection (H194).

- To set all user preference datasets to the factory defaults, initialize parameters by Data Initialization (H03) “1: Initialize all parameters,” and then register the datasets by User Preference Dataset Registration (H193).

## 5-2 Setting V/f Control

### 5-2-1 Motor Control Method (V/f Characteristics)

- V/f control is a method of controlling a motor by setting the output voltage and frequency of the inverter as V/f characteristics. This is effective for using the inverter easily.
- Set 0 and 3 at Drive Control Selection and select the V/f characteristics (output voltage and output frequency).

Parameter No.	Function name	Data	Default data	Unit
F42/A14	1st Drive Control Selection/2nd Drive Control Selection*1	0: IM V/f control 3: IM V/f control with speed sensor	0	-
F37/A13	1st V/f Characteristics Selection/2nd V/f Characteristics Selection	0: Variable torque load 1: Constant torque load	1	-

\*1. To enable switching to the 1st and 2nd control, allocate "12: SET (2nd control)" to either of input terminal [DI1] to [DI7].

#### V/f Control (Induction Motor) (F42/A14 = 0)

V/f control outputs the voltage and frequency according to a preset V/f pattern to operate the motor. Also, slip compensation function enabled/disabled can be switched by Slip compensation Function Selection (H442). For details on slip compensation, refer to 5-2-3 *Slip Compensation* on page 5-16.

#### V/f Control with Speed Sensor (Induction Motor) (F42/A14 = 3)

When a load is applied to an induction motor, slip occurs according to characteristics of the motor and this results in a drop in motor rotation speed.

With V/f control with speed sensor, the motor rotation speed is detected by an encoder mounted on the motor shaft, and the slip frequency is compensated by PI control so that the motor rotation speed matches the speed equivalent to the instructed speed. As a result, the speed control accuracy of the motor is improved.

#### Constant Torque Characteristics (F37/A13 = 1)

This setting is suitable for cart, conveyor, overhead traveling crane, and other applications where a torque is required, independent of the motor rotation speed.

It enables the output of a constant torque based on the frequency, according to the V/f characteristics that represent the proportional relationship between the output frequency and the output voltage.

For the base frequency, set the rated frequency of the motor.

For the maximum frequency, set the highest frequency at which control is performed on the inverter. Note that this must be within the maximum frequency of the motor.

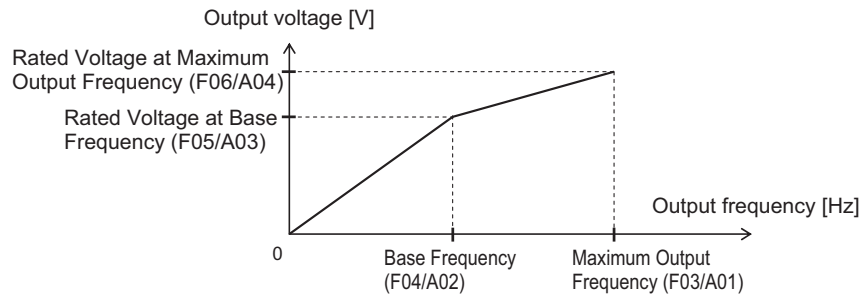

## Reducing Torque Characteristics (F37/A13 = 0)

This setting is suitable for fan, pump, and other applications that do not require large torque at low speeds.

It provides high efficiency, reduced noise and vibration as the output voltage is reduced in the low speed range.

By using the non-linear V/f function, a sufficient startup torque can also be secured as constant torque characteristics up to specified speeds.

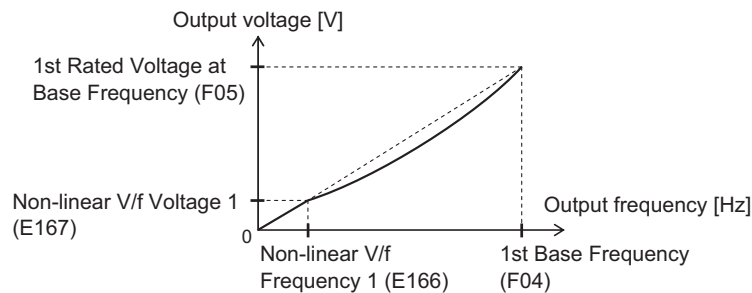

Reducing torque characteristics using non-linear V/f

Reducing torque characteristics are characteristics to the power of two.

## Broken Line V/f Function

- With the non-linear V/f function, V/f characteristics at a total of nine points can be configured as desired by setting the voltage and frequency of seven points in addition to base voltage/frequency and maximum voltage/frequency. When the non-linear V/f function is not used, set "0.0" to the non-linear V/f frequency 1 to 7 that is not to be used.
- Frequency is not in parameter No. order but in order of the size of the set value. (Refer to the figure below.)
- The non-linear V/f function can be jointly used with torque boost, reducing torque characteristics and automatic energy saving operation.

Parameter No.	Function name	Data	Description	Default data	Unit
E166	Non-linear V/f Frequency 1	0.0: Disable 0.1 to 590.0 Hz	Sets the frequency at each break point.	0.0	Hz
E168	Non-linear V/f Frequency 2				
E170	Non-linear V/f Frequency 3				
E172	Non-linear V/f Frequency 4				
E174	Non-linear V/f Frequency 5				
E176	Non-linear V/f Frequency 6				
E178	Non-linear V/f Frequency 7				
E167	Non-linear V/f Voltage 1	0 to 240 V (200-V class) 0 to 500 V (400-V class)	Sets the voltage at each break point.	0	V
E169	Non-linear V/f Voltage 2				
E171	Non-linear V/f Voltage 3				
E173	Non-linear V/f Voltage 4				
E175	Non-linear V/f Voltage 5				
E177	Non-linear V/f Voltage 6				
E179	Non-linear V/f Voltage 7				

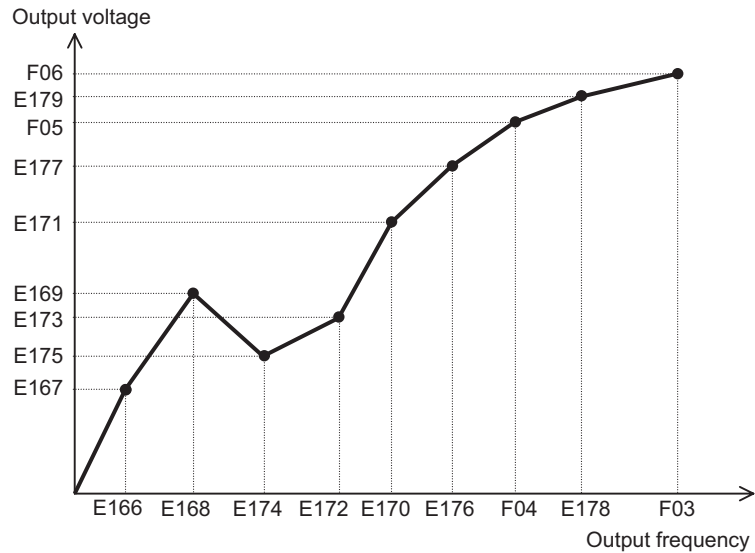

### 5-2-2 Load Mode Selection

Select either of the heavy load mode (HHD/HD) or the light load mode (HND/ND) according to the application.

Parameter No.	Function name	Data	Default data	Unit
F80	Load Mode Selection	0: HHD 1: HND 3: HD (only for 400 V) 4: ND (only for 400 V)	0	-
Related function		F42/A14, F09/A05, F44/E147, F26, F21/A10		

- Load modes that can be selected differ depending on the voltage specifications and capacity of the inverter.

	HHD F80 = 0	HND F80=1	HD F80=3	ND F80=4
Three-phase 200 V full capacity	OK	OK	-	-
Three-phase 400 V full capacity	OK	OK	OK	OK
Single-phase 200 V (2.2 k or less)	OK	OK	-	-
Single-phase 200 V (3.7 kW)	OK	-	-	-

- For loads (such as fans and pumps) that do not require frequent use of the inverter above the rated torque, the light load mode can be selected. The rated current of the inverter increases above that of the heavy load mode, which enables the inverter to drive a motor one size larger. For details on rated current specifications, refer to *1-3-1 Standard Specifications* on page 1-11. The overload capacity differs as shown in the following table on each specification type.

F80 data	Specification type		Continuous rated current level	Ambient temperature	Overload capacity
0	Heavy load mode	HHD	Motor of same capacity as inverter capacity can be driven	Up to 50°C	150% 1 min 200% 0.5 s
3 (only for 400 V)		HD	Motor of capacity one size larger than the inverter capacity can be driven	Up to 40°C	150% 1 min
1	Light load mode	HND	Motor of capacity one size larger than the inverter capacity can be driven	Up to 50°C	120% 1 min
4 (only for 400 V)		HD	Motor of capacity one to two sizes larger than the inverter capacity can be driven	Up to 40°C	120% 1 min

## Related Parameters

- Some parameters are restricted by changing the setting of Load Mode Selection (F80).
- **When Drive Control Selection (F42/A14) = 0 to 6 (induction motor)**
  - The set values of the following parameters are overwritten with the following values according to the new settings after changing Load Mode Selection (F80).
    - Manual Torque Boost Voltage (F09/A05), Overload Protect Level (F44/E147)
  - The upper limit values of the following parameters change according to the new settings after changing Load Mode Selection (F80). When the set values exceed the upper limit, they are overwritten with the upper limit.
    - Carrier Frequency (F26), DC Injection Braking Level (F21/A10)

Power supply	Model	Capacity [kW]	Manual Torque Boost Voltage (F09/A05)				Overload Protect Level (F44/E147)				Carrier Frequency (F26)				DC Injection Braking Level (F21/A10)			
			Set value				Set value				Maximum value (*1)				Maximum value (*1)			
			Load Mode Selection (F80)				Load Mode Selection (F80)				Load Mode Selection (F80)				Load Mode Selection (F80)			
			0: H H D	1: H N D	3: H D	4: N D	0: H H D	1: H N D	3: H D	4: N D	0: H H D	1: H N D	3: H D	4: N D	0: H H D	1: H N D	3: H D	4: N D
Three-phase 200 V	3G3M1-A2001	0.1	8.4	6.7	-	-	180	130	-	-	16	16	-	-	100	80	-	-
	3G3M1-A2002	0.2	8.4	6.7	-	-	180	130	-	-	16	16	-	-	100	80	-	-
	3G3M1-A2004	0.4	7.1	4.0	-	-	180	130	-	-	16	16	-	-	100	80	-	-
	3G3M1-A2007	0.75	3.8	2.6	-	-	180	130	-	-	16	16	-	-	100	80	-	-
	3G3M1-A2015	1.5	3.0	2.4	-	-	180	130	-	-	16	16	-	-	100	80	-	-
	3G3M1-A2022	2.2	2.5	2.1	-	-	180	130	-	-	16	10	-	-	100	80	-	-
	3G3M1-A2037	3.7	2.4	2.0	-	-	180	130	-	-	16	10	-	-	100	80	-	-
	3G3M1-A2055	5.5	1.9	1.9	-	-	180	130	-	-	16	16	-	-	100	80	-	-
	3G3M1-A2075	7.5	1.8	1.8	-	-	180	130	-	-	16	16	-	-	100	80	-	-
	3G3M1-A2110	11	1.3	1.3	-	-	180	130	-	-	16	16	-	-	100	80	-	-
	3G3M1-A2150	15	1.2	1.2	-	-	180	130	-	-	16	16	-	-	100	80	-	-
	3G3M1-A2185	18.5	0.9	0.9	-	-	160	130	-	-	16	16	-	-	100	80	-	-



Power supply	Model	Capacity [kW]	Manual Torque Boost Voltage (F09/A05)				Overload Protect Level (F44/E147)				Carrier Frequency (F26)				DC Injection Braking Level (F21/A10)			
			Set value				Set value				Maximum value (*1)				Maximum value (*1)			
			Load Mode Selection (F80)				Load Mode Selection (F80)				Load Mode Selection (F80)				Load Mode Selection (F80)			
			0: H H D	1: H N D	3: H D	4: N D	0: H H D	1: H N D	3: H D	4: N D	0: H H D	1: H N D	3: H D	4: N D	0: H H D	1: H N D	3: H D	4: N D
Three-phase 400 V	3G3M1-A4004	0.4	7.1	4.0	7.1	4.0	180	130	160	130	16	16	16	10	100	80	80	60
	3G3M1-A4007	0.75	3.8	2.6	3.8	2.6	180	130	160	130	16	16	16	10	100	80	80	60
	3G3M1-A4015	1.5	3.0	2.4	3.0	2.4	180	130	160	130	16	16	16	10	100	80	80	60
	3G3M1-A4022	2.2	2.5	2.1	2.5	2.1	180	130	160	130	16	16	16	10	100	80	80	60
	3G3M1-A4030	3.0	2.5	2.1	2.5	2.1	180	130	160	130	16	16	16	10	100	80	80	60
	3G3M1-A4040	4.0	2.4	2.0	2.4	2.0	180	130	160	130	16	16	16	10	100	80	80	60
	3G3M1-A4055	5.5	1.9	1.9	1.9	1.9	180	130	160	130	16	16	16	10	100	80	80	60
	3G3M1-A4075	7.5	1.8	1.8	1.8	1.8	180	130	160	130	16	16	16	10	100	80	80	60
	3G3M1-A4110	11	1.3	1.3	1.3	1.3	180	130	160	130	16	16	16	10	100	80	80	60
	3G3M1-A4150	15	1.2	1.2	1.2	1.2	180	130	160	130	16	16	16	10	100	80	80	60
	3G3M1-A4185	18.5	0.9	0.9	0.9	0.9	160	130	160	130	16	16	16	10	100	80	80	60
	3G3M1-A4220	22	0.9	0.9	0.9	0.9	160	130	160	130	16	10	10	6	100	80	80	60
Single-phase 200 V	3G3M1-AB001	0.1	8.4	6.7	-	-	180	130	-	-	16	10	-	-	100	80	-	-
	3G3M1-AB002	0.2	8.4	6.7	-	-	180	130	-	-	16	10	-	-	100	80	-	-
	3G3M1-AB004	0.4	7.1	4.0	-	-	180	130	-	-	16	10	-	-	100	80	-	-
	3G3M1-AB007	0.75	3.8	2.6	-	-	180	130	-	-	16	10	-	-	100	80	-	-
	3G3M1-AB015	1.5	3.0	2.4	-	-	180	130	-	-	16	10	-	-	100	80	-	-
	3G3M1-AB022	2.2	2.5	2.1	-	-	180	130	-	-	16	10	-	-	100	80	-	-
	3G3M1-AB037	3.7	2.4	-	-	-	180	-	-	-	16	-	-	-	100	-	-	-

● **When Drive Control Selection (F42) = 15, 16 (synchronous motor)**

- The set values of the following parameters are overwritten with the following values according to the new settings after changing Load Mode Selection (F80).
  - Manual Torque Boost Voltage (F09)

Power supply	Model	Capacity [kW]	Manual Torque Boost Voltage (F09)			
			Set value			
			Load Mode Selection (F80)			
			0: HHD	1: HND	3: HD	4: ND
Three-phase 200 V	3G3M1-A2001	0.1	8.4	6.7	-	-
	3G3M1-A2002	0.2	8.4	6.7	-	-
	3G3M1-A2004	0.4	7.1	4.0	-	-
	3G3M1-A2007	0.75	6.8	3.5	-	-
	3G3M1-A2015	1.5	6.8	4.9	-	-
	3G3M1-A2022	2.2	6.8	4.5	-	-
	3G3M1-A2037	3.7	5.5	4.1	-	-
	3G3M1-A2055	5.5	4.9	3.4	-	-
	3G3M1-A2075	7.5	4.4	2.7	-	-
	3G3M1-A2110	11	3.5	2.1	-	-
	3G3M1-A2150	15	2.8	1.6	-	-
Three-phase 400 V	3G3M1-A4004	0.4	7.1	4.0	7.1	4.0
	3G3M1-A4007	0.75	6.8	3.5	6.8	3.5
	3G3M1-A4015	1.5	6.8	4.9	6.8	4.9
	3G3M1-A4022	2.2	6.8	4.5	6.8	4.5
	3G3M1-A4030	3.0	6.8	4.5	6.8	4.5
	3G3M1-A4040	4.0	5.5	4.1	5.5	4.1
	3G3M1-A4055	5.5	4.9	3.4	4.9	3.4
	3G3M1-A4075	7.5	4.4	2.7	4.4	2.7
	3G3M1-A4110	11	3.5	2.1	3.5	2.1
	3G3M1-A4150	15	2.8	1.6	2.8	1.6
	3G3M1-A4185	18.5	2.2	1.3	2.2	1.3
3G3M1-A4220	22	2.2	1.1	2.2	1.1	
Single-phase 200 V	3G3M1-AB001	0.1	8.4	6.7	-	-
	3G3M1-AB002	0.2	8.4	6.7	-	-
	3G3M1-AB004	0.4	7.1	4.0	-	-
	3G3M1-AB007	0.75	6.8	3.5	-	-
	3G3M1-AB015	1.5	6.8	4.9	-	-
	3G3M1-AB022	2.2	6.8	4.5	-	-
	3G3M1-AB037	3.7	5.5	-	-	-

### 5-2-3 Slip Compensation

The slip compensation function calculates the torque generated by the motor to infer the slip amount. As a result of this calculation, the drop in motor rotation speed can be compensated for to suppress the drop in motor rotation speed. This is useful for improving the speed control accuracy of the motor. To enable the slip compensation function, select "0: V/f control" or "3: V/f control with speed sensor" at Drive Control Selection (F42/A14), then set 1 at Slip compensation Function Selection (H442), and set

the conditions for enabling the slip compensation function to Slip Compensation Operating Conditions Selection (H68/A40).

Parameter No.	Function name	Data	Default data	Unit
H442	Slip compensation Function Selection	0: Disable 1: Enable	0	-
H68/A40	1st Slip Compensation Operating Conditions Selection/2nd Slip Compensation Operating Conditions Selection* <sup>1</sup>	0: Enable during acceleration/ deceleration, enable at base frequency or higher 1: Disable during acceleration/ deceleration, enable at base frequency or higher 2: Enable during acceleration/ deceleration, disable at base frequency or higher 3: Disable during acceleration/ deceleration, disable at base frequency or higher	0	-
P09/A23* <sup>2</sup>	1st Slip Compensation Gain for Driving/2nd Slip Compensation Gain for Driving* <sup>1</sup>	0.0 to 200.0 %	100.0	%
P10/A24	1st Slip Compensation Response Time/2nd Slip Compensation Response Time* <sup>1</sup>	0.01 to 10.00 s	0.12	s
P11/A25* <sup>2</sup>	1st Slip Compensation Gain for Braking/2nd Slip Compensation Gain for Braking* <sup>1</sup>	0.0 to 200.0 %	100.0	%
P12/A26* <sup>2</sup>	1st Rated Slip Frequency/2nd Rated Slip Frequency* <sup>1</sup>	0.00 to 15.00 Hz	Dependent on capacity	Hz

\*1. To enable switching to the 1st and 2nd control, allocate "12: SET (2nd control)" to either of input terminal [DI1] to [DI7].

\*2. When 0.0% or 0.00 Hz is set to one of P09/A23, P11/A25 and P12/A26, slip compensation is disabled.

Details of 1st Slip Compensation Operating Conditions Selection (H68) and 2nd Slip Compensation Operating Conditions Selection (A40) are as shown in the table below.

H68/A40 Data	Motor operation state		Frequency range	
	At acceleration/ deceleration	At constant speed	Base frequency or less	Base frequency or more
0	Enable	Enable	Enable	Enable
1	Disable	Enable	Enable	Enable
2	Enable	Enable	Enable	Disable
3	Disable	Enable	Enable	Disable

- For Slip compensation gain for driving (P09/A23)/Slip compensation response time (P10/A24)/Slip compensation gain for braking (P11/A25) slip compensation gain for driving and slip compensation gain for braking, adjust the compensation amount for when slip compensation is performed and the slip amount in the internal calculation. These can be set individually in the driving mode and the

braking mode. The rated slip frequency is archived when set to 100%. When overcompensation (100% or higher) is set in slip compensation, hunting sometimes occurs. So, check this on an actual inverter.

The slip compensation response time determines the response when slip compensation is performed. Basically, there is no need to change the setting.

- Rated slip frequency (P12/A26)

Set the rated slip frequency of the motor. This is also automatically set by executing auto-tuning.

$$\text{Rated slip frequency (Hz)} = \frac{\text{Synchronous speed} - \text{Rated speed}}{\text{Synchronous speed}} \times \text{Base frequency}$$

## 5-3 Motor Parameter Settings

### 5-3-1 Induction Motor Basic Settings

When running an induction motor, set the following parameters to match the rated value of the motor used and the design values of the machinery.

Parameter No.	Function name	Data	Default data	Unit
F04 A02	1st Base Frequency 2nd Base Frequency *1	5.0 to 590.0 Hz	50.0	Hz
F05 A03	1st Rated Voltage at Base Frequency 2nd Rated Voltage at Base Frequency *1	80 to 240 V (200-V class) 160 to 500 V (400-V class)	200	V
F03 A01	1st Maximum Output Frequency 2nd Maximum Output Frequency *1	5.0 to 590.0 Hz	60.0	Hz

\*1. To enable switching to the 1st and 2nd control, allocate "12: SET (2nd control)" to either of input terminal [DI1] to [DI7].

### 5-3-2 Base Frequency and Maximum Frequency of Motor

To configure the V/f control characteristics output to the motor, set the base frequency and maximum frequency of your motor.

For the base frequency, set the rated frequency of the motor (the frequency listed on the motor rating nameplate).

For the maximum frequency, set the highest frequency required for your application. However, do not exceed the maximum rotation speed of the motor.

Then, set the motor rated voltage to 1st Rated Voltage at Maximum Output Frequency (F06)/2nd Rated Voltage at Maximum Output Frequency (A04).

Parameter No.	Function name	Data	Default data	Unit
F04	1st Base Frequency	5.0 to 590.0Hz	50.0	Hz
A02	2nd Base Frequency*1		50.0	Hz
F03	1st Maximum Output Frequency	5.0 to 590.0Hz	60.0	Hz
A01	2nd Maximum Output Frequency*1		60.0	Hz
F05	1st Rated Voltage at Base Frequency	80 to 240 V (200-V class) 160 to 500 V (400-V class)	Dependent on capacity	V
A03	2nd Rated Voltage at Base Frequency*1		Dependent on capacity	V

Parameter No.	Function name	Data	Default data	Unit
F06	1st Rated Voltage at Maximum Output Frequency	80 to 240 V (200-V class) 160 to 500 V (400-V class)	Dependent on capacity	V
A04	2nd Rated Voltage at Maximum Output Frequency <sup>*1</sup>		Dependent on capacity	V

\*1. To enable switching to the 1st and 2nd control, allocate "12: SET (2nd control)" to either of input terminal [DI1] to [DI7].

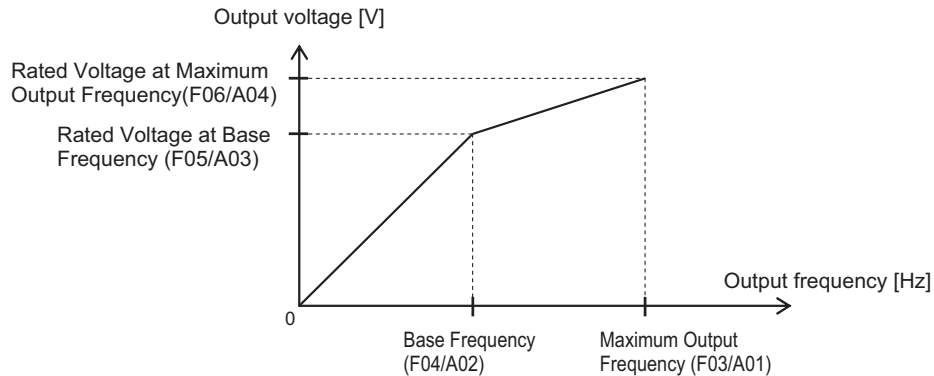

#### Precautions for Correct Use

- For these motors, check the rated motor current and select an appropriate inverter based on the rated current of the inverter.
- Do not set the base frequency to lower than the motor rated frequency. Doing so may cause overload or motor burnout.
- Do not select a motor incoming voltage higher than the motor rated voltage. Doing so may cause an overload or motor burnout.

### 5-3-3 Motor Electronic Thermal Function

The motor electronic thermal function prevents the motor from overloading and burning. In addition, M1 has a braking resistor electronic thermal function. (Refer to 5-12-2 *Braking Resistor Electronic Thermal Function* on page 5-75.)

- The motor electronic thermal function calculates the electronic thermal calculated value for motor protection based on the output current of the inverter. The status of the electronic thermal function can be checked by the monitor of electronic thermal overload protection for motor (monitor mode: 5\_62). When 100% is reached in the percentage display, motor overload (alarm OL1 or OL2) is detected.
- The motor electronic thermal function sets Motor Electronic Thermal Level (F11/A07) and Motor Electronic Thermal Characteristic Selection (F10/A06), and Motor Electronic Thermal Time Constant (F12/A08).
- When Motor Electronic Thermal Overload Protection Data Retention (H89) is set to 1, the electronic thermal cumulative value and thermal cumulative value of the overload early warning are saved in the EEPROM when an insufficient voltage state has occurred, and, when the power is next turned ON, EEPROM saved values are used as the defaults for cumulative values.

Parameter No.	Function name	Data	Default data	Unit
F11/A07	1st Motor Electronic Thermal Level/2nd Motor Electronic Thermal Level *1	0.00; 0.01 to 2000 0.00: Disable 0.01 to 2000 A  *Setting range is from 1%(HHD) to 135%(ND) of inverter rated current.	22.5	A
F10/A06	1st Motor Electronic Thermal Characteristic Selection/2nd Motor Electronic Thermal Characteristic selection *1	1 to 2 1: For a general-purpose motor with shaft-driven cooling fan 2: For an inverter-driven motor non-ventilated motor or motor with separately powered cooling fan	1	-
F12/A08	1st Motor Electronic Thermal Time Constant/2nd Motor Electronic Thermal Time Constant *1	0.5 to 75.0	5	min
M59	Motor Electronic Thermal Monitor	0.0 to 100.0	0	%
H89	Motor Electronic Thermal Overload Protection Data Retention	0; 1 0: Disable 1: Enable	0	-
Related function		Output terminal functions (OL1, OL2)		

\*1. To enable switching to the 1st and 2nd control, allocate "12: SET (2nd control)" to either of input terminal [DI1] to [DI7].

## Motor Electronic Thermal Level (F11/A07)

- Set the operation level of the electronic thermal for motor protection. To not use this function, set 0.00.
- Normally, set to the motor continuous allowable current (generally, about 1.0 to 1.1 times the motor rated current) when the motor is run at base frequency.

## Motor Electronic Thermal Characteristic Selection (F10/A06)

- Select the characteristics of the motor cooling system.
- **When Motor Electronic Thermal Characteristic Selection (F10/A06) = 1: For a general-purpose motor with shaft-driven cooling fan**
  - The figure below shows the electronic thermal operation characteristics. Characterization factors  $\alpha 1$  to  $\alpha 3$  and their switching frequencies  $f 2$  and  $f 3$  differ according to the characteristics of the motor.

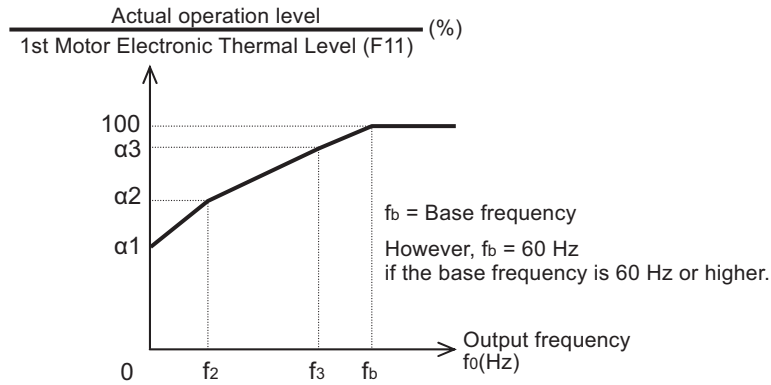

- The following shows each factor that is set according to the motor characteristics selected by motor capacity and motor type (induction motor/PM motor).

(Induction motor (IM))

Motor capacity	Thermal time constant t (factory default)	Thermal time constant setting reference current value I <sub>max</sub>	Characterization factor switching frequency		Characterization factor			
			f <sub>2</sub>	f <sub>3</sub>	α1	α2	α3	
0.4, 0.75 kW	5 min	Continuous allowable current value × 150%	5 Hz	7 Hz	75%	85%	100%	
1.5 to 3.7 kW					85%	85%	100%	
5.5 to 11 kW					6 Hz	90%	95%	100%
15 kW					7 Hz	85%	85%	100%
18.5, 22 kW					5 Hz	92%	100%	100%
30 to 45 kW	10 min		Continuous allowable current value × 150%	Base frequency × 33%	Base frequency × 83%	54%	85%	95%
55 to 90 kW						51%	95%	95%
110 kW min.						53%	85%	90%

(Synchronous motor (PM))

Motor capacity	Thermal time constant t (factory default)	Thermal time constant setting reference current value I <sub>max</sub>	Characterization factor switching frequency		Characterization factor		
			f <sub>2</sub>	f <sub>3</sub>	α1	α2	α3
0.2 to 22 kW	5 min	Continuous allowable current value × 150%	Base frequency × 33%	Base frequency × 33%	69%	90%	90%
30 to 45 kW	10 min			Base frequency × 33%	54%	85%	95%
55 to 90 kW				Base frequency × 83%	51%	95%	95%
110 kW min.				Base frequency × 83%	53%	85%	90%

● **When Motor Electronic Thermal Characteristic Selection (F10/A06) = 2: For an inverter-driven motor non-ventilated motor or motor with separately powered cooling fan**

- The operation level is a constant value without decrease that is set at Motor Electronic Thermal Level (F11/A07) as there is no drop in the cooling effectiveness by output frequency.



## Motor Electronic Thermal Time Constant (F12/A08)

- Set the thermal time constant of the motor. Set the electronic thermal operating time for when a current of 150% of the operation level set at Motor Electronic Thermal Level (F11/A07) flows continuously. The thermal time constant of a general motor is 5 minutes for 22kW or less (factory default).

(Example) When the data of F12/A08 is set to 5 (5 minutes)

When a current 150% of the overload detection level set as shown in the figure below flows for 5 minutes, the motor overload (alarms OL1/OL2) protection function operates. Also, for 120%, the motor overload protection function operates after approx. 12.5 minutes.

The time that an alarm actually is generated is shorter than the set data as the time from when the continuous allowable current (100%) is exceeded up to when the 150% level is reached also is taken into consideration.

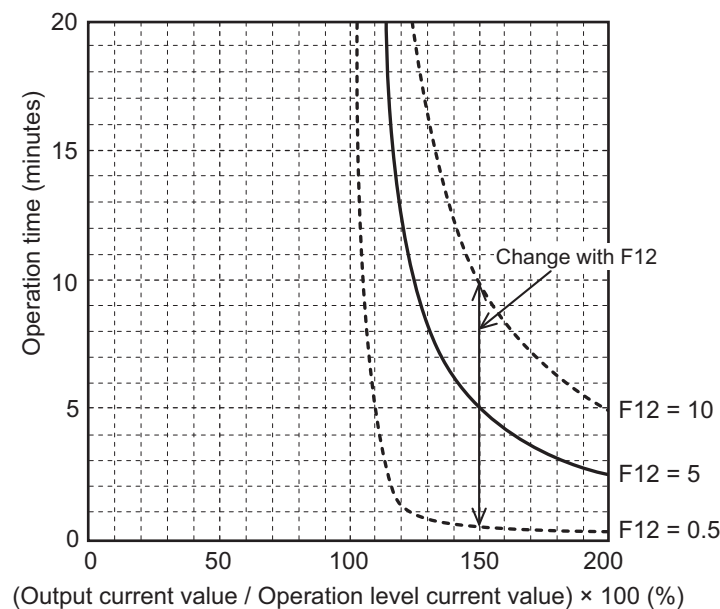

## Motor Electronic Thermal Warning

Use this function to output a warning signal before the motor electronic thermal function executes an overload protection. The electronic thermal warning operates at or above the current value set in the Overload early warning 2 Level (OL2) (E34). Generally, set to around 80% to 90% of the current value of the Motor Electronic Thermal Level (F11/A07). The temperature characteristics of the motor are set in Motor Electronic Thermal Characteristic Selection (F10/A06) or Motor Electronic Thermal Time Constant (F12/A08).

Parameter No.	Function name	Data	Default data	Unit
E20, E21, E27	Output Terminal [DO1] Function Selection, Output Terminal [DO2] Function Selection, Output Terminal [ROA, ROB] Function Selection	7: THM (Electronic thermal warning)	-	-

Parameter No.	Function name	Data	Default data	Unit
E34	Overload early warning 2 Level (OL2)	0.00; 0.01 to 176.0 0.00: Disable 0.01 to 176.0 A  *Setting range is from 1%(HHD) to 200%(ND) of inverter rated current.	21	A

## 5-4 RUN command

### 5-4-1 RUN Command Selection

Select the input method for the RUN command.

Parameter No.	Function name	Data	Default data	Unit
F02 E102	1st RUN Command Selection 2nd RUN Command Selection *1	0 to 5 0: Operator (Direction of rotation input: terminal block) 1: External signal (FW or RV) 2: Operator (Forward rotation) 3: Operator (Reverse rotation) 4: RS-485 communication 5: Do not use	2	-
Related functions		Input Terminal [DI6] Function Selection (E98), Input Terminal [DI7] Function Selection (E99) Refer to 5-9-1 <i>Input Terminal Functions</i> on page 5-51. Operation command (S06)*2		

- \*1. To enable switching to the 1st and 2nd control, allocate "12: SET (2nd control)" to either of input terminal [DI1] to [DI7].
- \*2. When "4: RS-485 communication" is selected at 1st RUN Command Selection (F02)/2nd RUN Command Selection (E102), the FW command is executed by setting bit 0 of Operation command (S06) to ON, and the RV command is executed by setting bit 1 to ON. These parameters are exclusively for reading and writing via the RS-485 interface. These parameters are not displayed on the Operator. To check these parameters, use Sysmac Studio.

The operation method for data selected at 1st RUN Command Selection (F02)/2nd RUN Command Selection (E102) is as follows.

Data	Operation method
0	When the <input type="button" value="RUN"/> key on the Operator is pressed, forward rotation is performed when the FW terminal turns ON. Reverse rotation is performed when the RV terminal turns ON. When the <input type="button" value="STOP"/> key is pressed, operation is stopped.
1	Forward rotation is performed when the FW terminal turns ON regardless of the <input type="button" value="RUN"/> key on the Operator. Reverse rotation is performed when the RV terminal turns ON. Operation stops when both the FW and RV terminals are OFF or both are ON.
2	When the <input type="button" value="RUN"/> key on the Operator is pressed, forward rotation is performed. When the <input type="button" value="STOP"/> key is pressed, operation is stopped.
3	When the <input type="button" value="RUN"/> key on the Operator is pressed, reverse rotation is performed. When the <input type="button" value="STOP"/> key is pressed, operation is stopped.
4	When bit 00:FW in Operation command (S06) is turned ON via RS-485 communication, forward rotation is performed. When bit 01:RV is turned ON, reverse rotation is performed. When both are OFF or ON, operation is stopped.

- When "0: Operator (Direction of rotation input: terminal block)" and "1: External signal (Digital input)" are selected at RUN Command Selection (F02/E102), allocate "98: FW (forward rotation)" and "99: RV (reverse rotation)" to each of Input Terminal [DI6] Function Selection (E98) and Input Terminal

[DI7] Function Selection (E99). Operation stops when both the FW and RV terminals are ON or OFF.

- When “1: External signal (Digital input)” is selected at RUN Command Selection (F02/E102), 3-wire input is possible. Refer to *3-wire Input Function (FW, STP, F/R)* on page 5-56.
- The RUN command from the Operator can be forcibly enabled via input terminals. Refer to *7-7-2 Forced Operator Function (OPE)* on page 7-75. The RUN command from an input terminal can also be forcibly enabled via input terminals. Refer to *7-7-3 Forced Terminal Block Function (FTM)* on page 7-75.
- When the inverter is outputting to the motor, operation is in progress and the RUN-LED lights. Lights during deceleration after RUN command OFF. Goes out while the RUN command is ON at frequency reference 0 Hz as there is no output. When zero speed control is being executed, this lights as the inverter outputs even when the frequency reference is 0 Hz.

### ● Operation example



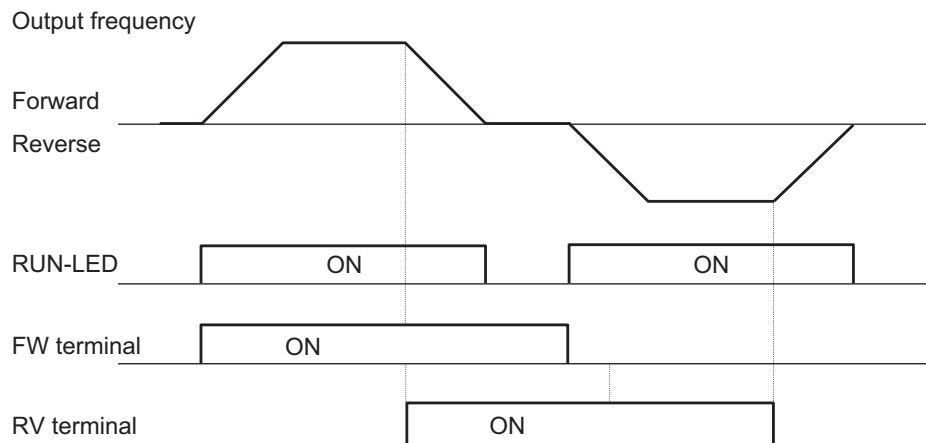

- The following shows an example of operation by forward command FW input and reverse command RV input when “1: External signal (Digital input)” is selected at RUN Command Selection (F02/E102).



## 5-5 Frequency Reference

### 5-5-1 Frequency Reference Selection

- Select the input method for the frequency reference.

Parameter No.	Function name	Data	Default data	Unit
F01	1st Frequency Reference Selection	0 to 15	0	
C30	2nd Frequency Reference Selection*1	0: Operator (  and  keys) (output frequency not inherited) 1: Analog Voltage Input (Input Terminal[A11]) 2: Analog Current Input (Input Terminal[A12](AII)) 3: Analog Voltage Input (Input Terminal[A11]) + Analog Current Input (Input Terminal[A12](AII)) 5: Analog Voltage Input (Input Terminal[A12](AIV)) 7: UP/DOWN control 8: Digital Operator (  and  keys) (balancelessbumpless switching available) 10: Pattern operation 12: Pulse train input 13: Calculation result 14: RS-485 communication 15: Do not use	2	-
S06	Operation command	0000 to FFFF hex Bit1: REV Bit0: FWD	0	
Related functions		Input Terminal [DI1] Function Selection to Input Terminal [DI7] Function Selection (E01 to E05, E98, E99) Refer to 5-9-1 <i>Input Terminal Functions</i> on page 5-51.		

\*1. To enable switching to the 1st and 2nd control, allocate "12: SET (2nd control)" to either of input terminal [DI1] to [DI7].

The frequency reference method for data selected at 1st Frequency Reference Selection (F01) and 2nd Frequency Reference Selection (C30) is as follows.





Data	Frequency reference method
0	Sets the frequency reference via the Operator. When 1st control is selected, the setting value is reflected in 1st Frequency Reference/1st Multi-step Frequency Reference 0 (C99). When 2nd control is selected, the setting value is reflected in 2nd Frequency Reference/2nd Multi-step Frequency Reference 0 (CE109).
1	Sets the frequency reference via the analog voltage input (input terminal [A11]).
2	Sets the frequency reference via the analog current input (input terminal [A12](AII)).
3	Sets the value obtained by adding the analog voltage input (input terminal [A11]) and analog current input (input terminal [A12](AII)) as the frequency reference.







Data	Frequency reference method
5	Sets the frequency reference via the analog voltage input (input terminal [AI2] (AIV)).
7	Sets the frequency reference via the UP and DOWN terminals.
8	Sets the frequency reference via the Operator. When "8" is set to Frequency Reference Selection (F01/C30), the frequency currently being output is inherited as the frequency reference value.
10	Sets the frequency reference via Pattern Operation / Timed Operation.
12	Sets the frequency reference via pulse train input.
13	The result of calculation of the frequency calculation function is set as the frequency reference.
14	Sets the frequency reference via RS-485 communication.

- The forced operation function and forced terminal block function are given priority over the frequency reference selected at Frequency Reference Selection (F01/C30). For details, refer to 7-7-2 *Forced Operator Function (OPE)* on page 7-75 and 7-7-3 *Forced Terminal Block Function (FTM)* on page 7-75.

## Command on the Operator (Frequency Reference Selection (F01/C30) = "0" "8")

Sets the frequency reference via the Operator.



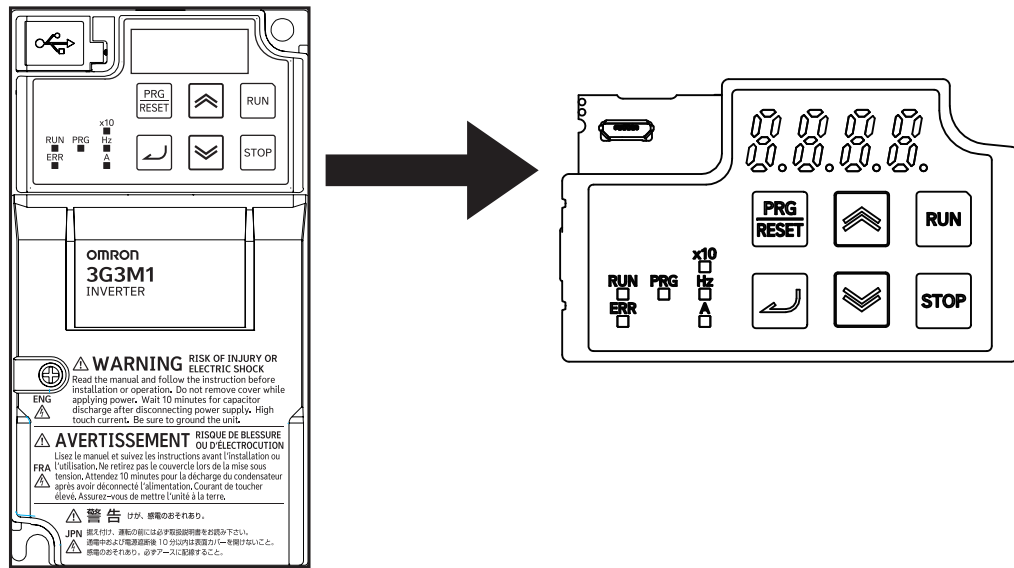

Parameter No.	Function name	Data	Default data	Unit
F01	Frequency Reference Selection	0: Operator (  and  keys) 8: Digital Operator (  and  keys) (balancelessbumpless switching available)	0	-

- The display when the power is ON can be set at Operator Display when Stopped Selection (E44). (Refer to 7-7-4 *Initial Screen Selection* on page 7-76.)
- When the Operator is in the program mode or the alarm mode, the frequency reference cannot be changed by the  key or  key. When in the program mode or alarm mode, enter the RUN mode. (Refer to 3-1-2 *Key Operation Method* on page 3-3.)
- When the  key or  key is pressed, the set frequency is displayed, and the lowermost digit of the set frequency flashes.
- The set frequency can be changed by pressing the  key or  key again. The setting value is reflected in 1st Frequency Reference/1st Multi-step Frequency Reference 0 (C99), 2nd Frequency Reference/2nd Multi-step Frequency Reference 0 (E109) according to the 1st/2nd control selection.
- When the power is next turned ON again, operation is possible from the frequency reference that was active when the power was last turned OFF. (E64 = 0: Factory default)



- When the power is turned ON, operation starts from the set value that was saved before the power was last turned OFF. The timing that the set value is saved can be selected at Operator Reference Frequency Saving Selection (E64).

Parameter No.	Function name	Data	Default data	Unit
E64	Operator Reference Frequency Saving Selection	0; 1 0: Automatic saving (when main power is turned OFF) 1: Saving by Up/Down key and  key	0	-

- When E64 = 0, the frequency reference that was set when the power was turned OFF is inherited when the power is turned ON again.
- When E64 = 1, the frequency reference that was saved by pressing the  key when the frequency reference was changed is inherited. When the  key is pressed without pressing the  key, and approximately four seconds of inactivity pass, the frequency reference is considered as not having been confirmed, and operation starts from the value when the  key was pressed when the power is next turned ON.
- When “8” is set to the data of Operator Reference Frequency Saving Selection (F01), and when a frequency setting is switched to by the Operator from a frequency setting means other than the Operator, the frequency setting before the value was switched is inherited as the default value of the frequency reference according to the Operator that switched the value. Operation is shockless even if the frequency setting is switched by this function.

## Command Using Analog Voltage Input or Analog Current Input (Frequency Reference Selection (F01/C30) = “1” “2” “3” “5”)

Set value	Description
1	Sets the frequency reference via the analog voltage input (input terminal [AI1]).
2	Sets the frequency reference via the analog current input (input terminal [AI2][AI]).

Set value	Description
3	Sets the value obtained by adding the analog voltage input (input terminal [AI1]) and analog current input (input terminal [AI2](AI)) as the frequency reference.
5	Sets the frequency reference via the analog voltage input (input terminal [AI2](AIV)).

- Analog input can adjust the input signal by gain and bias. (Refer to 7-3-2 *Analog Input Adjustment Function* on page 7-38.)
- Behavior when the analog input is disconnected can be set at analog reference loss detection.

### ● Analog Reference Loss Detection

When the analog frequency reference falls to 10% or lower of the frequency reference for 400 ms, the wiring of the analog frequency reference is judged to have become disconnected, operation is continued at the frequency of the ratio set at E65 for the frequency setting value, and the analog input reference loss detection “33: REF OFF (analog input reference loss)” terminal is turned ON. When the frequency setting value returns to the value set at E65 or higher, it is judged that the disconnection has been restored, and operation is performed at the legitimate frequency setting.

Parameter No.	Function name	Data	Default data	Unit
H193	Analog Reference Loss Detection Operation Selection	0: Decelerate to stop 20% to 120% 999% 999: Cancel	0	-

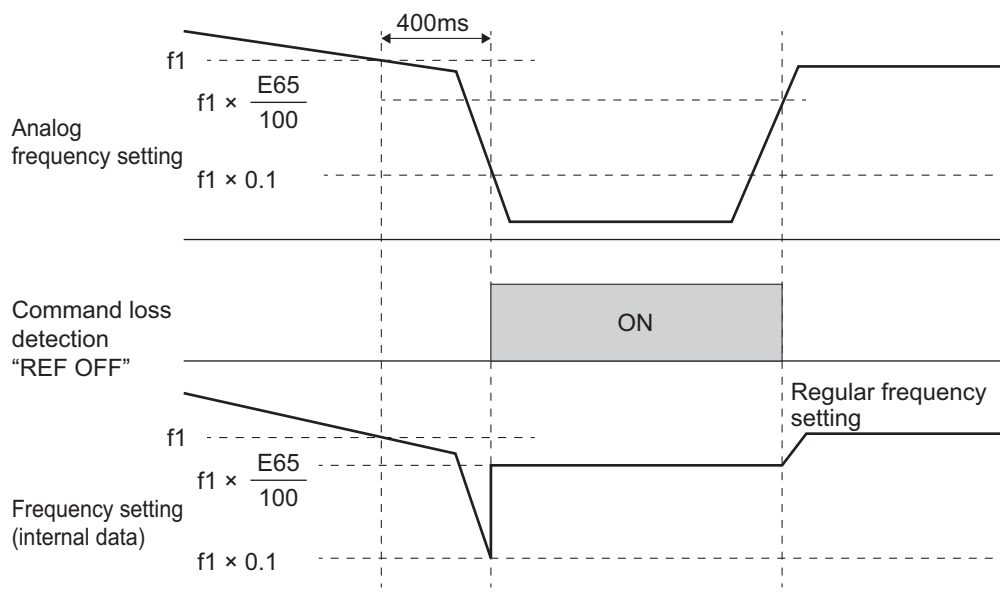

#### Additional Information

- With the frequency reference via analog input, select only linear acceleration/deceleration.

## UP/DOWN Control (Frequency Reference Selection (F01/C30) = “7”)

- Refer to 7-9-10 *UP/DOWN control* on page 7-119.



## Pattern Operation / Timed Operation Mode Selection (Frequency Reference Selection (F01/C30) = "10")

---

- Refer to *5-5-3 Pattern Operation / Timed Operation Function* on page 5-33.

## Command Based on Pulse Train Input (Frequency Reference Selection (F01/C30) = "12")

---

- Refer to *7-9-17 Pulse Train Frequency Input* on page 7-145.

## Command via Calculation Result of Frequency Calculation Function (Frequency Reference Selection (F01/C30) = "13")

---

- Refer to *7-9-8 Frequency Calculation Function* on page 7-118.

## Command Based on Communication (Frequency Reference Selection (F01/C30) = "14")

---

- Refer to *Section 8 Communications Functions* on page 8-1.

## Frequency Reference Correlation Chart

---

Set the frequency reference at 1st Frequency Reference Selection (F01)/2nd Frequency Reference Selection (C30).

Alternatively, the frequency reference can be switched via multifunction input. Below shows a chart showing the correlation between priority, related parameters, and related multifunction input terminals when the frequency reference is switched.

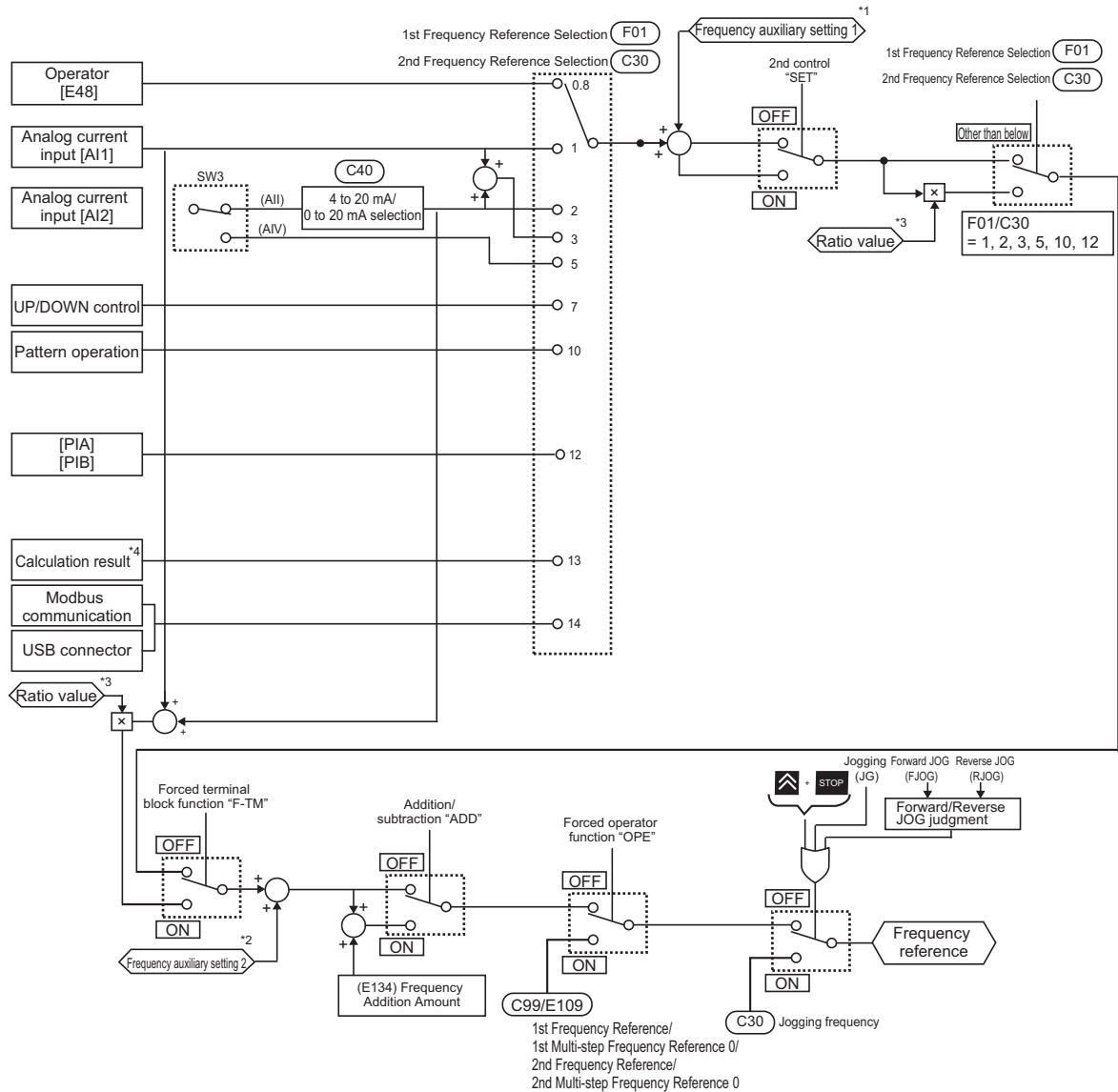

The presence/absence of the pulse train command depends on the combination of the following parameter settings.

F01	C30	E131	E132	E119	Pulse train command
Any one is 12	Ignore				Set frequency
Any one is 13	Any one is 5		45		PID feedback
Other than the above				3	Without
Other than the above					Without

- \*1. Auxiliary frequency setting 1 is set by setting 1 to Extended functions (E61/E62/E63).
- \*2. Auxiliary frequency setting 2 is set by setting 2 to Extended functions (E61/E62/E63).
- \*3. Ratio value is set by setting 6 to Extended functions (E61/E62/E63).
- \*4. For details on the result of logical operation, refer to 7-9-8 *Frequency Calculation Function* on page 7-118.

## 5-5-2 Frequency Limit

- Use this function to set the upper and lower limits of the output frequency. The set limits will be applied if the input frequency reference is beyond the upper/lower limit(s).
- Be sure to set so that the Frequency Upper Limit (F15/E117) is greater than the Frequency Lower Limit (F16/E118).
- Set the lower limit so that it does not reach or exceed Maximum Output Frequency (F03/A01).
- When 0 Hz is set to the upper limit, operation is limited to 0 Hz and disabled.

- Processing when the set frequency is less than the Frequency Lower Limit (F16/E118) can be selected at Frequency Lower Limit Operation Selection (H63).

Parameter No.	Function name	Data	Default data	Unit
F16/E117	1st Frequency Upper Limit/2nd Frequency Upper Limit*1	0.00 to 590.0	70.0	Hz
F16/E118	1st Frequency Lower Limit/2nd Frequency Lower Limit*1	0.00 to 590.0	0.0	Hz
H63	Frequency Lower Limit Operation Selection	0: Frequency Command is the Frequency Lower Limit. 1: Frequency Command is 0Hz	0	-

\*1. To enable switching to the 1st and 2nd control, allocate "12: SET (2nd control)" to either of input terminal [DI1] to [DI7].

- When "0: Frequency Command is the Frequency Lower Limit" is selected at Frequency Lower Limit Operation Selection (H63), the output frequency becomes the frequency set at Frequency Lower Limit (F16/E118) even if the frequency reference is set to less than Frequency Lower Limit (F16/E118). Even if 0 Hz is set to the frequency reference, priority is given to the lower limit. For this reason, turn the RUN command OFF to stop output.

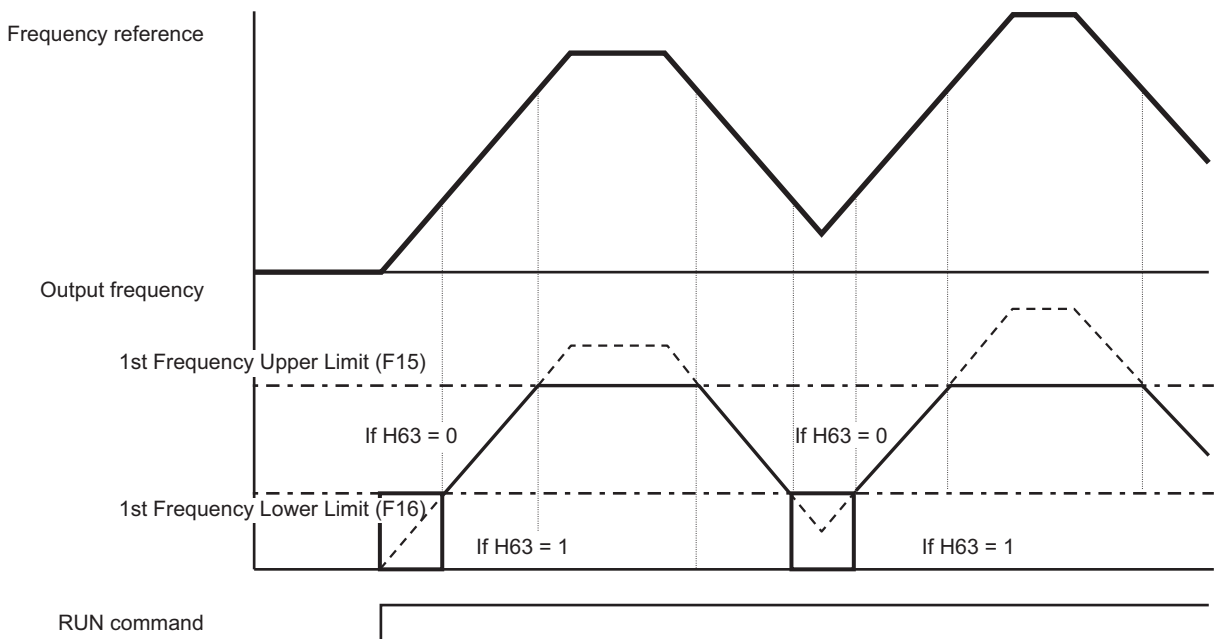

### 5-5-3 Pattern Operation / Timed Operation Function

- To perform Pattern Operation / Timed Operation, set Frequency Reference Selection (F01/C30) = "10."
- The pattern operation function operates according to seven preset patterns.
- Operation time, rotation direction, acceleration/deceleration time, and the frequency reference are set to patterns.
- Three pattern operations can be selected: one cycle operation, repetition operation and constant speed operation after 1 cycle operation,
- The status of pattern operation can be output to output terminal [DO1].

- Timed operation is performed when “3: Timed operation” is selected at Pattern Operation / Timed Operation Mode Selection (C21).

Parameter No.	Function name	Data	Default data	Unit
C21	Pattern Operation / Timed Operation Mode Selection	0: 1 cycle operation*1 1: Repetition operation 2: Constant speed operation after 1 cycle operation*2 3: Timed operation	0	-
C22 to C28	Pattern Operation Stage 1 Operation Setting to Pattern Operation Stage 7 Operation Setting	0000 to FFFF hex  Bit 15: 0 = Forward 1 = Reverse Bit 14: Fixed to 0 (Not used) Bit 13 to 12: Acceleration/Deceleration time selection 0=1st Acceleration Time 1 (F07)/1st Deceleration Time 1 (F08) 1 = 2nd Acceleration Time 1 (E10)/2nd Deceleration Time 1 (E11) 2 = 1st Acceleration Time 2 (E12)/1st Deceleration Time 2 (E13) 3= 2nd Acceleration Time 2 (E14)/2nd Deceleration Time 2 (E15)  Bit 11 to 10: Minimum unit of operation time 0 = X 0.01 1 = X 0.1 2 = X 1 3 = X 10 Bit 9 to 0: Data part of operation time When minimum unit 0 (X 0.01); 000 hex to 3E7 hex (0.00 to 9.99)  When minimum unit 1 (X 0.1); 064 hex to 3E7 hex (10.0 to 99.9) Note 1  When minimum unit 2 (X 1); 064 hex to 3E7 hex (100 to 999) Note 1  When minimum unit 3 (X 10); 064 hex to 258 hex (1000 to 6000) Note 2  Note 1) (0000 hex to 0063 hex)(03E8 hex to 03FF hex) cannot be set. Note 2) (0000 hex to 0063 hex)(0259 hex to 03FF hex) cannot be set.	0	-
C05 to C11	Multi-step Frequency Reference 1 to 15	0.00 to 590.00 Hz	0	Hz

Parameter No.	Function name	Data	Default data	Unit
E20	Output Terminal [DO1]	16: TU (transition to pattern operation stage)	0	-
E21	Function Selection	17: TO (pattern operation cycle operation completion)		
E27	Output Terminal [DO2]	18: STG1 (pattern operation stage No.1)		
	Function Selection	19: STG2 (pattern operation stage No.2)		
	Output Terminal [ROA, ROB]	20: STG4 (pattern operation stage No.4)		
	Function Selection			

- \*1. With the deceleration time after end of one cycle, a deceleration stop is performed according to the setting value of 1st Deceleration Time 1 (F08).
- \*2. With constant speed operation after end of one cycle, constant speed operation is performed according to the last set frequency in pattern operation.

## Pattern operation

- Operation is as follows when 0 to 2 is selected at Pattern Operation / Timed Operation Mode Selection (C21.)

1. Pattern Operation / Timed Operation Mode Selection (C21) = "0: 1 cycle operation (Pattern operation)"

A deceleration stop is performed after one cycle operation by the preset pattern.

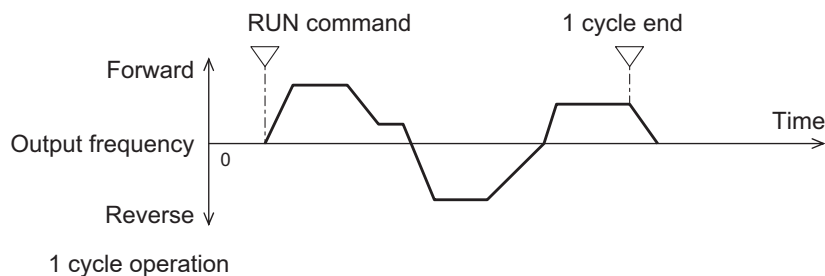

2. Pattern Operation / Timed Operation Mode Selection (C21) = "1: Repetition operation (Pattern operation)"

Operation by the preset pattern is repeated.

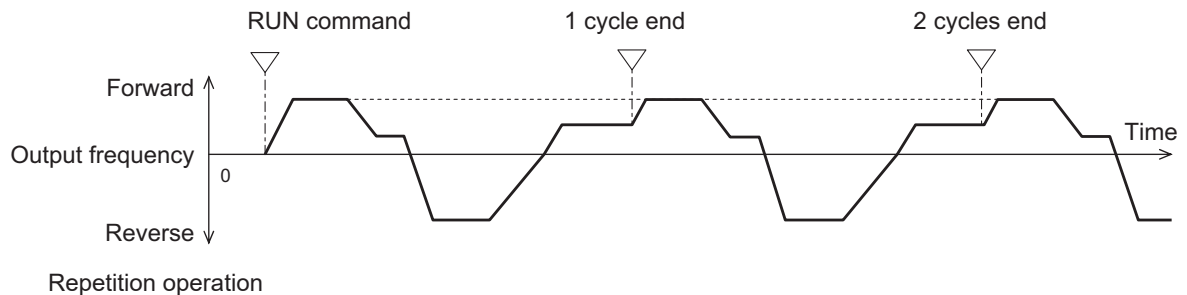

3. Pattern Operation / Timed Operation Mode Selection (C21) = "2: Constant speed operation (Pattern operation) after 1 cycle operation"

After one cycle operation by the preset pattern, constant speed operation is performed in accordance with the last set frequency of pattern operation.

To stop constant speed operation, turn the RUN command OFF.

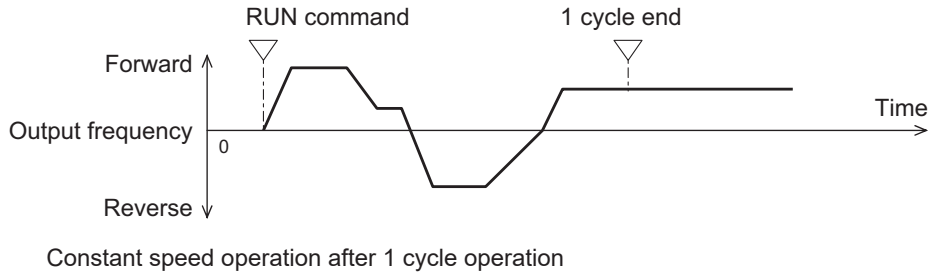



## Pattern Operation Setting

- To set the patterns in pattern operation, set the operation time, rotation direction and acceleration/deceleration time to Pattern Operation Stage 1 Operation Setting to Pattern Operation Stage 7 Operation Setting (C22 to C28). The following describes the method for setting stages in Operator and in Sysmac Studio.

### <Setting stages in Operator>

Set the operation time, rotation direction and acceleration/deceleration time of stages 1 to 7 to Pattern Operation Stage 1 Operation Setting to Pattern Operation Stage 7 Operation Setting (C22 to C28)

For operation on the Digital Operator, press the  key three times for the respective parameter and set the three types of data.

If parameter setup is exited by the  key before pressing the  key three times and setting the three types of data, the data will not be updated.

Setting	Description
First time	The operation time is set in the range 0.0 to 6000 s.
Second time	The operation direction is to FW (forward) or RV (reverse).
Third time	The acceleration/deceleration time is set in the range 1 to 4. 1: Follows F07/F08 2: Follows E10/E11 3: Follows E12/E13 4: Follows E14/E15

### <Setting stages in Sysmac Studio>

Set Pattern Operation Stage 1 Operation Setting to Pattern Operation Stage 7 Operation Setting (C22 to C28) in hexadecimal.

Example: In case of (reverse rotation, 2nd deceleration time, 10.0 s)

Rotation direction Reverse: 8000 hex

Acceleration/deceleration time 2nd acceleration/deceleration time: 1000 hex

Operation time 10.0 s = 0.1 × 100: 0400 hex + 0064 hex

Accordingly, the set value becomes 8000 hex + 1000 hex + 0400 hex + 0064 hex = 9464 hex

- Stages set with an operation time of 0.0 are disabled and are ignored.
- Each of Multi-step Frequency Reference 1 to 7 (C05 to C11) is applied to the frequency setting of stages 1 to 7.
- When “18: STG1 (pattern operation stage No.1)” to “20: STG4 (pattern operation stage No.4)” is allocated to output terminals DI1 to DI7, the stage (phase of operation) currently operating by ON/OFF of the output signal can be checked. For details, refer to the operation example figure below.

Operation pattern stage No.	Output terminal signal		
	STG1	STG2	STG4
Stage 1	ON	OFF	OFF
Stage 2	OFF	ON	OFF
Stage 3	ON	ON	OFF
Stage 4	OFF	OFF	ON
Stage 5	ON	OFF	ON
Stage 6	OFF	ON	ON
Stage 7	ON	ON	ON

- The signal can be output at completion of cycle operation when the pattern operation stage is transitioned to by allocating "16: TU (transition to pattern operation stage)" and "17: TO (pattern operation cycle operation completion)" to output terminals DI1 to DI7. For details, refer to the operation example figure below.



#### Precautions for Correct Use

When C21=0 is set and pattern operation is started by input via the FW/RV terminals turning ON, the motor stops when the final stage ends even if the FW/RV terminals stay ON. At this time, when the value of F01/C30 is changed without turning the FW/RV terminals OFF, operation is immediately started according to the set frequency after the value is changed.

#### ● Pattern operation setting examples

C21 (Pattern Operation / Timed Operation Mode Selection)	Stage No.	Operation time	Rotation direction	Acceleration/deceleration time	Operation (reference) frequency
		Set value	Set value	Set value	
0	Stage 1	60.0	F	2	C05 Multi-step Frequency Reference 1
	Stage 2	100	F	1	C06 Multi-step Frequency Reference 2
	Stage 3	65.5	r	4	C07 Multi-step Frequency Reference 3
	Stage 4	55.0	r	3	C08 Multi-step Frequency Reference 4
	Stage 5	50.0	F	2	C09 Multi-step Frequency Reference 5
	Stage 6	72.0	F	4	C10 Multi-step Frequency Reference 6
	Stage 7	35.0	F	2	C11 Multi-step Frequency Reference 7

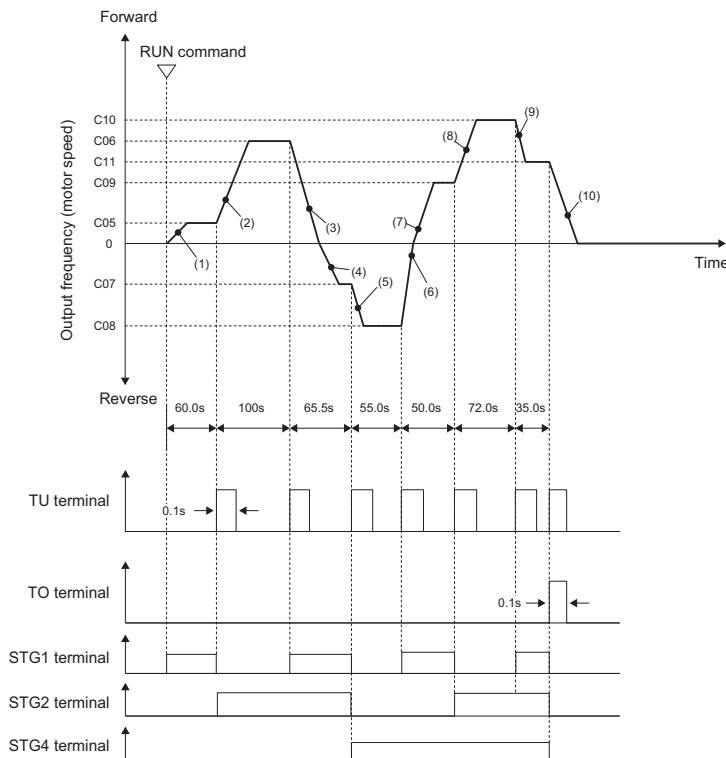

This is illustrated as follows.



Acceleration times or deceleration times set at (1) to (10)

(1)	Acceleration time: E10
(2)	Acceleration time: F07
(3)	Deceleration time: E15
(4)	Acceleration time: E14
(5)	Acceleration time: E12
(6)	Deceleration time: E11
(7)	Acceleration time: E10
(8)	Acceleration time: E14
(9)	Deceleration time: E11
(10)	Deceleration time: F08

## Timed operation

- With the timed operation function, operation is performed for a preset time and is stopped when the timer value reaches 0.
- Operation is performed by timed operation when “3: Timed operation” is selected at Pattern Operation / Timed Operation Mode Selection (C21).
- When operation is stopped during timed operation, timed operation can be stopped.
- The following shows the procedure for setting timed operation.
  1. Set “3: Timed operation” to Pattern Operation / Timed Operation Mode Selection (C21) and “13” to Operator Display Selection during Run (E43).
  2. Set the timer time (time unit: seconds) by the  /  keys while viewing the timer value on the LED monitor.
  3. When the RUN command is input and operation is started, the timer time is counted down. After the timer time elapses, the motor stops. (Timed operation is enabled also when the LED monitor displays a value other than the timer value.)



### Additional Information

When operation is performed on the FW terminal,  and LED monitor display are displayed alternately when a deceleration stop is made after timed operation. When the FW terminal is set to OFF, the display returns to the LED monitor display.



## 5-6 Acceleration/deceleration time

### 5-6-1 Acceleration/Deceleration Time Setting

- Set the motor acceleration/deceleration time.
- The set time here is the acceleration/deceleration time from 0 Hz to the maximum frequency. The actual acceleration/deceleration time varies depending on the frequency reference value.
- This parameter is for setting the time constant of the primary delay filter with respect to the output frequency during acceleration/deceleration when V/f control (F42/A14 = 0 to 3) is selected. Set this parameter when an overshoot or undershoot occurs when the frequency arrives at the target frequency or the rotation of the motor stops and this causes mechanical problems. Setting a large value stabilizes the output frequency but worsens response.

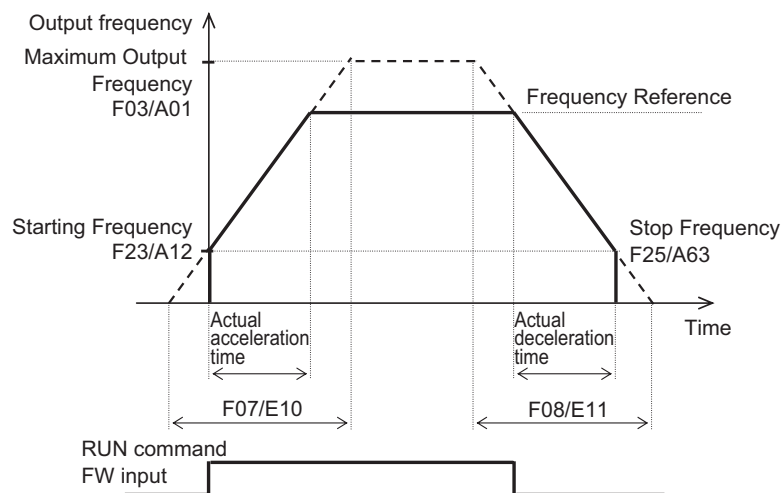

Parameter No.	Function name	Data	Default data	Unit
F07	1st Acceleration Time 1	0.00 to 6000 s	6.00	s
E10	2nd Acceleration Time 1 <sup>*1</sup>			
F08	1st Deceleration Time 1	0.00 to 6000 s	6.00	s
E11	2nd Deceleration Time 1 <sup>*1</sup>			
d86	Acc/Dec Output Frequency Filter	0.000 to 5.000 s	0.000	s
Related functions		F03, A01, E01 to E05, E98, E99		

\*1. To enable switching to the 1st and 2nd control, allocate "12: SET (2nd control)" to either of input terminal [D11] to [D17].



#### Additional Information

When a short deceleration time is set, the regenerative amount that is fed back at deceleration increases. When the regenerative amount exceeds the allowable capacity of the inverter, either the deceleration time is extended by the setting of Anti-regenerative Control Function Selection (H69), or overvoltage (OU2) is detected. To shorten the deceleration time, use the regenerative braking function. For details on the regenerative braking function, refer to 5-12 *Regenerative Braking Function* on page 5-75.

## 5-6-2 Acceleration/Deceleration Pattern

- Use this function to set the acceleration/deceleration pattern.
- Select the acceleration/deceleration pattern at Acceleration/Deceleration Pattern Selection (H07).
- These acceleration/deceleration patterns are enabled also for frequency reference input via analog input terminals.

Parameter No.	Function name	Data	Default data	Unit
H07	Acceleration/Deceleration Pattern Selection	0 to 3 0: Disable (Linear acceleration/deceleration) 1: S-curve acceleration/deceleration (Weak) 2: S-curve acceleration/deceleration (Arbitrary: According to H57 to H60) 3: Curve acceleration/deceleration	0	-
H57	S-curve Acceleration Range Frequency at Starting	0 to 100%	10	%
H58	S-curve Acceleration Range Frequency at End			
H59	S-curve Deceleration Range Frequency at Starting			
H60	S-curve Deceleration Range Frequency at End			
Related function		F03, A01		

### Pattern Selection

- Set Acceleration/Deceleration Pattern Selection (H07) according to the following table.

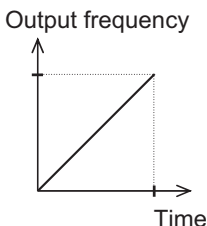
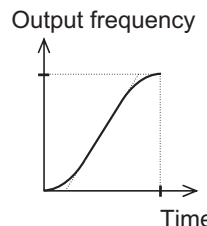
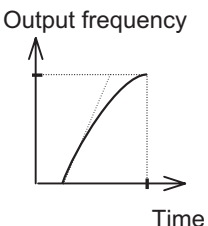
H07 (Acceleration/Deceleration Pattern Selection)	Set value			
	0	1	2	3
	Disable (Linear acceleration/deceleration)	S-curve acceleration/deceleration	S-curve acceleration/deceleration (Arbitrary)	Curve acceleration/deceleration
At acceleration				

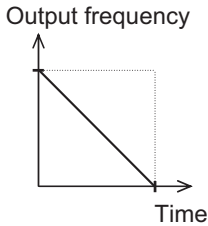
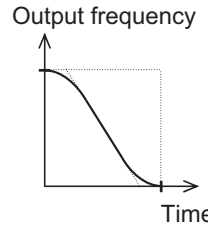
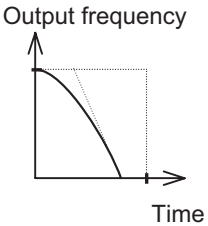
H07 (Acceleration/Deceleration Pattern Selection)	Set value			
	0	1	2	3
	Disable (Linear acceleration/deceleration)	S-curve acceleration/deceleration	S-curve acceleration/deceleration (Arbitrary)	Curve acceleration/deceleration
At deceleration				

### S-curve Acceleration/Deceleration Range

- When “2: S-curve acceleration/deceleration (Arbitrary)” is selected at Acceleration/Deceleration Pattern Selection (H07), set S-curve Acceleration Range Frequency at Starting (H57), S-curve Acceleration Range Frequency at End (H58), S-curve Deceleration Range Frequency at Start (H59) and S-curve Deceleration Range Frequency at End (H60). When “1: S-curve acceleration/deceleration” is set at Acceleration/Deceleration Pattern Selection (H07), each are fixed at 5%.
- The larger the values of S-curve Acceleration Range Frequency at Starting (H57), S-curve Acceleration Range Frequency at End (H58), S-curve Deceleration Range Frequency at Start (H59) and S-curve Deceleration Range Frequency at End (H60) are, the gentler acceleration/deceleration is performed. For this reason, the actual acceleration/deceleration time is longer than the set acceleration/deceleration time.

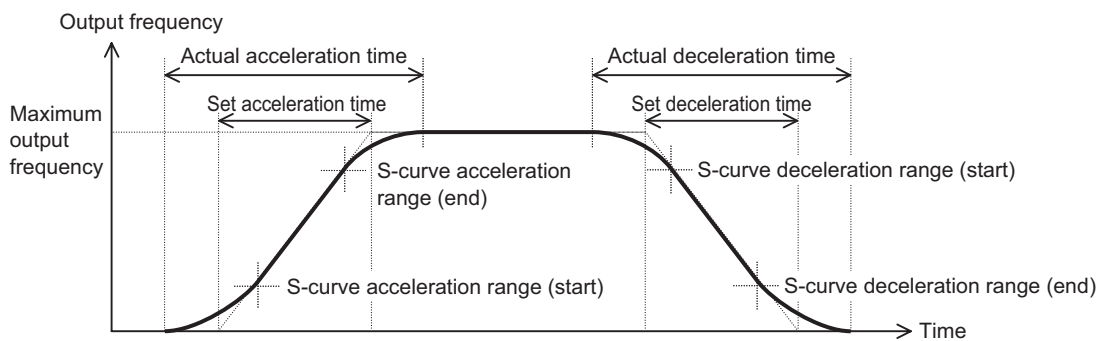

	S-curve acceleration range (start)	S-curve acceleration range (end)	S-curve deceleration range (start)	S-curve deceleration range (end)
S-curve acceleration/deceleration	5% (fixed)	5% (fixed)	5% (fixed)	5% (fixed)
S-curve acceleration/deceleration (Arbitrary)	0 to 100% S-curve Acceleration Range Frequency at Starting (H57)	0 to 100% S-curve Acceleration Range Frequency at End (H58)	0 to 100% S-curve Deceleration Range Frequency at Starting (H59)	0 to 100% S-curve Deceleration Range Frequency at End (H60)

### 5-6-3 Acceleration/Deceleration Stop Function

- This function causes the inverter stop accelerating/decelerating temporarily and start running at a constant speed at the frequency output at that time.
- There are two acceleration/deceleration stop methods as follows, which can be used in conjunction with each other.
  - When the output frequency reaches the set frequency, acceleration/deceleration stops for the set stop time.
  - Stop the acceleration/deceleration operation by entering “163: HLD (Acceleration/deceleration stop)” in Input Terminal [DI1] Function Selection to Input Terminal [DI7] Function Selection (E01 to E05, E98, E99).

Parameter No.	Function name	Data	Default data	Unit
E103	Acceleration Stop Frequency	0.00 to 590.0	0.00	Hz
E104	Acceleration Stop Time	0.0 to 60.0	0.0	s
E105	Deceleration Stop Frequency	0.00 to 590.0	0.00	Hz
E106	Deceleration Stop Time	0.0 to 60.0	0.0	s
E01 to E05, E98, E99	Input Terminal [DI1] Function Selection to Input Terminal [DI7] Function Selection	163: HLD (Acceleration/deceleration stop)	-	-

- If the HLD terminal is ON, acceleration/deceleration operation stops regardless of the stop time. Until the set stop time elapses, acceleration/deceleration stops continuously even if the HLD terminal is turned OFF during the set stop frequency.

#### Stopping when the specified frequency/stop time is reached

- Set the frequency at which acceleration operation is stopped to E103, and set the time that acceleration operation is stopped to E104. To not stop acceleration operation, set Acceleration Stop Time (E104) to 0.0.
- Set the frequency at which deceleration operation is stopped to E105, and set the time that deceleration operation is stopped to E106. To not stop deceleration operation, set Deceleration Stop Time (E106) to 0.0.

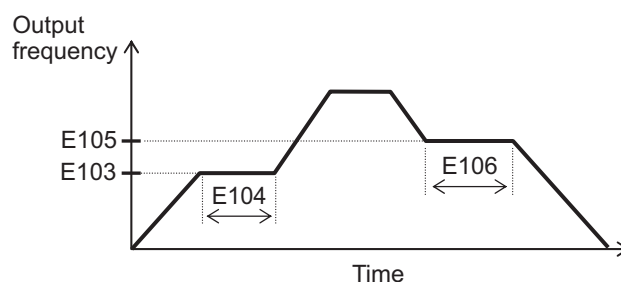

## Stopping via input to a multifunction input terminal

- When the HLD terminal is turned ON during acceleration, acceleration is stopped, and when it is turned OFF, acceleration is resumed.
- When the HLD terminal is turned ON during deceleration, deceleration is stopped, and when it is turned OFF, deceleration is resumed.

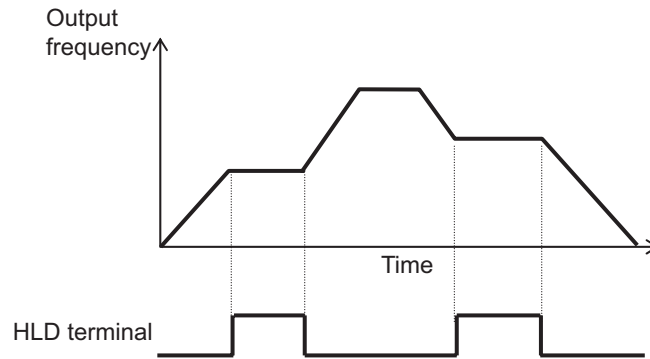

### 5-6-4 2-step Acceleration/Deceleration Function

- Use the 2-step acceleration/deceleration function to control two acceleration/deceleration time.
- The acceleration/deceleration time switching method can be selected from the following four.
  - E125/E126 = 0: Switching by 2CH terminal (Input Terminal Function Selection set to “159: 2CH (2-step acceleration/deceleration)”) (Example 1)
  - E125/E126 = 1: Switching by 2-step acceleration/deceleration (E127 to E130) (switching frequency set at E127 to E130) (Example 2)
  - E125/E126 = 2: Switching at forward/reverse switching (Example 3)
  - E125/E126 = 3: Switching by RT1, RT2 terminals (Example 4)
- To switch via an input terminal, allocate “159: 2CH (2-step acceleration/deceleration),” or “4: RT1 (2-step acceleration/deceleration),” “5: RT2 (Acceleration/deceleration Time Selection 2)” to one of Input Terminal [DI1] Function Selection to Input Terminal [DI7] Function Selection (E01 to E05, E98, E99).
- For acceleration time 2 (E12/E14) and deceleration time 2 (E13/E14), set the time from frequency 0 Hz up to the maximum frequency in the same way as acceleration time 1 (F07/E10) and deceleration time 1 (F08/E11).
- Acceleration/deceleration pattern and acceleration/deceleration operation stop also can be used.

Parameter No.	Function name	Data	Default data	Unit
F07	1st Acceleration Time 1	0.00 to 6000	6.00	s
F08	1st Deceleration Time 1			
F10	2nd Acceleration Time 1 <sup>*1</sup>			
E11	2nd Deceleration Time 1 <sup>*1</sup>			
E12	1st Acceleration Time 2			
E13	1st Deceleration Time 2			
E14	2nd Acceleration Time 2 <sup>*1</sup>			
E15	2nd Deceleration Time 2 <sup>*1</sup>			

Parameter No.	Function name	Data	Default data	Unit
E125	1st 2-step Acceleration/ Deceleration switching Condition Selection	0: Switching by 2CH terminal (159: 2-step acceleration/deceleration) 1: Switching by setting 2: Forward and reverse 3: Switching by RT1, RT2 terminals	0	-
E126	2nd 2-step Acceleration/Deceleration Switching Condition Selection*1			
E127	1st 2-step Acceleration Switching Frequency			
E128	2nd 2-step Acceleration Switching Frequency*1	0.00 to 590.0	0.00	Hz
E129	1st 2-step Deceleration Switching Frequency			
E130	2nd 2-step Deceleration Frequency*1			
d86	Acc/Dec Output Frequency Filter	0.000 to 5.000	0.000	s
Related functions		F07, E10, F08, E11, E01 to E05, E98, E99		

\*1. To enable switching to the 1st and 2nd control, allocate "12: SET (2nd control)" to either of input terminal [DI1] to [DI7].

## 2-step Acceleration/Deceleration Switching Condition Selection (E125/E126 = "0: Switching by 2CH terminal (159: 2-step Acceleration/Deceleration)" (Example 1))

- When 2CH terminal is ON, acceleration/deceleration is performed at acceleration time 2 (E12/E14) or deceleration time 2 (E13/E15). When the terminal is OFF, acceleration/deceleration is performed at acceleration time 1 (F07/E10) or deceleration time 1 (F08/E11).

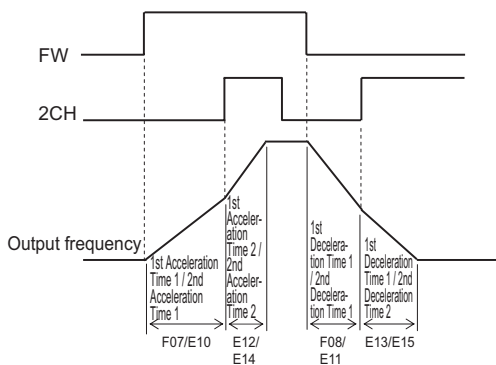

## 2-step Acceleration/Deceleration Switching Condition Selection (E125/E126 = "2: Switching only at forward/reverse switching" (Example 2))

- During forward rotation, acceleration is performed at acceleration time 1 (F07/E10) from output frequency 0 Hz up to 2-step Acceleration Switching Frequency (E127/E129). Acceleration is performed at acceleration time 2 (E12/E14) from 2-step Acceleration Switching Frequency (E127/E129) up to the maximum output frequency.
- During reverse rotation, deceleration is performed at deceleration time 1 (F08/E11) from output frequency 0 Hz up to 2-step Deceleration Switching Frequency (E129/E130). Deceleration is

performed at deceleration time 2 (E13/E15) from 2-step Deceleration Frequency (E129/E130) up to the maximum output frequency.

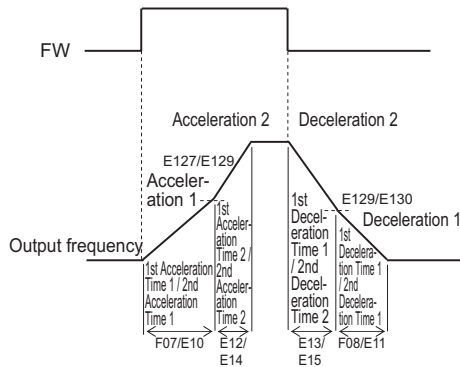

### 2-step Acceleration/Deceleration Switching Condition Selection (E125/E126 = "2: Switching at forward/reverse switching" (Example 3))

- During forward rotation, acceleration/deceleration is performed at acceleration time 1 (F07/E10) or deceleration time 1 (F08/E11). During reverse rotation, acceleration/deceleration is performed at acceleration time 2 (E12/E14) or deceleration time 2 (E13/E15).

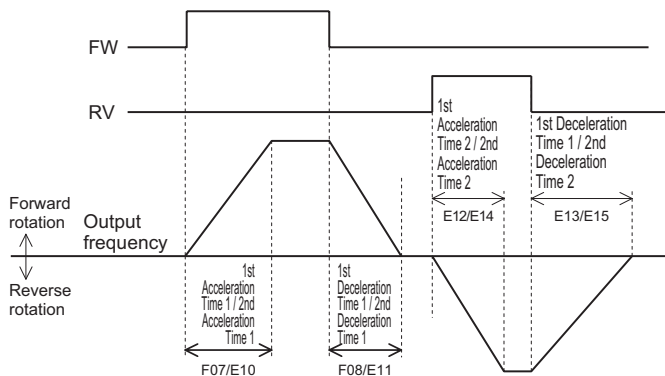

### 2-step Acceleration/Deceleration Switching Condition Selection (E125/E126 = "3: Switching by RT1 Terminal (4: 2-step Acceleration/Deceleration), RT2 Terminal (5: Acceleration/Deceleration Time Selection 2)" (Example 4))

- With RT1 terminal (4: 2-step Acceleration/Deceleration) and RT2 terminal (5: Acceleration/Deceleration Time Selection 2) combined, select the acceleration/deceleration time during which acceleration/deceleration is performed.

RT2 terminal	RT1 terminal	Selected acceleration/deceleration time
OFF	OFF	1st Acceleration Time 1 (F07), 1st Deceleration Time 1 (F08)
OFF	ON	2nd Acceleration Time 1 (E10), 2nd Deceleration Time 1 (E11)
ON	OFF	1st Acceleration Time 2 (E12), 1st Deceleration Time 2 (E13)
ON	ON	2nd Acceleration Time 2 (E14), 2nd Deceleration Time 2 (E15)

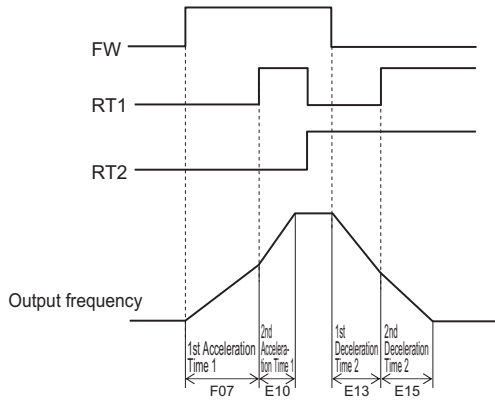



## 5-7 Stop Operation

The stop operation methods are as follows.

- Stop by RUN command

Trigger	Stop operation	Reference page
 key on the Operator	Select stop by deceleration time or free-run stop at Stop Selection (H11). The STOP key priority function can be used.	page 7-80
FW terminal/RV terminal or 3-wire operation stop		page 5-56
Operation stop via Modbus communication		page 8-87
Jogging operation stop		page 5-60



- Stop from external input terminal

Trigger	Stop operation	Reference page
Forced stop (30: STOP) terminal	Deceleration Time for Forced Stop (H56)	page 7-152
External trip (9: EXT) terminal	Free-run stop	page 7-87
Free-run stop (7: FRS) terminal	Free-run stop	page 7-60

- Stop by error occurrence

Trigger	Stop operation	Reference page
Trip by error occurrence	Free-run stop	page 9-4
Overvoltage/overcurrent occurrence	Select trip or restart at Overvoltage/Overcurrent Restart Function Selection (E139).	page 7-58
Momentary power failure	Select whether to perform a free-run by trip or perform continuous running or a restart at a momentary power failure at Power Interruption Restart Mode Selection (F14).	page 7-49

### 5-7-1 Stop Selection

- Select whether you want the motor to make a deceleration stop according to the deceleration time setting or a free-run stop, when the stop command is input via the Digital Operator or the control circuit terminal block.
- Stop Selection (E11) is enabled by a stop by the following selected at RUN Command Selection (F02). Priority can be set to the  key on the Operator.
- In position control, a deceleration stop is performed regardless of the setting of Stop Selection (H11).
- When STOP Key Priority enable (H96 = 1 or 3) is selected and “1: External signal (digital input)” or “4: RS-485 communication” is selected at RUN Command Selection (F02/E102), when the  key is pressed, stop operation in accordance with the setting of Stop Selection (H11) is performed, and the operation error (Er6: sub code 1) is displayed on the LED monitor.

Parameter No.	Function name	Data	Default data	Unit
H11	Stop Selection	0: Normal deceleration 1: Free run stop	0	-
H96	STOP Key Priority/Start Check Function	0: Disable STOP key priority, disable start check function 1: Enable STOP key priority, disable start check function 2: Disable STOP key priority, enable start check function 3: Enable STOP key priority, enable start check function	0	-
Related function		RUN Command Selection (F02/E102) Input Terminal Function Selection (E00 to E05, E98, E99) Deceleration time (F07, E10, F08, E11)		

### When Normal Deceleration Stop Is Selected (Stop Selection (H11) = “0”)

- Deceleration stop according to the selected deceleration hold time. For details, refer to *5-6-1 Acceleration/Deceleration Time Setting* on page 5-39.

### When Free Run Stop Is Selected (Stop Selection (H11) = “1”)

- By the free run stop function, power to the motor is cut off to stop the motor.
- To use external braking, select free-run stop. Using external braking midway during a deceleration stop may cause an overload or overcurrent.
- If operation is started again during free run operation, the inverter will restart according to Free Run Stop Restart Operation Selection (H441).

## 5-8 Reset

### 5-8-1 Reset Function

- Use the reset function to reset the trip status (output shutoff status caused by occurrence of error) of the inverter.
- The reset function is executed by the  key on the Operator, input terminal “8: RS (Reset)” terminal, Operation command (S06 bit 15:RST) via Modbus communication or the Alarm Reset Command (S14).
- When a reset is performed with the RUN command ON, the inverter may abruptly start depending on the setting of the STOP Key Priority/Start Check Function (H96). When performing a reset operation, ensure that the RUN command is OFF. For details, refer to *Start Check Function (When (H96) = “2,” “4”)* on page 7-81.

Parameter No.	Function name	Data	Default data	Unit
E01 to E05, E98, E99	Input Terminal [D11] Function Selection to Input Terminal [DI7] Function Selection	8: RS (Reset)	-	-
S14	Alarm Reset Command	0: Disable 1: Alarm reset	0	-
S06	Operation command	bit 15: RST	0	-
Related function		Output Terminal [DO1] Function Selection (E20), Output Terminal [DO2] Function Selection (E21), Output Terminal [ROA, ROB] Function Selection (E27) = “99: AL (Alarm signal)”		

### Reset by Operator

Reset alarms and cancel errors by pressing the  key on the Operator.

### Reset from Terminal

When the state of the RS (reset) terminal is changed from OFF to ON, the alarm is reset and AL (alarm output) output allocated to the multifunction output terminal is set to OFF. When it is next changed from ON to OFF, the alarm display is erased and the error state is cleared. Ensure at least 10 ms as the time for turning the RS (reset) terminal ON. During normal operation, keep the terminal set to OFF.

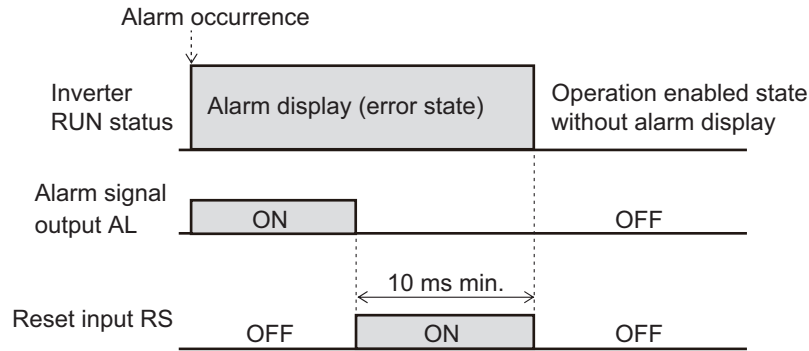

## Reset via Modbus Communication

The alarm can be reset by one of the following operations via Modbus communication.

- Set 1 to Alarm Reset Command (S14). (After a reset, this command automatically returns to 0.)
- The state of bit 15 of Operation command (S06) is changed from 0 to 1, then returns to 0. (It does not automatically return to 0.)



### Additional Information

Be sure to confirm that the RUN command is turned OFF before resetting the alarm because the machine may abruptly start depending on the setting of STOP Key Priority/Start Check Function (H96).

## 5-9 Multi-function Input

### 5-9-1 Input Terminal Functions

Functions can be operated via input terminals by allocating the functions to input terminals [DI1] to [DI7]. This section describes primary functions. For details on other functions, refer to *7-2 Multifunction Input/Output Functions List* on page 7-26.

- Set selection of functions to Input Terminal [DI1] Function Selection to Input Terminal [DI7] Function Selection (E01 to E05, E98, E99).

Parameter No.	Function name	Data	Default data	Unit
E01 to E05, E98, E99	Input Terminal [DI1] Function Selection to Input Terminal [DI7] Function Selection	Refer to the table below or <i>7-2 Multifunction Input/Output Functions List</i> on page 7-26.	-	-
H324 to H330	Input Terminal [DI1] Response Time to Input Terminal [DI7] Response Time	1 to 400 (ms)	1	ms

- By setting data in which 1000 is added to the set data, it is possible to switch from an NO contact input to an NC contact input. However, as standard, input is an NC contact, and can be changed to an NO contact by setting data in which 1000 is added. (Refer to *7-2-1 Multifunction Input Selection* on page 7-26.)

Example 1) SET terminal (2nd control)

To use the function for an NO contact, set 12. To use the function for an NC contact, set 1012.

Example 2) STP terminal (3-wire stopping: NC contact)

To use the function for an NC contact, set 6. To use the function for an NO contact, set 1006.

- If the same function is allocated to the multifunction input terminals, and if any one of the multifunction input terminals to which the function is allocated, except for the exceptions below, turns ON, the function is handled as ON. If all terminals to which “98: FW (forward rotation)” and “99: RV (reverse rotation)” is allocated are ON, the function is handled as ON.
- Set the response time for each multifunction input terminal DI1 to DI7 independently. This function is effective for removing noise caused by chattering, etc. Inputs are set when the status matches twice after checking the statuses of the input terminals at each individual set response time. For example, when 400 ms is set, up to 800 ms is required until an input is set.

Fig. 1: Example of response time matching twice and recognition of inverter ON

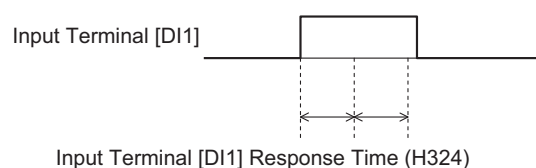
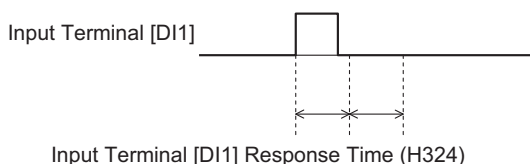

Fig. 2: Example of response time matching less than twice and non-recognition of inverter ON



Parameter No.	Set data	Function name	Reference item	Reference page
E01 to E05, E98, E99	6	SET (2nd control)	2nd control	page 5-55
	98	FW (forward rotation)*1	Forward run command	
	99	RV (reverse rotation)*1	Reverse run command	
	6	STP (3-wire stopping: NC contact)	3-wire input function	page 5-56
	97	F/R (3-wire forward/reverse rotation)		
	0	CF1 (Multi-step speed setting binary 1)	Multi-step speed operation function	page 5-57
	1	CF2 (Multi-step speed setting binary 2)		
	2	CF3 (Multi-step speed setting binary 3)		
	3	CF4 (Multi-step speed setting binary 4)		
	173	SF1 (Multi-step speed setting bit 1)		
	174	SF2 (Multi-step speed setting bit 2)		
	175	SF3 (Multi-step speed setting bit 3)		
	176	SF4 (Multi-step speed setting bit 4)		
	177	SF5 (Multi-step speed setting bit 5)		
	178	SF6 (Multi-step speed setting bit 6)		
	179	SF7 (Multi-step speed setting bit 7)		
	10	JG (Jogging)	Jogging	page 5-60
	159	2CH (2-step acceleration/deceleration)	2-step acceleration/deceleration	page 5-66
	8	RS (Reset)	Reset	page 5-66

\*1. "98: FW (forward rotation)" and "99: RV (reverse rotation)" can be allocated to only Input Terminal [DI6] Function Selection (E98) or Input Terminal [DI7] Function Selection (E99). When one function has been allocated to two terminals, the state is considered to be ON by both terminals turning ON.

## 2nd Control Function (SET)

On the M1 series, two controls are held in two parameters. There are three types of parameters: shared parameters, parameters for 1st control and parameters for 2nd control. Parameters for 1st control and parameters for 2nd control are switched for to use.

- To enable switching to the 1st and 2nd control, allocate "12: SET (2nd control)" to either of input terminal [DI1] to [DI7]. (OFF: 1st control, ON: 2nd control)
- The status of the selected control can be checked via external output terminals by allocating "49: SETM (2nd control under selection)" to Output Terminal [DO1] Function Selection (E20), Output

Terminal [DO2] Function Selection (E21) and Output Terminal [ROA, ROB] Function Selection (E27). When the SET terminal is turned ON, 2nd control is selected, and 2nd control under selection (49: SETM) turns ON.

Parameter No.	Function name	Data	Default data	Unit
E01 to E05, E98, E99	Input Terminal [DI1] Function Selection to Input Terminal [DI7] Function Selection	12: SET (2nd control selected)	-	-
Related function		Sets "49: SETM (2nd control under selection)" to Output Terminal [DO1] Function Selection (E20), Output Terminal [DO2] Function Selection (E21) and Output Terminal [ROA, ROB] Function Selection (E27).		

- 1st control and 2nd control cannot be switched when operation is stopped. During operation, the SET terminal does not operate even if it is turned ON.

The functions that can be switched by the SET terminal are as shown below.

Parameter No.		Parameter name
1st control	2nd control	
F042	A014	Drive control selection
F037	A013	V/f characteristics selection
F002	E102	RUN command selection
F001	C030	Frequency Reference Selection
C099	E109	Frequency Reference/Multi-step Frequency Reference 0
F003	A001	Maximum output frequency
F004	A002	Base Frequency
F005	A003	Rated Voltage at Base Frequency
F006	A004	Rated Voltage at Maximum Output Frequency
F007	E010	Acceleration time 1
F008	E011	Deceleration time 1
E012	E014	Acceleration time 2
E013	E015	Deceleration time 2
E125	E128	2-step Acceleration/Deceleration Switching Condition Selection
E127	E126	2-step Acceleration Switching Frequency
E129	E130	2-step Deceleration Frequency
F010	A006	Motor Electronic Thermal Characteristic Selection
F011	A007	Motor Electronic Thermal Level
F012	A008	Motor Electronic Thermal Time Constant
F015	E117	Frequency Upper Limit
F016	E118	Frequency Lower Limit
F020	A009	DC Injection Braking Start Frequency
F021	A010	DC Injection Braking Level
F022	A011	DC Injection Braking Time
F023	A012	Starting frequency
F024	A062	Starting Frequency Holding Time
F025	A063	Stop Frequency
F038	A064	Stop Frequency Detection Method Selection
F039	A065	Stop Frequency Holding Time

Parameter No.		Parameter name
1st control	2nd control	
H068	A040	Slip Compensation Operating Conditions Selection
H080	A041	Output current fluctuation damping gain for motor
F043	E146	Overload Protect Function Selection
F044	E147	Overload Protect Level
E037	E056	Overload Early Warning Detection Level
E038	E055	Overload Early Warning Detection Timer
E039	A061	Display Coefficient 1 for Transport Time / Auxiliary Display Coefficient 1 for Speed Monitor
E050	A060	Display coefficient for speed monitor
E112	E113	Torque Boost Function Selection
F009	A005	Manual Torque Boost Voltage
E122	E123	AVR Function Selection
C053	C054	Input Terminal [AI1, AI2] Normal/Inverse Operation for Frequency Command
P001	A015	Number of motor poles
P002	A016	Motor capacity
P003	A017	Motor Rated Current
P004	A018	Auto Tuning Function Selection
P005	A019	Online Tuning Function Selection
P006	A020	Motor Armature Resistance
P007	A021	Motor Parameter %R1
P008	A022	Motor Parameter %X
P053	A053	Motor %X Correction Factor
P009	A023	Slip Compensation Gain for Driving
P010	A024	Slip Compensation Response Time
P011	A025	Slip Compensation Gain for Braking
P012	A026	Rated Slip Frequency
P013	A027	Iron Loss Factor 1
P016	A030	Magnetic Saturation Factor 1
P017	A031	Magnetic Saturation Factor 2
P018	A032	Magnetic Saturation Factor 3
P019	A033	Magnetic Saturation Factor 4
P020	A034	Magnetic Saturation Factor 5
P055	A055	Torque Current for Vector Control
P056	A056	Induced Voltage Factor for Vector Control

- The following parameters are enabled only when 1st control is selected. When 2nd control is selected, this control operates by setting the following parameters.

Parameter No.	Parameter name
F018	Input Terminal [AI1, AI2] Bias for 1st Frequency Command
C050	Input Terminal [AI1, AI2] Bias Analog Input for 1st Frequency Command
H195	DC Injection Braking Startup Time
H078	1st Motor Maintenance Interval
H079	1st Preset Startup Count for Motor Maintenance
M081	1st Remaining Time before the Next Motor Maintenance
M085	1st Remaining Startup Times before the Next Motor Maintenance



Parameter No.	Parameter name
P030	1st PM Motor Starting Method
P060	1st PM Motor Armature Resistance
P061	1st PM Motor d-axis Inductance
P062	1st PM Motor q-axis Inductance
P063	1st PM Motor Induced Voltage Ke
P064	1st PM Motor Iron Loss
P065	1st PM Motor d-axis Inductance Magnetic Saturation Correction
P074	1st PM Motor Reference Current at Starting
P085	1st PM Motor Flux Limitation Value
P087	1st PM Motor Reference Current for Magnetic Pole Detection
P090	1st PM Motor Overcurrent Protection Level
P095	1st PM Motor Magnetic Pole position Offset
d080	1st PM Motor Magnetic Pole Position Pull-in Frequency

## Forward RUN Command (FW) and Reverse RUN Command (RV)

- To input the forward RUN and reverse RUN commands via the control circuit terminals, allocate “98: FW” and “99: RV” to Input Terminal [DI6] Function Selection (E98) and Input Terminal [DI7] Function Selection (E99). FW (forward rotation) and RV (reverse rotation) can be set to only Input Terminal [DI6] Function Selection (E98) and Input Terminal [DI7] Function Selection (E99).
- Set “1: External signal (digital input)” to 1st RUN Command Selection (F02) and 2nd RUN Command Selection (E102).
- If all assigned terminals to which the same RUN command (FW or RV) is assigned to input terminals [DI6] and [DI7] are ON, the function is handled as ON.

Parameter No.	Function name	Data	Default data	Unit
F02/E102	1st RUN Command Selection/2nd RUN Command Selection*1	1: External signal (digital input)	2	-
E01 to E05, E98, E99	Input Terminal [DI1] Function Selection to Input Terminal [DI7] Function Selection	98: FW (forward rotation) 99: RV (reverse rotation)	-	-

\*1. To enable switching to the 1st and 2nd control, allocate “12: SET (2nd control)” to either of input terminal [DI1] to [DI7].

- When both FW and RV turn ON, operation is the same as when they are both OFF.

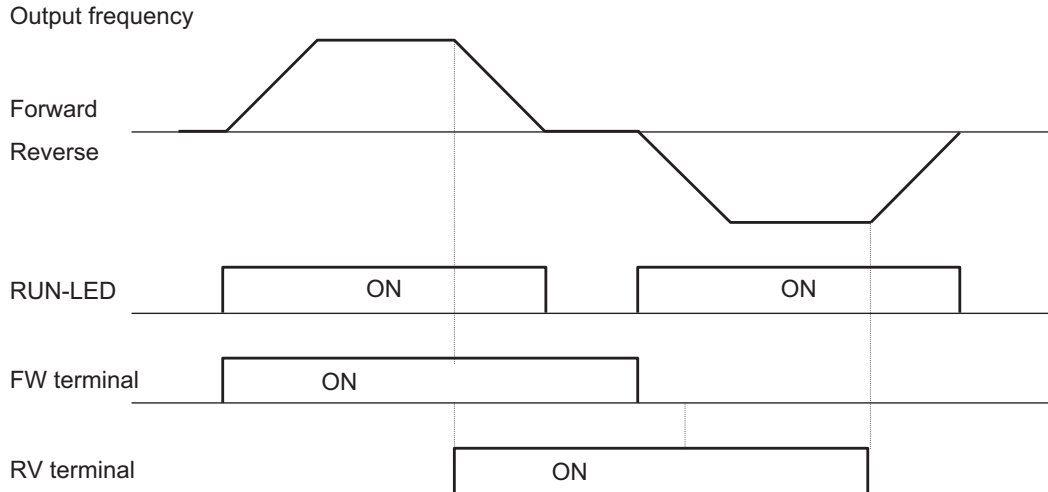

### 3-wire Input Function (FW, STP, F/R)

- To select 3-wire input, allocate the three parameters “98: FW (forward rotation),” “6: STP (3-wire stopping)” and “97: F/R (3-wire forward/reverse rotation)” to Input Terminal [DI1] Function Selection to Input Terminal [DI7] Function Selection (E01 to E05, E98, E99).
- Set “1: External signal (digital input)” to 1st RUN Command Selection (F02) and 2nd RUN Command Selection (E102).

Parameter No.	Function name	Data	Default data	Unit
F02/E102	1st RUN Command Selection/2nd RUN Command Selection*1	1: External signal (digital input)	2	-
E01 to E05, E98, E99	Input Terminal [DI1] Function Selection to Input Terminal [DI7] Function Selection	98: FW (forward rotation)*2 6: STP (3-wire stopping: NC contact) 97: F/R (3-wire forward/reverse rotation)	-	-

\*1. To enable switching to the 1st and 2nd control, allocate “12: SET (2nd control)” to either of input terminal [DI1] to [DI7].

\*2. FW (forward rotation) can be allocated to only one of E98 and E99. Also, 3-wire operation cannot be started up by “99: RV (reverse rotation).”

Data	Symbol	Function name	Status	Description
98	FW	Forward rotation (3-wire starting up)	ON	Start via automatic reset contact → 3-wire operation started by rising edge
			OFF	Independent of motor operation
6	STP	3-wire stopping: NC contact	ON	Motor operation enabled
			OFF	Stop via automatic reset contact → 3-wire operation stopped by falling edge
97	F/R	3-wire forward/reverse	ON	Reverse
			OFF	Forward

- To reliably ascertain ON/OFF, continue ON or OFF for the time twice the set value of Input Terminal Response Time (H324 to H330). When Input Terminal Response Time is the default value, continue for 2 ms.

- When the STP terminal signal is disconnected, the input signal turns OFF and the status changes to the stop status. Even if the FW terminal is turned ON in this state, the output frequency is not output.
- The operation timing is as follows.

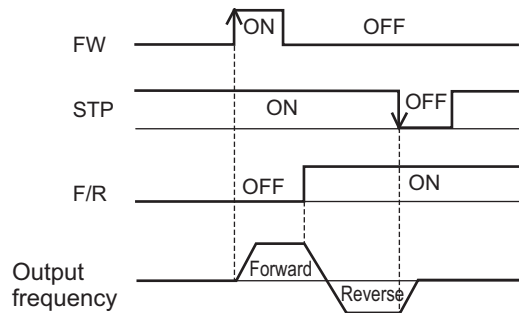

## Multi-step Frequency Reference

- Use this function to switch the frequency reference set to 16 frequencies or frequency reference set to 8 frequencies based on the combination of selected input terminals.

Parameter No.	Function name	Data	Default data	Unit
F01/C30	1st Frequency Reference Selection/2nd Frequency Reference Selection* <sup>1</sup>	0: Operator (▲ / ▼ keys) (output frequency not inherited) (disabled on EtherCAT type) 1: Analog Voltage Input (Input Terminal[A11]) 2: Analog Current Input (Input Terminal[A12](AI1)) 3: Analog Voltage Input (Input Terminal[A11]) + Analog Current Input (Input Terminal[A12](AI1)) 5: Analog Voltage Input (Input Terminal[A12](AIV)) 7: UP/DOWN control 8: Operator (▲ / ▼ keys) (output frequency inherited) 10: Pattern operation 12: Pulse train input 13: Calculation result 14: RS-485 communication	0	-
E107	Multi-step Frequency Selection	0: Binary (16-step selection with 4 terminals) 1: Bit (8-step selection with 7 terminals)	0	-
C99 E109	1st Frequency Reference/1st Multi-step Frequency Reference 0 2nd Frequency Reference/2nd Multi-step Frequency Reference 0* <sup>1</sup>	0.00 to 590.0	0.00	Hz
C05 to C19	Multi-step Frequency Reference 1 to 15	0.00 to 590.0	0.00	Hz

Parameter No.	Function name	Data	Default data	Unit
E01 to E05, E98, E99	Input Terminal [DI1] Function Selection to Input Terminal [DI7] Function Selection	(Binary operation) 0 to 3: CF1 to 4 (Multi-step frequency reference setting binary 1 to 4) (Bit operation) 173 to 179: SF1 to 7 (Multi-step frequency reference setting bits 1 to 7)	-	-

\*1. To enable switching to the 1st and 2nd control, allocate "12: SET (2nd control)" to either of input terminal [DI1] to [DI7].

- Select the setting method for 1st Frequency Reference/1st Multi-step Frequency Reference 0 (C99) or 2nd Frequency Reference/2nd Multi-step Frequency Reference 0 (E109) at 1st Frequency Reference Selection (F01) and 2nd Frequency Reference Selection (C30).
- For the set frequency, Multi-step Frequency Reference 1 to 15 are common in 1st control and 2nd control.
- Multi-step Frequency Reference 0 can be set to 1st Frequency Reference/1st Multi-step Frequency Reference 0 (C99) and 2nd Frequency Reference/2nd Multi-step Frequency Reference 0 (E109) for each of 1st and 2nd control. Multi-step Frequency Reference 1 to 15 (in bit operation, 1 to 7) are common in 1st control and 2nd control.
- To switch between Bit (8-step selection with 7 terminals) and Binary (16-step selection with 4 terminals), select "0: Binary (16-step selection with 4 terminals)" or "1: Bit (8-step selection with 7 terminals)" at Multi-step Frequency Selection (E107).
- To switch the frequency reference, allocate "173 to 179: SF1 to 7 (Multi-step frequency reference setting bits 1 to 7)" to Input Terminal [DI1] Function Selection to Input Terminal [DI7] Function Selection (E01 to E05, E98, E99) in the case of "binary (16-step selection with 4 terminals)." In the case of "8-step selection with 7 terminals," select "0 to 3: CF1 to 4 (Multi-step frequency reference setting binary 1 to 4)."
- The rotation direction becomes the direction specified by the RUN command.
- With switching of frequency selection in multi-step function, an unintended frequency reference is sometimes selected depending on the deviation of timing of input terminals [DI1] to [DI7].

### ● Binary Operation

Setting "0: CF1" to "3: CF4" to Input Terminal [DI1] Function Selection to Input Terminal [DI7] Function Selection (E01 to E05, E98, E99) enables selection of multi-step speeds 0 to 15.

- Use the Multi-step Frequency Reference 1 to 15 (C05 to C19) to set the frequency reference for the multi-step speed 1 to 15.
- Multi-step Frequency Reference 0 is selected when CF1 to CF4 are all OFF.
- Multi-step Frequency Reference 0 can be set to 1st Frequency Reference/1st Multi-step Frequency Reference 0 (C99) and 2nd Frequency Reference/2nd Multi-step Frequency Reference 0 (E109) for each of 1st and 2nd control.

Multi-step speed	CF4	CF3	CF2	CF1
0th	OFF	OFF	OFF	OFF
1st			ON	
2nd			OFF	
3rd			ON	
4th			OFF	
5th			ON	
6th			OFF	
7th	ON			
8th	ON	OFF	OFF	OFF
9th			ON	
10th			OFF	
11th			ON	
12th			OFF	
13th			ON	
14th			OFF	
15th	ON			

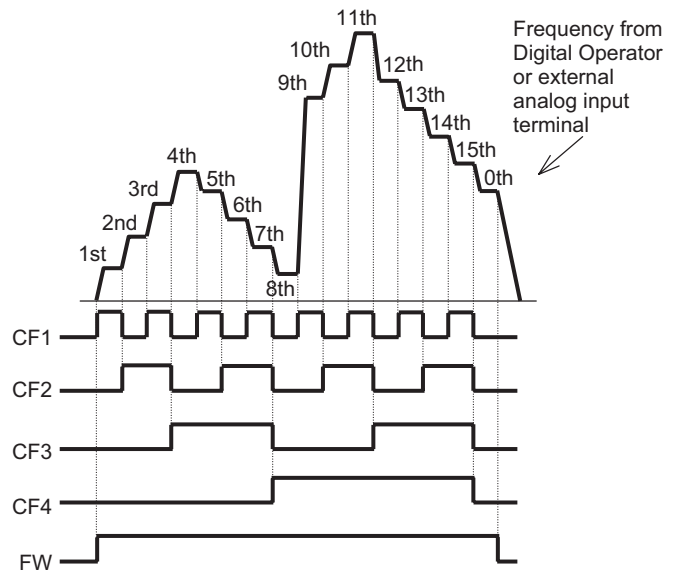

### ● Bit Operation

- Multi-step frequency references 0 to 7 can be selected by input terminals when “173: SF1” to “179: SF7” are set to Input Terminal [DI1] Function Selection to Input Terminal [DI7] Function Selection (E01 to E05, E98, E99).
- Set the frequency reference of SF1 to SF7 to Multi-step Frequency Reference 1 to 7 (C05 to C11).
- Multi-step Frequency Reference 0 is selected when SF1 to SF7 are all OFF.
- When multiple terminals are turned ON simultaneously, priority is given to the terminal with the smallest number among SF1 to SF7. (“Disabled” in the following table indicates that speed is selected regardless of the ON/OFF status.)
- Select multi-step frequency reference 0 at 1st Frequency Reference Selection (F01)/2nd Frequency Reference Selection (C30). The selected frequency reference is set to 1st Frequency Reference/1st Multi-step Frequency Reference 0 (C99) and 2nd Frequency Reference/2nd Multi-step Frequency Reference 0 (E109).

Multi-step speed	SF7	SF6	SF5	SF4	SF3	SF2	SF1
0th	OFF	OFF	OFF	OFF	OFF	OFF	OFF
1st	Disabled	Disabled	Disabled	Disabled	Disabled	Disabled	ON
2nd	Disabled	Disabled	Disabled	Disabled	Disabled	ON	OFF
3rd	Disabled	Disabled	Disabled	Disabled	ON	OFF	OFF
4th	Disabled	Disabled	Disabled	ON	OFF	OFF	OFF
5th	Disabled	Disabled	ON	OFF	OFF	OFF	OFF
6th	Disabled	ON	OFF	OFF	OFF	OFF	OFF
7th	ON	OFF	OFF	OFF	OFF	OFF	OFF

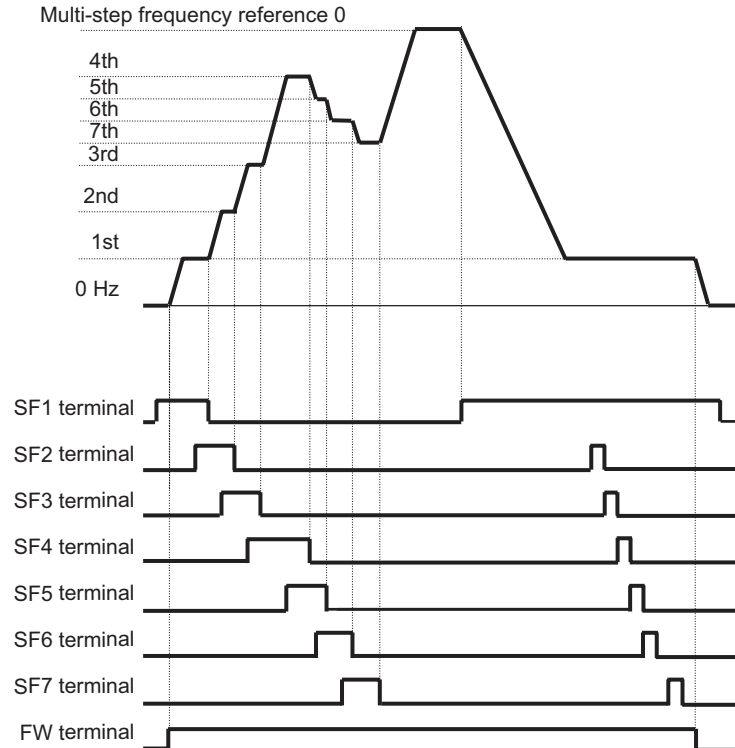

- A smaller number is sometimes selected for the frequency reference depending on the timing of switching.

## Jogging (JG)

The jogging function operates according to the jogging terminal (10: JG) and RUN command (FW or RV terminal), or forward rotation jogging terminal (94: FJOG) and reverse rotation jogging terminal (95: RJOG). The jogging function can also be enabled from the Operator.

- Jogging terminal (10: JG) and RUN command (FW or RV terminal)
- Forward rotation jogging terminal (94: FJOG) and reverse rotation jogging terminal (95: RJOG)
- Jogging function startup from Operator
- Jogging execution via communication
- Jogging frequency (C20), acceleration time (H54) and deceleration time (H55) of jogging operation can be set. Select jogging operation at start and stop of jogging at Jogging Operation Selection (E111).
- During position control, jogging operation is disabled.
- Speed control during jogging operation can be adjusted by filter, gain, etc.

Parameter No.	Function name	Data	Default data	Unit
E01 to E05, E98, E99	Input Terminal [DI1] Function Selection to Input Terminal [DI7] Function Selection	10: JG (Jogging) 94: Forward rotation jogging 95: Reverse rotation jogging	-	-







Parameter No.	Function name	Data	Default data	Unit
E111	Jogging Operation Selection	0: Free run stop on jogging stop, disabled in operation 1: Deceleration stop on jogging stop, disabled in operation 2: DC injection braking on jogging stop* <sup>1</sup> , disabled in operation 3: Free run stop on jogging stop, enabled in operation 4: Deceleration stop on jogging stop, enabled in operation 5: DC injection braking on jogging stop* <sup>1</sup> , enabled in operation	4	-
C20	Jogging frequency	0.00 to 590.00	0.00	Hz
H54	Jogging Acceleration Time	0.00 to 6000	6.00	s
H55	Jogging Deceleration Time	0.00 to 6000	6.00	s
d99	Extension Function 1	0000 to FFFF hex  Bit 3: Jogging Enable via communications Use of other bits is prohibited	0008 hex	-
d09	Speed Control Jogging Speed Command Filter	0.000 to 5.000	0.02	s
d10	Speed Control Jogging Speed Detection Filter	0.000 to 0.100	0.005	s
d11	Speed Control Jogging P Proportional Gain	0.1 to 200.0	10.0	-
d12	Speed Control Jogging I Integral Time	0.001 to 9.999 999: Disable	0.1	s
H147	Speed Control Jogging Feed Forward Gain	0.00 to 99.99	0.00	s
d13	Speed Control Jogging Output Filter	0.000 to 0.100	0.002	s
Related function		DC Injection Braking Selection (E114)		

\*1. When the Jogging Operation Selection (E111) setting is “2: DC injection braking on jogging stop, disabled in operation” or “5: DC injection braking on jogging stop, enabled in operation,” DC Injection Braking Selection (E114) must be set. Refer to 7-5-1 DC Injection Braking (DB) on page 7-63.

### ● Switching by JG terminal

- When “10: JG: (Jogging)” is set to Input Terminal [DI1] Function Selection to Input Terminal [DI7] Function Selection (E01 to E05, E98, E99), the jogging function can be switched to by the input terminals. Jogging is executed by turning the JG signal ON and then turning the FW and RV signals ON.
- Set the jogging operation stop method and whether to enable or disable the jogging function during operation at Jogging Operation Selection (E111).
- For 100 ms after the RUN command turns ON, jogging operation can be switched to by the JG (Jogging) terminal regardless of the setting of Jogging Operation Selection (E111).
- Set the frequency for jogging operation at Jogging Frequency (C20).
- Set the acceleration time and deceleration time during jogging operation at Jogging Acceleration Time (H54) and Jogging Deceleration Time (H55).

● Jogging function via Operator and RUN command

	Operation	Display on Operator
Step 1	<ul style="list-style-type: none"> <li>While the operation mode is set to the RUN mode (refer to 3-1-2 Key Operation Method on page 3-3), if the  key +  key on the Operator are pressed simultaneously during a stop, jogging operation is performed.</li> </ul>	<p>The jogging frequency is displayed on the LED monitor for approximately one second, and the screen returns to the jog display.</p> <div style="border: 1px solid black; padding: 5px; text-align: center; width: fit-content; margin: 0 auto;">  </div>
Step 2	<ul style="list-style-type: none"> <li>While the  key on the touch panel is held down, jogging operation is performed, and when the  key is released, a deceleration stop is performed.</li> </ul>	
Step 3	<ul style="list-style-type: none"> <li>If the  key +  key on the Operator are pressed during jogging operation, the jogging operation enabled state is canceled.</li> </ul>	

● Disabled in operation (when Jogging Operation Selection (E111) = “0,” “1,” “2”)

- Turn the JG terminal ON and then turn the FW or RV terminal ON.
- During operation (FW terminal is ON, RV terminal is ON), the jogging function is disabled. Note, however, that the function is enabled within 100 ms of starting operation. During operation, the jogging operation is enabled, and jogging operation is started.

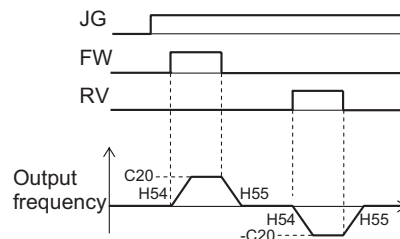

- Jogging operation is not performed if the JG signal turns ON after the FW signal turns ON first and 100 ms or more elapses. To perform jogging operation, turn the JG terminal ON and then turn the FW or RV terminal ON.

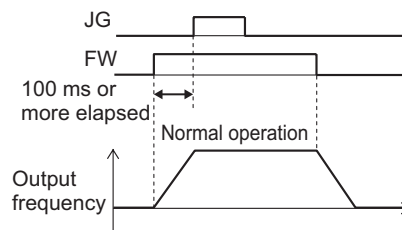

Fig.: Operation of setting when disabled while inverter is running



● **Enabled in operation (when Jogging Operation Selection (E111) = “3,” “4,” “5”)**

- Jogging is performed even if the FW signal turns ON first.

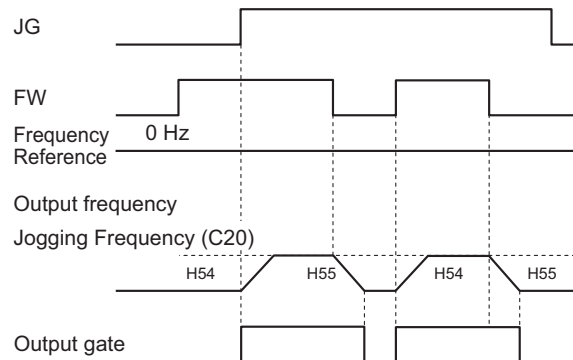

Fig.: Jogging operation switching while inverter is running

However, if the JG signal turns OFF first, the motor comes to a free-run state.

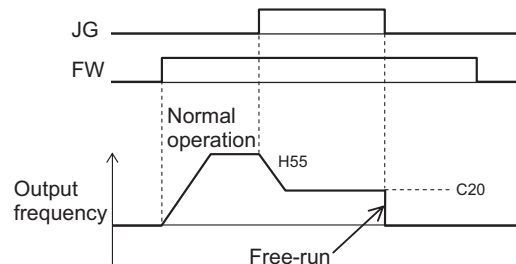

Fig.: Operation when jogging is canceled

If the JG signal is turned ON again with the motor in a free-run state (JG signal OFF and FW signal ON), jogging operation is started again.

If the FW signal is turned OFF with the motor in a free-run state (JG signal OFF and FW signal ON), and the FW signal is turned ON again, normal operation is performed.

● **Relationship with DC braking**

When the jogging function is used to perform inching, the inverter sometimes does not come to an exact stop in applications such as turntables and rotates an extra bit more before it comes to a stop.

In vector control, the braking torque just before the stop can be adjusted so that the inverter comes to an exact stop by adjusting the speed adjuster (ASR). However, in V/f control, sufficient braking torque sometimes cannot be ensured simply by adjusting the torque boost.

In cases like these, jogging operation and the DC braking function are used in combination to adjust inching.

For details on DC braking, refer to *7-5-1 DC Injection Braking (DB)* on page 7-63.

Operation when the RUN command is turned OFF during jog operation with the DB (DC braking) terminal turned ON is as follows.

(Example: When External DC Injection Braking Edge/Level Selection (E115) = “1: Level operation”)

- When E111 = 0, 3, operation immediately becomes free run when the RUN command turns OFF, and immediately DC braking by the DB terminal operates.

- When E111 = 1, 2, 4, 5, DC braking by the DB terminal operates immediately when the RUN command turns OFF.

● **Forward Rotation Jogging/Reverse Rotation Jogging**

- When the FJOG (Forward rotation jogging) terminal or RJOG (Reverse rotation jogging) terminal is turned ON when the RUN command is OFF, forward rotation or reverse rotation jogging operation can be performed. Deceleration stop is performed according to the acceleration/deceleration time regardless of E111.

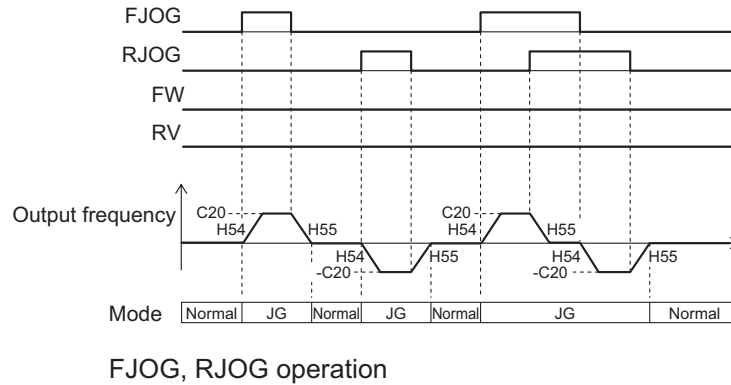
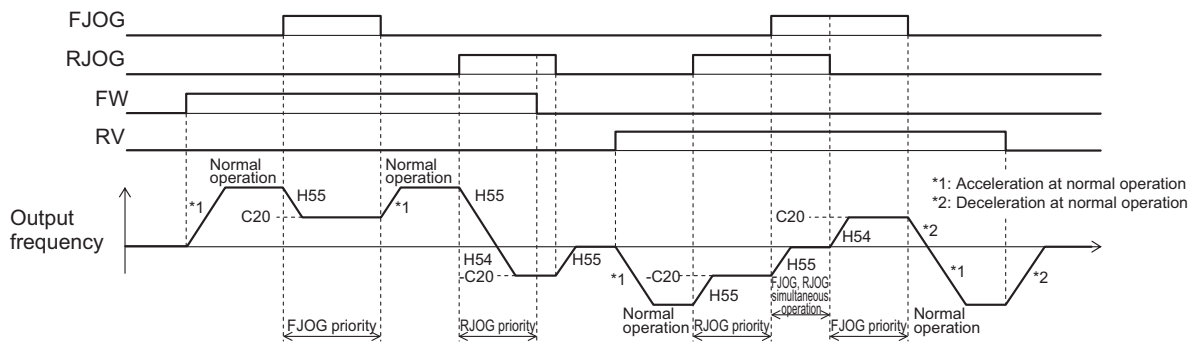

Fig.: Jogging operation by FJOG and RJOG terminals during an operation stop



FJOG, RJOG ON while FW, RV are ON

Fig.: Jogging operation by FJOG and RJOG terminals while inverter is running

- When the FJOG (Forward rotation jogging) terminal and RJOG (Reverse rotation jogging) terminal are both ON, operation is the same as when they are both OFF.
- Operation during a stop follows the setting of Jogging Operation Selection (E111), though the enabled/disabled during operation settings are not affected.
- FJOG (Forward rotation jogging) terminal and RJOG (Reverse rotation jogging) terminal are given priority over jogging operation by the FW terminal/RV terminal and the JG terminal.

Parameter No.	Function name	Data	Default data	Unit
E01 to E05, E98, E99	Input Terminal [DI1] Function Selection to Input Terminal [DI7] Function Selection	94: FJOG (Forward rotation jogging) 95: RJOG (Reverse rotation jogging)	-	-

- Operation when FW and RV turn ON while FJOG and RJOG are ON is as follows.

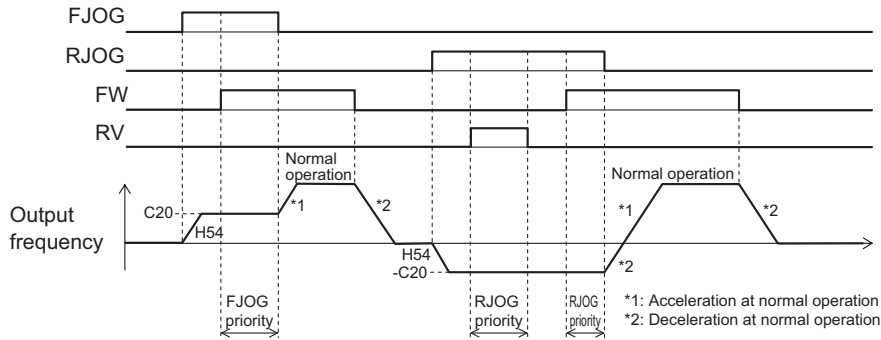

FW, RV ON while FJOG, RJOG are ON

- Combinations of the JG terminal and FJOG terminal, RJOG terminal while jogging during operation is enabled act as follows.

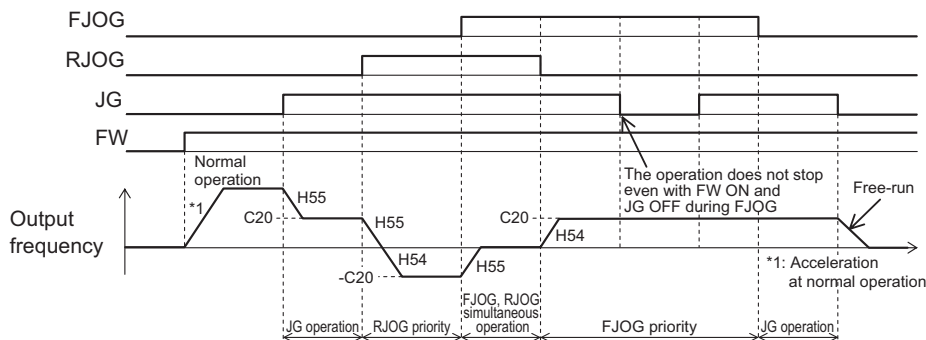

Combinations of JG and FJOG, RJOG while jogging during operation is enabled

### ● Jogging function via communication

- When Extension Function 1 (d99) bit 3 is "0: Jogging Disable via communications," this function is enabled only when 1st RUN Command Selection (F02) is "1: External signal (digital input)."
- When Extension Function 1 (d99) bit 3 is "1: Jogging Enable via communications," forward rotation jogging or reverse rotation jogging operations are possible by the command arriving via communication regardless of the value of d99 bit 3. When commands via communication are enabled, input terminal is disabled.

Parameter No.	Function name	Data	Default data	Unit
E01 to E05, E98, E99	Input Terminal [DI1] Function Selection to Input Terminal [DI7] Function Selection	10: JG (Jogging) 94: FJOG (Forward rotation jogging) 95: RJOG (Reverse rotation jogging)	-	-

Parameter No.	Function name	Data	Default data	Unit
S06	Operation command (Communication Data Terminal [DI])	0000 to FFFF hex  bit 15: RST Bit14: DI7 Bit13: DI6 Bit12: --- Bit11: --- Bit10: --- Bit9: --- Bit8: --- Bit7: --- Bit6: DI5 Bit5: DI4 Bit4: DI3 Bit3: DI2 Bit2: DI1 Bit1: REV Bit0: FWD	0	-

- Allocate this function to “10: JG (Jogging),” “94: FJOG (Forward rotation jogging)” and “95: RJOJ (Reverse rotation jogging)” input terminals in Input Terminal [DI1] Function Selection to Input Terminal [DI7] Function Selection, and operate S06 via communication to perform jogging.

### ● Adjustment of jogging operation

- This function is for adjusting the speed control during jogging operation. As this speed control parameter is used only in jogging operation, jogging operation with a speed response faster than during normal operation can be performed.
- For details on parameters for the speed control jogging operation, refer to the parameters (d01 to d06) for speed control during normal operation that are applicable in *6-5-1 Speed Control Settings* on page 6-26. There are no parameters relating to the notch filter for jogging.

## 2-step acceleration/deceleration

- For details on the 2-step acceleration/deceleration function, refer to *5-6-4 2-step Acceleration/Deceleration Function* on page 5-43.

## Reset

- For details on a reset, refer to *5-8-1 Reset Function* on page 5-49.

# 5-10 Multi-function output

## 5-10-1 Output Terminal Functions

- Inverter status can be output from output terminals by allocating functions to output terminals [DO1], [DO2], [ROA/B/C] (Relay output). For details on other functions, refer to 7-2 *Multifunction Input/Output Functions List* on page 7-26.

Parameter No.	Function name	Data	Default data	Unit
E20, E21, E27	Output Terminal [DO1] Function Selection Output Terminal [DO2] Function Selection Output Terminal [ROA, ROB] Function Selection	Refer to the table below or 7-2 <i>Multifunction Input/Output Functions List</i> on page 7-26.	-	-
H309	Output Terminal [DO1] ON Delay Time	0.0 to 100.0	0.0	s
H311	Output Terminal [DO2] ON Delay Time			
H313	Output Terminal [ROA, ROB] ON Delay Time			
H310	Output Terminal [DO1] OFF Delay Time	0.0 to 100.0	0.0	s
H312	Output Terminal [DO2] OFF Delay Time			
H314	Output Terminal [ROA, ROB] OFF Delay Time			

- Set this at Output Terminal [DO1] Function Selection (E20), Output Terminal [DO2] Function Selection (E21) and Output Terminal [ROA, ROB] Function Selection (E27).
- An NO contact output can be changed to an NC contact output by setting data in which 1000 is added to the set data, and, as a result, the operations of set signals are reversed.
- Each multifunction output terminal can be allocated with the ON/OFF delay time independently.
- Multifunction output terminals DO1 and DO2 are open collector outputs, and multifunction output terminals ROA/B/C (Relay output) are relay outputs.
- The following functions have an OFF delay time of 0.1 s even if the OFF delay time is not set. When these functions are allocated to output terminals, the OFF delay becomes the time obtained by adding 0.1 s to Output Terminal [DO1] OFF Delay Time (H310), Output Terminal [DO2] OFF Delay Time (H312) and Output Terminal [ROA, ROB] OFF Delay Time (H314).
  - Thermistor detection (56: MOH) terminal, Inverter output limited (5: IOL) terminal, Electronic thermal warning (7: THM) terminal, Overload prevention control in progress (36: OLP) terminal, Overload early warning 2 (37: OL2) terminal, Overload early warning (38: OL) terminal, Low current signal (41: LOC) terminal, PID deviation excessive (42: OD) terminal, PID wakeup timer stopped (44: PID-STP) terminal, Overtorque (46: OTQ) terminal

Parameter No.	Data	Function name	Reference item	Reference page
Output Terminal [DO1] Function Selection (E20),	0	RUN (Signal during run)	Signal during run	page 5-68
	1	FA1 (Constant speed arrival signal)	Constant speed arrival signal	page 5-70
Output Terminal [DO2] Function Selection (E21)	99	AL (Alarm signal)	Alarm signal	page 5-71
	70	ZS (0 Hz detection signal)	0 Hz detection signal	page 5-71
Output Terminal [ROA, ROB] Function Selection (E27)	10	IRDY (Operation ready completion)	Operation ready completion	page 5-68
	52	FWR (Forward run signal)	Forward run signal	page 5-69
	53	RVR (Reverse run signal)	Reverse run signal	page 5-69

## Operation Ready Completion Signal (IRDY)

- This signal is output when the inverter becomes ready to operate (ready to accept the RUN command).
- To output this signal, allocate “10: IRDY (Operation ready)” to Output Terminal [DO1] Function Selection (E20), Output Terminal [DO2] Function Selection (E21) or Output Terminal [ROA, ROB] Function Selection (E27).

Parameter No.	Function name	Data	Default data	Unit
E20, E21	Output Terminal [DO1] Function Selection, Output Terminal [DO2] Function Selection	10: IRDY (Operation ready completion)	-	-
E27	Output Terminal [ROA, ROB] Function Selection		99	-

- When this signal is not output, the inverter does not operate even if the RUN command is input.
- If this signal is not output, check if the input power supply voltage (L1/R, L2/S, L3/T) is within the specification range.

## Signal during RUN (RUN), Inverter Output Signal (RUN2)

- This signal is output while the inverter is running (RUN command ON).
- The signal during RUN (RUN) and inverter output signal (RUN2) are output also when the inverter is decelerating after the RUN command turns OFF.
- When in a free-run state (output shutoff status), the signal during RUN (RUN) and inverter output signal (RUN2) are not output even if the RUN command is turned ON. (Note that on the Operator, the RUN LED is lit when the RUN command is ON.)
- The signal during RUN (RUN) is not output while DC braking is operating, during tuning of motor parameters while stopped, and during pre-excitation by the EXITE terminal. The inverter output signal (RUN2) is output.
- To output this signal, allocate “00: RUN” and “35: RUN2” to Output Terminal [DO1] Function Selection (E20), Output Terminal [DO2] Function Selection (E21) or Output Terminal [ROA, ROB] Function Selection (E27).

Parameter No.	Function name	Data	Default data	Unit
E20, E21	Output Terminal [DO1] Function Selection, Output Terminal [DO2] Function Selection	0: RUN (Signal during RUN)	-	-
E27	Output Terminal [ROA, ROB] Function Selection	35: RUN2 (Inverter output in progress)	99	-
Related function				

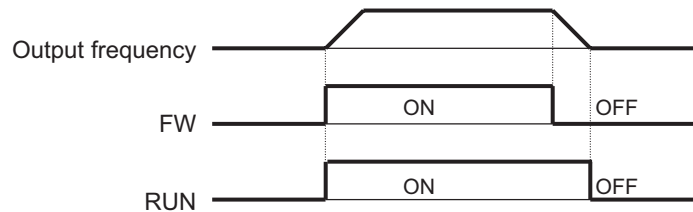

Fig. OFF when at stop frequency and starting frequency or below

## Forward Run Signal (FWR)

- This signal is output while the inverter performs forward operation.
- To output this signal, allocate “52: FWR (Forward run signal)” to Output Terminal [DO1] Function Selection (E20), Output Terminal [DO2] Function Selection (E21) or Output Terminal [ROA, ROB] Function Selection (E27).

Parameter No.	Function name	Data	Default data	Unit
E20, E21	Output Terminal [DO1] Function Selection, Output Terminal [DO2] Function Selection	52: FWR (Forward run signal)	-	-
E27	Output Terminal [ROA, ROB] Function Selection		99	-

- This signal is not output while the inverter performs reverse operation, when it is stopped or during free-run. Note, however, that during control methods with sensor, judgment is performed based on the speed detection value to output the signal even in free-run status.

## Reverse Run Signal (RVR)

- This signal is output while the inverter performs reverse operation.
- To output this signal, allocate “53: RVR (Reverse run signal)” to Output Terminal [DO1] Function Selection (E20), Output Terminal [DO2] Function Selection (E21) or Output Terminal [ROA, ROB] Function Selection (E27).

Parameter No.	Function name	Data	Default data	Unit
E20, E21	Output Terminal [DO1] Function Selection, Output Terminal [DO2] Function Selection	53: RVR (Reverse run signal)	-	-
E27	Output Terminal [ROA, ROB] Function Selection		99	-

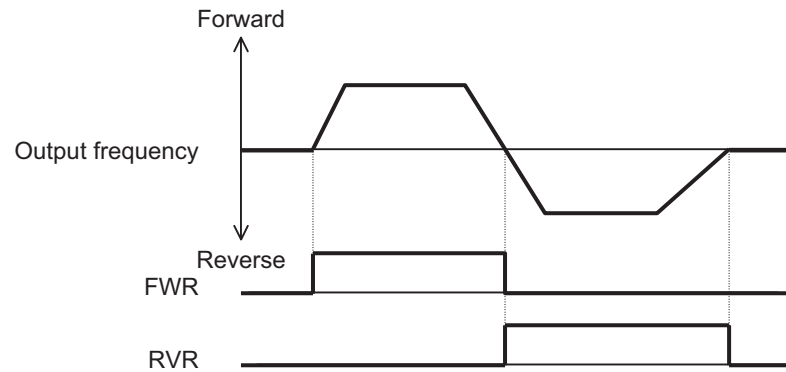

- This signal is not output while the inverter performs forward operation, when it is stopped or during free-run. Note, however, that during control methods with sensor, judgment is performed based on the speed detection value to output the signal even in free-run status.

## Frequency Arrival 1 (Constant Speed) (FAR1)

- This signal is output when the output frequency arrives at the frequency reference.
- To output this signal, allocate “1: FAR1 (Frequency arrival 1 (constant speed))” to Output Terminal [DO1] Function Selection (E20), Output Terminal [DO2] Function Selection (E21) or Output Terminal [ROA, ROB] Function Selection (E27).
- The detection width of the frequency arrival signal is set at Frequency Arrival Detection Width (FAR1/FAR2/FAR3/FDT3/FDT4) (E30).

Parameter No.	Function name	Data	Default data	Unit
E20, E21	Output Terminal [DO1] Function Selection, Output Terminal [DO2] Function Selection	1: FAR1 (Frequency arrival 1 (constant speed))	-	-
E27	Output Terminal [ROA, ROB] Function Selection		99	-
E30	Frequency Arrival Detection Width (FAR1/FAR2/FAR3/FDT3/FDT4)	0.0 to 10.0 Hz	2.5	Hz
Related function				

- When the output frequency is within the range of  $\pm$  Frequency Arrival Detection Width (FAR1/FAR2/FAR3/FDT3/FDT4) (E30) centering around the frequency reference, ON is output, and when it is outside the range, this signal turns OFF.
- During free-run or when the set frequency is less than the stop frequency, the RUN command turns OFF, and turns OFF during a deceleration stop.
- The figure below shows an example of changing the frequency reference from frequency reference (1) to frequency reference (2).



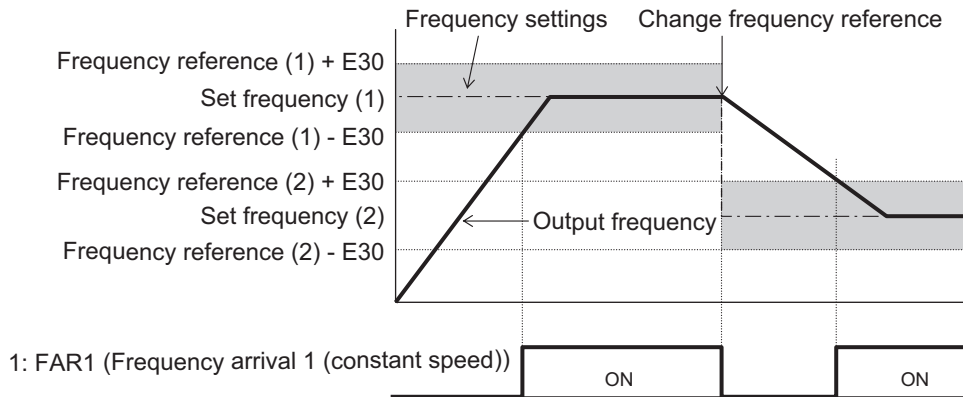

## Alarm Signal (AL)

- The inverter detects an overcurrent, overvoltage, or some other abnormality, and outputs an alarm signal (AL).
- To output this signal, allocate “99: AL (Alarm signal)” to Output Terminal [DO1] Function Selection (E20), Output Terminal [DO2] Function Selection (E21) or Output Terminal [ROA, ROB] Function Selection (E27). The alarm signal is the default data of Output Terminal [ROA, ROB] Function Selection (E27).
- A trip state can be canceled by resetting the inverter, by which the alarm signal is also turned OFF. To reset the inverter, press the  key on the Digital Operator or turn the reset terminal ON. (Refer to 5-8-1 *Reset Function* on page 5-49.)

Parameter No.	Function name	Data	Default data	Unit
E20, E21	Output Terminal [DO1] Function Selection, Output Terminal [DO2] Function Selection	99: AL (Alarm signal)	-	-
E27	Output Terminal [ROA, ROB] Function Selection		99	-

## 0 Hz Detection Signal (ZS)

- This signal is output when the output frequency of the inverter falls below the 0Hz Detection Output Detection Level (ZS) (E199).
- To output this signal, allocate “70: ZS (0 Hz detection signal)” to Output Terminal [DO1] Function Selection (E20), Output Terminal [DO2] Function Selection (E21) or Output Terminal [ROA, ROB] Function Selection (E27).

Parameter No.	Function name	Data	Default data	Unit
E20, E21	Output Terminal [DO1] Function Selection, Output Terminal [DO2] Function Selection	70: ZS (0 Hz detection signal)	-	-
E27	Output Terminal [ROA, ROB] Function Selection		99	-
E199	0Hz Detection Output Detection Level (ZS)	0.00 to 100.00	0.00	Hz

- This signal is output when the output frequency of the inverter falls below the 0Hz Detection Output Detection Level (ZS) (E199) also when the RUN command is OFF.
  - This signal turns ON if the speed command value (output frequency) or the speed detection value is less than the 0Hz Detection Output Detection Level (E199), and turns OFF if it is at E199 or higher regardless of the alarm status or free-run after the power is turned ON.

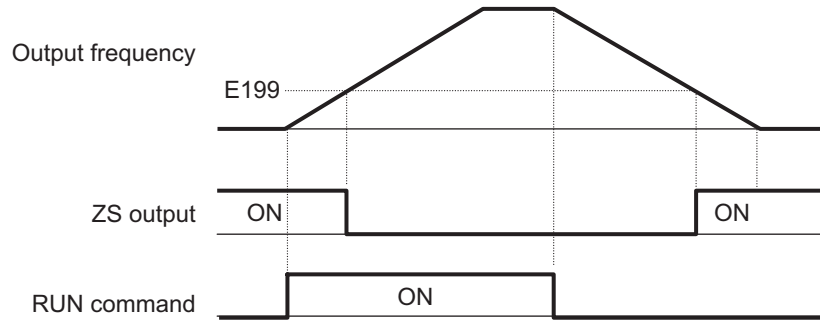

# 5-11 Torque Boost Function

## 5-11-1 Torque Boost

- The torque boost function is for increasing the output torque if it is not sufficient at lower speeds.
- This inverter provides two torque boost options: Manual torque boost for manual torque adjustment and Automatic torque boost for automatic torque adjustment.
- Automatic torque boost is enabled when “0: IM V/f control,” “1: IM Dynamic torque vector control without speed sensor,” “3: IM V/f control with speed sensor” or “4: IM Dynamic torque vector control with speed sensor” is selected at Drive Control Selection (F42/A14).
- Manual torque boost is enabled when “0: IM V/f control” or “3: IM V/f control with speed sensor” is selected at Drive Control Selection (F42/A14).
- The default is automatic torque boost set to enabled. (1st Torque Boost Function Selection (E112)/2nd Torque Boost Function Selection (E113) = 1)

Parameter No.	Function name	Data	Default data	Unit
F42	1st Drive Control Selection	0: IM V/f control 1: IM Dynamic torque vector control without speed sensor 3: IM V/f control with speed sensor 4: IM Dynamic torque vector control with speed sensor	0	-
A14	2nd Drive Control Selection			
E112	1st Torque Boost Function Selection	0: Manual torque boost 1: Automatic torque boost	1	-
E113	2nd Torque Boost Function Selection			
F09	1st Manual Torque Boost Voltage	0.0% to 20.0% (percentage with respect to 1st Rated Voltage at Base Frequency (F05)/2nd Rated Voltage at Base Frequency (A03))	1.9	%
A05	2nd Manual Torque Boost Voltage			
Related function		Motor Capacity (P02/A16), Base Frequency (F04/A02), Rated Voltage at Base Frequency (F05/A03), Motor Parameters (P01/A15 to P03/A17 and P06/A20 to P20/A34)		

### Automatic Torque Boost (E112/E113 = 1)

- With this setting, the inverter increases the output voltage automatically depending on the load condition.
- When automatic torque boost function is enabled, the non-linear V/f function is disabled.
- To use the automatic torque boost function, either set 1st Base Frequency (F04), 1st Rated Voltage at Base Frequency (F05) and motor parameters (P01 to P03 and P06 to P95) to match the motor capacity or motor characteristics, or execute auto-tuning (P04).
- To use automatic torque boost, set “1: Constant torque load” to 1st V/f Characteristics Selection (F37) and 2nd V/f Characteristics Selection (A13). When “0: Variable torque load” is set, manual torque boost is selected regardless of the setting of Torque Boost Function Selection (E112/E113).

- Automatic torque boost controls to match the motor characteristics. Either set Base Frequency (F04/A02), Rated Voltage at Base Frequency (F05/A03) and motor parameters (P01/A15 to P03/A17 and P06/A20 to P20/A34) to match the motor capacity or motor characteristics, or execute auto-tuning.

## Manual Torque Boost (E112/E113 = 0)

- With the torque boost by Manual Torque Boost Voltage (F09/A05), a constant voltage is added to the V/f characteristics before output regardless of the load. The optimum voltage suited to the motor and load are manually adjusted by the Manual Torque Boost Voltage (F09/A05) to ensure starting torque. Adjust the voltage to a level at which startup is possible and overexcitation does not occur in a no-load state or light load state.
- When the non-linear V/f function is used in combination with the manual torque boost function, the torque boost is enabled at the lowest non-linear V/f frequency or less.

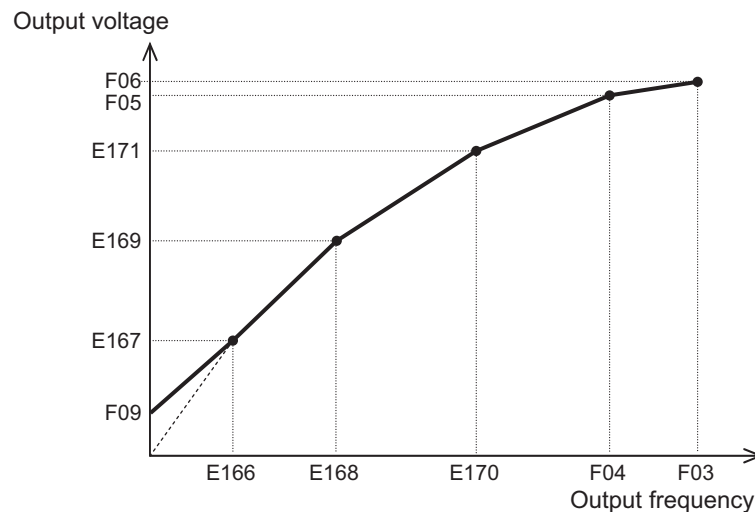

- When Manual Torque Boost Voltage (F09/A05) is set to 0.0%, manual torque boost is disabled.

## 5-12 Regenerative Braking Function

### 5-12-1 Regenerative Braking Function

- During motor deceleration and elevator descent, regenerative energy sometimes is returned to the inverter and an overvoltage is detected due to an excessive regenerative amount.
- The regenerative braking function uses the built-in or an external regenerative braking resistor to decrease the internal Main Circuit DC Voltage of the inverter by converting the regenerated energy from the motor into heat via external braking resistors.
- The 3G3M1 Series has a built-in regenerative braking circuit and a regenerative braking function operates at all times regardless of whether the inverter is running or has stopped.

### 5-12-2 Braking Resistor Electronic Thermal Function

- Either use a braking resistor with thermal contact or use the braking resistor electronic thermal function for overheat protection of the external braking resistor.
- Use the braking resistor electronic thermal function by setting the discharge capacity, allowable average loss and resistance value to each of F50, F51 and F52. These values are determined by inverter model and type of braking resistor.
- To use the regenerative braking function, set Anti-regenerative Control Function Selection (H69) to "0: Disable."

Parameter No.	Function name	Data	Default data	Unit
F50	Electronic Thermal for Braking Resistor Discharging Capacity	1 to 9000 32767: Cancel	32767	kWs
F51	Electronic Thermal for Braking Resistor Allowable Average Loss	0.001 to 99.99	0.001	kW
F52	Braking resistor electronic thermal braking resistance	0.01 to 999	0.01	Ω
W161	Braking resistor thermal calculated value	0.0 to 100.0	0.0	%
Related function		Anti-regenerative Control Function Selection (H69)		

- Set the Electronic Thermal for Braking Resistor Discharging Capacity (F50) and Electronic Thermal for Braking Resistor Allowable Average Loss (F51) by the following formula depending on how the braking load is applied.

#### ● When braking load during deceleration decreases with time

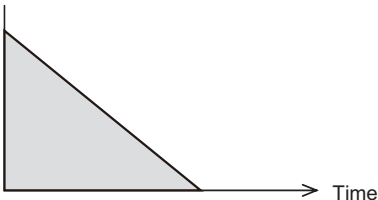
How to apply a braking load	Allowable average loss	Thermal braking resistance value
Braking load (kW) 	Electronic Thermal for Braking Resistor Discharging Capacity (F50) = $\frac{\text{Braking time (s)} \times \text{Motor capacity (kW)}}{2}$	Electronic Thermal for Braking Resistor Allowable Average Loss (F51) = $\frac{\frac{\%ED(\%)}{100} \times \text{Motor capacity (kW)}}{2}$

● When braking load at deceleration is a constant speed

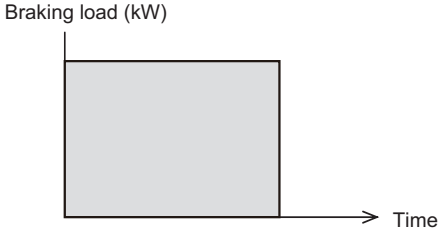
How to apply a braking load	Allowable average loss	Thermal braking resistance value
	<p>Electronic Thermal for Braking Resistor Discharging Capacity (F50) =</p> <p>Braking time (s) × Motor capacity (kW)</p>	<p>Electronic Thermal for Braking Resistor Allowable Average Loss (F51) =</p> $\frac{\%ED(\%)}{100} \times \text{Motor capacity (kW)}$



**Additional Information**

- When a braking resistor capable of outputting a temperature detection signal is applied, set “9: EXT (external trip)” to one of Input Terminal [DI1] Function Selection to Input Terminal [DI7] Function Selection (E50 to E55, E98, E99), and connect the temperature detection signal of the braking resistor.
- Even if there is actually little temperature rise, the electronic thermal sometimes is activated and the overheating protection dbH alarm is generated depending on the braking resistor specifications. Check the specifications of the braking resistor and set its parameter.

# 6

## Vector Control and Applied Functions

This section describes the vector control and applied functions characteristic of this inverter.

<b>6-1</b>	<b>Details of Motor Control Methods.....</b>	<b>6-3</b>
6-1-1	Motor Control Methods.....	6-3
6-1-2	Basic Motor Parameter Settings.....	6-4
6-1-3	Motor Parameter Settings.....	6-6
<b>6-2</b>	<b>V/f control with speed feedback .....</b>	<b>6-11</b>
6-2-1	Settings of V/f Control with Speed Feedback.....	6-11
6-2-2	Protective Detection under V/f Control with Speed Feedback .....	6-12
6-2-3	Adjustments for V/f Control with Speed Feedback.....	6-14
<b>6-3</b>	<b>Sensorless Vector Control .....</b>	<b>6-16</b>
6-3-1	Sensorless Vector Control Parameter Settings.....	6-16
6-3-2	Motor Parameter Settings .....	6-17
6-3-3	Adjustments for Sensorless Vector Control.....	6-18
<b>6-4</b>	<b>PM Motor Mode.....</b>	<b>6-20</b>
6-4-1	PM Motor and PM Motor Control.....	6-20
6-4-2	Switching to PM Motor Mode .....	6-21
6-4-3	Offline Auto-tuning for PM Motor Parameters .....	6-22
6-4-4	Adjustment of PM Motor Mode Settings.....	6-22
<b>6-5</b>	<b>Speed Control.....</b>	<b>6-26</b>
6-5-1	Speed Control Settings .....	6-26
<b>6-6</b>	<b>Torque Control.....</b>	<b>6-31</b>
6-6-1	Torque Control Settings.....	6-31
6-6-2	Torque Bias Function Settings.....	6-33
<b>6-7</b>	<b>Position Control .....</b>	<b>6-36</b>
6-7-1	Basic Operation.....	6-36
6-7-2	Position Control Gain .....	6-38
6-7-3	Electronic Gear.....	6-39
6-7-4	Acceleration/Deceleration Time Selection.....	6-40
6-7-5	Positioning Data .....	6-41
6-7-6	Overtravel (OT) .....	6-43
6-7-7	Software OT .....	6-43
6-7-8	Basic Return-to-origin Operation.....	6-44
6-7-9	Clearing of Position .....	6-48
6-7-10	Position Preset .....	6-49
6-7-11	Orientation.....	6-49
6-7-12	Functions That Are Disabled in Position Control.....	6-57

6-7-13	Position Monitor.....	6-57
6-7-14	Restarting Positioning .....	6-58
6-7-15	Brake Control during Position Control .....	6-58
6-7-16	Position Store Selection at Power OFF.....	6-61
6-7-17	Excessive Positional Deviation.....	6-61
6-7-18	Touch Probe (Latch) Function .....	6-62
<b>6-8</b>	<b>Motor tuning .....</b>	<b>6-65</b>
6-8-1	Motor Off-line Auto-tuning .....	6-65
6-8-2	Online Tuning .....	6-71
<b>6-9</b>	<b>Brake Control Function .....</b>	<b>6-72</b>
6-9-1	Operation Sequence of Brake Control Function.....	6-72
6-9-2	Brake Control Function Settings.....	6-76
<b>6-10</b>	<b>Application Control .....</b>	<b>6-78</b>
6-10-1	Application Control Settings .....	6-78
<b>6-11</b>	<b>Torque Limit Function.....</b>	<b>6-81</b>
6-11-1	Torque Limit Function Settings .....	6-81
6-11-2	Torque Monitor .....	6-83
<b>6-12</b>	<b>Overtorque/Undertorque Function .....</b>	<b>6-85</b>
6-12-1	Overtorque/Undertorque Function Settings.....	6-85



## 6-1 Details of Motor Control Methods

Select the control method best suited to type of motor to be driven and application. Set the control method to be used in 1st Drive Control Selection (F42)/2nd Drive Control Selection (A14).

Available control methods differ according to the type of motor.

Vector control without speed sensor and vector control with speed sensor can be set only to 1st motor control.

### 6-1-1 Motor Control Methods

#### Dynamic Torque Vector Control (Induction Motor)

To make full use of motor torque, torque corresponding to load is calculated, and the voltage/current vector is optimally controlled according to that calculated value. When dynamic torque vector control is selected, automatic torque boost and slip compensation are automatically enabled. This function is useful for enhancing response to load fluctuation or other external disturbances and improving the speed control accuracy of the motor. Note, however, that this control is open loop V/f control and does not control current like in vector control. For this reason, response to sudden load external disturbances may not be possible, though it does have advantages such as a maximum torque larger than that of vector control.

#### Dynamic Torque Vector Control with Speed Sensor (Induction Motor)

With regard to V/f control with speed sensor, to make full use of motor torque, torque corresponding to load is calculated, and the voltage/current vector is optimally controlled according to that calculated value. This control is useful for enhancing response to load fluctuation or other external disturbances and improving the speed control accuracy of the motor.

#### Speed Sensorless Vector Control (Induction Motor)

Speed control is performed based on the motor speed inferred from voltage and current, motor current is further divided into excitation current and torque current, and vector control for controlling each of these currents is performed. The required response can be achieved by adjusting the control constants (PI constants) with speed control (PI controller).

With vector control, a certain degree of difference (voltage margin) between the induction voltage of the motor and voltage that can be output from the inverter is required as motor current is controlled. Generally, the voltage of a general-purpose motor is matched to the commercial power supply. However, due to the necessity for this voltage margin, the terminal voltage of the motor must be kept low when performing control. When the terminal voltage of the motor is kept low when performing control, the rated torque of the motor cannot be output even if the rated current of the motor according to specification is applied. To ensure the rated torque, the rated current must be increased (the same applies in vector control with speed sensor).

### **Vector Control with Speed Sensor (Induction Motor)**

Speed control is performed based on the motor rotation position and speed detected according to the feedback signal from the motor's PG, motor current is further divided into excitation current and torque current, and vector control for controlling each of these currents is performed. The required response can be achieved by adjusting the control constants (PI constants) with speed control (PI controller). Compared with speed sensorless vector control, vector control with speed sensor affords speed control with even higher accuracy and faster response.

### **Sensorless Vector Control (Synchronous Motor)**

Speed control is performed based on the motor speed inferred from voltage and current, motor current is further divided into excitation current and torque current, and vector control for controlling each of these currents is performed. The required response can be achieved by adjusting the control constants (PI constants) of speed control (PI controller).

### **Vector Control with Speed Sensor (Synchronous Motor)**

Speed control is performed based on the motor rotation speed and magnetic pole position detected according to the feedback signal from the motor's speed/magnetic pole position sensor, motor current is further divided into excitation current and torque current, and vector control for controlling each of these currents is performed. The required response can be achieved by adjusting the control constants (PI constants) of speed control (PI controller). Compared with sensorless vector control, vector control with sensor affords a wider speed control range and speed control with higher response.

## **6-1-2 Basic Motor Parameter Settings**

Set the basic parameters for motor control and protection.

Setting the correct motor parameters to the inverter is effective in stabilizing motor behavior as appropriate values are obtained for the control result.

- Match the base frequency to the rated frequency stipulated for the motor. Setting the base frequency lower than the rated frequency might result in motor burnout.
- The rated frequency of a general induction motor is designed to be within the range 50 to 60 Hz. When setting the maximum frequency to 60 Hz or higher, check the maximum allowable frequency in the motor specifications. Setting a maximum frequency and rated voltage exceeding the motor specifications might result in motor burnout.

## Basic Parameter Settings

Item	Inverter parameter		Setting range	Description	Default value
Capacity	P02/A16	1st Motor Capacity/2nd Motor Capacity	0.01 to 1000 kW	Sets the motor capacity.	Dependent on capacity
Number of poles	P01/A15	1st Motor Pole Number/2nd Motor Pole Number	2 to 128 poles	Sets the number of poles of the motor.	4
Frequency	F04/A02	1st Base Frequency/2nd Base Frequency	5.0 to 590.0 Hz	Sets the base frequency of the motor.	50.0
	F03/A01	1st Maximum Output Frequency/2nd Maximum Output Frequency	5.0 to 590.0 Hz	Sets the maximum frequency of the motor.	60.0
Voltage	F05/A03	1st Rated Voltage at Base Frequency/2nd Rated Voltage at Base Frequency	80 to 240 V: AVR operation (200 V class series) 160 to 500 V: AVR operation (400 V class series)	Sets the base voltage of the motor.	Dependent on capacity
	F06/A04	1st Rated Voltage at Maximum Output Frequency/2nd Rated Voltage at Maximum Output Frequency	80 to 240 V: AVR operation (200 V class series) 160 to 500 V: AVR operation (400 V class series)	Sets the maximum voltage of the motor.	Dependent on capacity
Current	P03/A17	1st Motor Rated Current/2nd Motor Rated Current	0.00 to 500.0 A	Set the rated current of the motor.	Dependent on capacity

## Capacity and Number of Poles

Set the capacity and number of poles of the motor.

Note that when the capacity is changed, specific parameters on the inverter are initialized to their factory defaults.

After setting the capacity, either perform auto-tuning or manual input the motor constants that have been prepared.

When the correct motor constants are set, operation is optimized so it becomes stable.

Cleared default values are for auto-tuning, and action may not be as expected if the values deviate from actual motor constants. For this reason, ensure that the motor constants are set correctly.

## Base Frequency/Base Voltage

Match 1st Base Frequency (F04)/2nd Base Frequency (A02) and 1st Rated Voltage at Base Frequency (F05)/2nd Rated Voltage at Base Frequency (A03) to the rated frequency and rated voltage of the motor.

The base frequency is found as follows from the rated rotation speed (min<sup>-1</sup>) of the motor and the number of poles.

- Base frequency (Hz) = Rated rotation speed (min<sup>-1</sup>) × number of poles/120

## Maximum Frequency/Maximum Output Voltage

Set the maximum frequency and maximum output voltage of the motor.

## Rated Current

Set the motor rated current matched to the motor specifications. Motor protection sometimes does not function properly if the motor rated current is not set properly.

Also, motor control sometimes becomes unstable if the motor rated current is not set properly.

### 6-1-3 Motor Parameter Settings

When motor parameters are correctly set matched to the motor control method, control is compensated and motor behavior is stabilized.

Note that when the capacity is changed, specific parameters on the inverter are initialized to their factory defaults.

After setting the capacity, either perform auto-tuning or manual input the motor constants that have been prepared.

For details on auto-tuning, refer to *6-8-1 Motor Off-line Auto-tuning* on page 6-65.

Save the set parameter values as a user preference dataset so that motor constants can be recovered if they are initialized unintentionally.

For details on the user preference dataset, refer to *5-1-2 Data Initialization* on page 5-4.

Set the following constants according to the settings of 1st Drive Control Selection (F42)/2nd Drive Control Selection (A14).

## Dynamic Torque Vector Control (With/without Speed Sensor) (Induction Motor)

Parameter No.	Function name	Set data	Default data
F42/A14	1st Drive Control Selection/2nd Drive Control Selection	1: IM Dynamic torque vector control 5: IM Vector control without speed sensor	0
F04/A02	1st Base Frequency/2nd Base Frequency	Motor rated value	50.0 Hz
F05/A03	1st Rated Voltage at Base Frequency/2nd Rated Voltage at Base Frequency		Dependent on capacity
P02/A16	1st Motor Capacity/2nd Motor Capacity		Dependent on capacity
P03/A17	1st Motor Rated Current/2nd Motor Rated Current		Dependent on capacity
P06/A20	1st Motor Armature Resistance/2nd Motor Armature Resistance	When rotation tuning can be performed, this does not need to be set. When rotation tuning is not possible, either set the values given in the test report for the motor, or set the value calculated by the following formula. $\sqrt{(P03)^2 - (P55)^2}$	Dependent on capacity
F03/A01	1st Maximum Output Frequency/2nd Maximum Output Frequency	Design specification value	60.0 Hz
F07	1st Acceleration Time 1		6.0 s
F08	1st Deceleration Time 1		6.0 s

## Vector Control (With/without Speed Sensor) (Induction Motor)

Parameter No.	Function name	Set data	Default data
F42/A14	1st Drive Control Selection/2nd Drive Control Selection	4: IM Dynamic torque vector control with speed sensor 6: IM Vector control with speed sensor	0

Parameter No.	Function name	Set data	Default data
F04/A02	1st Base Frequency/2nd Base Frequency	Motor rated value	50.0 Hz
F05/A03	1st Rated Voltage at Base Frequency/2nd Rated Voltage at Base Frequency		Dependent on capacity
P01/A15	1st Motor Pole Number/2nd Motor Pole Number		4
P02/A16	1st Motor Capacity/2nd Motor Capacity		Dependent on capacity
P03/A17	1st Motor Rated Current/2nd Motor Rated Current		Dependent on capacity
P06/A20	1st Motor Armature Resistance/2nd Motor Armature Resistance	When rotation tuning can be performed, this does not need to be set. When rotation tuning is not possible, either set the values given in the test report for the motor, or set the value calculated by the following formula. $\sqrt{(P03)^2 - (P55)^2}$	Dependent on capacity
F03/A01	1st Maximum Output Frequency/2nd Maximum Output Frequency	Design specification value	60.0 Hz
F07	1st Acceleration Time 1		6.0 s
F08	1st Deceleration Time 1		6.0 s

### Vector Control (With/without Speed Sensor) (Synchronous Motor)

Parameter No.	Function name	Set data	Default data
F42	1st Drive Control Selection	15: PM Vector control without speed and pole position sensor 16: PM Vector control with speed and pole position sensor	0
F26	Carrier Frequency	Motor specification	2 kHz
F04	1st Base Frequency	Motor rated value	50.0 Hz
F05	1st Rated Voltage at Base Frequency		Dependent on capacity
P01	1st Motor Pole Number		4
P02	1st Motor Capacity		Dependent on capacity
P03	1st Motor Rated Current		Dependent on capacity

Parameter No.	Function name	Set data	Default data
P30	1st PM Motor Starting Method	0: Pull-in by current 1: For IPM type 1(Interior permanent magnet synchronous motor) 2: For SPM type (Surface permanent magnet synchronous motor) 3: Pull-in by current for IPM type 4: For IPM type 2(Interior permanent magnet synchronous motor)	1
P63	1st PM Motor Induced Voltage Ke	When unknown, perform rotation tuning.	Dependent on capacity
P64	1st PM Motor Iron Loss	When unknown, set 0%.	Dependent on capacity
P90	1st PM Motor Overcurrent Protection Level	When unknown, set 2x the rated current.	Dependent on capacity
F03	1st Maximum Output Frequency	Design specification value	60.0 Hz
F15	1st Frequency Upper Limit		70.0 Hz
F07	1st Acceleration Time 1		6.0 s
F08	1st Deceleration Time 1		6.0 s

## When Control with Speed Sensor Is Selected as Control Method

When a control with speed sensor is selected as the control method, the following parameters matched to the encoder specifications are required.

Parameter No.	Function name	Set data	Default data
d14	Input Terminal [PIA][PIB] Pulse Input Format Selection	2: Quadrature A/B signal (B phase lead) 3: Quadrature A/B signal (A phase lead)	2
d15	Input Terminal [PIA][PIB] Encoder Pulse Resolution	Number of pulses of motor encoder to be controlled 0400 (hexadecimal display) / 1024 P/R	0400 (hexadecimal display)
d16	Input Terminal [PIA][PIB] Pulse Scaling Factor Denominator	Set the speed reduction ratio of the motor and encoder.	1
d17	Input Terminal [PIA][PIB] Pulse Scaling Factor Numerator	When the encoder is directly coupled to the motor, this does not need to be set. (Default value = 1) Motor speed = Encoder speed × (d17) / (d16)	1

## Parameters That Do Not Require Setting

The following table shows parameters whose values are determined by other parameters or parameters that do not need to be changed from their factory default values.

Parameter No.	Function name	Data	Default data	Unit
P13/A27	1st Iron Loss Factor 1/2nd Iron Loss Factor 1	0.00 to 20.00%	Dependent on capacity	%

Parameter No.	Function name	Data	Default data	Unit
P55/A55	1st Motor Torque Current under Vector Control/Torque Current for 2nd Vector Control	0.00 to 2000 A	Dependent on capacity	A
P56/A56	1st Induced Voltage Factor under Vector Control/ Induced Voltage Factor for 2nd Vector Control	50 to 100%	Dependent on capacity	%
P65	1st PM Motor d-axis Inductance Magnetic Saturation Correction	0.0 to 100% (100.0%=No magnetic saturation) 999 (Factory default)	999	%
P74	1st PM Motor Reference Current at Starting	10 to 200% (Based on the rated current of the motor)	80	%
P85	1st PM Motor Flux Limitation Value	50.0 to 150.0% 999 (Factory default)	999	%
P87	1st PM Motor Reference Current for Magnetic Pole Detection	0 to 200% (Based on the rated current of the motor)	0	%



## 6-2 V/f control with speed feedback

The 3G3M1 Series Inverter can perform V/f control with speed feedback by using the pulse train input function mounted as standard.

This control enables highly accurate and stable speed control based on the feedback of the pulse generator (PG) signal or the phase A/B signals from the encoder.

This section describes the settings and functions of V/f control with speed feedback.

### 6-2-1 Settings of V/f Control with Speed Feedback

In this control mode, the inverter can perform highly accurate and stable speed control as V/f control, based on the speed feedback data.

- To use this function, set “3: IM V/f control with speed sensor” at 1st Drive Control Selection (F42)/2nd Drive Control Selection (A14).
- Set the type of the pulse train signal to input in Input Terminal [PIA][PIB] Pulse Input Format Selection (d14), and the number of pulses per one rotation of the motor ( $\times 1$  multiplication) in Input Terminal [PIA][PIB] Encoder Pulse Resolution (d15).
- Set values in Input Terminal [PIA][PIB] Pulse Scaling Factor Denominator (d16) and Input Terminal [PIA][PIB] Pulse Scaling Factor Numerator (d17) according to the speed reduction ratio of the motor and encoder.

Parameter No.	Function name	Data	Default data	Unit
F42/A14	1st Drive Control Selection/ 2nd Drive Control Selection	3: IM V/f control with speed sensor	0	-
d14	Input Terminal [PIA][PIB] Pulse Input Format Selection	0: Pulse train signing/pulse train input 1: Forward/reverse rotation pulse 2: Quadrature A/B signal (B phase lead) 3: Quadrature A/B signal (A phase lead)	2	-
d15	Input Terminal [PIA][PIB] Encoder Pulse Resolution	20 to 60000	1024	Pulse
d16	Input Terminal [PIA][PIB] Pulse Scaling Factor Denominator	1 to 32767	1	-
d17	Input Terminal [PIA][PIB] Pulse Scaling Factor Numerator	1 to 32767	1	-

#### ● Details of Input Terminal [PIA][PIB] Pulse Input Format Selection (d14)

The Input Terminal [PIA][PIB] Pulse Input Format Selection (d14) setting causes the inverter to recognize the feedback rotation direction as shown below.

d14 data	Pulse input method	Remarks
2	Quadrature A/B signal (B phase lead)	
3	Quadrature A/B signal (A phase lead)	When d14 = 2, reverse rotation (A phase lead becomes forward rotation).

The counterclockwise direction (CCW) as viewed from the shaft side is taken as the forward rotation direction of the motors. At this time, if the output pulse of the encoder is B phase lead, set “2: Quadrature A/B signal (B phase lead)” at Input Terminal [PIA][PIB] Pulse Input Format Selection (d14).

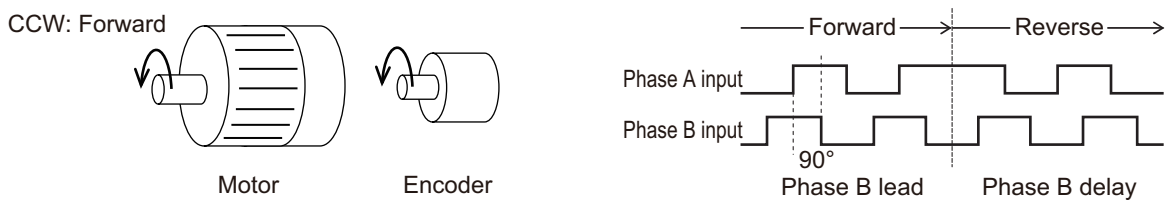

If the output pulse of the encoder is A phase lead, set “3: Quadrature A/B signal (A phase lead)” at Input Terminal [PIA][PIB] Pulse Input Format Selection (d14).

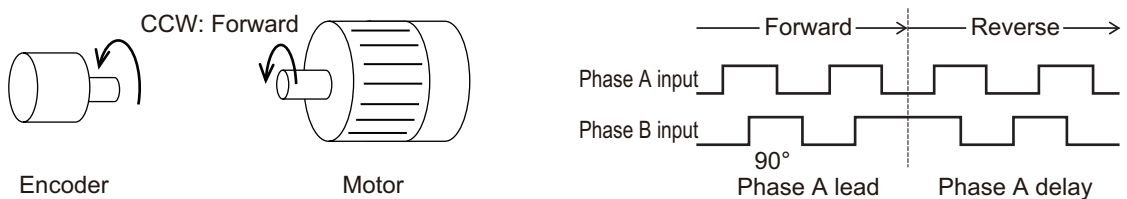

**Additional Information**

In the case of a motor that complies with the IEC Standards, forward rotation causes the motor to rotate clockwise (CW). Either connect the output pulse of the encoder during forward (CW) rotation so that it becomes B phase lead, or set Input Terminal [PIA][PIB] Pulse Input Format Selection (d14) to match the output pulse of the encoder.

**6-2-2 Protective Detection under V/f Control with Speed Feedback**

In V/f control with speed feedback, the following protective detection functions can be used. Use these functions according to your application.

Parameter No.	Function name	Data	Default data	Unit
d21	Speed Agreement / Speed Deviation Error Hysteresis Width	0.0 to 50.0	10.0	%
d22	Speed Agreement / Speed Deviation Error Detection Timer	0.00 to 10.00	0.50	s

Parameter No.	Function name	Data	Default data	Unit
d23	Speed Deviation Error Processing Selection	0: Continue to run 1 1: Stop with alarm 1 2: Stop with alarm 2 3: Continue to run 2 4: Stop with alarm 3 5: Stop with alarm 4	2	-
d32	Speed Limit 1 in Forward	0 to 110	100	%
d33	Speed Limit 2 in Reverse	0 to 110	100	%
d35	Over Speed Detection Level	0 to 120, 999: Depend on d32 and d33	999	%
E01 to E05, E98, E99	Input Terminal [DI1] Function Selection to Input Terminal [DI7] Function Selection	71: DSAG (Speed agreement) 76: DSE (Excessive speed deviation)	-	-

### ● Overspeed error detection

If the output frequency exceeds the overspeed protection level, the inverter detects the overspeed protection alarm OS and shuts off (trips) inverter output.

- Conditions that cause an overspeed protection alarm

Over Speed Detection Level (d35) = 999

<Forward rotation side>      Overspeed detection level = 1st Maximum Output Frequency (F03)/2nd Maximum Output Frequency (A01) × Speed Limit 1 in Forward (d32) (%) × 120 (%)

<Reverse rotation side>      Overspeed detection level = 1st Maximum Output Frequency (F03)/2nd Maximum Output Frequency (A01) × Speed Limit 2 in Reverse (d33) (%) × 120 (%)

Over Speed Detection Level (d35) = Other than 999

Overspeed detection level = 1st Maximum Output Frequency (F03)/2nd Maximum Output Frequency (A01) × Over Speed Detection Level (d35) (%) × 120v(%)

### ● Speed mismatch/excessive speed deviation

If the state where the difference between the frequency reference and the actual frequency exceeds the set value of Speed Agreement / Speed Deviation Error Hysteresis Width (d21) continues for Speed Agreement / Speed Deviation Error Detection Timer (d22), this state is judged to be a speed mismatch/excessive speed deviation, post-detection processing is performed according to the setting of Speed Deviation Error Processing Selection (d23).

d23 data	Function	Detection condition	Post-detection processing	Error detection width when speed command > F04
0	Continue to run 1	When the speed command (after software start processing) cannot be followed due to a heavy overload, for example, and the detection speed drops compared with the speed command, a PG error is not judged.	The excessive speed deviation "DSE" signal is output and the inverter continues to operate.	Even at 1st Base Frequency (F04) or higher, constant at "detection width = $d21 \times$ maximum frequency."
1	Stop with alarm 1		Inverter free-run at ErE alarm	
2	Stop with alarm 2			
3	Continue to run 2	When the speed command (after software start processing) cannot be followed due to a heavy overload, for example, and the detection speed drops compared with the speed command, a PG error is not judged.	The excessive speed deviation "DSE" signal is output and the inverter continues to operate.	At 1st Base Frequency (F04) or lower, constant at "detection width = $d21 \times$ maximum frequency." At 1st Base Frequency (F04) or higher, "detection width = $d21 \times$ speed command $\times$ maximum frequency / base frequency."
4	Stop with alarm 3		Inverter free-run at ErE alarm	
5	Stop with alarm 4			

When Continue to run (0 or 3) is set in Speed Deviation Error Processing Selection (d23), inverter output is not shut off (tripped). For this reason, allocate "76: DSE (excessive speed deviation)" to Output Terminal [DO1] Function Selection (E20), Output Terminal [DO2] Function Selection (E21) or Output Terminal [ROA, ROB] Function Selection (E27), and configure a sequence that, for example, stops control.

To judge that the speed deviation is within the setting range, allocate "71: DSAG (speed agreement)."

### 6-2-3 Adjustments for V/f Control with Speed Feedback

You can adjust the V/f control with speed feedback function with the gain settings shown below. However, the function cannot be adjusted when using a motor that causes an extremely large slip (10% of the rated rotation speed or higher) or in applications where such a large load that causes the motor to stall (or step out) is applied. If so, set the type and capacity of the motor again.

Parameter No.	Function name	Data	Default data	Unit
d03	Speed Control 1 P Proportional Gain	0.1 to 200.0	10.0	time
d04	Speed Control 1 I Integral Time	0.001 to 9.999 999: Cancel integral term	0.100	s

Parameter No.	Function name	Data	Default data	Unit
d70	Speed Control Slip Frequency Limit	0.00 to 100.00	100.00	%

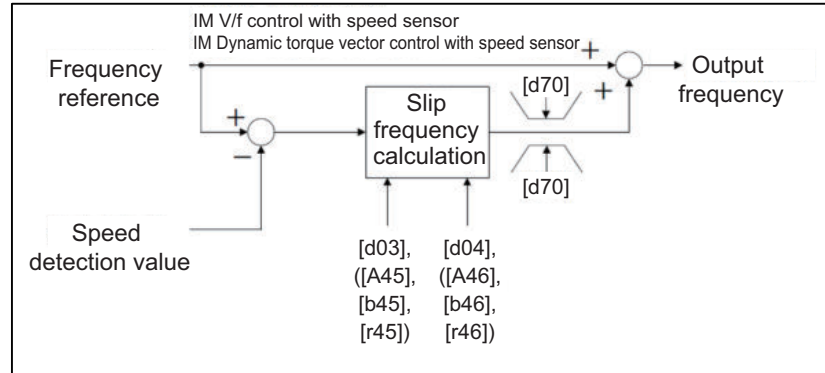

### ● V/f control with speed feedback slip compensation proportional gain

At first, adjust the proportional gain for speed feedback control.

- Check and gradually increase the set value of PG feedback value (monitor mode: 3\_29).
- While checking the PG feedback value (monitor mode: 3\_29), increase the value within the range where the motor speed is stable.
- If the motor speed fluctuates or the motor vibrates wildly, decrease the set value until it becomes stable.
- When adjusting the response if the load is actually activated, increase the set value to improve response, or decrease the set value to make it stable.

### ● V/f control with speed feedback slip compensation integral time

Next, adjust the integral time for speed feedback control.

- Check and gradually decrease the set value of PG feedback value (monitor mode: 3\_29).
- Decrease the value in the PG feedback value (monitor mode: 3\_29) until it matches the reference frequency.
- If the motor speed fluctuates or the motor vibrates wildly, increase the set value until it becomes stable.
- When adjusting the response if the load is actually activated, decrease the set value to improve response, or increase the set value to make it stable.

### ● Speed control limiter

Speed Control Slip Frequency Limit (d70) is the limiter for the slip frequency that is added to the frequency reference. The maximum frequency is taken to be 100%. Ordinarily, leaving this setting at 100% causes no problems.

## 6-3 Sensorless Vector Control

A characteristic of an induction motor is that its rotation speed drops when output torque increases. When sensorless vector control is selected, the relationship between the output torque and rotation speed of an induction motor can be improved and high torque can be output even at low speeds.

Sensorless vector control enables a high starting torque of 200% to be output at 0.5 Hz.

An auto-tuning function (rotation method, stop method) that automatically sets motor constants also is mounted on the inverter.

### 6-3-1 Sensorless Vector Control Parameter Settings

- Set the 1st Drive Control Selection (F42)/2nd Drive Control Selection (A14) to “5: IM Vector control without speed sensor.”
- Set 1st Motor Capacity (P02)/2nd Motor Capacity (A16), 1st Motor Pole Number (P01)/2nd Manual Torque Boost Voltage (A05), 1st Motor Rated Current (P03)/2nd Motor Rated Current (A17) according to the motor in use.
- When rotation tuning is not possible, set 1st Motor Armature Resistance (P06)/2nd Motor Armature Resistance (A20) by the formula below. When rotation tuning is possible, setting is not required.

$$\sqrt{(P03)^2 - (P55)^2}$$

- Set the rated frequency of the motor to 1st Base Frequency (F04)/2nd Base Frequency (A02), and set the motor rated voltage to 1st Rated Voltage at Base Frequency (F05)/2nd Rated Voltage at Base Frequency (A03). If the motor synchronous speed can be confirmed, set the value calculated by the formula below to F04/A02.

$$\frac{\text{Synchronous speed}}{120} \times \text{Number of poles}$$

- To use this function, set the motor constants of the motor in use according to *6-3-2 Motor Parameter Settings* on page 6-17.
- Motor magnetic flux is controlled according to the instructed torque by setting “1: Enable” in Magnetic Flux Weakening Control Function Selection (d82). When the instructed torque is small, motor magnetic flux is weakened and stability of control is improved with Magnetic Flux Weakening Lower Limit (d83) as the lower limit.
- Set the magnetic flux weakening lower limit value in % units in Magnetic Flux Weakening Lower Limit (d83). If the lower limit value is set to too low, there is the risk of the problems of hunting and speed delay.

Use the lower limit value at its factory default (40%) as far as feasibly possible.

Parameter No.	Function name	Data	Default data	Unit
F42	1st Drive Control Selection/	0 : IM V/f control 1 : IM Dynamic torque vector control 5 : IM Vector control without speed sensor	0	-
A14	2nd Drive Control Selection 6-3-1 <i>Sensorless Vector Control Parameter Settings</i> on page 6-16	0: IM V/f control 1: IM Dynamic torque vector control without speed sensor 5: IM Vector control without speed sensor		
P02/A16	1st Motor Capacity/2nd Motor Capacity	0.01 to 1000 kW	Dependent on capacity	kW
P01/A05	1st Motor Pole Number/2nd Manual Torque Boost Voltage	2 to 128 poles	4	Pole
P03/A17	1st Motor Rated Current/2nd Motor Rated Current	0.00 to 500.0 A	21	A
P06/A20	1st Motor Armature Resistance/2nd Motor Armature Resistance	0.00 to 500.0 A	10.55	A
F04/A02	1st Base Frequency/2nd Base Frequency	5.0 to 590.0	50.0	Hz
F05/A03	1st Rated Voltage at Base Frequency/2nd Rated Voltage at Base Frequency	80 to 240 V: AVR operation (200 V class series) 160 to 500 V: AVR operation (400 V class series)	200	V
d82	Magnetic Flux Weakening Control Function Selection	0: Disable 1: Enable	0	-
d83	Magnetic Flux Weakening Lower Limit	10 to 70%	40	%

\*1. To enable switching to the 1st and 2nd control, allocate "12: SET (2nd control)" to either of input terminal [DI1] to [DI7].

## 6-3-2 Motor Parameter Settings

- Ordinarily, offline auto-tuning is performed to set motor parameters. However, if offline auto-tuning ends in error, for example, when the inverter does not reach 50% of its rated current during auto-tuning, set the motor parameters manually.
- To increase the performance of vector control, set each parameter value again according to the motor in use.
- Obtain the motor's datasheet from the motor manufacturer and set each motor parameter. For the following set values, set the data for one phase in a Y-connection after conversion in 1st Base Frequency (F04)/2nd Base Frequency (A02),

1st Motor Armature Resistance (P06)/2nd Motor Armature Resistance (A20) : Set the no-load current of the motor, or set the current value measured when the motor is in isolated no-load operation in 1st Base Frequency (F04)/2nd Base Frequency (A02).

1st Motor Parameter %R1 (P07)/2nd Motor Motor Constant %R1 (A21) : Set the wiring resistance value on the primary side of the motor for one phase in a Y-connection as a percentage Ohmic drop. Calculate by the following formula.

$$\%R1 = \frac{R1 + \text{Cable } R1}{V/(\sqrt{3} \times I)} \times 100 (\%)$$

R1: Motor primary resistance ( $\Omega$ )

Cable R1: Resistance value c of output side cable

V: Motor rated voltage (V)

I: Motor rated current (A)

1st Motor Parameter %X (P08)/2nd Motor Motor Constant %X (A22) : Set the leakage inductance for one phase in a Y-connection motor as a percentage reactance drop. Calculate by the following formula.

$$\%X = \frac{X1 + X2 \times XM/(X2+XM) + \text{Cable } X}{V/(\sqrt{3} \times I)} \times 100 (\%)$$

X1: Motor primary leakage reactance ( $\Omega$ )

X2: Motor secondary leakage reactance (primary converted value)

XM: Motor excitation reactance ( $\Omega$ )

Cable X: Reactance of output side cable ( $\Omega$ )

V: Motor rated voltage (V)

I: Motor rated current (A)

1st Rated Slip Frequency (P12)/2nd Rated Slip Frequency (A26) : Set the rated slip frequency in a Y-connection motor as Hz.

- After setting each motor parameter, adjust the parameters according to *6-3-3 Adjustments for Sensorless Vector Control* on page 6-18.
- To increase response, increase the setting of Speed Control 1 P Proportional Gain (d03)/Speed Control 2 P Proportional Gain (A45), and decrease the setting if motor hunting occurs.

Parameter No.	Function name	Data	Default data	Unit
P06/A20	1st Motor Armature Resistance/2nd Motor Armature Resistance	0.00 to 500.0 A	10.55	A
P07/A21	1st Motor Parameter %R1/2nd Motor Motor Constant %R1	0.00 to 50.00 %	3.17	%
P08/A22	1st Motor Parameter %X/2nd Motor Motor Constant %X	0.00 to 50.00 %	11.47	%
P12/A26	1st Rated Slip Frequency/2nd Rated Slip Frequency	0.00 to 15.00 Hz	1.00	Hz

### 6-3-3 Adjustments for Sensorless Vector Control

- To use sensorless vector control, perform offline auto-tuning.  
If offline auto-tuning cannot be performed, set the parameters of the motor in use according to *6-3-2 Motor Parameter Settings* on page 6-17.



- The inverter may not provide sufficient performance characteristics if the motor is two or more sizes smaller than the maximum applicable motor capacity. This is because the inverter requires a current accuracy of at least 50% of the rated current.
- If sensorless vector control does not provide the intended performance characteristics, adjust the motor parameters depending on the phenomenon, as shown in the following table.

Operation status	Phenomenon	Description of adjustment	Adjustment item
Power running	Actual motor speed is lower than target speed.	Increase the slip compensation gain (drive) or rated slip gradually.	P09/A23 P12/A26
	Actual motor speed is higher than target speed.		
Regeneration	Torque is insufficient at low frequencies (a few Hz).	Increase %R1 and no-load current gradually.	P07/A21 P06/A20
During startup	Shock occurs during startup.	Adjust the speed control P gain.	d03/A45
	Motor rotates momentarily in opposite direction to instructed rotational direction.	Set rotational direction limitation.	H08
At deceleration	Motor is hunting.	Adjust the speed control P gain.	d03/A45
During torque limit	Torque becomes insufficient at low frequencies when torque limit is enabled.	Decrease the torque limit.	F40 F41 E16 E17
Low frequency operation	Rotation is unstable.	Adjust the speed control P gain.	d03/A45

## Output Torque Monitor Function

This function monitors the output torque value.

To monitor the output torque value on the Digital Operator, either set Operator Display Selection during Run (E43) to "8: Calculated torque," or monitor in monitor mode 3\_04.

When monitoring by a signal on the control terminal block, refer to *7-3-5 Analog Output Function Selection* on page 7-46.

Parameter No.	Function name	Data	Default data	Unit
E43	Operator Display Selection during Run	8: Calculated torque	0	-
F31	Output Terminal [AO] Function Selection	4: Output torque 29: Output torque (Bipolar)	0	-

## 6-4 PM Motor Mode

The 3G3M1 Series provides the PM motor mode.

Synchronous motors (PM motors) that are more efficient than induction motors (IM motors) can be controlled.

This section describes the PM motor mode.

### 6-4-1 PM Motor and PM Motor Control

#### PM Motor

A PM motor (abbreviation for “Permanent Magnet motor”) is a motor that uses permanent magnets for the motor rotor.

Generally, it is also called a synchronous motor. Compared with induction motors that are used conventionally for the inverter, PM motors allow no current flow on the rotor side, which results in highly efficient operation due to reduced loss.

In terms of the internal construction, there are various types of PM motors: IPM motors (interior permanent magnet type), SPM motors (surface permanent magnet type), and so on.

PM motors have the control characteristics as shown below.

When using the PM motor mode of the 3G3M1 Series Inverter, understand the following characteristics before selecting the inverter type and function settings.

- The applied AC power must be synchronized with the rotor permanent magnets.  
Although the motor allows a large current to flow, it cannot output a sufficient torque if the AC power is not synchronized.
- The permanent magnets used for the rotor are subject to demagnetization if a large current flows in the PM motor.  
Once a rotor is demagnetized, the motor cannot output a sufficient torque and must be replaced.

#### PM Motor Control

PM motor control with speed feedback can be selected on the 3G3M1 Series.

As large startup torque cannot be output, PM motor control without speed feedback is suitable for applications with reduced torque characteristics (which do not require torque at low speeds) such as fans and pumps.

For applications with constant torque characteristics such as general transfer equipment and elevating axes (which require a torque exceeding the rated torque also at low speeds), select PM motor control with speed feedback.

In PM motor control without speed feedback, use control with startup torque at 50% or less of the motor rated torque to keep the PM motor in a synchronized state.

Follow the steps below to use PM motor control.

1. Switch to the PM motor mode (*6-4-2 Switching to PM Motor Mode* on page 6-21)
2. Execute offline auto-tuning for PM motor parameters (*6-8-1 Motor Off-line Auto-tuning* on page 6-65)
3. Set PM motor parameters (*6-3-2 Motor Parameter Settings* on page 6-17)

Refer to this section if offline auto-tuning fails.

- Adjust the PM motor mode (6-4-4 Adjustment of PM Motor Mode Settings on page 6-22)

## Parameters with Changed Default Data

Changing the control method switches the default data for the following parameters.

Parameter No.	Function name	F42 set value	
		Changed from 15, 16 to other than 15, 16	Changed from other than 15, 16 to 15, 16
F03	1st Maximum Output Frequency	60	90
F04	1st Base Frequency	50	90
F05	1st Rated Voltage at Base Frequency	200/400	Individual capacity values for PMSM
F06	1st Rated Voltage at Maximum Output Frequency	200/400	Individual capacity values for PMSM
F11	1st Motor Electronic Thermal Level	Individual capacity values for IM	Individual capacity values for PMSM
F12	1st Motor Electronic Thermal Time Constant	5 minutes	Less than 18.5 kW: 2 minutes 18.5 kW or more: 5 minutes
F15	1st Frequency Upper Limit	70	90
F23	1st Starting Frequency	0.5	1
F26	Carrier Frequency	2	4
E50	1st Frequency Conversion Coefficient	30	20
P01	1st Motor Pole Number	4	6
P03	1st Motor Rated Current	Individual capacity values for IM	Individual capacity values for PMSM
d01	Speed Control 1 Speed Command Filter	0.02	0.2
d02	Speed Control 1 Speed Detection Filter	0.005	0.025
d03	Speed Control 1 P Proportional Gain	10	2
d04	Speed Control 1 I Integral Time	0.1	0.6
d06	Speed Control 1 Output Filter	0.002	0

Parameter No.	Function name	F42 set value	
		Changed from 15 to other than 15	Changed from other than 15 to 15
d67	Motor Starting Mode Auto Search in Speed Sensor Vector Control	1	2

### 6-4-2 Switching to PM Motor Mode

To switch to the PM motor control mode, set “15: PM Vector control without speed and pole position sensor” or “16: PM Vector control with speed and pole position sensor” to 1st Drive Control Selection (F42), and switch to the PM motor mode.

The PM motor can be connected only in drive control selection 1.

Parameter No.	Function name	Data	Default data	Unit
F42	1st Drive Control Selection	15 : PM Vector control without speed and pole position sensor 16 : PM Vector control with speed and pole position sensor	0	-

### 6-4-3 Offline Auto-tuning for PM Motor Parameters

For details on auto-tuning a PM motor, refer to *6-8-1 Motor Off-line Auto-tuning* on page 6-65.

### 6-4-4 Adjustment of PM Motor Mode Settings

#### PM Motor Adjustment Parameters

For the adjustment of PM motor control, this inverter provides parameters for the control method during startup, parameters for stableness and responsiveness, and initial pole position estimation functions. The following table summarizes the parameters.

For details on how to adjust these parameters, refer to the next section onwards.

Parameter No.	Function name	Data	Default data	Unit
F24	1st Starting Frequency 1 Holding Time	0.00 to 10.00	0.00	s
F26	Carrier Frequency	0: 0.75 kHz 1 to 16	2	kHz
d03	Speed Control 1 P Proportional Gain	0.1 to 200.0	10.0	time
d04	Speed Control 1 I Integral Time	0.001 to 9.999 999: Cancel integral term	0.100	s
P30	1st PM Motor Starting Method	0: Pull-in by current 1: For IPM type 1 (Interior permanent magnet synchronous motor) 2: For SPM type (Surface permanent magnet synchronous motor) 3: Pull-in by current for IPM type 4: For IPM type 2 (Interior permanent magnet synchronous motor)	1	-
P61	1st PM Motor d-axis Inductance	0.00 to 500.00	4.77	mH
P62	1st PM Motor q-axis Inductance	0.00 to 500.00	10.70	mH
P74	1st PM Motor Reference Current at Starting	10 to 200 (Based on the rated current of the motor)	80	%
{P89}	{P89Motor 1 (PM motor control switching level)}	0 to 100	0	%

## PM Motor Adjustment

Adjust the PM motor as shown in the table below depending on its operation status and the phenomenon.

Operation status	Phenomenon	Description of adjustment	Adjustment item
During startup	Motor rotates in reverse or rotates slightly.	The motor may rotate slightly in magnetic pole alignment during startup. Set 1st PM Motor Starting Method P30 to 1 to suppress the rotation amount during startup. When operation is performed with P30 set to 0 or 3, reverse rotation becomes difficult by lowering P74.	P30 P74
	Motor stalls or causes an overcurrent trip.	If the motor stalls during startup, a large current may flow, which causes an overcurrent trip. Increase the PM motor starting current value. Increasing the PM motor starting current value improves the magnetic pole alignment during startup, which results in an increase in the startup torque. However, setting this parameter to an excessively large value may cause detection of an overload. Check the value in the monitor of electronic thermal overload protection for motor (monitor mode: 5_62).	P74
		Increase the PM motor starting time value. This increases the time during which the starting current flows to improve magnetic pole alignment during startup, which results in an increase in the startup torque.	F24
	Motor starting time is too long.	Set P30 correctly according to the motor in use.	P30
Motor rotating	Rotation is unstable.	If the motor rotation is unstable during startup, increase the motor starting current. However, setting this parameter to an excessively large value may cause detection of an overload. Check the value in the monitor of electronic thermal overload protection for motor (monitor mode: 5_62).	P74
	A shock or overcurrent trip occurs.	Adjust the speed control gain to a larger value and the integral time to a smaller value.	d03, d04
	Motor is hunting or vibrating.	Adjust the speed control gain to a smaller value and the integral time to a larger value.	d03, d04
Increase the carrier frequency if it is low.		F26	
	Gradually increase the PM motor d-axis inductance.	P61	
	Gradually increase the PM motor q-axis inductance.	P62	

## Overcurrent Protection

PM motors must be set with an allowable current value for preventing the permanent magnet from becoming demagnetized. If a current exceeding this allowable current value is allowed to pass, the magnetic force of the permanent magnet weakens and the desired motor characteristics can no longer be obtained.

When a current of current value set in 1st PM Motor Overcurrent Protection Level (P90) or higher flows, overcurrent protection alarms OC1, OC2 or OC3 are output to protect the motor.

Parameter No.	Function name	Data	Default data	Unit
P90	1st PM Motor Overcurrent Protection Level	0.00 to 4000 A (0.00: No active)	50.00	A

## High-efficiency Control

In the operation of PM motors, motor parameters are used to perform high-efficiency control. Operation of a PM motor with the motor parameters unknown or in a state where rotation tuning cannot be performed is sometimes possible by disabling high-efficiency control.

To disable high-efficiency control, set PM Motor High-efficiency Control Selection (d89) to 0.

Parameter No.	Function name	Data	Default data	Unit
d89	PM Motor High-efficiency Control Selection	0: Disable 1: Enable	1	-

## Magnetic Position Detection Completed Signal (PTD)

The ON signal is output when the magnetic pole position is detected at PM motor startup. This parameter is enabled when P30 is set to other than 0.

Parameter No.	Function name	Data	Default data	Unit
E20, E21, E27	Output Terminal [DO1] Function Selection, Output Terminal [DO2] Function Selection, Output Terminal [ROA, ROB] Function Selection	89: PTD (magnetic position detection completed signal)	-	-

## Synchronous Motor Magnetic Pole Position Pull-in Frequency

When using an encoder having A, B and Z phase outputs in PM Vector control with speed and pole position sensor, pull-in operation at the magnetic pole position is performed at the frequency set at d80 during the period up to detection of the Z phase immediately after power is turned ON as the magnetic pole position is unknown. After detection of the Z phase, the magnetic pole position referenced to the magnetic pole position sensor offset set to P95 is established, and regular operation is switched to. Generally, there is no need for adjustment.

Parameter No.	Function name	Data	Default data	Unit
d80	1st PM Motor Magnetic Pole Position Pull-in Frequency	0.1 to 10.0	1.0	Hz

## 6-5 Speed Control

The 3G3M1 Series is provided with speed control.

This section describes the speed control settings and functions.

### 6-5-1 Speed Control Settings

Speed control parameters can be selected from four types by combining speed control signals. Speed control is enabled in vector control with speed sensor, V/f control with speed sensor and vector control without speed sensor (permanent magnet synchronous motor). Speed control parameters can be adjusted to perform optimum speed control.

Parameter No.	Function name	Data	Default data	Unit
d01/A43/b43/r 43	Speed Control 1 Speed Command Filter/Speed Control 2 Speed Command Filter/Speed Control 3 Speed Command Filter/Speed Control 4 Speed Command Filter	0.000 to 5.000	0.02	s
d02/A44/b44/r 44	Speed Control 1 Speed Detection Filter/Speed Control 2 Speed Detection Filter/Speed Control 3 Speed Detection Filter/Speed Control 4 Speed Detection Filter	0.000 to 0.100	0.005	s
d03/A45/b45/r 45	Speed Control 1 P Proportional Gain/Speed Control 2 P Proportional Gain/Speed Control 3 P Proportional Gain/Speed Control 4 P Proportional Gain	0.1 to 200.0	10	-
d04/A46/b46/r 46	Speed Control 1 I Integral Time/Speed Control 2 I Integral Time/Speed Control 3 I Integral Time/Speed Control 4 I Integral Time	0.001 to 9.999 999: Cancel integral term	0.1	s
d05/A47/b47/r 47	Speed Control 1 FF Gain/Speed Control 2 FF Gain/Speed Control 3 FF Gain/Speed Control 4 FF Gain	0.00 to 99.99	0	s
d06/A48/b48/r 48	Speed Control 1 Output Filter/Speed Control 2 Output Filter/Speed Control 3 Output Filter/Speed Control 4 Output Filter	0.000 to 0.100	0.002	s



Parameter No.	Function name	Data	Default data	Unit
d07/A49/b49/r49	Speed Control 1 Notch Filter Resonance Frequency/Speed Control 2 Notch Filter Resonance Frequency/Speed Control 3 Notch Filter Resonance Frequency/Speed Control 4 Notch Filter Resonance Frequency	1 to 500	200	Hz
d08/A50/b50/r50	Speed Control 1 Notch Filter Attenuation Level/Speed Control 2 Notch Filter Attenuation Level/Speed Control 3 Notch Filter Attenuation Level/Speed Control 4 Notch Filter Attenuation Level	0 to 40	0	dB
E01 to E05, E98, E99	Input Terminal [DI1] Function Selection to Input Terminal [DI7] Function Selection	78: Speed control parameter selection 1 79: Speed control parameter selection 2	-	-

## Switching Speed Control Constants

In readiness for cases where speed control constants must be changed according to changes in load or machine conditions, the 3G3M1 has four speed control constants. These can be switched by speed control parameter selection 1 terminal input "MPRM1" and speed control parameter selection 2 "MPRM2." Speed control constants 1 and 2 can also be switched by the "SET (2nd control)" terminal.

Input signal		Switching speed control constants
MPRM2	MPRM1	
OFF	OFF	Speed control constant 1: d01 to d08
OFF	ON	Speed control constant 2: A43 to A50
ON	OFF	Speed control constant 3: b43 to b50
ON	ON	Speed control constant 4: r43 to r50

Input signal SET	Switching speed control constants
OFF	Speed control constant 1: d01 to d08
ON	Speed control constant 2: A43 to A50

## Speed Command Filter (d01/A43/b43/r43)

This parameter is for setting the time constant of the primary lag filter for the speed set value. Adjust this parameter, for example, when overshooting in response to changes in the speed command is large.

Setting a large filter time constant stabilizes the output and reduces overshoot in response to changes in the speed setting though the speed response becomes slower.

## Speed Detection Filter (d02/A44/b44/r44)

This parameter is for setting the time constant of the primary lag filter with respect to the speed detection value. This is a filter for feedback. Set it when the mechanical system vibrates.

Adjust this parameter, for example, when ripple (vibration component) is carried on the speed detection signal as a result of the control target (mechanical system) such as belt deflection, and hunting caused by that vibration component prevents gain, etc. of the PI controller from being sufficiently increased (response is slow). Also, set this parameter when there are few pulses from the encoder which results in a speed that causes vibration.

When the filter time constant is increased, the speed detection value is stabilized, and the gain of the PI controller can be increased even if ripple is carried on the speed detection signal. Note, however, that as speed detection itself is delayed, speed response slows down, overshooting increases and sometimes results in hunting.

## P (Gain) (d03/A45/b45/r45), I (Integral Time) (d04/A46/b46/r46)

These parameters are for setting the gain and integral time of the speed controller (ASR).

By setting d04 = 999, the integral operation can be disabled.

- P (gain)

Definition of P gain = 1.0 is a torque command of 100% (100% torque output at each capacity) when the speed deviation (speed command - actual speed) is 100% (equivalent to the maximum speed setting).

Adjust the P gain according to the moment of inertia of the machine connected to the motor shaft. When the moment of inertia increases, P gain also must be increased to ensure the same response. When P gain is increased, control response becomes faster, however, the motor speed sometimes overshoots and the motor hunts. Also, machine resonance and excessive noise amplitude causes the machine or motor to generate abnormal noise.

If this happens, the resonance amplitude can be decreased by lowering P gain. However, excessively decreasing P gain causes control response to slow down, low-frequency speed fluctuations to occur, and stabilization of the motor speed to take longer.

- I (integral time)

When the integral time is set to a small value, response is fast as the correction time for deviation is short. To allow overshooting to enable the target speed to be reached quickly, decrease the set value, and when overshooting cannot be allowed, increase the set value.

In cases where machine resonance occurs and abnormal machine noise is emitted from the motor and gears, the resonance point can be moved to the low frequency side to suppress resonance in the high frequency region by increasing the integral time.

## FF (Gain) (d05/A47/b47/r47)

This parameter performs feedforward control for adding the torque that is determined from the amount of change in the speed command directly to the torque command.

PI control of the speed controller is feedback control whereby corrective action (following the speed command) is performed according to the result (actual speed value) of the control target. Accordingly, with this control, correction also is effective on external disturbances that cannot be measured and causes that cannot be directly measured such as the uncertainty of control target characteristics.

However, changes also in known command amounts are corrected after they appear in deviation (speed command - actual speed value) later on. As the control value (torque command) is required in advance for known causes, faster-response control can be expected by adding that control value directly to the torque command. This parameter is for performing this kind of control. Feedforward control adds the torque that is determined from the amount of change in the speed command directly to the torque command.

This is effective when the load inertia is already known. As shown conceptually in the figure below, the speed of the actual value following the command amount when feedforward control is disabled and when it is enabled is completely different. Note, however, that, in order to obtain maximum effect, the PI constants of feedback control should be adjusted to balance well with this set value.

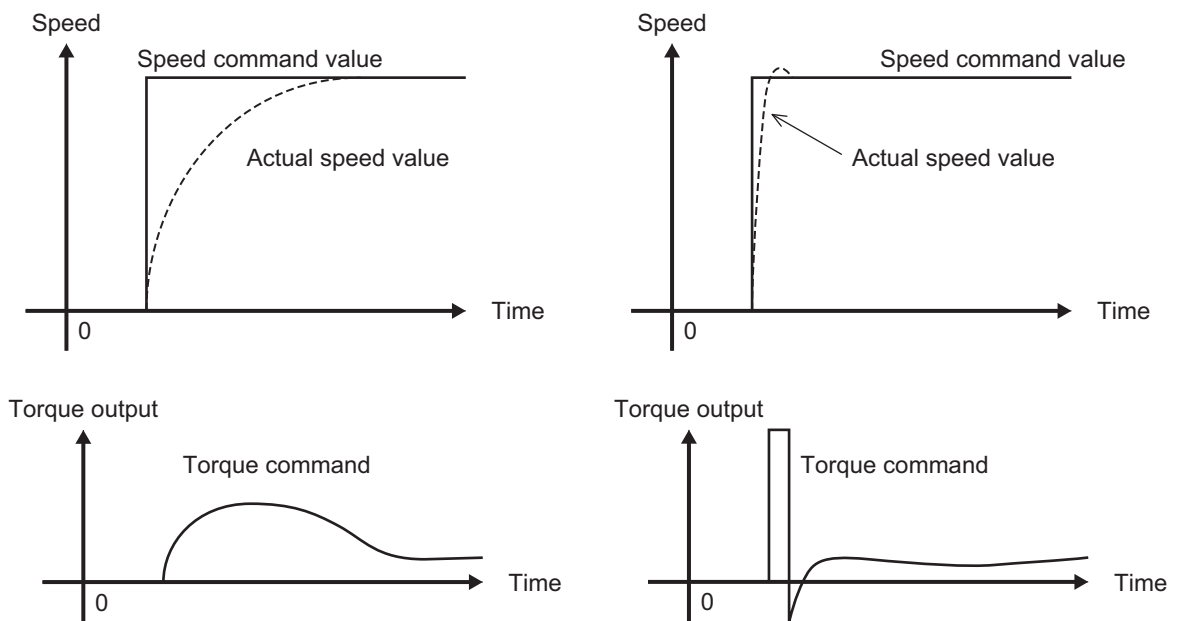

Although the above effect can be obtained by setting the P gain of the speed controller to a higher value, increasing gain is counterproductive as is it also increases system response and produces machine resonance and vibration sound.

### Notch Filter Resonance Frequency (d07/A49/b49/r49) and Notch Filter Attenuation Level (d08/A50/b50/r50)

The speed loop gain at only near a preset resonance point can be lowered to suppress machine resonance. The notch filter can be used only when “vector control with speed sensor” is selected. Setting a higher speed loop gain to increase speed response may result in machine resonance being generated.

To suppress machine resonance, the speed loop gain must be lowered to lower the overall speed response. If the notch filter is used at this time, the speed loop gain at only near the preset resonance point can be lowered, and the speed loop gain at other than the resonance point can be set higher. As a result, the overall speed response can be increased.

When “0” (dB) is set to “attenuation level,” the notch filter is disabled.

## Speed Control Speed Loop Switching Time at Parameter Change (d25)

Parameters can be switched even when the inverter is operating. The parameters that can be switched include the P gain and I integral time of the speed control system. When these parameters are switched while the inverter is operating, in some load operating conditions, sudden torque fluctuations may occur and cause mechanical shock which may be problematic.

To alleviate this kind of shock, suppress sudden fluctuations in torque by setting the ramp function in Speed Control Speed Loop Switching Time at Parameter Change (d25) when switching parameters.

Parameter No.	Function name	Data	Default data	Unit
d25	Speed Control Speed Loop Switching Time at Parameter Change	0.000 to 1.000	0.000	s

## 6-6 Torque Control

The 3G3M1 Series provides the torque control mode.

This section describes the torque control settings and functions.

### 6-6-1 Torque Control Settings

The inverter provides torque control that controls the output torque of the motor.

- This function is enabled when “5: IM Vector control without speed sensor,” “6: IM Vector control with speed sensor” and “16: PM Vector control with speed and pole position sensor” are set in 1st Drive Control Selection (F42)/2nd Drive Control Selection (A14).
- Torque control can be switched between enabled and disabled by the setting of parameter H18. Torque control can be switched to speed control by turning “23: ATR (torque control cancel)” allocated to Input Terminal [DI1] Function Selection to Input Terminal [DI7] Function Selection (E01 to E05, E98, E99) to ON with the torque reference enabled.
- Select torque command input in Torque Reference Selection (H332). One of Torque Reference (H333), analog input, and communication can be selected.

When instructing the torque command by analog input, torque becomes 0% to 200% at 0 to 10 V (4 to 20 mA).

- Because, under torque control, the speed of the inverter is determined by the balance between torque and load, to prevent the inverter from going out of control, set the speed limit/acceleration level as a percentage of the maximum frequency in d32 (for forward rotation) and d33 (for reverse rotation).
- The torque command value of this torque control function takes the motor rated torque to be 100%.
- When “4: B/D (torque polarity detection)” is allocated to a multifunction output terminal, the signal for distinguishing drive torque or braking torque is output. The OFF signal is output when the torque is drive torque, and the ON signal is output when the torque is braking torque.

Parameter No.	Function name	Data	Default data	Unit
H18	Torque Control Operate Selection	0: Disable (Speed control) 2: Torque current command input 3: Torque command input	0	-
H332	Torque Reference Selection	0: Analog input 2: Operator (H333) 4: RS-485 communication 5: Fieldbus (Reserved)	0	-
H333	Torque Reference	0 to 200 %	0	%
E01 to E05, E98, E99	Input Terminal [DI1] Function Selection to Input Terminal [DI7] Function Selection	23: ATR (torque control cancel)	-	-
E20, E21, E27	Output Terminal [DO1] Function Selection, Output Terminal [DO2] Function Selection, Output Terminal [ROA, ROB] Function Selection	4: B/D (torque polarity detection)	-	-

Parameter No.	Function name	Data	Default data	Unit
E61	Input Terminal [AI1] Function Selection	10: Torque command 11: Torque current command	-	-
E62	Input Terminal [AI2] Function Selection (AII)			
E63	Input Terminal [AI2] Function Selection (AIV)			
y99	Support Tool Link Function Selection	0: Numerical setting and terminal command (including operation command ) by related parameter settings 1: Numerical setting uses communications command (support tools) 2: Terminal setting uses communications command (support tools) 3: Both numerical setting and terminal command use communications command (support tools)  Numerical setting means Frequency reference, torque command, or torque bias command.	0.00	%
S02	Torque Reference	-327.68 to 327.67 <sup>*1</sup>	0.00	%
S03	Torque Current Command	-327.68 to 327.67 <sup>*1</sup>	0.00	%
S22	Torque Reference via Communication	-327 to 327 <sup>*1</sup>	0	%
S23	Torque Current Command via Communication	-327 to 327 <sup>*1</sup>	0	%

\*1. The upper and lower limits of the torque command via communications are  $\pm 200.00\%$ . When the command contains a value exceeding the  $\pm 200.00\%$  range, the torque command is limited internally to  $\pm 200.00\%$ .

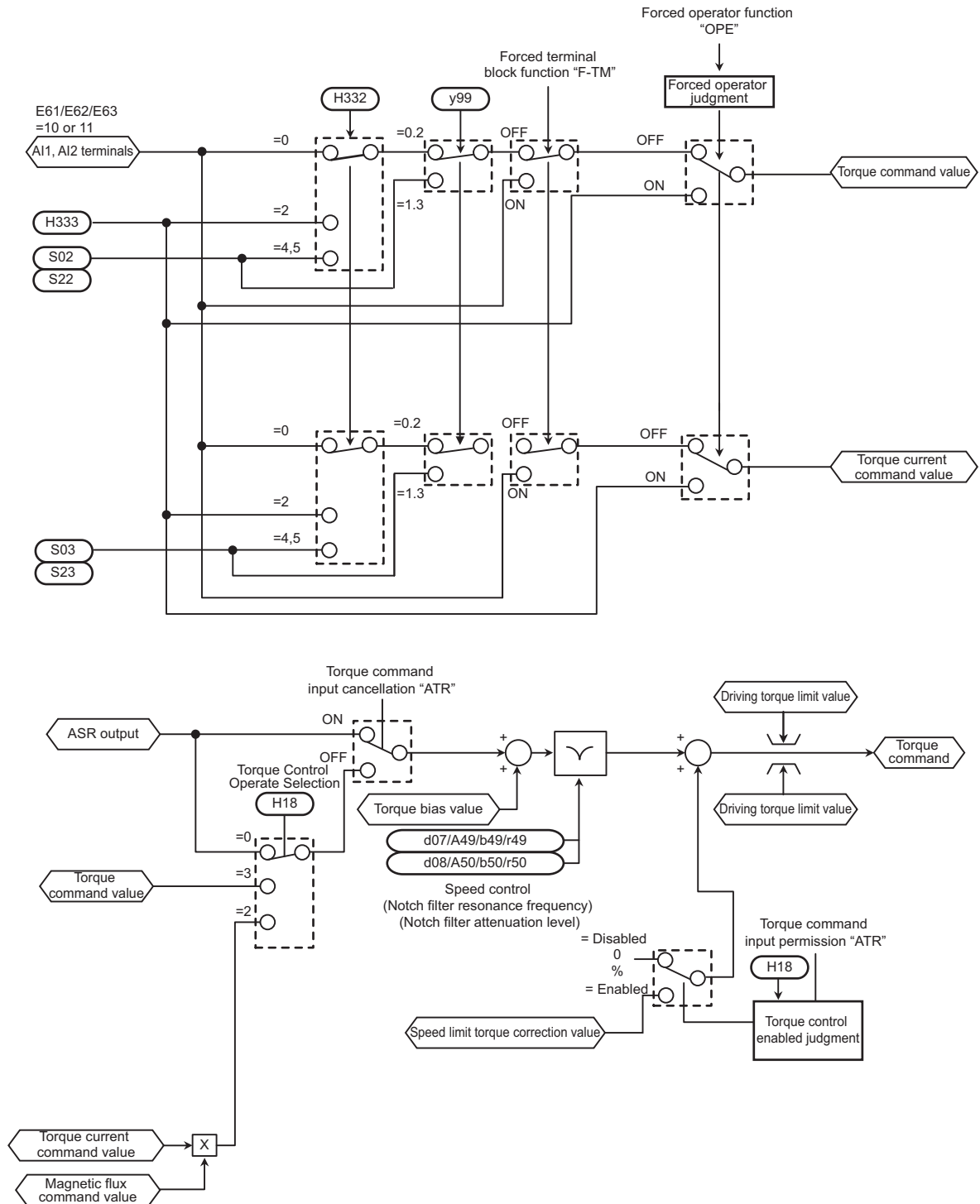

## 6-6-2 Torque Bias Function Settings

This function is for applying bias to the torque command in torque control.

- This function is enabled when "5: IM Vector control without speed sensor," "6: IM Vector control with speed sensor" and "16: PM Vector control with speed and pole position sensor" are set in 1st Drive Control Selection (F42)/2nd Drive Control Selection (A14).
- Select the command source of torque bias in Torque Bias Function Selection (H154).  
 "0: Torque bias invalid"  
 Disables torque bias.

#### “1: Torque bias (Level 1 to 3)”

Switches the torque bias level according to “TB1” and “TB2” allocated to multifunction input terminals.

Input signal		Torque bias value selection
TB1	TB2	
OFF	OFF	No torque bias
OFF	ON	H155: Torque bias level 1
ON	OFF	H156: Torque bias level 2
ON	ON	H157: Torque bias level 3

#### “2: Analog torque bias”

Set one of Input Terminal [AI1] Function Selection (E61), Input Terminal [AI2] Function Selection (AII) (E62) or Input Terminal [AI2] Function Selection (AIV) (E63) to “9c torque bias,” and determine the torque bias value by analog current input or analog voltage input.

When “62: H-TB (Torque bias hold)” is allocated to Input Terminal [DI1] Function Selection to Input Terminal [DI7] Function Selection (E01 to E05, E98, E99) and the terminal is turned ON, the torque bias level currently entered to that input is held.

#### “4: Modbus communication”

Set Torque Bias Value via Communication (S15)/Torque Bias Value (S24) via Modbus communication.

- The torque command value of this torque control function takes the motor rated torque to be 100%.
- Set the polarity of the instructed torque bias value in Torque Bias Polarity Selection (H334).

#### “0: Signed”

The forward torque increases when the torque bias value is positive (+) and the reverse torque increases when the torque bias value is negative (-), independent of the operation direction.

#### “1: Depends on the run direction”

The direction in which torque bias works depends on the RUN command direction.

Forward command	:	Forward torque increases when torque bias value is positive (+). Reverse torque increases when torque bias value is negative (-).
Reverse command	:	Reverse torque increases when torque bias value is positive (+). Forward torque increases when torque bias value is negative (-).

- Set Torque Bias Mechanical Loss Compensation (H158) to compensate for mechanical loss.
- Shock is sometimes large when the torque bias is simply added. Startup with little shock is possible by setting a timer in Torque Bias Startup Timer (H159). Set the timer as the time for adding 100% torque. When 0 is set, all the torque bias value is added instantaneously.
- Torque bias can be gradually excluded in the same way as the startup timer by setting Torque Bias Shutdown Timer (H161). Set the timer as the time for subtracting 100% torque. When 0 is set, all the torque bias value is subtracted.
- The maximum torque bias value can be limited by setting Torque Bias Limit (H162).



Parameter No.	Function name	Data	Default data	Unit
H154	Torque Bias Function Selection	0: Invalid 1: Operator (H155 to H157) 2: Analog input 4: RS-485 communication 5: Fieldbus (Reserved)	0	-
H155/ H156/ H157	Torque Bias Level 1 Torque Bias Level 2 Torque Bias Level 3	-300 to +300 %	0	%
H158	Torque Bias Mechanical Loss Compensation	0 to 300	0	%
H159	Torque Bias Startup Timer	0.00 to 1.00	0.00	s
H161	Torque Bias Shutdown Timer	0.00 to 1.00	0.00	s
H162	Torque Bias Limit	0 to 300	200	%
H334	Torque Bias Polarity Selection	0: Signed 1: Depends on the run direction	0	-
S15	Torque Bias Value via Communication	-327.68 to 327.67	0.00	%
S24	Torque Bias Value (MX2 compatible)	-327 to +327 (Truncate to S15 set value)	0	%
E01 to E05, E98, E99	Input Terminal [D11] Function Selection to Input Terminal [D17] Function Selection	60: TB1 (Torque bias command 1) 61: TB2 (Torque bias command 2) 62: H-TB (Torque bias hold)	-	-

## 6-7 Position Control

On the 3G3M1 Series, the PG feedback signal can be used to perform position control.

The pulses of the feedback signal are counted internally by the inverter, and operation is performed so that moving amount is to the specified position data.

In vector control with speed sensor or V/f control with speed sensor, the speed and position are calculated based on the feedback signal. In vector control without speed sensor or V/f control without speed sensor, only position is calculated based on the feedback signal. The inverter is also mounted with an orientation function as an applied function for position control.

The position control function can be used in 1st and 2nd control. However, note that only one set of position control related parameters is provided for the position control function.

### 6-7-1 Basic Operation

Positioning control is enabled by turning digital input “SPD” OFF during a stop. After that, operation is started by input of the RUN command, acceleration is performed up to the set frequency, and a deceleration and stop are performed so that movement is made up to the position data. When movement stops, the servo lock is activated. Eight types of positioning data can be selected by combinations of “CP1,” “CP2” and “CP3.” Movement is resumed by a change made to the position data (target position changed) by “POS-SET” turning ON. When the target position is reached and the servo lock is activated, digital output “POK” turns ON. If “P-SEL” is turned ON when the mechanical brake is applied during a servo lock, the electric angle is fixed so that the mechanical brake can be input.

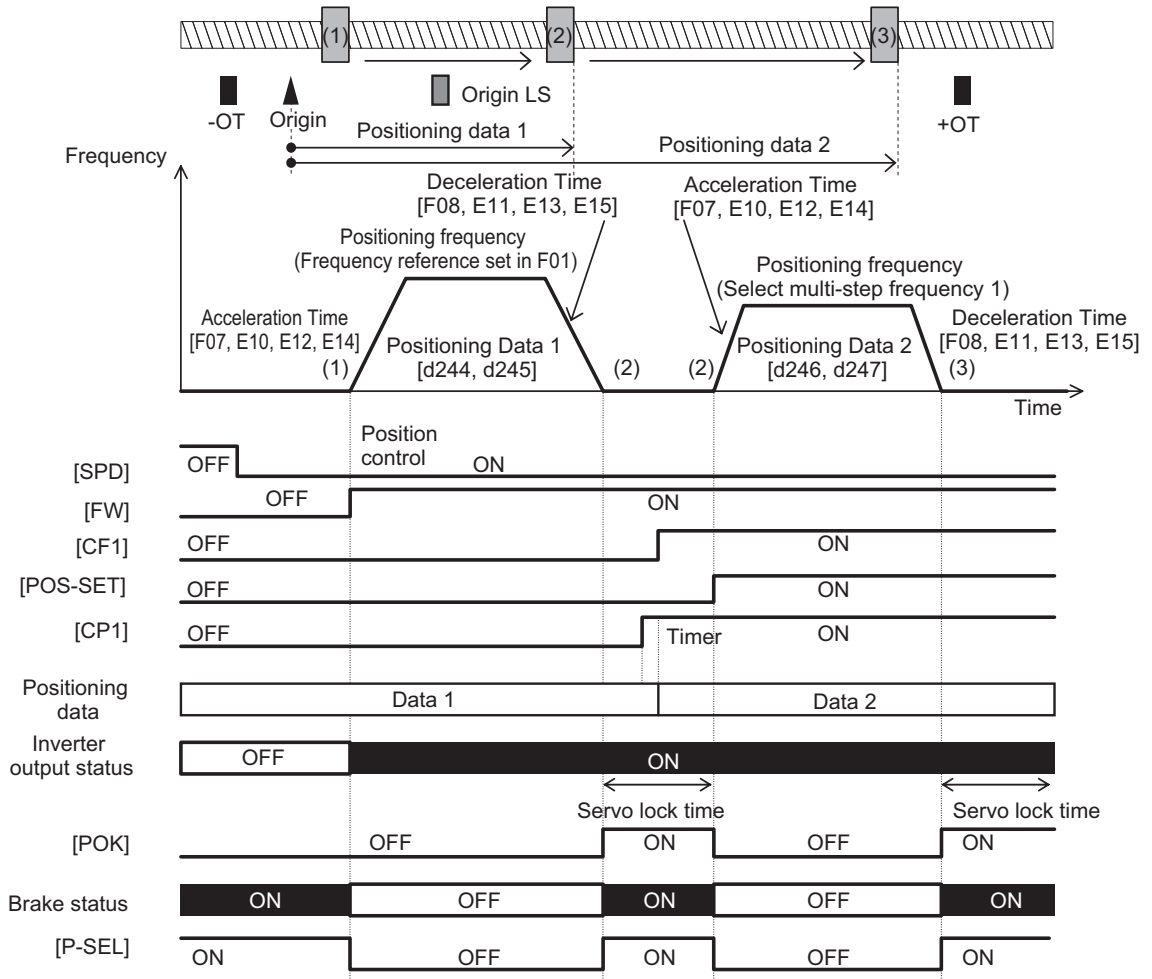

6-7 Position Control

6

6-7-1 Basic Operation

List of input terminal functions		
Data	Terminal function	Description
42	ORL: Origin search limit signal	The return-to-origin operation is as follows: After "ORL" is turned ON during return-to-origin operation, movement is made by the homing offset from the initial Z phase of the PG, and movement is stopped.
119	P-SEL: ASR integral term cancellation	When "P-SEL" is turned ON, the integral term of the speed controller is canceled and P operation is performed. When the mechanical brake is applied during position control, the motor cannot rotate even if there exists position error. For this reason, the integral term accumulates which sometimes causes an overload trip to occur. In such a case, use this function.
135	INC/ABS: Increment/absolute position switching	When "INC/ABS" turns ON, the positioning data is taken as the absolute position from the current position. When "INC/ABS" turns OFF, the positioning data is taken as the absolute position from the origin.
136	ORT: Orientation command	Orientation operation is started when "ORT" is turned ON.

List of input terminal functions		
Data	Terminal function	Description
137	SPD: Speed/position switching	The mode changes to the position control mode when "SPD" is turned OFF. The mode changes to the speed control mode when turned ON. This function can be operated during operation. After positioning by position control, the state changes to a servo lock state (in vector control) or to a DC braking state (in V/f control).
138	ORG: Return-to-origin start up signal	The mode changes to the return-to-origin mode when "ORG" is turned ON.
139	FOT: Forward rotation drive prohibited	The overtravel detection signal in the positive direction is input when "FOT" is turned OFF. Use this for emergency stop and return-to-origin.
140	ROT: Reverse rotation driving prohibited	The overtravel detection signal in the negative direction is input when "ROT" is turned OFF. Use this for emergency stop and return-to-origin.
141	PCLR: Current position clear	The current position is cleared to zero when "PCLR" is turned ON.
142	PSET: Current position preset	When "PSET" is turned ON, the current position is taken as Preset Position (MSB) (d240) and Preset Position (LSB) (d241).
144	POS-SET: Position change command	When "POS-SET" is turned ON, the target position is changed, and movement to the new target position is started.
145 146 147	CP1: Position command selection 1 CP2: Position command selection 2 CP3: Position command selection 3	Select Positioning Data 1 to 8 (d244 to d259) as a combination of these.

List of output terminal functions		
Data	Terminal function	Description
82	POK: Positioning completed	This turns ON at completion of positioning (position deviation is Positioning Completed Range (d239) or less).
151	OT-OUT: Overtravel detection	This turns ON when the software overtravel was detected or the overtravel detection signal was accepted.
152	STOP-OUT: Forced stop detection	This turns ON when a forced deceleration stop is made by a multifunction input function "STOP" or detection of an overtravel.

## 6-7-2 Position Control Gain

Position control generates the torque command and speed command to drive the inverter based on the deviation between the current position and command position according to operation patterns that are generated from position data (target position). Basically, position control assumes that speed control has already been adjusted under a real load and that acceleration and deceleration are possible without any problem. Position control gain adjusts the response of position control. To increase response, set larger values in Position Loop Gain 1 (d203) and Position Loop Gain 2 (d204). Setting too large a value causes hunting or overshooting. To switch the gain at low speed and high speed, set the switching frequency in Position Loop Gain Switch Frequency (d205). If the system starts to vibrate

when system rigidity is weak and gain is increased, set a large value in Position Control Feed Forward Gain (d201).

Parameter No.	Function name	Data	Default data	Unit
d201	Position Control Feed Forward Gain	0.00: Cancel 0.01 to 1.50	0.00	-
d202	Position Control Feed Forward Filter	0.000 to 5.000	0.500	s
d203	Position Loop Gain 1 (low speed side)	0.1 to 300.0	1.0	-
d204	Position Loop Gain 2 (high speed side)	0.1 to 300.0	1.0	-
d205	Position Loop Gain Switch Frequency	0.0 to 590.0	0.0	Hz

### 6-7-3 Electronic Gear

With position control, the moving amount is basically managed by the number of pulses of the PG. However, it is more convenient to manage moving amounts referenced to physical numeric values (user values). The conversion ratio of user values to number of PG pulses can be set as an electronic gear.

Parameter No.	Function name	Data	Default data	Unit
d206	Electronic Gear Denominator	1 to 65535	1	-
d207	Electronic Gear Numerator	1 to 65535	1	-

#### ● How to calculate the electronic gear

Electronic gear numerator/electronic gear denominator ratio can be calculated based on the moving amount per user values unit (position resolution) [mm/user preference], moving amount per single rotation of the motor [mm/rev] and number of PG pulses per single rotation of the motor [pulse/rev].

$$\begin{aligned} \frac{\text{Electronic gear numerator}}{\text{Electronic gear denominator}} &= \frac{\text{Moving amount per user value [mm/user value]}}{\text{Moving amount per 1 PG pulse [mm/pulse]}} \\ &= \frac{\text{Moving amount per user value [mm/user value]}}{\frac{\text{Moving amount per motor rotation [mm/rev]}}{\text{Number of pulses per motor rotation [pulse/rev]}}} \end{aligned}$$

Set the electronic gear reduced so that each of the electronic gear numerator/electronic gear denominator reduced become integers of 65535 or less.

Ex- ple) When the moving amount per user values unit is 0.1 [mm/user preference], machine speed at motor speed of 1,800 [r/min] is 150 [m/min] and the number of PG pulses is 1,000 [pulse/rev]

$$\frac{\text{Electronic gear numerator}}{\text{Electronic gear denominator}} = \frac{0.1 \text{ [mm/user value]}}{150 \times 1000 / 1800 \text{ [mm/rev]}} = \frac{180}{150} = \frac{12}{10}$$

### 6-7-4 Acceleration/Deceleration Time Selection

The normal acceleration/deceleration time is selected during position control. Even if the acceleration/deceleration time selection is switched or parameter values are changed during position control operation, the new selection or parameter values are not reflected in operation. These are reflected when the next position control operation is started.

The following table summarizes acceleration/deceleration time selections.

SET terminal	E125 E126	2CH terminal	Output frequency	Forward / reverse	RT2 terminal	RT1 terminal	Acceleration time	Deceleration time
1st control	0: 2CH	OFF	-	-	-	-	F071st Acceleration Time 1	F081st Deceleration Time 1
		ON	-	-	-	-	E121st Acceleration Time 2	E131st Deceleration Time 1
	1: Switch frequency	-	Disable	-	-	-	F071st Acceleration Time 1	F081st Deceleration Time 1
	2: Switching normal/reverse rotation	-	-	Disable	-	-	F071st Acceleration Time 1	F081st Deceleration Time 1
	3: RT1/2	-	-	-	OFF	OFF	F071st Acceleration Time 1	F081st Deceleration Time 1
		-	-	-	OFF	ON	E102nd Acceleration Time 1	E112nd Deceleration Time 1
		-	-	-	ON	OFF	E121st Acceleration Time 2	E131st Deceleration Time 1
		-	-	-	ON	ON	E142nd Acceleration Time 2	E152nd Deceleration Time 2
2nd control	0: 2CH	OFF	-	-	-	-	E102nd Acceleration Time 1	E112nd Deceleration Time 1
		ON	-	-	-	-	E142nd Acceleration Time 2	E152nd Deceleration Time 2
	1: Switch frequency	-	Disable	-	-	-	E102nd Acceleration Time 1	E112nd Deceleration Time 1
	2: Switching normal/reverse rotation	-	-	Disable	-	-	E102nd Acceleration Time 1	E112nd Deceleration Time 1
	3: RT1/2	-	-	-	OFF	OFF	F071st Acceleration Time 1	F081st Deceleration Time 1
		-	-	-	OFF	ON	E102nd Acceleration Time 1	E112nd Deceleration Time 1
		-	-	-	ON	OFF	E121st Acceleration Time 2	E131st Deceleration Time 1
		-	-	-	ON	ON	E142nd Acceleration Time 2	E152nd Deceleration Time 2

Acceleration/deceleration time selection during position control is basically the same as in speed control, with the exception of limits being applied to the following:

- LAC terminal disabled

- The function for switching the acceleration/deceleration time according to the output frequency when “1: Switch frequency” is set to 1st 2-step Acceleration/ Deceleration switching Condition Selection (E125)/2nd 2-step Acceleration/Deceleration Switching Condition Selection (E126) is disabled. Ordinarily, the acceleration/deceleration time is used when the output frequency is the threshold or less.
- The function for switching the acceleration/deceleration time according to the forward rotation/ reverse rotation when “2: Forward/reverse” is set to 1st 2-step Acceleration/ Deceleration switching Condition Selection (E125)/2nd 2-step Acceleration/Deceleration Switching Condition Selection (E126) is disabled. Ordinarily, the acceleration/deceleration time on the forward rotation side is used.

Deceleration Time for Forced Stop (H56) is selected for the acceleration/deceleration time in the following cases:

- When the RUN command (FWD, REV) is shut off and deceleration is performed during position control
- When an emergency stop is performed by detection of an overtravel (OT) or input of the “STOP” signal

### 6-7-5 Positioning Data

Positioning data for up to eight points can be set in user value units. Positioning data is selected in combinations of position command selection signals “CP1” “CP2” and “CP3” via digital input. To prevent chattering at contacts, selection is switched when a position command selection signal has not changed state until the Position Data Determination Time (d238) elapses. Positioning data can be changed during position control. To reflect a newly changed position, turn the position change command “POS-SET” ON. When positioning data is changed during a stop, operation by position change command “POS-SET” is not required.

“CP3”	“CP2”	“CP1”	Parameter	Data	Range (user value unit)
OFF	OFF	OFF	d244, d245	Positioning data 1	±268435455 (F000 0001 hex to 0FFF FFFF hex)
OFF	OFF	ON	d246, d247	Positioning data 2	±268435455
OFF	ON	OFF	d248, d249	Positioning data 3	±268435455
OFF	ON	ON	d250, d251	Positioning data 4	±268435455
ON	OFF	OFF	d252, d253	Positioning data 5	±268435455
ON	OFF	ON	d254, d255	Positioning data 6	±268435455
ON	ON	OFF	d256, d257	Positioning data 7	±268435455
ON	ON	ON	d258, d259	Positioning data 8	±268435455

Parameter No.	Function name	Data	Default data	Unit
E01 to E05 E98 E99	Input Terminal [DI1] Function Selection to Input Terminal [DI7] Function Selection	135 (1135): Increment/absolute position switching "INC/ABS" 144 (1144): Position change command "POS-SET" 145 (1145): Position command selection 1 "CP1" 146 (1146): Position command selection 2 "CP2" 147 (1147): Position command selection 3 "CP3"	-	-
d237	Positioning Data Type	0: Absolute position (ABS) 1: Relative position (INC)	0	-
d238	Position Data Determination Time	0.000 to 0.100 s	0.000	s
d277	Positioning Data Setting Selection via communication	0: Disable Communications Positioning Data (S20, S21) 1: Enable Communications Positioning Data (S20, S21)	0	-
S20	Positioning Data via Communication (MSB)	-268435455 to 268435455 (MSB: -4096 to 4095)	0	-
S21	Positioning Data via Communication (LSB)	(LSB: 0 to 65535)	0	-

### ● Positioning Data Type (d237)

Handling of the positioning data set to positioning data 1 to 8 can be switched between handling as absolute positions or as moving amounts.

To switch handling when necessary, use increment/absolute position switching "INC/ABS" (data = 135) in the multifunction input terminal function.

When "INC/ABS" is allocated to multifunction input terminals, the d237 setting is disabled.

### ● Position Data Determination Time (d238)

When position command selection 1 "CP1" to position command selection 3 "CP3" is switched, chattering may cause the selected positioning data to change. In cases like these, set the time up to settling of the positioning data to d238.

### ● Positioning Data Setting Selection via communication (d277)

Positioning data can also be assigned via communication. To assign positioning data via communication, set 1 to d277. The upper four digits and lower four digits of the positioning data are assigned to Positioning Data via Communication (MSB) (S20) and Positioning Data via Communication (LSB) (S21), respectively.

To reflect positioning data, turn the position change command "POS-SET" ON.

While commands via communication are enabled, Positioning Data 1 (MSB) (d244) and Positioning Data 1 (LSB) (d245) are switched to S20 and S21. These parameters can also be switched to positioning data 2 to 8 by position command selection 1 "CP1" to position command selection 3 "CP1."



### 6-7-6 Overtravel (OT)

When a movement limit point is passed through, there is the risk of mechanical failure or accident. For this reason, the movement limit point can be detected by the hardware and input digitally as an overtravel (OT) signal. OT detection causes a deceleration stop for the time set in Deceleration Time for Forced Stop (H56) and then servos change to a locked state. When Over Travel Forced Stop Operation Selection (d280) = 1, a deceleration stop is performed and then the Er6 alarm is generated. Plus side overtravel "FOT" and minus side overtravel "ROT" can be allocated independently. The overtravel signal is enabled (NC contact is made) when it is OFF, for safety reasons. When an overtravel is detected, overtravel detection signal "OT-OUT" is output as a digital output.

Parameter No.	Function name	Data	Default data	Unit
E01 to E05 E98 E99	Input Terminal [DI1] Function Selection to Input Terminal [DI7] Function Selection	139 (1139): Forward rotation driving prohibited "FOT" 140 (1140): Reverse rotation driving prohibited "ROT"	-	-
d280	Over Travel Forced Stop Operation Selection	0: Servo lock after deceleration stop 1: Er6 fault occurs after deceleration stop	0	-

### 6-7-7 Software OT

With overtravel (OT), the movement limit point is basically detected by the hardware. However, the limit point position can be set by number of pulses as a software OT. The limit point position can be set in two directions independently by + software OT and - software OT. Operation when a software OT is detected can be selected in Overtravel Function Selection (d222). When an OT limit point does not exist, for example, on a rotating body, leave parameter d222 at its default value (= 0).

Parameter No.	Function name	Data	Default data	Unit
d222	Overtravel Function Selection	0: Invalid/Infinite rotation 1: Valid (Positioning at OT position at over traveling), normal PTP 2: Valid (Immediately stopped at over traveling), normal PTP	0	-
d225	Software Overtravel Detection Position in the Positive Direction (MSB)	-268435455 to 268435455 (MSB: -4,096 to 4,095, LSB: 0 to 65,535)	268435455	-
d226	Software Overtravel Detection Position in the Positive Direction (LSB)			
d227	Software Overtravel Detection Position in the Negative Direction (MSB)	-268435455 to 268435455 (MSB: -4,096 to 4,095, LSB: 0 to 65,535)	-268435455	-
d228	Software Overtravel Detection Position in the Negative Direction (LSB)			

## 6-7-8 Basic Return-to-origin Operation

The return-to-origin operation is started when the RUN command is input with multifunction input terminal “SPD” set to OFF and terminal “ORG” set to ON. Specify the operation direction in Homing Operation Selection (d209). The return-to-origin operation is as follows. Acceleration is performed to the frequency set in Homing Frequency/Orientation Frequency (d213), and, after the moving body has turned origin search limit signal “ORL” ON, movement is performed from the initial Z phase signal (reference signal for homing offset) by the amounts set in the homing offsets (Homing Offset (MSB) (d242) and Homing Offset (LSB) (d243)), and movement is stopped. The positioning completed signal “POK” also is output. When overtravel turns ON before the origin limit switch, reverse rotation operation is performed to search for the origin limit switch.

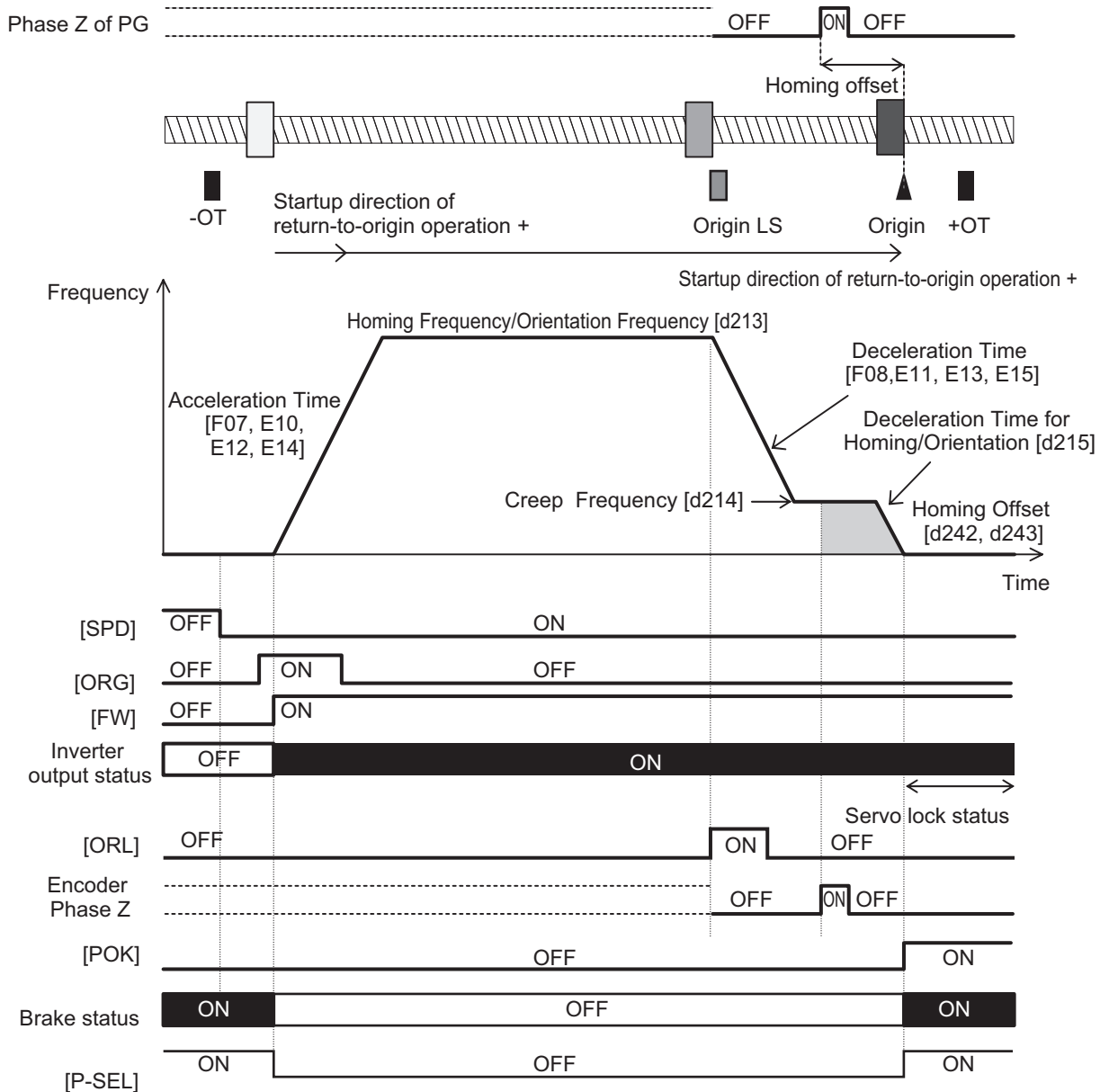

### ● Homing Operation Selection (d209)

This parameter defines the startup direction of return-to-origin operation, moving direction of return-to-origin operation, operation at detection of an overtravel, and limit switch detection timing.

- bit 0 : Startup direction of return-to-origin operation 0: Forward rotation direction, 1: Reverse rotation direction  
Return-to-origin operation starts in the direction defined by this bit regardless of the direction specified in the RUN command from the inverter.
- bit 1 : Direction of return-to-origin operation 0: Forward rotation direction, 1: Reverse rotation direction.  
This bit defines the direction of movement of the return-to-origin operation. When the reverse of the startup direction is set, ORL (origin search limit signal) is detected, then operation is paused and is reversed.
- bit 2 : Return-to-origin operation overtravel operation selection 0: Reversal by overtravel detection, 1: Stop by overtravel detection  
This bit defines whether to stop or reverse operation when an overtravel is detected before ORL (origin search limit signal) is detected.
- bit 3 : Origin limit switch timing selection 0: ON edge detection, 1: OFF edge detection  
This bit defines whether or not to detect the limit switch at its ON edge or OFF edge.

The figure below shows action according to the setting of the d209 parameter. In the figure, it is assumed that bit 2 = 0 and reverse operation is performed at detection of an overtravel.

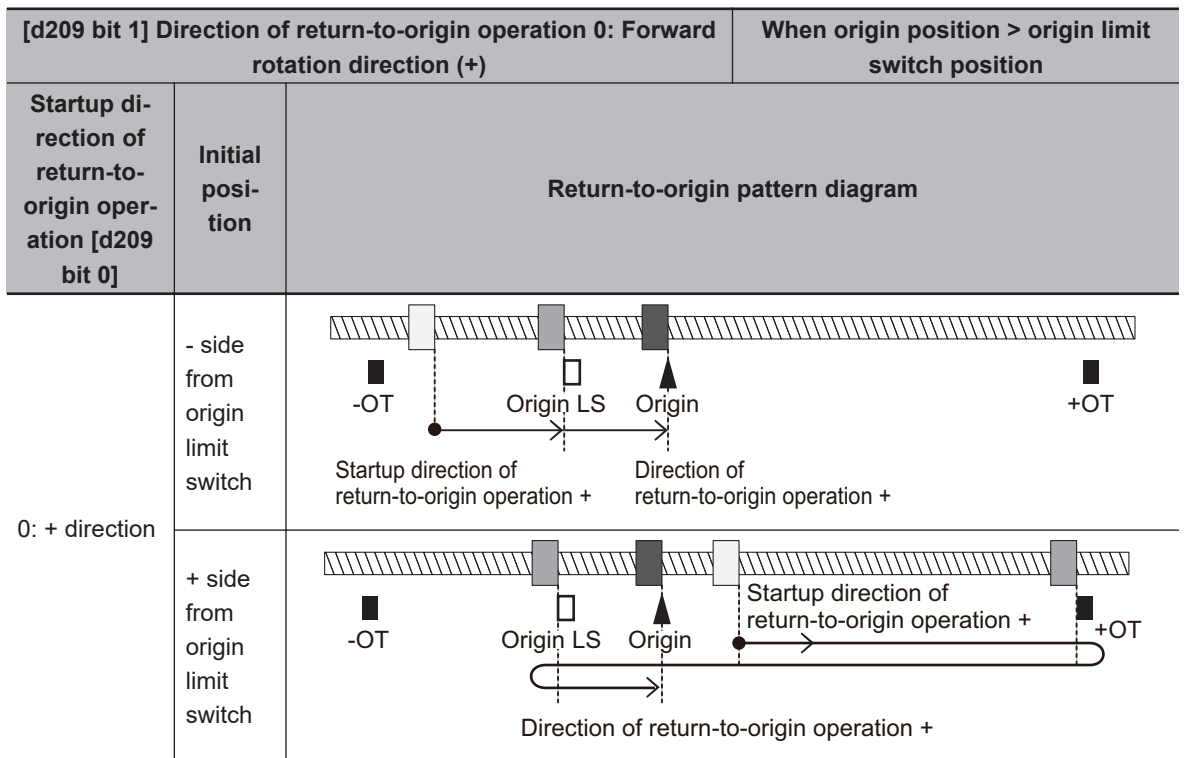

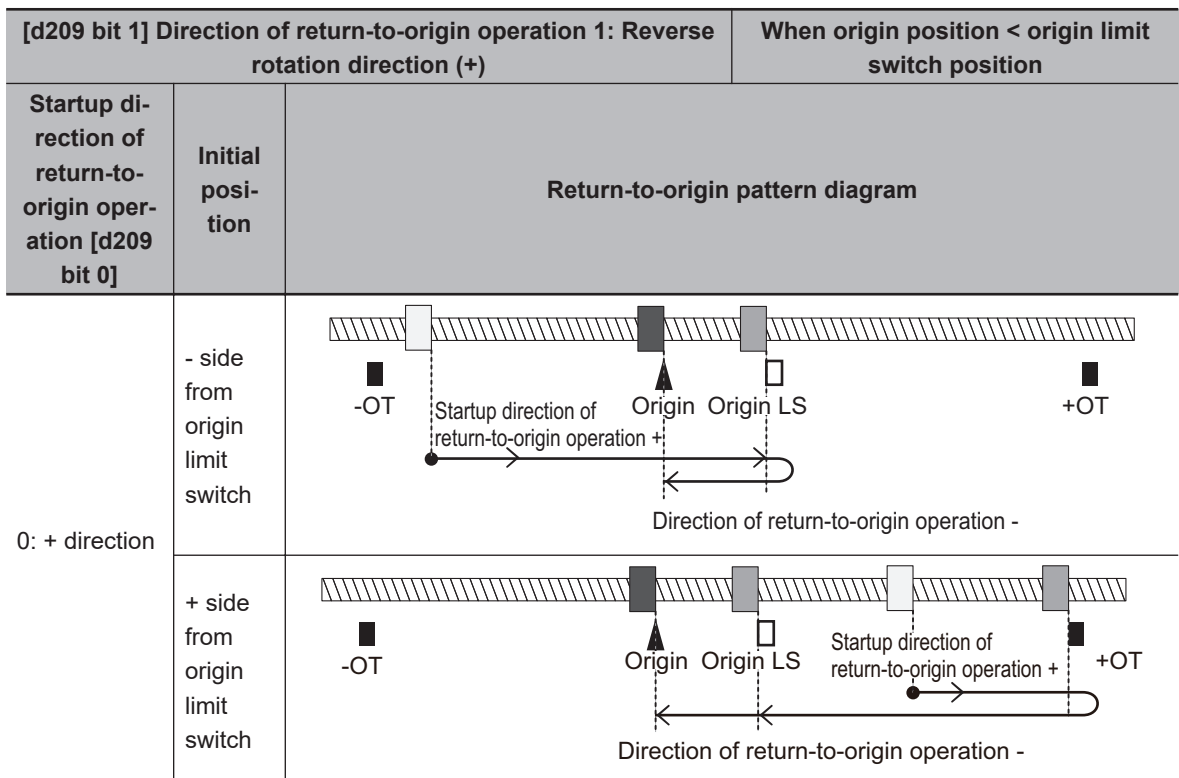
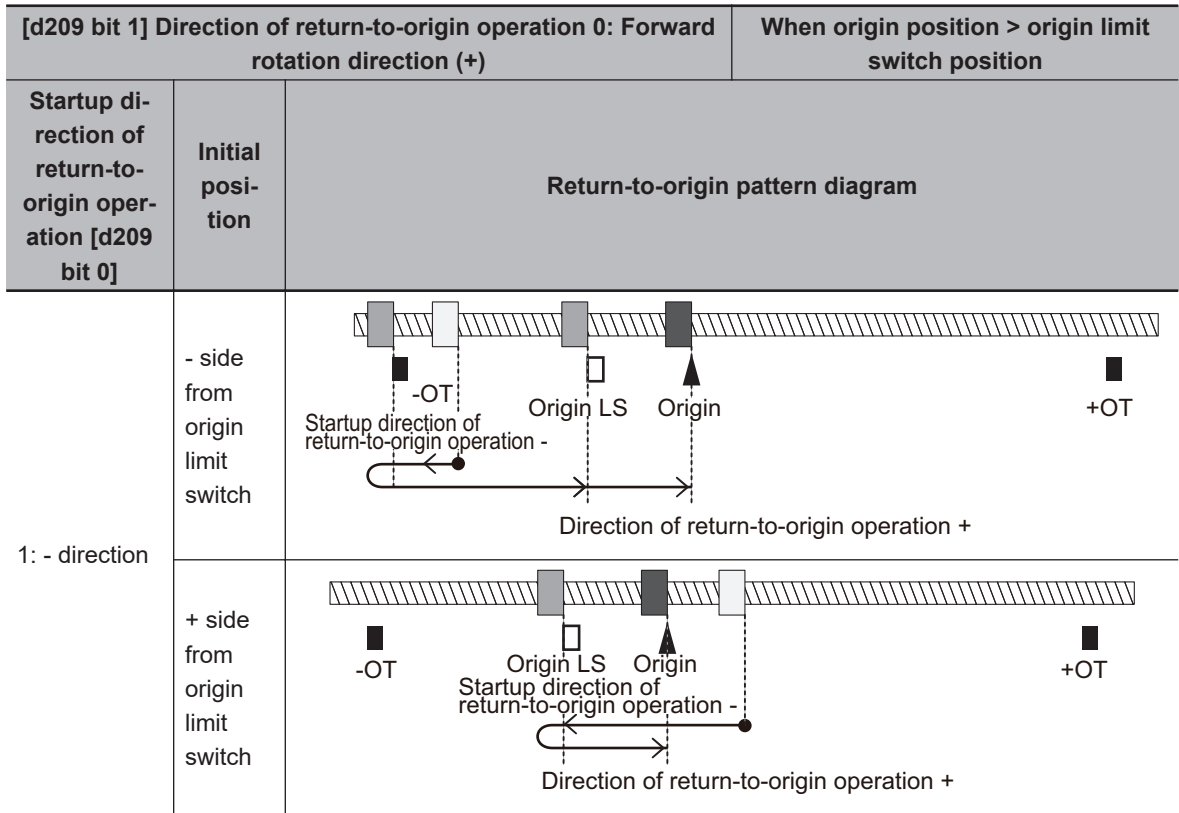

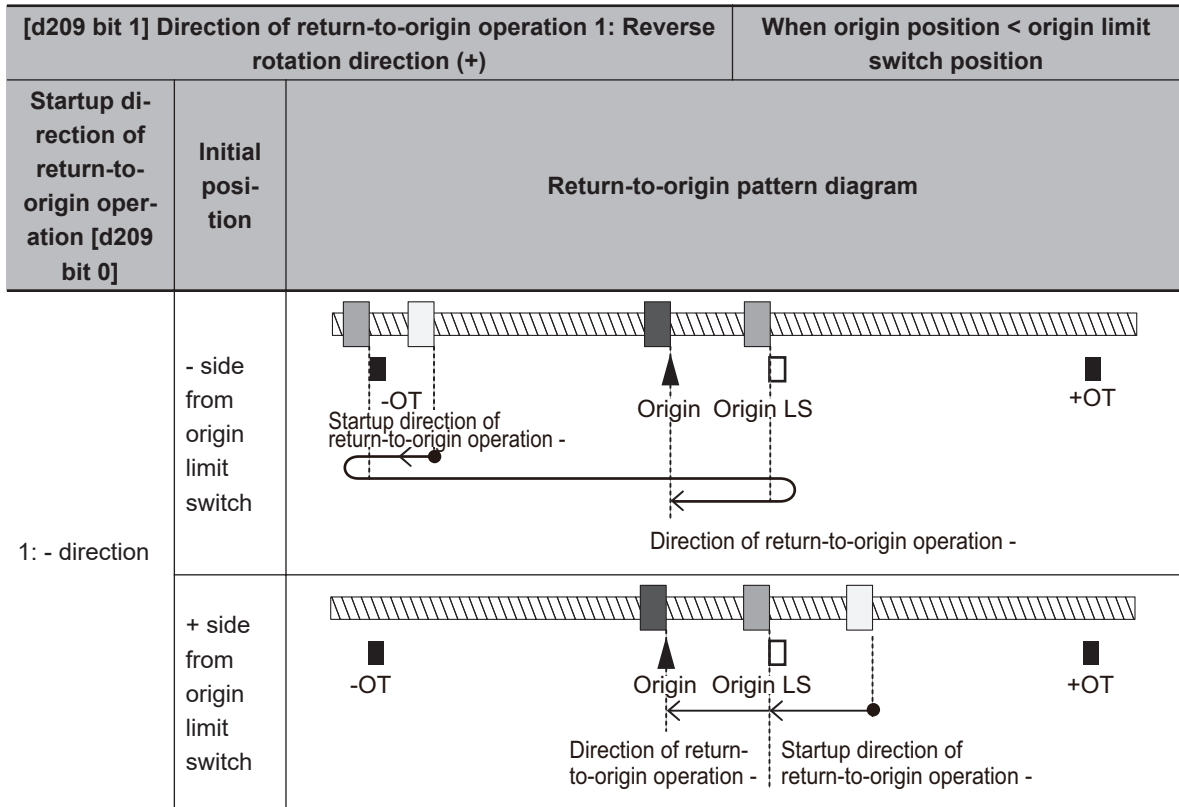

### ● Homing Reference Signal Selection (d211), Reference Signal for Homing Offset (d212)

The reference signal for homing is to switch from the homing frequency to the homing creep frequency. The reference signal for homing starts incrementing of the homing offset. Ordinarily, the signal of the origin limit switch is taken as the reference signal for homing and the Z phase signal is taken as the reference signal for homing offset (factory default). When return-to-origin is configured using other signals, select the reference signal for homing and reference signal for homing offset according to the table below. When Reference Signal for Homing Offset (d212) is set to other than “0: Z pulse of position encoder”, the reference signal for homing is not included in the configuration, and so the Homing Reference Signal Selection (d211) setting is disabled.

Parameter No.	Function name	Data	Default data	Unit
d211	Homing Reference Signal Selection	0: Z phase 1: Origin limit input (ORL) 2: Overtravel input in the positive direction (FOT) 3: Overtravel input in the negative direction (ROT)	1	-
d212	Reference Signal for Homing Offset	0: Z phase 1: Origin limit input (ORL) 2: Overtravel input in the positive direction (FOT) 3: Overtravel input in the negative direction (ROT) 4: Stopper (Hit and stop)	0	-
d214	Creep Frequency	0.1 to 590.0 Hz	0.5	Hz

d211: Reference signal for homing	d212: Reference signal for homing offset	Frequency at start of homing offset	Operation
0: Z phase	0: Z phase (factory default)	Creep frequency	Homing offset is started at the first detection of the Z phase after startup at the creep frequency
1: Origin limit switch (factory default)		Homing frequency to homing creep frequency	
2: Overtravel switch in the positive direction		Homing frequency to homing creep frequency	Deceleration to creep frequency at reverse operation by detection of overtravel
3: Overtravel switch in the negative direction			
Disable	1: Origin limit switch	Homing frequency	
	2: Overtravel switch in the positive direction	Homing frequency to homing creep frequency	Deceleration to creep frequency at reverse operation by detection of overtravel
	3: Overtravel switch in the negative direction		
	4: Stopper	Homing frequency to homing creep frequency	Operation is instantaneously reversed after judgment of collision with the stopper by generation of the torque limit, and homing offset is performed at the creep frequency

### 6-7-9 Clearing of Position

The current position is cleared to zero by digital input "PCLR" turning ON. The current position can be cleared to zero in either position control and speed control. Either of the ON edge and ON level can be selected as the timing to clear the current position.

When "PCLR" is turned ON during position control operation, the current position is cleared to zero and movement to the target position is performed. When "PCLR" is turned ON after position control stop, the current position is cleared to zero, however, movement to the target position is not started. To perform movement, either turn the RUN command OFF then back ON again, or turn "POS-SET" ON.

Parameter No.	Function name	Data	Default data	Unit
E01 to E05 E98 E99	Input Terminal [DI1] Function Selection to Input Terminal [DI7] Function Selection	141 (1141): Current position clear "PCLR"	-	-
d221	Current Position Clear Signal Operation Selection	0: Clear at edge detection 1: Clear at level detection	0	-

## 6-7-10 Position Preset

The current position can be overwritten by the setting of Preset Position (MSB) (d240) and Preset Position (LSB) (d241) at the ON edge of digital input “PSET.” The current position can be preset in either position control and speed control.

When “PSET” is turned ON during position control operation, the current position is overwritten by the preset position and movement to the target position is performed. When “PSET” is turned ON after position control stop, the current position is overwritten, however, movement to the target position is not started. To perform movement, either turn the RUN command OFF then back ON again, or turn “POS-SET” ON.

Parameter No.	Function name	Data	Default data	Unit
E01 to E05 E98 E99	Input Terminal [DI1] Function Selection to Input Terminal [DI7] Function Selection	142 (1142): Current position preset “PSET”	-	-
d240	Preset Position (MSB)	-268435455 to 268435455	0	-
d241	Preset Position (LSB)	(MSB: -4,096 to 4,095, LSB: 0 to 65,535)	0	-

### ● Position control by pulse train input

Position control can be performed with pulse train input used as the pulse position command.

When digital input “SPD” is turned OFF with “12: Pulse train input” set to 1st Frequency Reference Selection (F01)/2nd Frequency Reference Selection (C30), position control is made to operate by taking the pulses according to the pulse train input as the position command pulse.

For details on the pulse train input method, refer to *7-9-17 Pulse Train Frequency Input* on page 7-145.

## 6-7-11 Orientation

The orientation function can be used as an applied function for position control. In speed control, orientation can be performed during operation or while operation is stopped.

### ● Orientation during speed control

With speed control, a motor in rotation can be stopped at a desired mechanical position. When digital input “ORT” is turned ON (②) during operation in speed control, deceleration is performed up to the frequency set in Homing Frequency/Orientation Frequency (d213) for the currently selected deceleration time, control transitions to the position control mode (③), the rotation amount that allows a deceleration stop at the setting in Deceleration Time for Homing/Orientation (d215) up to the position of the currently selected positioning data is calculated from the current position, and the motor rotates for that calculated rotation amount and stops.

The positioning data can be selected from Positioning Data 1 to 8 (d244 to d259) by digital input position command selection signals “CP1,” “CP2” and “CP3”. When assigning positioning data as factory default absolute positions (ABS), the absolute positions are referenced to the Z phase of the encoder. To assign positioning data as absolute positions referenced not to the Z phase of the encoder but to the machine origin position, Positioning Data 1 to 8 (d244 to d259) can be handled as it is as the positioning data of the machine origin reference by setting the position offset of the

“encoder Z phase - machine origin position” to Homing Offset (MSB) (d242) and Homing Offset (LSB) (d243).

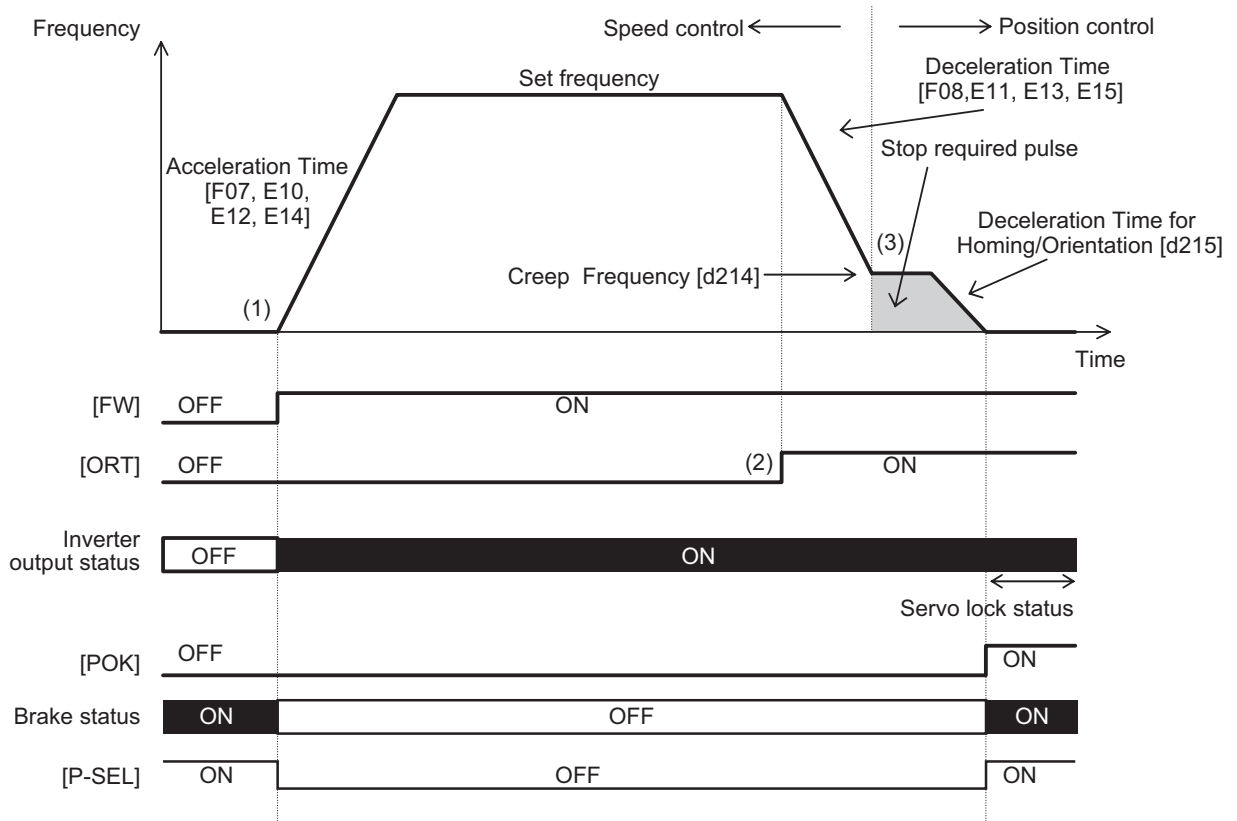

### ● Orientation from a stopped state

When the control mode is vector control with speed sensor, servo lock operation is performed when positioning by orientation is completed, and digital output “POK” is output if positional deviation is within Positioning Completed Range (d239). When the positioning position is changed from this state and orientation is performed again with “POS-SET” set to ON, control changes to position control and positioning is performed within one rotation. At this time, either of “Nearest direction” operation which performs positioning by the shortest distance or “Command direction” operation which follows the direction instructed in the RUN command can be selected at Orientation Selection (d208) regardless of the operation direction. In V/f control with speed sensor, the control mode changes to DC braking and the inverter maintains output. In orientation from a stopped state, rotation is never performed beyond one rotation even if a value exceeding one rotation is programmed in the positioning data.

If the RUN command turns ON after the orientation command “ORT” is turned ON during an inverter output stop, orientation operation is performed immediately without operating up to the set frequency by speed control. Note, however, that when operation is performed after the orientation command “ORT” is turned ON from a stopped state immediately after the power is turned ON, operation by speed control is always performed for one rotation or more to detect the Z phase and the orientation operation is performed.



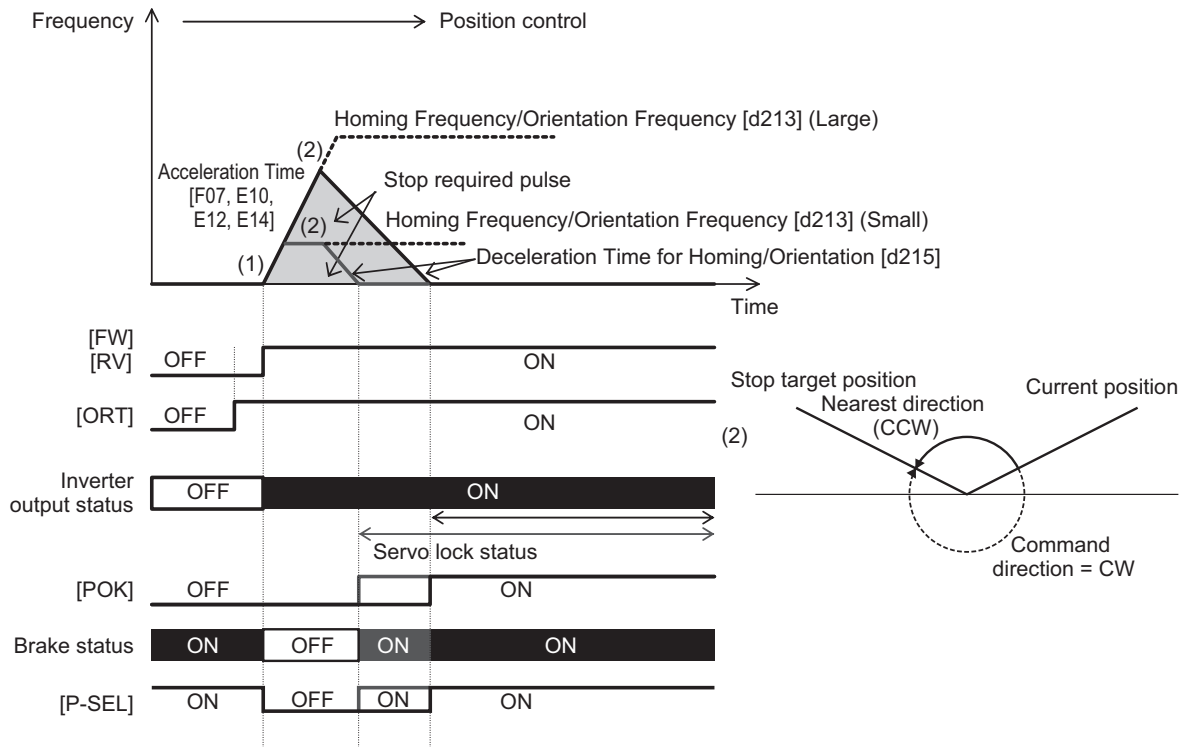

When using the orientation function, vector control with speed sensor, by which speed feedback control is performed by a machine shaft encoder, can be selected as the control mode when the motor to machine shaft transmission gear ratio (speed reduction ratio) is (as a guideline) approx. 5x. In the case of vector control with speed sensor, servo lock operation is performed after a positioning stop, and, if external force is applied after the stop, resistance torque is generated in an attempt to hold the stop position.

On the other hand, when the machine shaft to motor shaft transmission gear ratio (speed reduction ratio) is large, it will be difficult to detect the motor speed at low-speed rotation, and machine performance sometimes can no longer be sufficiently demonstrated unless an encoder with a large number of pulses is used. On machines to which an encoder with a large number of pulses cannot be attached or that have a large transmission gear ratio, use V/f control with speed sensor and not vector control with speed sensor that performs speed feedback control from a machine shaft encoder. Servo lock operation is not possible in V/f control with speed sensor. When an external force is applied after a stop, use a mechanical brake. Also, in V/f control with speed sensor, torque boost sometimes must be adjusted or automatic torque boost sometimes must be set to generate torque at ultra low speeds immediately before a stop.

Parameter No.	Function name	Data	Default data	Unit
E01 to E05, E98, E99	Input Terminal [DI1] Function Selection to Input Terminal [DI7] Function Selection	78(1078): Speed control parameter selection 1 "MPRM1" 79(1079): Speed control parameter selection 2 "MPRM2" 135(1135): Increment/absolute position switching "INC/ABS" 136(1136): Orientation command "ORT" 137(1137): Speed/position switching "SPD" 141(1141): Current position clear "PCLR" 142(1142): Current position preset "PSET" 143(1143): Teaching command "TEACH" 144(1144): Position change command "POS-SET" 145(1145): Position command selection 1 "CP1" 146(1146): Position command selection 2 "CP2" 147(1147): Position command selection 3 "CP3"	-	-
E20 to E21, E27	Output Terminal [DO1] Function Selection to Output Terminal [DO2] Function Selection(E21), Output Terminal [ROA, ROB] Function Selection	82(1082): Positioning completed "POK"	-	-
d03, A45, b45, r45	Speed Control 1 P Proportional Gain, Speed Control 2 P Proportional Gain, Speed Control 3 P Proportional Gain, Speed Control 4 P Proportional Gain	0.1 to 200.0	10.00	time
d04	Speed Control 1 I Integral Time	0.001 to 9.999 s 999: Cancel integral term	0.100	s
A46	Speed Control 2 I Integral Time	0.001 to 9.999 s 999: Cancel integral term		
b46	Speed Control 3 I Integral Time	0.001 to 9.999 s 999: Disable		
r46	Speed Control 4 I Integral Time	0.001 to 9.999 s 999: Disable		
d201	Position Control Feed Forward Gain	0.00: Disable feed-forward 0.01 to 1.50	0.00	-
d202	Position Control Feed Forward Filter	0.000 to 5.000 s	0.500	s
d203	Position Loop Gain 1	0.1 to 300.0	1.0	time

Parameter No.	Function name	Data	Default data	Unit
d204	Position Loop Gain 2	0.1 to 300.0	1.0	time
d205	Position Loop Gain Switch Frequency	0.0 to 590.0 Hz	0.0	Hz
d206	Electronic Gear Denominator	1 to 65535	1	-
d207	Electronic Gear Numerator	1 to 65535	1	-
d208	Orientation Selection	0: Nearest direction (Valid for reverse rotation) 1: Command direction (Direction of operation command source)	1	-
d209	Homing Operation Selection	Bit 7: Z phase correction 0: Disable 1: Enable Bit 4 to 6: Reserved Bit 3: Detection timing of homing limit switch 0: By rising edge 1: By falling edge Bit 2: OT detected operation selection 0: Return at FOT/ROT detection 1: Stop at OT detection (Cancel homing) Bit 1: Homing Start direction 0: Forward direction 1: Reverse direction Bit 0: Homing shaft direction 0: Forward direction 1: Reverse direction	0	-
d213	Homing Frequency/Orientation Frequency	0.1 to 590.0 Hz	5.0	Hz
d215	Deceleration Time for Homing/Orientation	0.00 to 6000 s	6.00	s
d221	Current Position Clear Signal Operation Selection	0: Edge 1: Level	0	-
d237	Positioning Data Type	0: Absolute position (ABS) 1: Relative position (INC)	0	-
d238	Position Data Determination Time	0.000 to 0.100 s	0.000	s
d239	Positioning Completed Range	0 to 9999	1	-
d240	Preset Position (MSB)	-268435455 to 268435455	0	-
d241	Preset Position (LSB)	(MSB: -4,096 to 4,095, LSB: 0 to 65,535)		
d242	Homing Offset (MSB)	-268435455 to 268435455	0	-
d243	Homing Offset (LSB)	(MSB: -4,096 to 4,095, LSB: 0 to 65,535)		

Parameter No.	Function name	Data	Default data	Unit
d244	Positioning Data 1 (MSB)	-268435455 to 268435455 (MSB: -4,096 to 4,095, LSB: 0 to 65,535)	0	-
d245	Positioning Data 1 (LSB)			
d246	Positioning Data 2 (MSB)	-268435455 to 268435455 (MSB: -4,096 to 4,095, LSB: 0 to 65,535)	0	-
d247	Positioning Data 2 (LSB)			
d248	Positioning Data 3 (MSB)	-268435455 to 268435455 (MSB: -4,096 to 4,095, LSB: 0 to 65,535)	0	-
d249	Positioning Data 3 (LSB)			
d250	Positioning Data 4 (MSB)	-268435455 to 268435455 (MSB: -4,096 to 4,095, LSB: 0 to 65,535)	0	-
d251	Positioning Data 4 (LSB)			
d252	Positioning Data 5 (MSB)	-268435455 to 268435455 (MSB: -4,096 to 4,095, LSB: 0 to 65,535)	0	-
d253	Positioning Data 5 (LSB)			
d254	Positioning Data 6 (MSB)	-268435455 to 268435455 (MSB: -4,096 to 4,095, LSB: 0 to 65,535)	0	-
d255	Positioning Data 6 (LSB)			
d256	Positioning Data 7 (MSB)	-268435455 to 268435455 (MSB: -4,096 to 4,095, LSB: 0 to 65,535)	0	-
d257	Positioning Data 7 (LSB)			
d258	Positioning Data 8 (MSB)	-268435455 to 268435455 (MSB: -4,096 to 4,095, LSB: 0 to 65,535)	0	-
d259	Positioning Data 8 (LSB)			
d277	Positioning Data Setting Selection via communication	0: Disable Communications Positioning Data (S20, S21) 1: Enable Communications Positioning Data (S20, S21)	0	-

- **Position Loop Gain 1 (low speed side) (d203), Position Loop Gain 2 (high speed side) (d204)**

- **Position Loop Gain Switch Frequency (d205)**

- **Speed control P (gain) (d03,A45,b45,r45)**

- **Speed control I (integral time) (d04,A46,b46,r46)**

In orientation operation, the response of position control can be switched during deceleration and during a stop.

The larger the set value, the more improved response becomes, the shorter the settling time becomes and the more holding performance can be improved during a servo lock stop. However, setting too large a value causes hunting. Adjust this parameter so that hunting does not occur. Also, when increasing the gain of the position controller, also adjust the speed adjuster (ASR). To switch speed control P (gain) and speed control I (integral time), use parameter selection 1 and 2 "MPRM1" and "MPRM2."

- **Electronic Gear Denominator (d206), Electronic Gear Numerator (d207)**

Positioning data in orientation can be handled as an angle, number of pulses or other user value.

Ex- When the PG of number of pulses 1024 [pulse/rev] is used and the moving amount per user value is 1 am [pulse/user value] for the equivalent number of pulses 4x the PG pulses  
ple  
)

$$\frac{\text{Electronic gear numerator}}{\text{Electronic gear denominator}} = \frac{\text{Moving amount per user value}}{\text{Moving amount per 1 PG pulse}} = \frac{\frac{1}{4 \times 1024} [\text{rev/user value}]}{\frac{1}{1024} [\text{rev/pulse}]} = \frac{1}{4} [\text{pulse/user value}]$$

Ex- When the moving amount per user value is 0.01 [°/user value], the moving amount per single motor am rotation is 360.00 [°/rev], and the number of PG pulses per single motor rotation is 4096 (1024 × 4x)  
ple [pulse/rev]  
)

$$\frac{\text{Electronic gear numerator}}{\text{Electronic gear denominator}} = \frac{\text{Moving amount per user value}}{\text{Moving amount per 1 PG pulse}} = \frac{0.01 [^\circ/\text{user value}]}{\frac{360.00 [^\circ/\text{rev}]}{4096 [\text{pulse/rev}]}} = \frac{4096}{36000} [\text{pulse/user value}]$$

### ● Orientation Selection (d208)

When Orientation Selection (d208) is set to “0: Nearest direction (Valid for reverse rotation),” the moving amount to the positioning data instructed from the current position rotates in the smaller direction (nearest direction) regardless of the direction instructed in the RUN command. Note, however, that when operation has not been performed even once after the power is turned ON, operation starts in the direction instructed in the RUN command and orientation is performed as the near direction is unknown. Then, positioning is performed by the nearest direction. When Orientation Selection (d208) is set to “1: Command direction (Direction of operation command),” operation starts in the direction instructed in the RUN command at all times and orientation is performed.

### ● Homing Operation Selection (d209)

In a pulse encoder, variance sometimes occurs between the output timing of the A, B phase pulses and Z phase pulse. If a position error of one pulse occurs on the machine side when positioning is performed to the same position during forward rotation and reverse rotation, set 1 to “bit 7: Z phase correction” in Homing Operation Selection (d209). Occurrence of position error caused by the rotational direction can be suppressed by enabling this correction.

### ● Homing Frequency/Orientation Frequency (d213)

This is the frequency when speed control is switched to position control by the orientation command “ORT” during speed control. If the preset frequency is high, the time up to completion of positioning increases, and when torque limit deceleration is performed, the position deviation over (oF) alarm sometimes occurs. To perform torque limit deceleration, set the frequency when switching from speed control to position control to as low a frequency as possible.

In V/f control with speed sensor, when the preset frequency is low, it becomes difficult to position to the instructed positioning position unless torque boost is adjusted or automatic torque boost is used. Adjust all of Deceleration Time for Homing/Orientation(d215), Position Loop Gain 1 (low speed side) (d203) and Position Loop Gain 2 (high speed side) (d204) so that the desired settling time is reached in keeping with the control method.

### ● Deceleration Time for Homing/Orientation (d215)

Set the deceleration time from Homing Frequency/Orientation Frequency (d213). This deceleration time can be adjusted to adjust the set time when overtravel or overshooting occurs on the instructed position.

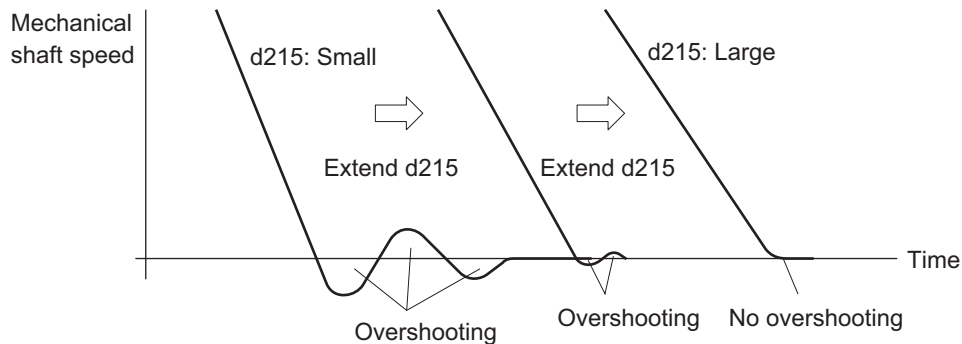

### ● Preset Position (MSB) (d240), Preset Position (LSB) (d241)

The current reference position and current feedback position can be set to any position referenced to the machine origin. In orientation, ordinarily, the position offset between the machine origin and the Z phase of the encoder is handled as the homing offset. For this reason, set Preset Position (MSB) (d240) and Preset Position (LSB) (d241) as "0."

### ● Homing Offset (MSB) (d242) and Homing Offset (LSB) (d243)

The homing offset in orientation is equivalent to the position offset between the machine origin and the Z phase of the encoder. Adjust the homing offset by the following procedure.

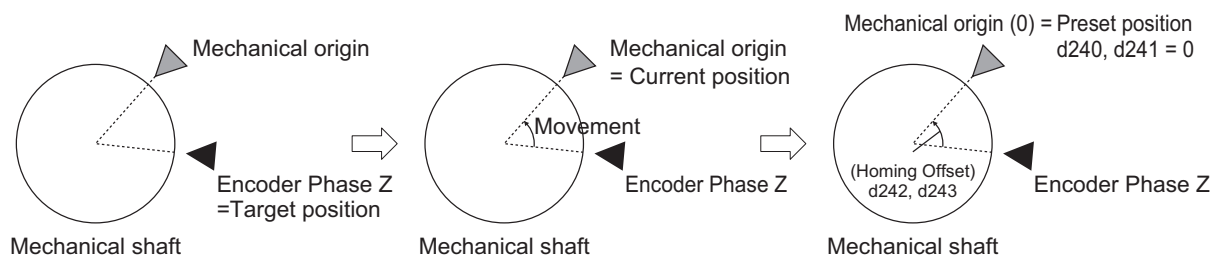

- 1) When the orientation command is turned ON with the target position set as 0, perform positioning with the Z phase position of the encoder as the origin.
- 2) Then, operate the motor, and move the machine shaft to the machine origin position and stop movement there. Set the Current Feedback Position Monitor (MSB) (d298) and Current Feedback Position Monitor (LSB) (d299) at this time to Homing Offset (MSB) (d242) and Homing Offset (LSB) (d243). Then, when the current position preset "PSET" is turned ON with Preset Position (MSB) (d240) and Preset Position (LSB) (d241) set to "0," "0" is set to Current Feedback Position Monitor (MSB) (d298) and Current Feedback Position Monitor (LSB) (d299).
- 3) For confirmation, perform orientation again. Perform orientation with the current position as "0" (origin), and check that orientation to the machine origin position is possible.

### ● Positioning Data 1 to 8 (d244 to d259) and Position Data Determination Time (d238)

This parameter is for setting the positioning position referenced to the machine origin in orientation. Up to eight points can be set, and multipoint positioning can be performed continuously by using position command selection 1 to 3 "CP1 to CP3." To prevent malfunction caused by chattering when the position command selection signal is used to switch positioning data, set a time for

chattering to settle or longer in Position Data Determination Time (d238). To enable changes to the positioning data with the RUN command ON, be sure to turn the position change command “POS-SET” ON. As changes to the positioning data while the RUN command is OFF are reset when operation is started, operation by position change command “POS-SET” is not required.

Orientation operation differs from position control in that, even when a value greater than one rotation is set to positioning data, the value is automatically corrected to a position within one rotation when the operation is actually performed.

To assign positioning data as an incremental amount of movement relative to the current position, set movement in Positioning Data Type (d237). To switch handling when necessary, use increment/absolute position switching “INC/ABS” (data = 135) in the multifunction input terminal function. When this function is allocated, the d237 setting is disabled.

### ● Positioning Data Setting Selection via communication (d277)

In orientation, to use Positioning Data via Communication (MSB) (S20) and Positioning Data via Communication (LSB) (S21) via communication to perform positioning, set “1” to Positioning Data Setting Selection via communication (d277) to enable positioning commands via communication, just as in position control.

## 6-7-12 Functions That Are Disabled in Position Control

When speed/position switching is set to “SPD” OFF and the RUN command is ON, the following functions are disabled.

Jogging operation, PID control, starting frequency hold, stop frequency hold, DC braking, Zero Speed Control, restart after momentary power failure, retry, offline tuning, anti-regenerative control, overload prevention, Stop Selection (H11), pickup, torque control, 1st/2nd control.

## 6-7-13 Position Monitor

Use this function to monitor the feedback current position and instructed current position on the Digital Operator. The feedback current position is the value obtained by totaling the number of feedback pulses and converting them to user values. The instructed current position is not the target position but the momentary instructed position based on the position instruction pattern, and is the same as the feedback current position during a stop.

Parameter No.	Function name	Data	Default data	Unit
d296	Current Reference Position Monitor (MSB)	-268435455 to 268435455 (MSB: -4096 to 4095, LSB: 0 to 65535)	-	-
d297	Current Reference Position Monitor (LSB)		-	
d298	Current Feedback Position Monitor (MSB)	-268435455 to 268435455 (MSB: -4096 to 4095, LSB: 0 to 65535)	-	-
d299	Current Feedback Position Monitor (LSB)		-	

### 6-7-14 Restarting Positioning

If the motor moves out of the Restarting Positioning Range Setting (d278) while operation is still ON after positioning is performed by position control, the inverter automatically starts repositioning the motor again. When the motor is in the Positioning Completed Range (d239) even if outside of the position restarting range, the motor does not operate.

When the motor current position moves out of the range  $\pm d278$  from the target value, it moves to the target position.

The restarting positioning function is useful in V/f control. In vector control, servo lock operation is performed after completion of position control operation, so processing to stop at the target position functions at all times.

When the current position is overwritten during a stop, the restarting positioning function is disabled.

Parameter No.	Function name	Data	Default data	Unit
d239	Positioning Completed Range	0 to 9999	1	-
d278	Restarting Positioning Range Setting	0: Invalid 1 to 9999	9999	-

### 6-7-15 Brake Control during Position Control

The output state of the brake signal during a position control stop can be set at bit 6 of Brake Control Operation Selection (J96).

#### At Brake Release

In V/f control, with the RUN command ON, when the output current is at the current set in Brake Control Brake-release Current (J68) or higher, the frequency reference is at the frequency set in Brake Control Brake-release Frequency (J69) or higher, and the time set in J70 elapses, "BRK" is turned ON regardless of the setting of J96 bit 6.

In vector control, when J96 bit 6 = 0, the RUN command is ON, the output current is at the current set in Brake Control Brake-release Current (J68) or higher, the torque command is at the torque set in Brake control Brake-release Torque (J95) or higher, and the time set in J70 elapses, "BRK" is turned ON.

In vector control, if the output current is at the current set in Brake Control Brake-release Current (J68) or higher, the torque command is at the torque set in Brake control Brake-release Torque (J95) or higher, and the time set in Brake Control Brake-release Timer (J70) elapses when J96 bit 6 = 1 and the servo lock state is entered by the servo lock terminal turning ON, the brake release signal "BRK" is turned ON even if the RUN command is OFF.

#### At Application of Brake

When a stop is made at the target position with J96 bit 6 = 0, the brake release signal "BRK" is turned ON when the time set at Brake Control Brake-applied Timer (J72) elapses even if the RUN command is ON.



When a stop is made at the target position with J96 bit 6 = 1, the brake release signal “BRK” is not turned ON even if the time set at Brake Control Brake-applied Timer (J72) elapses if the RUN command is ON.

When the brake is applied during position control, the motor cannot rotate even if there exists position error. For this reason, the integral term accumulates which sometimes causes an overload trip to occur. When ASR integral term cancel “P-SEL” allocated to a multifunction input terminal is turned ON, the integral term of the speed controller is canceled and P operation is performed.

Parameter No.	Function name	Data
J96	Brake Control Operation Selection	bit 6 = 0: Position control stopped, brake signal OFF (brake applied) bit 6 = 1: Position control stopped, brake signal ON (brake released)
E01 to E05, E98, E99	Input Terminal [DI1] Function Selection to Input Terminal [DI7] Function Selection	119: P-SEL (ASR integral term cancellation)

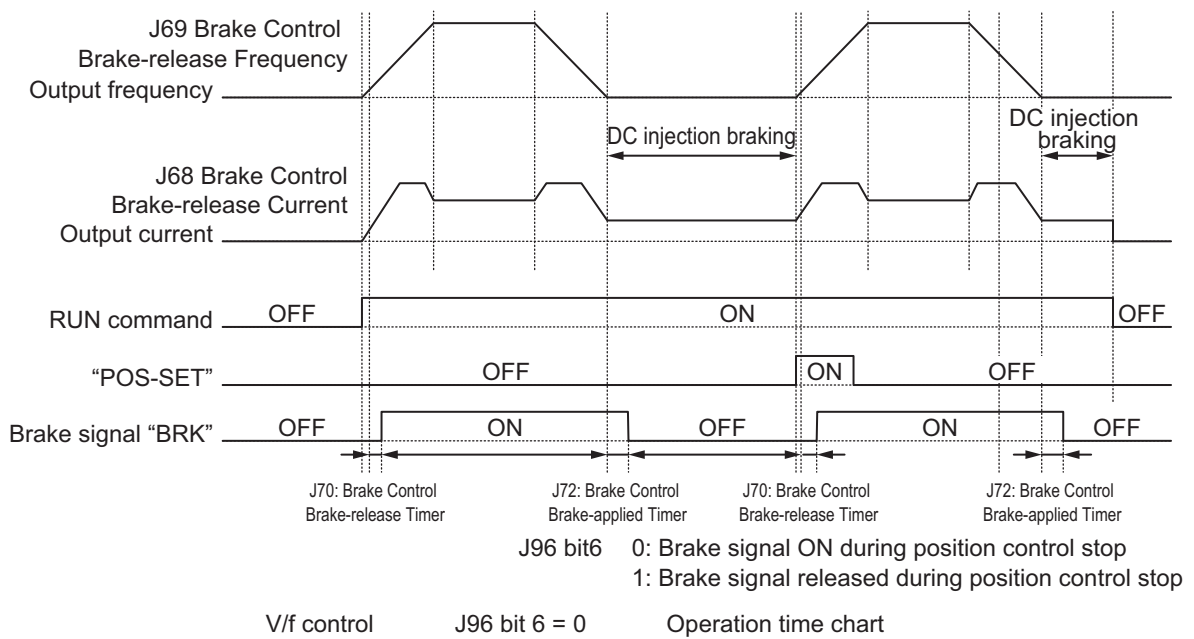

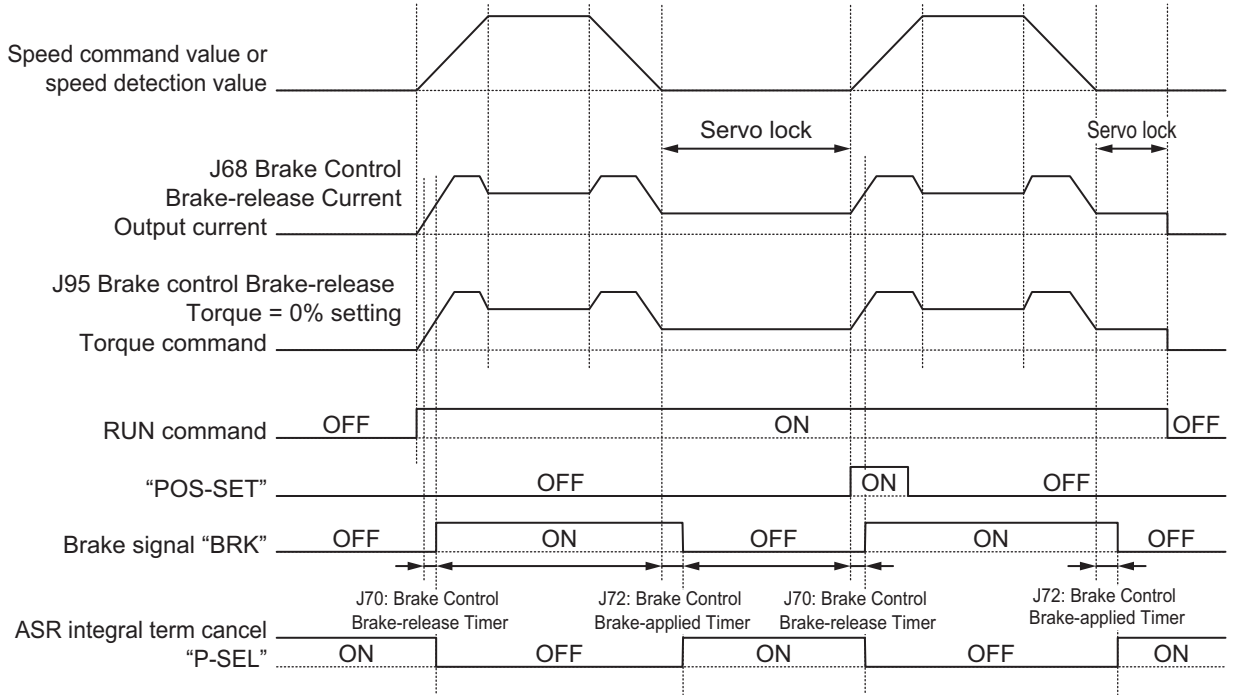

J96 bit6 0: Brake signal ON during position control stop  
1: Brake signal released during position control stop

Vector control J96 bit 6 = 0 Operation time chart

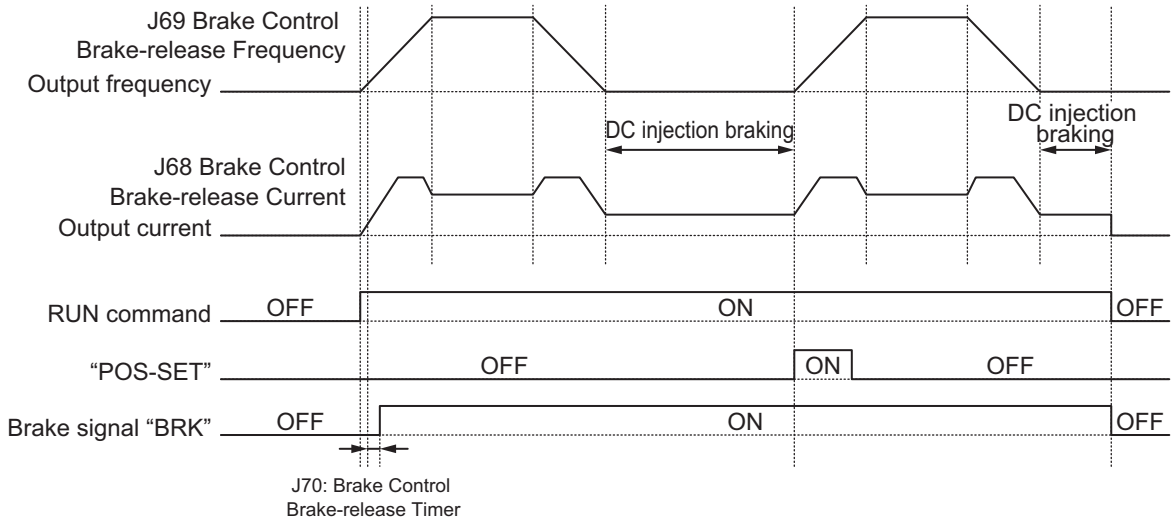

J96 bit6 0: Brake signal ON during position control stop  
1: Brake signal released during position control stop

V/f control J96 bit 6 = 0 Operation time chart

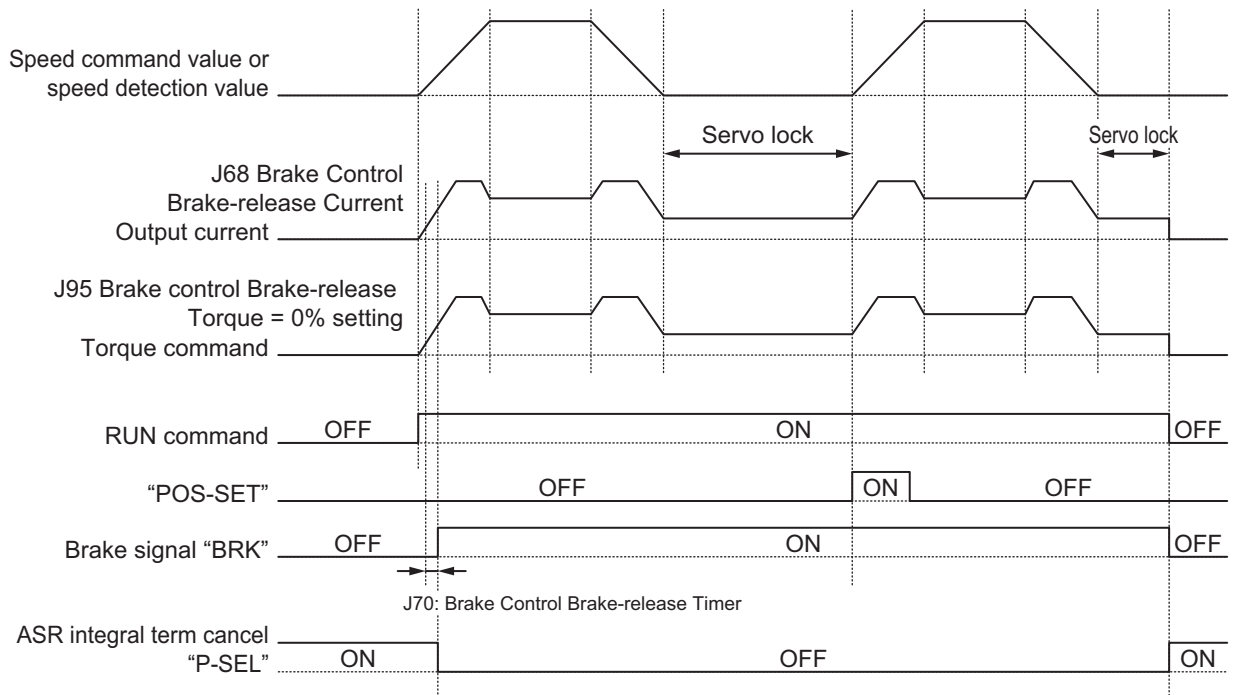

J96 bit6 0: Brake signal ON during position control stop  
1: Brake signal released during position control stop

Vector control J96 bit 6 = 0 Operation time chart

### 6-7-16 Position Store Selection at Power OFF

When d220 is set to "1: Store at low voltage status," the data of the current feedback position (d298, d299) is stored to EEPROM when an insufficient voltage state occurs, and is restored at the next power ON. When "0: Invalid" is set, the data is cleared to zero at the next power ON.

Even if store to EEPROM is enabled when an insufficient voltage state occurs, when the motor rotates with the power supply shut off, the rotation amount cannot be detected and this causes position error. When this function is used, use of the mechanical brake is recommended.

Parameter No.	Function name	Data	Default data	Unit
d220	Position Feedback Store Selection at Power Off	0: Disable 1: Store at low voltage detected	0	-

### 6-7-17 Excessive Positional Deviation

Excessive positional deviation is judged when the deviation between the current reference position and current feedback position exceeds the detection level of excessive positioning deviation (d223, d224).

When excessive positional deviation occurs, the excessive positional deviation alarm (d0) is immediately output and the motor runs freely.

In position control, the current reference position is overwritten with the current feedback position when inverter output turns OFF, and the positional deviation of APR is cleared. For this reason, the excessive positional deviation alarm (d0) can be reset when the alarm stops and inverter output turns OFF.

Positional deviation is closely related to positioning frequency and position command gain. When a certain frequency reference is output at a certain position reference gain, a constant positional deviation is always required. Due to this fact, positional deviation can be improved by either increasing the detection level of excessive positioning deviation (d223, d224) or by increasing the position control gain (d203 and d204) when the excessive positional deviation alarm (d0) occurs.

Parameter No.	Function name	Data	Default data	Unit
d223	Detection Level of Excessive Positioning Deviation (MSB)	0: Disable (MSB: 0, LSB: 0)	0	-
d224	Detection Level of Excessive Positioning Deviation (LSB)	1 to 268435455 (MSB: 0 to 4,095, LSB: 0 to 65,535)	0	-

## 6-7-18 Touch Probe (Latch) Function

This is a function that latches the feedback position and the time stamp, when the external latch input signal or the encoder Z-phase is started.

This function is disabled if neither of “187: EXT1 (External latch input 1)” and “188: EXT2 (External latch input 2)” is allocated to Input Terminal [DI1] Function Selection (E01) and Input Terminal [DI2] Function Selection (E02), and if the selection trigger is not encoder Z-phase.

This function is also disabled when bit 0 (Latch function 1) and bit 8 (Latch function 2) of Touch Probe Function (H437) are 0.

Parameter No.	Function name	Data	Default data	Unit
H435	Touch Probe 1 Source	1: External Latch Input 1 (EXT1) 2: External Latch Input 2 (EXT2) 6: Encoder Phase Z	1	-
H436	Touch Probe 2 Source	1: External Latch Input 1 (EXT1) 2: External Latch Input 2 (EXT2) 6: Encoder Phase Z	1	-
H437	Touch Probe Function	0000 to FFFF hex	0	-
W148	Touch Probe 1 Positive Edge (MSB)	-4096 to 4095	0	-
W149	Touch Probe 1 Positive Edge (LSB)	0 to 65535	0	-
W150	Touch Probe 2 Positive Edge (MSB)	-4096 to 4095	0	-
W151	Touch Probe 2 Positive Edge (LSB)	0 to 65535	0	-
W152	Touch Probe Status	0000 to FFFF hex	0	-
E01,E02	Input Terminal [DI1] Function Selection, Input Terminal [DI2] Function Selection	187: EXT1 (External latch input 1)*1 188: EXT2 (External latch input 2)*1	-	-

\*1. External latch cannot be allocated to other than multifunction input DI1 and DI2.

## Setting the Trigger Signal

The trigger of the touch probe function can be selected as shown in the figure below.

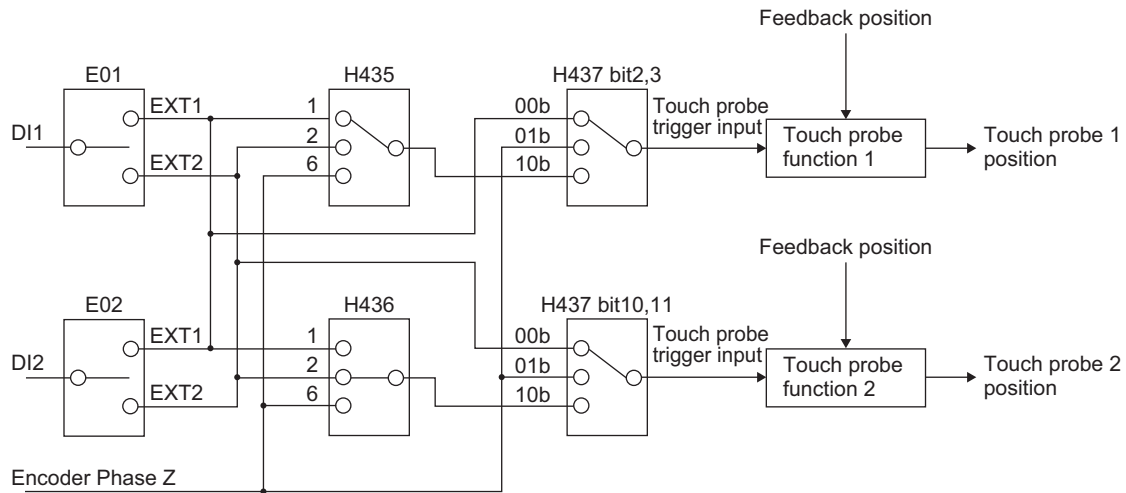

### Explanation of Bits of Touch Probe Function (H437)

Each bit of the touch probe function is as shown below.

b15	b14	b13	b12	b11	b10	b9	b8	b7	b6	b5	b4	b3	b2	b1	b0
0	0	0	EPs	TriSel	Cont	Ena	0	0	0	EPs	TriSel	Cont	Ena		
Touch probe function 2							Touch probe function 1								

Ena: Touch probe function disabled (0) or enabled (1)

Cont: Touch probe operation Trigger First Event Mode(0) / Continuous Mode(1)

TriSel: Touch probe trigger input switching

bit 3(11)	bit 2(10)	Select trigger input
0	0	EXT1
0	1	Z-phase
1	0	According to the touch probe trigger selection H435 and H436
1	1	The trigger signal input is considered to be "0."

Eps: Latch operation enabled (1) or disabled (0) during Active edge

### Explanation of Bits of Touch Probe Status (W152)

Each bit of the touch probe status is as shown below.

b15	b14	b13	b12	b11	b10	b9	b8	b7	b6	b5	b4	b3	b2	b1	b0
0	0	0	0	0	0	PLc	Enb	0	0	0	0	0	0	PLc	Enb
Touch probe function 2							Touch probe function 1								

Enb: Touch probe function disabled (0) or enabled (1)

PLc: With (0) or without (1) Latch positive data

## Operation Sequence

### ● For Cont = 0: Trigger First Event Mode (First Trigger)

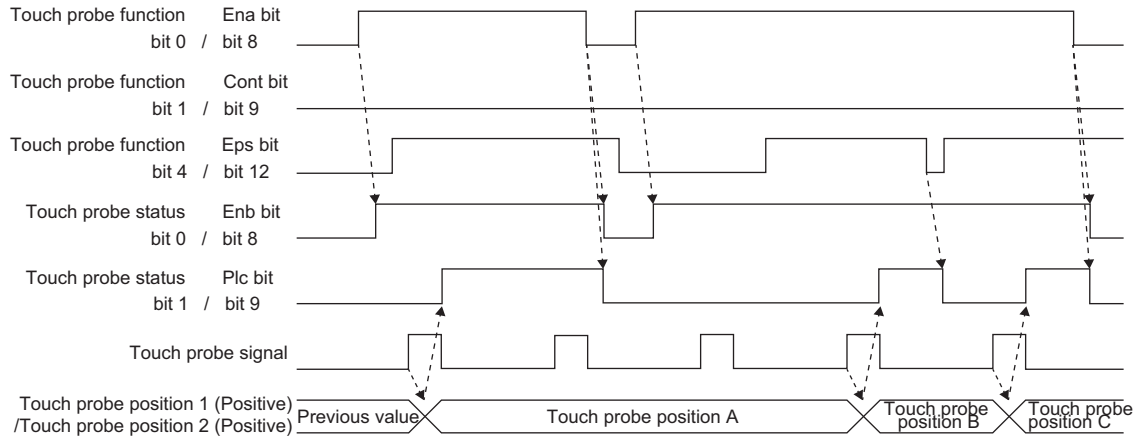

### ● For Cont = 1: Continuous Mode (Continuous)

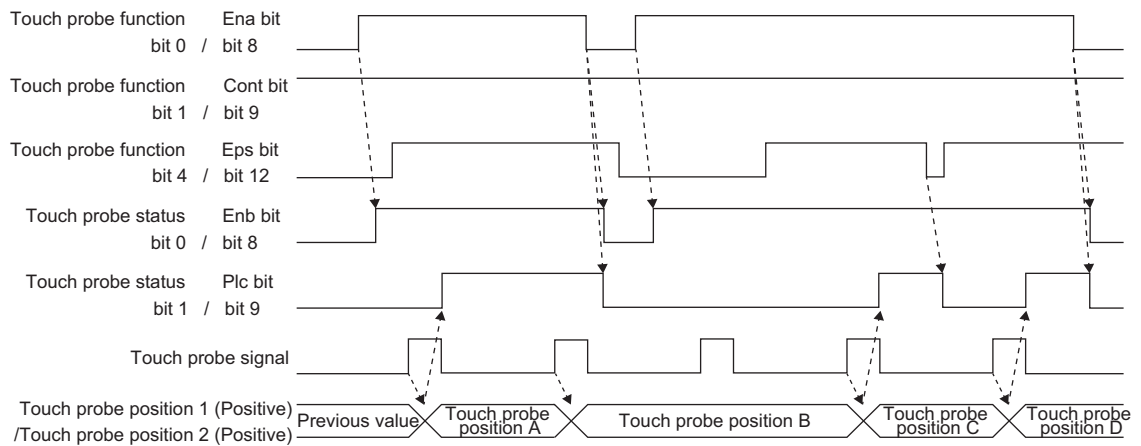

## 6-8 Motor tuning

### 6-8-1 Motor Off-line Auto-tuning

To perform auto-tuning of the motor, perform the settings according to the control method in 6-1-3 *Motor Parameter Settings* on page 6-6, and then perform according to the following procedure.

#### Offline Auto-tuning of Induction Motor (IM Motor)

Offline auto-tuning consists of the following five steps:

- Presetting of parameters
- Selection of motor rotation during auto-tuning
- Execution of auto-tuning
- Processing after auto-tuning
- Corrective action in case of an error

#### 1 Presetting of parameters

- 1) Set one of "0: IM V/f control," "1: IM Dynamic torque vector control," "3: IM V/f control with speed sensor," "4: IM Dynamic torque vector control with speed sensor," "5: IM Vector control without speed sensor" or "6: IM Vector control with speed sensor" to 1st Drive Control Selection (F42)/2nd Drive Control Selection (A14).
- 2) Referring to 6-1-3 *Motor Parameter Settings* on page 6-6, set parameters matched to the control method.

#### 2 Selection of tuning method

Check the machine status, and select either "2: Tune the motor parameters while rotating" or "1: Tune the motor parameters while stopped" in 1st Auto Tuning Function Selection (P04)/2nd Auto-tuning Selection Function Selection (A18). When the wiring length has changed after rotation tuning is performed, tuning can be performed by "5: Tune the motor %R1 and %X while stopped."

P04/A18 data		Data to be tuned	Tuning	Supplementary explanation
1	Tune the motor parameters while stopped	Primary resistance %R1 (P07/A21) Leakage reactance %X (P08/A22) Rated slip (P12/A26) %X correction factor (P53/A53)	Tuning is performed in a stop state.	When the motor cannot be rotated.

P04/A18 data		Data to be tuned	Tuning	Supplementary explanation
2	Tune the motor parameters while rotating	No-load current (P06/A20) Primary resistance %R1 (P07/A21) Leakage reactance %X (P08/A22) Rated slip (P12/A26) Magnetic saturation factor 1 to 5 (P16/A20) %X correction factor (P53/A53)	Tuning is performed in the following order. <ul style="list-style-type: none"> <li>• %R1, %X in motor stopped state</li> <li>• No-load current and magnetic saturation factor in motor rotating state (50% of base frequency)</li> <li>• Rated slip in motor stopped state again</li> </ul>	When the motor can be rotated safely.
5	Tune the motor %R1 and %X while stopped	Primary resistance %R1 (P07/A21) Leakage reactance %X (P08/A22) %X correction factor (P53/A53)	Tuning is performed in a stop state.	When the motor cannot be rotated. (Applied only when rotation tuning has been performed and the wiring length has been changed)

The tuning result is automatically written to the relevant parameter.



### 3 Preparing the mechanical system

As preparation for performing rotation tuning, remove machine couplings, and disable safety interlocks.

### 4 Execution of auto-tuning

- 1) Set one of 1, 2 or 5 to parameter P04, and press the  key. 1, 2 and 5 blink slowly.

Parameter No.	Function name	Data	Default data	Unit
P04	1st Auto Tuning Function Selection	1: Tune the motor parameters while stopped 2: Tune the motor parameters while rotating 5: Tune the motor %R1 and %X while stopped	0	-

- 2) Input the RUN command. In the factory default state, forward rotation is performed when the  key is pressed in an enabled state. To perform reverse rotation or when the RUN command is input via the FW or RV terminals, change the setting of F02.
- 3) When the RUN command is input, 1, 2 and 5 light and tuning is started with operation stopped. The time required for auto-tuning is approx. 5 to 40 seconds.
- 4) After (3) above is completed when P04 = 2, acceleration is performed up to 50% of the rated speed and rotation tuning is started. When rotation tuning is completed, a deceleration stop is performed. The time required for this operation is 10 seconds excluding the acceleration/deceleration time.
- 5) When the RUN command via the FW and RV terminals is selected according to the F02 = 1 setting, tuning is completed when  is displayed. Turn the RUN command OFF. When



the RUN command was input via the touch panel or via communication, the RUN command is shut off automatically as soon as tuning is completed.

6) When tuning is completed, the following parameter No. is displayed.

## 5 Corrective action in case of an error

As unwanted tuning might cause hunting or other malfunctions or worsen operational accuracy, the inverter generates Er7 and discards tuning values when an abnormality is found in the tuning result.

When tuning ends in an error (Er7), check the following.

- Is inverter output wiring open?
- Has the mechanical brake operated?
- Has the free-run command "FRS" turned ON?
- Are parameter settings correct?

For details on the tuning error (Er7), refer to *Tuning Error* on page 6-69.

## Offline Auto-tuning of Synchronous Motor (PM Motor)

Offline auto-tuning consists of the following five steps:

- Presetting of parameters
- Selection of tuning method
- Preparing the mechanical system
- Execution of auto-tuning
- Corrective action in case of an error

### 1 Presetting of parameters

- 1) Set "15: PM Vector control without speed and pole position sensor" or "16: PM Vector control with speed and pole position sensor" to 1st Drive Control Selection (F42).
- 2) By referring 6-1-3 *Motor Parameter Settings* on page 6-6, set parameters matched to the control method.

### 2 Selection of tuning method

Check the machine status, and select either "2: Tune the motor parameters while rotating" or "1: Tune the motor parameters while stopped" in 1st Auto Tuning Function Selection (P04). When performing only offset adjustment of the magnetic pole position sensor, select "4: Tune the PM motor magnetic pole position offset while rotating." After tuning is finished, adjust the acceleration time and deceleration time, and conformity between the rotational direction of the motor and rotational direction of the machine.

P04 data		Data to be tuned	Tuning	Supplementary explanation
1	Tune the motor parameters while stopped	1st PM Motor Armature Resistance (P60) 1st PM Motor d-axis Inductance (P61) 1st PM Motor q-axis Inductance (P62)	Tuning is performed in a stop state.	When the motor cannot be rotated. For example, when the load cannot be removed. P30 = 1 or 2

P04 data		Data to be tuned	Tuning	Supplementary explanation
2	Tune the motor parameters while rotating	1st PM Motor Armature Resistance (P60) 1st PM Motor d-axis Inductance (P61) 1st PM Motor q-axis Inductance (P62) 1st PM Motor Induced Voltage Ke (P63)	The armature resistance, d-axis inductance and q-axis inductance are tuned in a motor stop state. After this, rotation is performed up to 50% of the rated frequency to tune the induced voltage.	When the motor can be rotated safely.
		1st PM Motor Magnetic Pole position Offset (P95)	The magnetic pole position sensor offset is tuned in a motor rotating state (speed according to d80)	This is implemented only on the case of PM Vector control with speed and pole position sensor (F42 = 16) using an A, B phase + U, V, W phase magnetic pole position detection type (d14 = 4) encoder.
4	Tune the PM motor magnetic pole position offset while rotating	1st PM Motor Magnetic Pole position Offset (P95)	The magnetic pole position sensor offset is tuned in a motor rotating state (speed according to d80)	This is performed when performing tuning of only the magnetic pole position sensor. Select PM Vector control with speed and pole position sensor (F42 = 16)

The tuning result is automatically written to the relevant parameter.



### 3 Preparing the mechanical system

As preparation for performing rotation tuning, remove machine couplings, and disable safety interlocks.

### 4 Execution of auto-tuning

- 1) Set one of 1, 2 or 4 to parameter P04, and press the  key. 1, 2 and 4 blink slowly.

Parameter No.	Function name	Data	Default data	Unit
P04	1st Auto Tuning Function Selection	1: Tune the motor parameters while stopped 2: Tune the motor parameters while rotating 4: Tune the PM motor magnetic pole position offset while rotating	0	-

- 2) Input the RUN command. In the factory default state, forward rotation is performed when the  key is pressed in an enabled state. To perform reverse rotation or when the RUN command is input via the FW or RV terminals, change the setting of F02.
- 3) When the RUN command is input, 1, 2 and 4 light and tuning is started with operation stopped. The time required for auto-tuning is approx. 5 to 40 seconds.
- 4) After (3) above is completed when P04 = 2, acceleration is performed up to 50% of the rated speed and rotation tuning is started. When rotation tuning is completed, a deceleration stop is performed. The time required for this operation is 10 seconds excluding the acceleration/deceleration time.
- 5) When the RUN command via the FW and RV terminals is selected according to the F02 = 1 setting, tuning is completed when  is displayed. Turn the RUN command OFF. When the RUN command was input via the touch panel or via communication, the RUN command is shut off automatically as soon as tuning is completed.
- 6) When tuning is completed, the following parameter No. is displayed.

## 5 Corrective action in case of an error

As unwanted tuning might cause hunting or other malfunctions or worsen operational accuracy, the inverter generates Er7 and discards tuning values when an abnormality is found in the tuning result.

When tuning ends in an error (Er7), check the following.



- Is inverter output wiring open?
- Has the mechanical brake operated?
- Has the free-run command "FRS" turned ON?
- Are parameter settings correct?









For details on the tuning error (Er7), refer to *Tuning Error* on page 6-69.

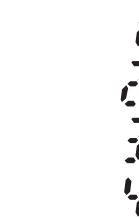

## Tuning Error

The following table summarizes the causes of tuning errors.

Sub codes can be displayed in the alarm information display (monitor mode 6\_21). To display a sub code, press the Enter key when an alarm is displayed and select 6\_21. Individual alarms are displayed in addition to the following alarms when regular alarm detection is activated.

Cause of tuning error	 Error sub code	Cause and countermeasure
Sequence abnormality		When RUN command OFF, forced stop "STOP" and free-run stop "FRS," etc. are input during tuning →Do not turn the RUN command OFF during tuning.
Overcurrent abnormality		When an abnormally large current flows during tuning →Check the state of the mechanical brake. Also, check if the motor can be mechanically rotated.

Cause of tuning error	Error sub code	Cause and countermeasure
Tuning result abnormality		When unbalance between phases or an output phase loss is detected, or when an open output, etc. causes the tuning result to be an abnormally large or small value →Check the wiring.
Tuning frequency abnormality (Only when P04 = 2)		When various limit operations occur during tuning, or when a limit is applied at the maximum output frequency or frequency limiter (upper limit) →Change so that the limit value becomes 50% or higher of the base frequency.
Error occurrence		When an insufficient voltage state has occurred or an alarm has occurred →For details on countermeasures for individual alarms, refer to 9-1 Alarm Display and Remedies on page 9-2.
Acceleration time exceeded (Only when P04 = 2)		When 3x the set value of acceleration time in F07 is exceeded for the output frequency to reach 50% of the base frequency →Increase the value of F07.
Control method error		Although the motor is rotated for magnetic pole position tuning when P30 = 0 or 3, when P04 = 1: Tune the motor parameters while stopped is performed at this setting When P04 = 5: Tune the motor %R1 and %X while stopped is performed when F42 = 15 is set →Set to the correct combination.
Parameter Setting error		When the rated impedance or rated inductance is outside the effective range →Check setting of F04, F05 and P03
Inability to calculate magnetic pole position		When P30 = 1 or 3 is set: When the salient pole ratio of the motor inductance is small When P30 = 2 is set: When there is no magnetic saturation characteristic of the motor →When P30 = 1, change P87 to a small value. Note, however, that in the case of motors that are difficult to magnetically saturate, tuning is sometimes impossible. →When P30 = 2 or 3, set P30 = 0, and adjust while increasing F24 in stages in increments between about 0.5 to 5.0 s until rotation tuning no longer fails.
Insufficient magnetic saturation		When the magnetic saturation characteristic of the motor is small and the magnetic pole position cannot be distinguished →Increase the value of P87 in stages taking about 120% as the upper limit. When there is no apparent effect, set P30 = 0 or 3, and set to about F24 = 0.5 to 5.0 s.
Excessive magnetic saturation		When the magnetic saturation characteristic of the motor is large, and a large current flows for distinguishing the magnetic pole position, which is dangerous →Set P87 to a small value.

Cause of tuning error	Error sub code	Cause and countermeasure
Tuning result abnormality	 Error sub code  { 	When unbalance between phases or a phase loss is detected, or when an open output or short-circuit causes the tuning result to be abnormally small or large →Check that there is no error occurring in the wiring between the inverter and motor. →When there is an electromagnetic contactor (MC) between the inverter and motor, check to see if the contact is open.

## 6-8-2 Online Tuning

When dynamic torque vector control or slip compensation control is adopted and operation is performed for a long time, motor constants change according to the rise in motor temperature. When motor constants change, the speed compensation amount of the motor changes, and this sometimes results in the motor speed deviating from the initial motor rotation speed. By enabling online tuning, the motor constants corresponding to the change in motor temperature are identified and fluctuation in motor speed is reduced.

Online tuning can be used in either of the following cases after having performed rotation tuning by auto-tuning.

- When 1st Drive Control Selection (F42)/2nd Drive Control Selection (A14) is set to “1: IM Dynamic torque vector control”
- When 1st Drive Control Selection (F42)/2nd Drive Control Selection (A14) is set to “0: IM V/f control,” and Slip compensation Function Selection (H442) is set to “1: Valid” and 1st Torque Boost Function Selection (E112)/2nd Torque Boost Function Selection (E113) is set to “1: Automatic torque boost”

Parameter No.	Function name	Data	Default data	Unit
P05/A19	1st Online Tuning Function Selection/2nd Online tuning Function Selection	0: Disable 1: Enable	0	-

# 6-9 Brake Control Function

The 3G3M1 Series Inverter has a built-in brake control function for an elevating system, for example. Use this function to control the external brake used in an elevating system, for example, from the inverter.

The brake control function can be used independently of the 1st Drive Control Selection (F42)/2nd Drive Control Selection (A14) setting.

## 6-9-1 Operation Sequence of Brake Control Function

The description of operation sequence of brake control function is shown below.

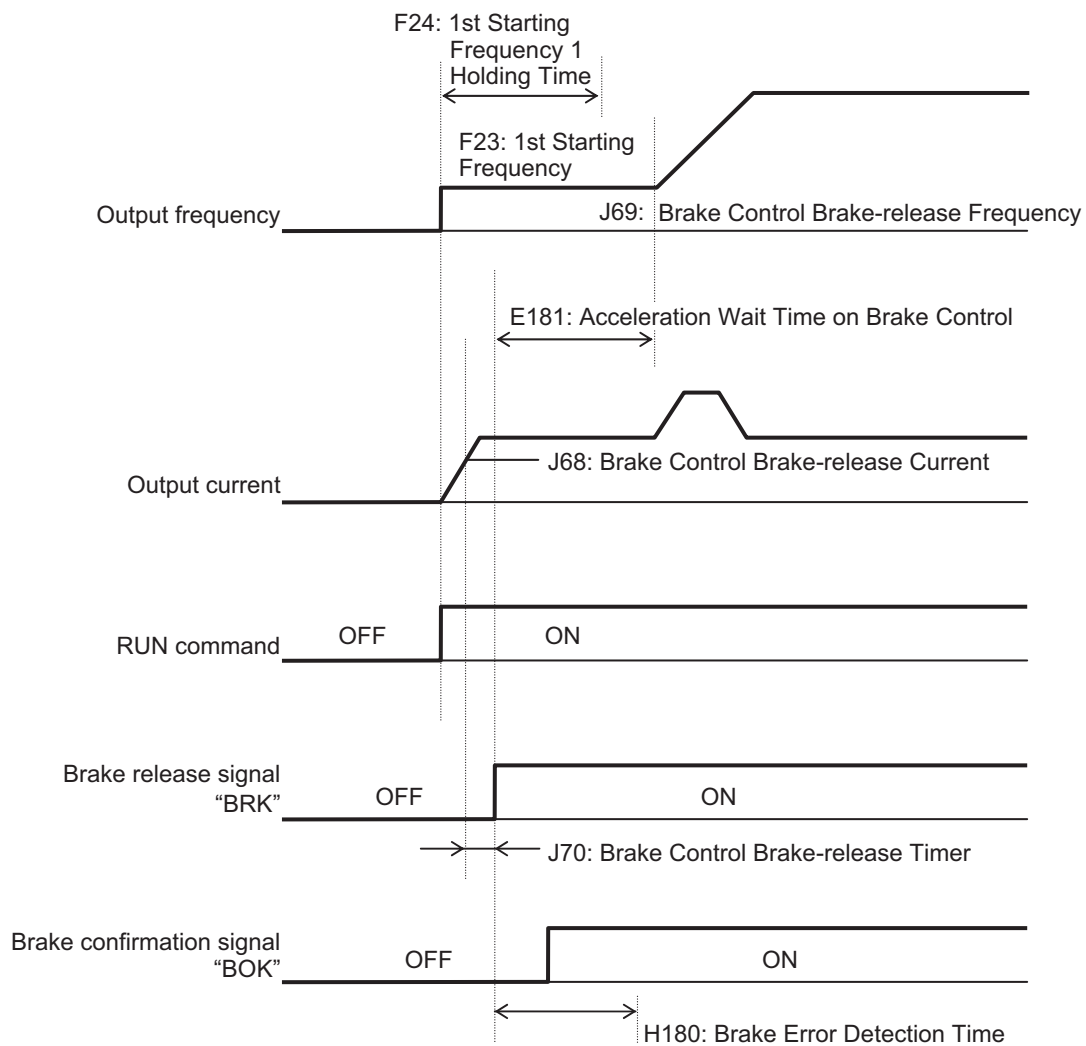

V/f control Operation time chart at startup

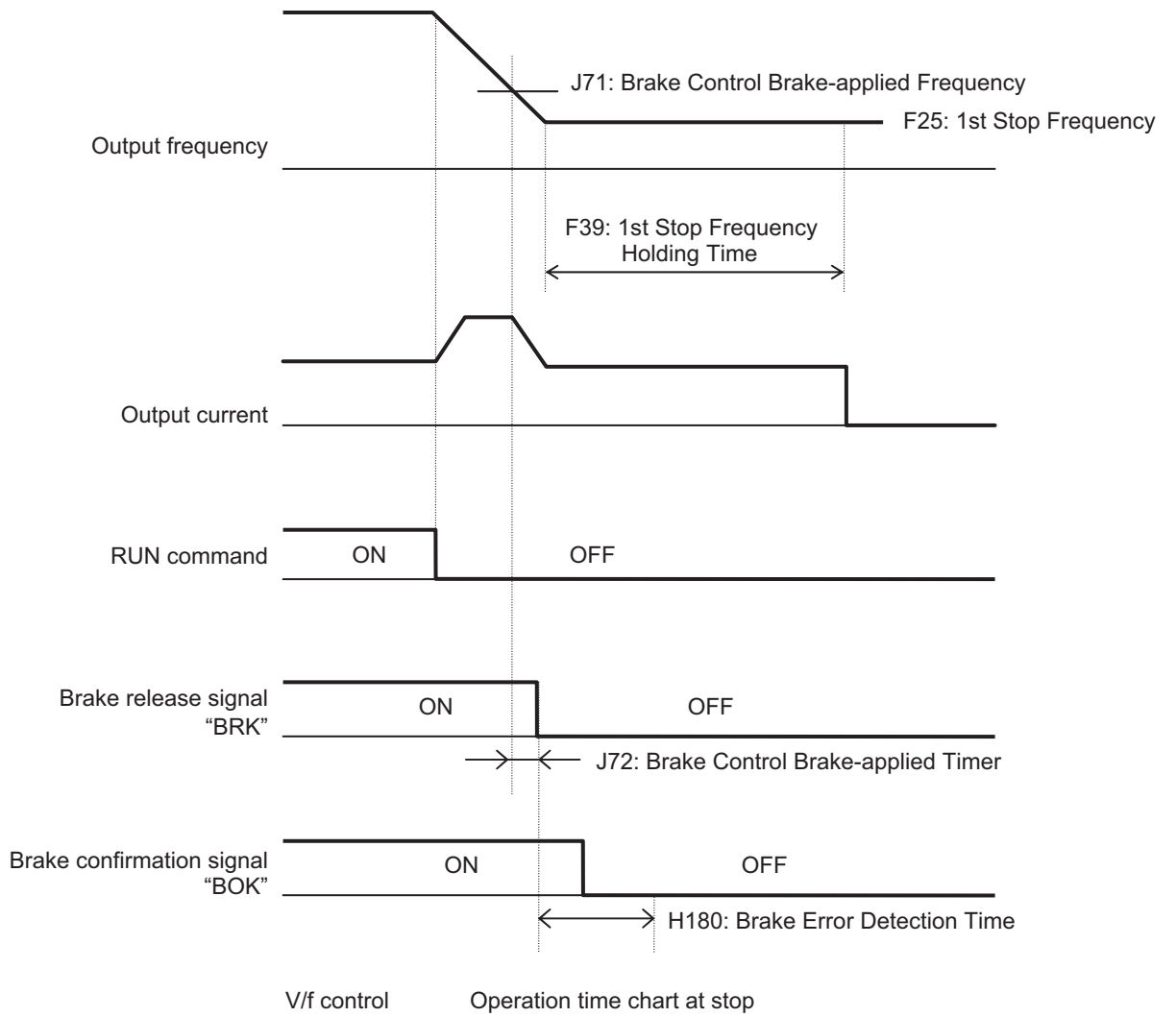

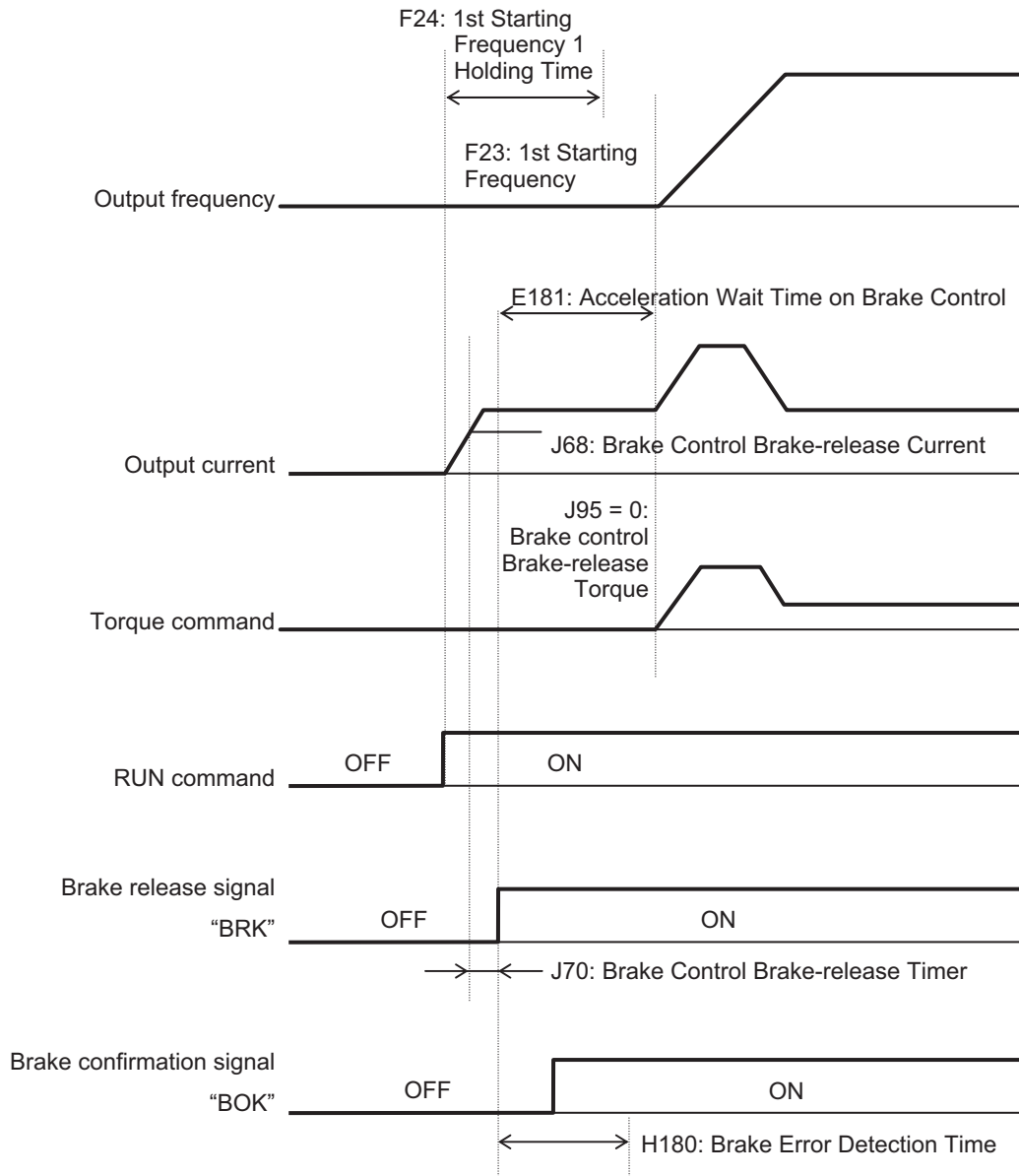

Vector control    Operation time chart at startup



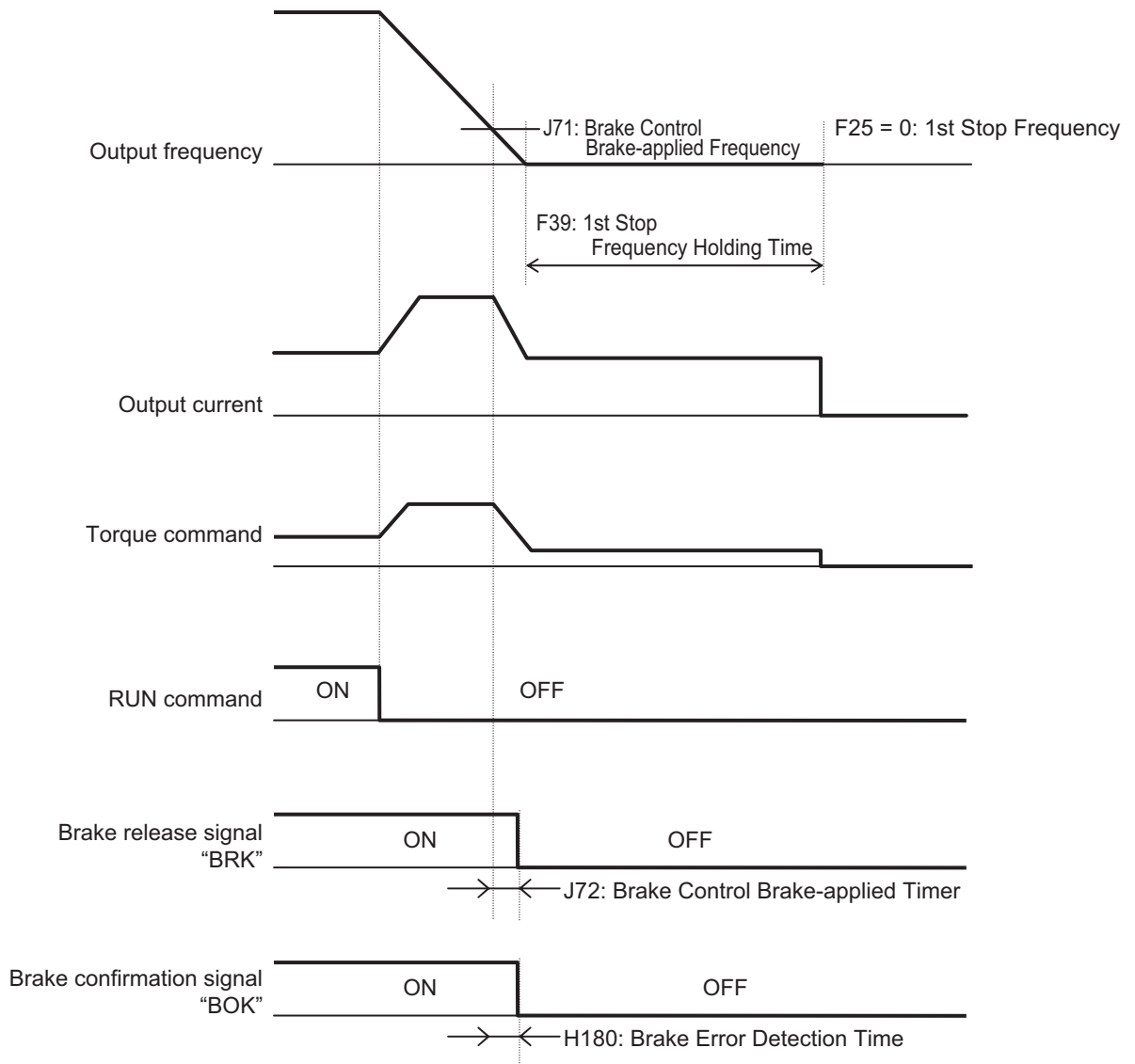

Vector control Operation time chart at stop

**Note** The above sequence chart shows an example where one of Input Terminal [DI1] Function Selection to Input Terminal [DI7] Function Selection (E01 to E05, E98, E99) is set to "65: BOK (brake confirmation signal)."

### ● At acceleration

1. When the RUN command is input, the inverter starts output.
2. When both the output current and output frequency (in V/f control) and the output current and torque command (in vector control) reach the brake signal release level (J68, J69, J95), the inverter waits for the time set at Brake Control Brake-release Timer (J70) and then outputs the brake release signal (E20, E21, E27 = 57: BRK).
3. After the brake release signal is output, the inverter waits for input of the brake confirmation signal (E01 to E05, E98, E99 = 65: BOK) for the time set at Brake Error Detection Time (H180). If the brake confirmation signal is not input within the time set at H180, the inverter sets the output terminal and outputs the brake error signal (E20, E21, E27 = 182: BER) and detects the brake error (Er6).

- After the brake release signal is input (brake is released), the inverter waits for the time set at Acceleration Wait Time on Brake Control (E181), and performs acceleration again up to the set frequency.

### ● At deceleration

- When the RUN command turns OFF, the inverter decelerates to the Brake Control Brake-applied Frequency (J71), waits for the time set at Brake Control Brake-applied Timer (J72), and turns OFF the brake release signal (E20, E21, E27 = 57: BRK).
- After the brake release signal is turned OFF, the inverter waits for the brake confirmation signal (E01 to E05, E98, E99 = 65: BOK) for the time set at Brake Error Detection Time (H180) to turn OFF.

If the brake confirmation signal does not turn OFF within the time set at H180, the inverter outputs the brake error signal (E20, E21, E27 = 182: BER) and detects the brake error (Er6).

- After the brake confirmation signal turns OFF (after applying the brake), when the inverter arrives at the stop frequency, it waits for the time set at 1st Stop Frequency Holding Time (F39) and decelerates again to an output frequency of 0 Hz.

## 6-9-2 Brake Control Function Settings

To enable the brake control function, allocate “57: BRK (brake release)” to the multifunction output terminal.

The brake control function can be used independently of the 1st Drive Control Selection (F42)/2nd Drive Control Selection (A14) setting.

In the 3G3M1 Series, you can combine this function with the position control.

For details on how to combine this function with position control, refer to *6-7-15 Brake Control during Position Control* on page 6-58.

- Allocate the following output to Output Terminal [DO1] Function Selection (E20), Output Terminal [DO2] Function Selection (E21) or Output Terminal [ROA, ROB] Function Selection (E27).

Brake control output : “57: BRK (brake release)”

Brake error output : “182: BER (brake error)”

- As required, allocate “65: BOK (brake confirmation)” to Input Terminal [DI1] Function Selection to Input Terminal [DI7] Function Selection (E01 to E05, E98, E99) to use this function.
- According to your system, set the parameters used for the operation sequence.
- To generate high torque at startup, it is recommended to use the torque bias function. For details on the torque bias function, refer to *6-6-2 Torque Bias Function Settings* on page 6-33.
- Set a frequency higher than Brake Control Brake-release Frequency (J69). If the set frequency is equal to or lower than the J69 value, the inverter will detect an overload because the brake cannot be released.

Parameter No.	Function name	Data	Default data	Unit
J70	Brake Control Brake-release Timer	0.000 to 5.000	1.000	s
E181	Acceleration Wait Time on Brake Control	0.00 to 5.00	0.00	s
F39	1st Stop Frequency Holding Time	0.00 to 10.00	0.00	s

Parameter No.	Function name	Data	Default data	Unit
H180	Brake Error Detection Time	0.00 to 10.00	1.00	s
J69	Brake Control Brake-release Frequency <sup>*1</sup>	0.0 to 25.0	1.0	Hz
J68	Brake Control Brake-release Current <sup>*2</sup>	0.00 to 300.00 Set the motor rated torque as 100%.	100.00	%
J71	Brake Control Brake-applied Frequency <sup>*1</sup>	0.0 to 25.0	1.0	Hz
J72	Brake Control Brake-applied Timer	0.000 to 5.000	1.000	Hz
J95	Brake control Brake-release Torque	0.00 to 300.00 Set the motor rated torque as 100%.	100.00	%
J96	Brake Control Operation Selection	0 to 31 (Decimal) (Enabled only in vector control with speed sensor)	0	-
	bit 0: Target operation speed	0: Speed detection value	0	-
		1: Speed command value		
		Selection of speed information used for braking judgment		
	bit 4: Braking condition selection	0: RUN command OFF disabled	0	-
1: RUN command OFF enabled				
bit 6: Operation selection during position control stop	0: BRK OFF	0	-	
	1: BRK ON			
E01 to E05, E98, E99	Input Terminal [DI1] Function Selection to Input Terminal [DI7] Function Selection	65: BOK (brake confirmation)	-	-
E20, E21	Output Terminal [DO1] Function Selection, Output Terminal [DO2] Function Selection	57: BRK (brake release)	-	-
E27	Output Terminal [ROA, ROB] Function Selection	182: BER (brake error)		

\*1. Set this to a value larger than 1st Starting Frequency (F23).

\*2. Note that, if the set value is too low, the inverter may not output a sufficient torque when the brake is released.

## 6-10 Application Control

In winding systems such as wire drawing machines and spinning machines, the outer diameter of the wind-up roll increases due to the amount of material being wound onto the roll and the actual wind-up speed increases when winding is continued at a constant shaft speed. To maintain the wind-up speed at the outer periphery at a constant speed, a speed sensor is used to detect the wind-up speed, and the speed of the motor shaft is controlled so that the wind-up speed is kept constant.

### 6-10-1 Application Control Settings

Set enable/disable status for line speed control and synchronized run operation (simultaneous start synchronization/standby synchronization).

Parameter No.	Function name	Data	Default data	Unit
d41	Special Control Selection	1: Line speed control with speed sensor	0	-
d15	Input Terminal [PIA][PIB] Encoder Pulse Resolution	20 to 60000	1024	Pulse
d16	Input Terminal [PIA][PIB] Pulse Scaling Factor Denominator	1 to 32767	1	-
d17	Input Terminal [PIA][PIB] Pulse Scaling Factor Numerator	1 to 32767	1	-
E01 to E05, E98, E99	Input Terminal [DI1] Function Selection to Input Terminal [DI7] Function Selection	70: Line speed control cancellation 71: Line speed control frequency memory	-	-

### Machine Configuration and Settings

The following parameters must be set when the mechanical system of a winder is configured as shown in the figure below.

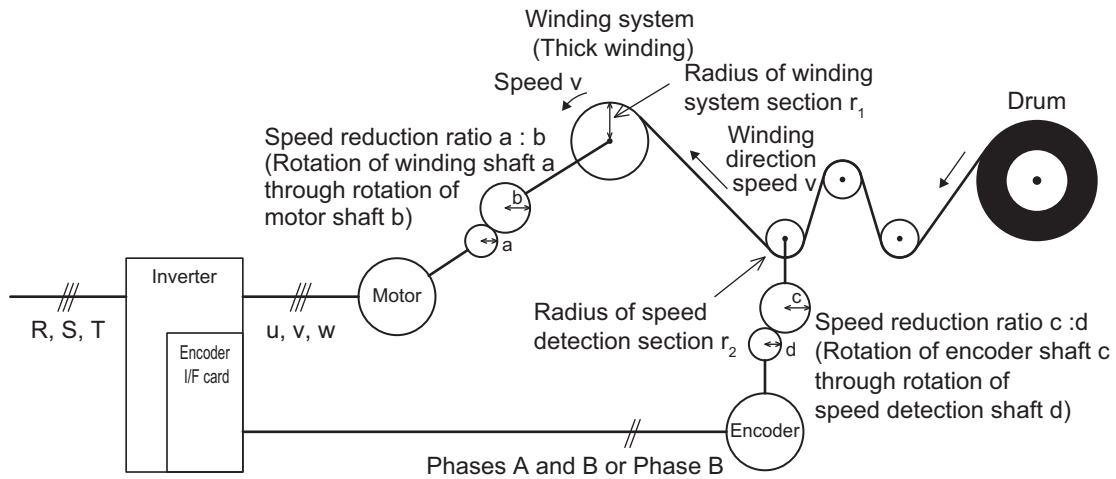

- Speed reduction ratio of motor shaft to winding shaft:  $a:b$
- Speed reduction ratio of speed detection shaft to encoder shaft:  $c:d$
- Radius of winding system section before winding:  $r_1$  [m]
- Radius of speed detection section:  $r_2$  [m]

Parameter No.	Function name	Description
d15	Input Terminal [PIA][PIB] Encoder Pulse Resolution	Set the number of encoder pulses in hexadecimal [P/R]
d16	Input Terminal [PIA][PIB] Pulse Scaling Factor Denominator	Speed reduction ratio of overall mechanical system
d17	Input Terminal [PIA][PIB] Pulse Scaling Factor Numerator	Set denominator coefficient ( $K_1 = r_1 \times a \times c$ ) of d16 = speed reduction ratio Set numerator coefficient ( $K_2 = r_2 \times b \times d$ ) of d17 = speed reduction ratio

$$\frac{K_2}{K_1} = \frac{r_2}{r_1} \times \frac{b}{a} \times \frac{d}{c} = d17/d16$$

## Canceling Line Speed Control

Line speed control can be canceled by the “Hz/LSC” signal. When line speed control is canceled, frequency compensation by PI arithmetic calculation is set to zero. As a result, thick winding compensation is no longer carried out and winding speed increases. Use this feature to temporarily stop control, for example, to correct thread breakage.

Hz/LSC	Function
OFF	Line speed control enabled (According to d41)
ON	Line speed control canceled (V/f control, thick winding compensation OFF)

## Line Speed Control Frequency Memory

The frequency reference that was executed can be saved to memory. By doing so, startup is performed from the saved frequency at a restart so that the peripheral speed is kept constant.

LSC-HLD	Function
OFF	Disabled (save operation not performed)
ON	Enabled (frequency reference after thick winding compensation is saved)

## Digital Setting

Set as follows to set the peripheral speed (feed speed) digitally in m/min.

Parameter No.	Function name	Description
E48	Operator Display Speed Monitor Item Selection	5: Feed speed
E50	1st Frequency Conversion Coefficient	$K_s = \frac{240\pi \times a \times r_1}{p \times b}$ <p> <math>K_s</math> : 1st Frequency Conversion Coefficient (E50)  <math>p</math> : Number of motor poles  <math>a, b</math> : Motor shaft - Winding shaft speed reduction ratio (Rotation of winding shaft a occurs when the motor shaft b rotates)  <math>r_1</math> : Radius of winding system (Initial value before winding) (m) </p>

## Analog Setting

To set the peripheral speed (feed speed) by analog input, set analog input (0% to 100%) by the following formula.

$$\text{Analog input (\%)} = \frac{p \times b \times 100}{240\pi \times r_1 \times a \times f_{\max}} \times V$$

V: Peripheral speed (line speed) (m/min),  $f_{\max}$ : 1st Maximum Output Frequency (F03)

## Adjustment

Just like regular speed control, the speed command filter, speed detection filter, P gain, integral time, and other parameters of the speed control system that controls peripheral speed to a constant speed must be adjusted.

Parameter No.	Function name	Description
d01	Speed Control 1 Speed Command Filter	Increase the filter constant when overshooting in response to changes in the speed command is large.
d02	Speed Control 1 Speed Detection Filter	Set a large filter constant to increase gain when the speed detection signal contains ripple and the gain of speed control cannot be raised.
d03	Speed Control 1 P Proportional Gain	When running a motor at a speed in which hunting occurs, lower the gain. When response is slow, increase the gain.
d04	Speed Control 1 I Integral Time	When response is slow, shorten the integral time.

# 6-11 Torque Limit Function

## 6-11-1 Torque Limit Function Settings

The torque limit function is for limiting the output torque of the motor.

- With the torque limit function, the following torque limit values are applied according to torque limit switching 1 and 2, analog voltage/current input and operation state allocated to 1st Drive Control Selection (F42)/2nd Drive Control Selection (A14), Torque Limit Operation Selection (H75) and multifunction input.

Control Method	Torque Limit Operation Selection H75	Multi-function Input		Analog input	Operation state	Torque limit value to be applied
		TRQ1	TRQ2			
V/f control	-	OFF	-	Available*1	Power running*2	Analog input
				Not available	Regeneration*2	
		ON	-	Power running	F40	
				Regeneration	F41	
Vector control	0: Four quadrants independent	-	-	Available	1st quadrant	Analog input
				Not available	2nd quadrant	F40
				-	3rd quadrant	F41
				-	4th quadrant	E16
	1: Four quadrants identical	OFF	OFF	Available	-	Analog input
				Not available	-	F40
				ON	OFF	F41
				OFF	ON	E16
		ON	ON	-	E17	

\*1. To enable analog input, set "7: Analog torque limiter" to one of Input Terminal [AI1] Function Selection (E61), Input Terminal [AI2] Function Selection (AII) (E62) or Input Terminal [AI2] Function Selection (AIV) (E63).

\*2. Power running indicates the 1st and 3rd quadrants, and regeneration indicates the 2nd and 4th quadrants.

- Setting "184: TL (torque limit enabled)" to Input Terminal [DI1] Function Selection to Input Terminal [DI7] Function Selection (E01 to E05, E98, E99) enables the torque limit function only when the TL is input.

When this terminal is reset, the torque limit setting is disabled and the inverter uses the maximum value (300%) as the torque limit value.

When the torque limit enabled (TL) function is not allocated to a multifunction input terminal, the torque limit function is enabled at all times.

- The torque limit function regards the motor rated torque as 100%.
- When “132: TRQ (Torque limited)” is set to Output Terminal [DO1] Function Selection (E20), Output Terminal [DO2] Function Selection (E21) or Output Terminal [ROA, ROB] Function Selection (E27), the torque limit function can be checked to see if it is activated by the status of the torque limited signal.
- To enable the torque limit value by analog input or current input, set “7: Analog torque limiter” to one of Input Terminal [AI1] Function Selection (E61), Input Terminal [AI2] Function Selection (AII) (E62) or Input Terminal [AI2] Function Selection (AIV) (E63). Analog inputs 0 to 10 V or 4 to 20 mA (0 to 20 mA) are equivalent to torque limit values 0% to 300%. The torque limit value set by analog input is enabled in all operation modes.

Parameter No.	Function name	Data	Default data	Unit
F40	Torque Limit 1 (power running)	0 to 300 (In four quadrants, forward driving)	300	%
F41	Torque Limit 2 (regeneration)	0 to 300 (In four quadrants, reverse regeneration)		
E16	Torque Limit 3 (power running)	0 to 300 (In four quadrants, reverse driving)		
E17	Torque Limit 4 (regeneration)	0 to 300 (In four quadrants, forward regeneration)		
E01 to E05, E98, E99	Input Terminal [DI1] Function Selection to Input Terminal [DI7] Function Selection	14: TRQ1 (Torque limit switching 1) 184: TL (Torque control enabled) 185: TRQ2 (Torque limit switching 2)	-	-
E20, E21	Output Terminal [DO1] Function Selection, Output Terminal [DO2] Function Selection	132: TRQ (Torque limited)	-	-
E27	Output Terminal [ROA, ROB] Function Selection			
E61 E62 E63	Input Terminal [AI1] Function Selection Input Terminal [AI2] Function Selection (AII) Input Terminal [AI2] Function Selection (AIV)	7: Analog torque limiter	-	-
H74	Torque Limit Function Selection	0: Torque limit 1: Torque current limit	1	-
H75	Torque Limit Operation Selection	0: Four quadrants independent 1: Four quadrants identical	0	-
H76	Frequency Rising Limit for Torque Limit	0.0 to 590.0	5.0	Hz



### ● Details of Four Quadrant Independent (H75 = 0)

The torque limit when “0: Four quadrant independent” is selected at Torque Limit Operation Selection (H75) (F40, F41, E16 and E17) is as shown in the figure below.

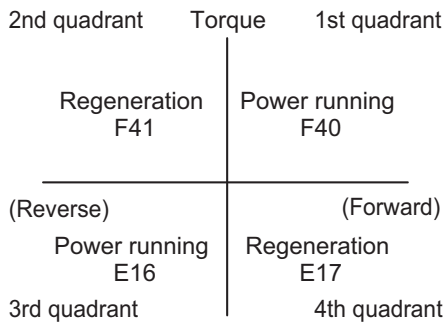

### ● Details of Four Quadrant Identical (H75 = 1)

When “1: Four quadrants identical” is selected at Torque Limit Operation Selection (H75), the torque limit value (F40, F41, E16 and E17) that is switched by torque limit switching 1 and 2 allocated to multifunction input terminals is set as shown in the figure below.

Exam- When torque limit switching 1 (14: TRQ1) is allocated to multifunction input terminal DI1 and torque limit switching 2 (185: TRQ2) is allocated to multifunction input terminal DI2

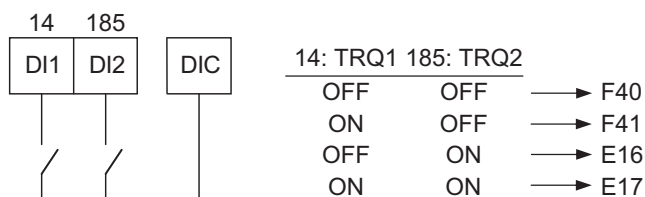

### ● Details of Torque Limiter (H74 = 0)

This parameter limits the torque to a fixed value.

### ● Details of Frequency Rising Limit for Torque Limit (H76)

When a load is applied on the regeneration side, the actual speed of the motor is pulled to the load side to become faster than the output frequency of the inverter. When this state continues, the voltage at both ends of the main circuit capacity rises, and an overvoltage is detected and results in the inverter tripping. To avoid a trip, the overvoltage is averted by increasing the output frequency to more than the actual frequency reference. However, at this time, this torque limiter functions to apply a limit to how far the frequency rises.

## 6-11-2 Torque Monitor

In the torque calculation value of V/f control and the torque command value in vector control, the torque polarity is generally + for drive and - for braking. When the rotational direction changes from forward rotation to reverse rotation in elevator loads or similar applications, the polarity also is reversed as torque changes from drive to braking.

When Sysmac Studio is connected to trace torque data, continuous data can no longer be acquired as the polarity of the torque command value also changes interlocked with the speed polarity. The continuity of torque data can be ensured as forward drive and reverse braking is handled as + polarity and

forward braking and reverse drive is handled as - polarity by setting 0 to Torque Command Monitor Polarity Selection (E49).

Parameter No.	Function name	Data	Default data	Unit
E49	Torque Command Monitor Polarity Selection	0: Torque polarity 1: Plus for driving Minus for braking	1	-

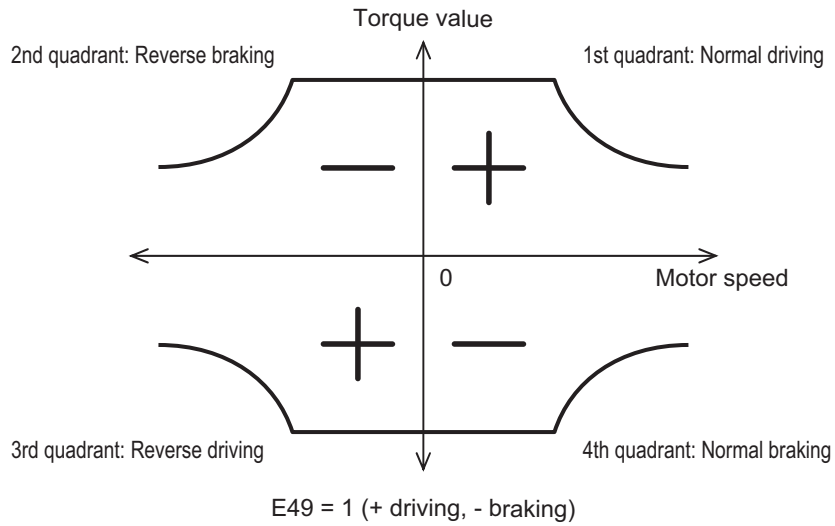
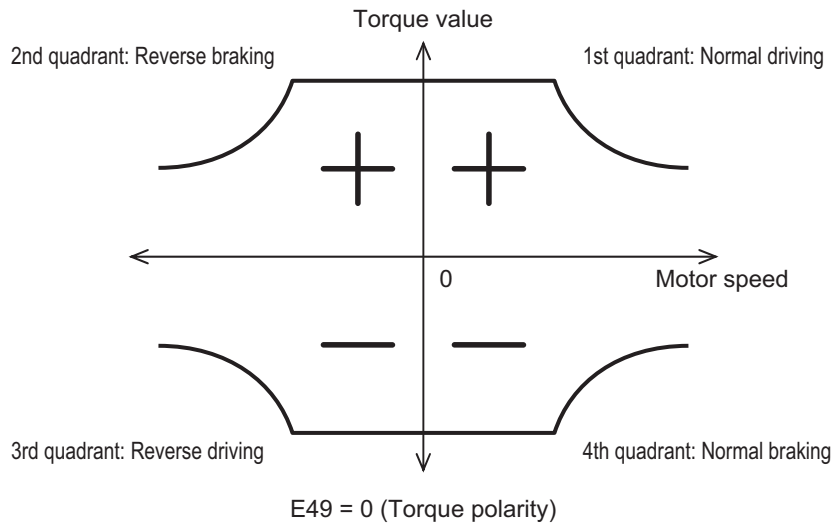

## 6-12 Overtorque/Undertorque Function

### 6-12-1 Overtorque/Undertorque Function Settings

Use this function to detect that the estimated motor output torque value exceeded the set level and output the overtorque signal.

- To enable detection of the overtorque state, allocated “46: OTQ (Over/under torque signal) (NO contact)” to Output Terminal [DO1] Function Selection (E20), Output Terminal [DO2] Function Selection (E21) or Output Terminal [ROA, ROB] Function Selection (E27). Detection of the undertorque state also can be enabled by allocating “1046: OTQ (Over/under torque signal) (NC contact).”
- The overtorque/undertorque ON signal is output when the torque value calculated by the inverter or the torque command value is at the set level of torque detection (operation level) or higher, and continues for the set time of torque command detection (timer time) or longer. The overtorque/undertorque signal is turned OFF when the torque calculation value becomes “operation level - 5% of the motor rated torque or lower.”
- The operation level can be set separately to each of the four quadrants, and the state at acceleration/deceleration and constant speed also can be selected.
- For calculating the overtorque and undertorque levels in this function, the motor rated torque is taken to be 100%.
- Use this function to detect the brake release signal of an elevator, or if the load applied to the load machine is abnormally high.

Parameter No.	Function name	Data	Default data	Unit
E20, E21	Output Terminal [DO1] Function Selection, Output Terminal [DO2] Function Selection	46: OTQ (Overtorque) 1046: OTQ (Undertorque)	-	-
E27	Output Terminal [ROA, ROB] Function Selection			
E78	Overtorque/Undertorque Detection Level at Forward Power Running			
E80	Overtorque/Undertorque Detection Level at Reverse Regeneration	0 to 300	100	%
E196	Overtorque/Undertorque Detection Level Reverse Power Running	0 to 300	100	%
E197	Overtorque/Undertorque Detection Level Forward Regeneration	0 to 300	100	%
E79	Torque detection 1 Detection Timer	0.01 to 600.00	10.00	s
E198	Overtorque/Undertorque Detection Condition Selection	0: Output during acceleration/deceleration and constant-speed operation 1: Output only during constant-speed operation	1	s

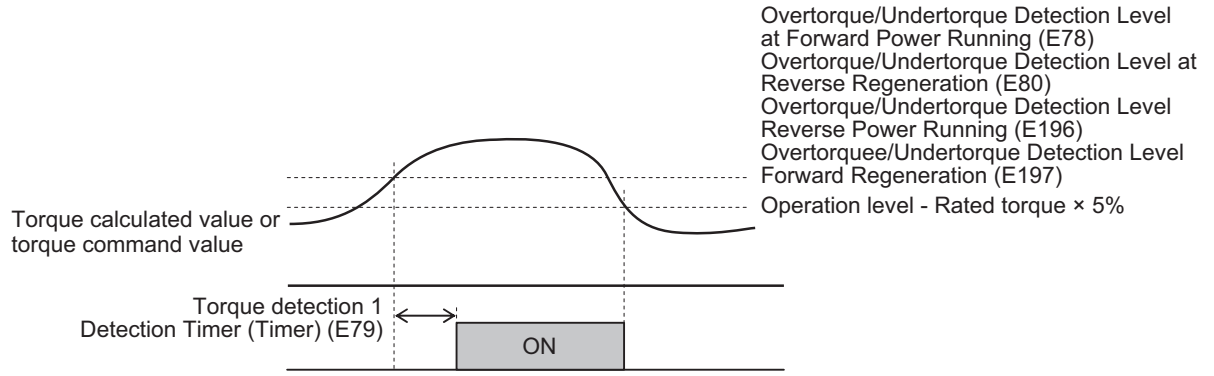

# 7

## Other Functions

This section describes the details of functions not described in Section 5 or Section 6.

<b>7-1</b>	<b>Status Monitors .....</b>	<b>7-3</b>
7-1-1	Operation Monitor .....	7-3
7-1-2	I/O check .....	7-11
7-1-3	Maintenance Information .....	7-13
7-1-4	Alarm information .....	7-18
<b>7-2</b>	<b>Multifunction Input/Output Functions List.....</b>	<b>7-26</b>
7-2-1	Multifunction Input Selection .....	7-26
7-2-2	Multifunction Output Selection.....	7-31
<b>7-3</b>	<b>Analog I/O Settings .....</b>	<b>7-35</b>
7-3-1	Analog Input Function Selection.....	7-35
7-3-2	Analog Input Adjustment Function .....	7-38
7-3-3	Analog Input Filter .....	7-45
7-3-4	Analog Command Hold Function (AHD) .....	7-45
7-3-5	Analog Output Function Selection.....	7-46
7-3-6	Analog Output Adjustment Function.....	7-48
<b>7-4</b>	<b>Restart Functions.....</b>	<b>7-49</b>
7-4-1	Restart Settings.....	7-49
7-4-2	Restart after Momentary Power Failure .....	7-49
7-4-3	Trip Retry Operation .....	7-58
7-4-4	Unattended Start Protection (USP Terminal).....	7-59
7-4-5	Free Run Restart.....	7-60
<b>7-5</b>	<b>DC Injection Braking Function.....</b>	<b>7-63</b>
7-5-1	DC Injection Braking (DB) .....	7-63
<b>7-6</b>	<b>Safety Function .....</b>	<b>7-69</b>
7-6-1	Overview of Safety Function .....	7-69
7-6-2	Safety Function Settings .....	7-69
7-6-3	Wiring Safety Function for Use.....	7-70
<b>7-7</b>	<b>Digital Operator and Operation Functions.....</b>	<b>7-74</b>
7-7-1	Soft Lock Function (SFT) .....	7-74
7-7-2	Forced Operator Function (OPE) .....	7-75
7-7-3	Forced Terminal Block Function (F-TM).....	7-75
7-7-4	Initial Screen Selection.....	7-76
7-7-5	Password Function.....	7-77
7-7-6	User Parameter Setting Function .....	7-80
7-7-7	STOP Key Priority/Start Check Function.....	7-80

<b>7-8</b>	<b>Functions Related to Protection, Warning and Various Output Signals.....</b>	<b>7-82</b>
7-8-1	Current Limit/Overload Prevention Control/Overload Warning.....	7-82
7-8-2	Anti-regenerative Control Function.....	7-85
7-8-3	Instantaneous Overcurrent Limitation .....	7-87
7-8-4	External Trip (EXT).....	7-87
7-8-5	Thermistor Trip Function .....	7-88
7-8-6	Frequency Arrival Signal (FAR1 to 3, FDT1 to 4, FAR1FDT1).....	7-89
7-8-7	Power ON Time Over/RUN Time (ONT/RNT) .....	7-92
7-8-8	Maintenance monitor .....	7-93
7-8-9	Logic Operation Output Signal (LOG1 to LOG3).....	7-94
7-8-10	Capacitor Life Warning Signal (WAC) .....	7-96
7-8-11	Braking Transistor Broken (DBAL) .....	7-98
7-8-12	Cooling FAN Control Method Selection.....	7-99
7-8-13	Cooling Fan Life Warning Signal (WAF).....	7-99
7-8-14	Lifetime Alarm (LIFE) .....	7-100
7-8-15	Communications Disconnection Detection Signal (NDc) .....	7-101
7-8-16	Starting Contact Signal (FR) .....	7-101
7-8-17	Cooling Fin Overheat Warning (OHF) .....	7-102
7-8-18	Low Current Signal (LOC) .....	7-102
7-8-19	Window Comparator/Disconnection Detection (AI1Dc/AI2Dc/AIVDc).....	7-103
7-8-20	Frequency Reference Selection Status Signal (FREF).....	7-105
7-8-21	RUN Command Status Signal (REF) .....	7-105
7-8-22	2nd control under selection signal (SETM, SWM1).....	7-105
7-8-23	Inverter Output Limiting (IOL, IOL2) .....	7-106
7-8-24	Low-To-Moderate Voltage Detection (U-EDC) .....	7-106
7-8-25	AX Terminal Function (AX) .....	7-107
7-8-26	Light Alarm Selection .....	7-108
7-8-27	Input Phase Loss Protection / Output Phase Loss Protection.....	7-111
7-8-28	Clearing of Integrated Power (KHC).....	7-112
<b>7-9</b>	<b>Other Operation Functions.....</b>	<b>7-113</b>
7-9-1	Carrier Frequency .....	7-113
7-9-2	Automatic Carrier Frequency Reduction .....	7-114
7-9-3	Starting Frequency and Stop Frequency.....	7-114
7-9-4	Zero Speed Control .....	7-115
7-9-5	Frequency Jump Function .....	7-116
7-9-6	RUN Direction Limit Selection .....	7-117
7-9-7	Permission of RUN Command .....	7-117
7-9-8	Frequency Calculation Function .....	7-118
7-9-9	Frequency Addition Function.....	7-118
7-9-10	UP/DOWN control .....	7-119
7-9-11	AVR (Automatic Voltage Regulator) Function .....	7-121
7-9-12	Overexcitation Control during Deceleration.....	7-122
7-9-13	PID Function.....	7-123
7-9-14	Automatic Energy-saving Operation Function.....	7-141
7-9-15	Commercial Switching (CS) .....	7-141
7-9-16	Output current fluctuation damping .....	7-144
7-9-17	Pulse Train Frequency Input .....	7-145
7-9-18	LAD Cancel Function .....	7-148
7-9-19	Servo Lock Function.....	7-148
7-9-20	Droop Control .....	7-149
7-9-21	Magnetic Flux Level at Light Load.....	7-150
7-9-22	Pre-excitation .....	7-151
7-9-23	Forced Stop.....	7-152
7-9-24	Overload Stop Function.....	7-153
7-9-25	Battery Operation Enable Command (BATRY) .....	7-155
7-9-26	Universal Terminal.....	7-155
7-9-27	Protection/Maintenance Mode Selection Function .....	7-157

## 7-1 Status Monitors

This section describes the output frequency, fault monitor during trip, and other monitor functions of the inverter.

### 7-1-1 Operation Monitor

Item No.	Parameter No.	Item	Range	Display item
3_00	W03	Output Frequency Monitor before Slip Compensation	0.00 to 590.00 [Hz]	Output frequency 1 (before slip compensation) is displayed in increments of 0.01 Hz.
3_01	W115	Output Frequency After Slip Compensation	0.00 to 590.00 [Hz]	Output frequency 2 (after slip compensation) is displayed in increments of 0.01 Hz.
3_02	W05	Output Current Monitor	0.00 to 655.3 [A]	Output current effective value is displayed in increments of 0.01 A. A current value of 100 A or higher is displayed in increments of 0.1 A.
3_03	W06	Output Voltage Monitor	0.0 to 999.0 [V]	The output voltage command value is displayed in increments of 0.1 V. However, the display value changes in increments of 1.0 V.
3_04	W07	Output Torque Monitor	-400 to 400 [%]	The torque calculated value, torque command value and torque current command value are displayed in increments of 1%. <ul style="list-style-type: none"> <li>Rated motor torque ratio of torque calculated value in the case of V/f control and dynamic torque vector control</li> <li>Speed control mode of vector control: Rated motor torque ratio of speed control output (after torque bias)</li> <li>When the torque command is used in the torque control mode of vector control: Rated motor torque ratio of torque command value</li> <li>When the torque current command is used in the torque control mode of vector control: Rated motor current ratio of torque current command value</li> </ul>
3_05	W02	Frequency Reference Monitor	0.00 to 590.00 [Hz]	Displays the set frequency in increments of 0.01 Hz and 100 Hz.

Item No.	Parameter No.	Item	Range	Display item
3_06	-	Operation direction		<p>The output operation direction is displayed. "F: Forward" or "r: Reverse" is displayed, and "---" is displayed when stopped.</p> <p>The rotation direction is determined according to the polarity of the output frequency. During vector control, it is determined according to the detection speed.</p> <p>*Generally, as seen from the axial direction, the forward rotation of the motor is in the counterclockwise direction.</p>
3_07	W01	Running Status 1 Monitor	0000Hex to FFFFHex	<p>The operation status is displayed by a four-digit hexadecimal.</p> <p>0000 to FFFF hex</p> <p>Bit15: BUSY (During Parameter code data writing)</p> <p>Bit14: -</p> <p>Bit13: -</p> <p>Bit12: RL (Communications effective)</p> <p>Bit11: ALM (Alarm relay)</p> <p>Bit10: DEC (During deceleration)</p> <p>Bit9: ACC (During acceleration)</p> <p>Bit8: IL (During current limiting)</p> <p>Bit7: VL (During voltage limiting)</p> <p>Bit6: TL (Torque limiting)</p> <p>Bit5: NUV (Main circuit DC voltage established)</p> <p>Bit4: BRK (During braking)</p> <p>Bit3: INT (Inverter shut down)</p> <p>Bit2: EXT (During DC braking or during pre-exciting)</p> <p>Bit1: REV (During reverse operation)</p> <p>Bit0: FWD (During forward operation)</p>



Item No.	Parameter No.	Item	Range	Display item
3_08	W110	Motor Speed	0.00 to 9999 [r/min] 1000 to 9999 [10r/min]	<p>The rotation speed is displayed as "output frequency (Hz) × 120/ Number of motor poles".</p> <p>If the monitor value is 10000 or above, the x10 LED lights up and the value of "monitor value/10" is displayed.</p> <ul style="list-style-type: none"> <li>• Value converted from the V/f control and frequency before dynamic torque vector control slip compensation based on the number of poles</li> <li>• V/f with speed sensor, vector with speed sensor: Motor speed detection value</li> <li>• Vector without speed sensor: Motor rotation speed estimated value</li> </ul>
3_09	W111	Load Shaft Speed	0.00 to 9999 [r/min] 1000 to 9999 [10r/min]	<p>The load speed is calculated by multiplying the output frequency by (1st Frequency Conversion Coefficient (E50) / Display Coefficient 1 for Transport Time / Auxiliary Display Coefficient 1 for Speed Monitor (E39)) and displayed.</p> <p>Load speed = Output frequency × (E50 / E39)</p> <p>If the monitor value is 10000 or above, the x10 LED lights up and the value of "monitor value/10" is displayed.</p>
3_10	W11	PID Process Command	-999 to 9990	<p>The PID command value is converted using PID Control Maximum Scale (J106) and PID Control Minimum Scale (J107) and displayed.</p> <p>Display value = (PID process command (%)/100) × (Display maximum value - Display minimum value) + Display minimum value</p> <p>If PID control is disabled, "-----" is displayed.</p>

Item No.	Parameter No.	Item	Range	Display item
3_11	W12	PID Feedback Value Monitor	-999 to 9990	<p>The PID feedback value is converted using PID Control Maximum Scale (J106) and PID Control Minimum Scale (J107) and displayed.</p> <p>Display value = (PID feedback value (%) / 100) × (Display maximum value - Display minimum value) + Display minimum value</p> <p>If PID control is disabled, "-----" is displayed.</p> <p>Even when "----" is displayed for 3_11, W12 displays the input PID feedback value.</p>
3_12	W13	Torque Limit Value A Monitor	-300 to 300 [%]	<p>The selected torque limit set value of the rated motor torque ratio is displayed in increments of 1%. During V/f control, the power running torque limit is displayed in A and the regenerative torque limit is displayed in B.</p> <p>During vector control and four quadrants independent (H75 = 0), the 1st/3rd quadrant torque limit is displayed in A and the 2nd/4th quadrant torque limit is displayed in B. 1st and 3rd, and 2nd and 4th are switched depending on forward rotation or reverse rotation.</p> <p>During vector control and four quadrants identical (H75 = 1), the same value is displayed in A and B.</p> <p>The torque limit is selected by the torque limit function. (Reference: 6-11 Torque Limit Function on page 6-81)</p>
3_13	W14	Torque Limit Value B Monitor		
3_14	W15	Ratio value Monitor	0.00 to 200.0 [%]	<p>A ratio set value of 1.00 time selected via analog input is displayed as 100%.</p> <p>If the ratio set value is not selected, "-----" is displayed.</p> <p>Even when "----" is displayed for 3_14, W15 displays the input ratio set value.</p>

Item No.	Parameter No.	Item	Range	Display item
3_15	W10	Feed Speed	0.00 to 9999 [m/min] 1000 to 9999 [10 m/min]	The feed speed is calculated by multiplying the output frequency by (1st Frequency Conversion Coefficient (E50) / Display Coefficient 1 for Transport Time / Auxiliary Display Coefficient 1 for Speed Monitor (E39)) and displayed. Feed speed = Output frequency × (E50 / E39) If the display value is 10000 or above, the x10 LED lights up and the value of display value/10 is displayed.
<b>When position control is enabled (When DI terminal SPD is not allocated)</b>				
3_17	W144, W145	Target Position Monitor (MSB), Target Position Monitor (LSB)		The target position user value (hexadecimal) is displayed alternately in upper bytes/lower bytes.
3_18	W142, W143	Feedback Current Position Monitor (MSB), Feedback Current Position Monitor (LSB)	F000 0000 hex to 0FFF FFFF hex (Hexadecimal) (Equivalent to -268435456 to 268435455)	The current position is displayed alternately in upper bytes/lower bytes.
3_19	W146, W147	Position Deviation Monitor (MSB), Position Deviation Monitor (LSB)		The position deviation is displayed alternately in upper bytes/lower bytes.
3_20	W152	Touch Probe Status	0000 hex to FFFF hex (Hexadecimal)	bit 0: Touch probe 1 Enb bit 1: Touch probe 1 PLc bit 8: Touch probe 2 Enb bit 9: Touch probe 2 PLc Other than the above: Reserved
<b>When position control is enabled (When DI terminal SPD is allocated)</b>				
3_17	-	Reserved	-	-
3_18	-	Reserved	-	-
3_19	-	Reserved	-	-
3_20	-	Reserved	-	-
3_21	W32	PID Output Monitor	-150 to -99.9, 9.99 to 99.99, 100.0 to 150.0 [%]	The PID output value is displayed in increments of 0.01%. (The maximum frequency is 100%.) If PID control is disabled, "----" is displayed. 0 is displayed in W32.

Item No.	Parameter No.	Item	Range	Display item
3_22	W26	Magnetic Flux Command Value	0 to 999 [%]	<p>The flux command value is displayed in increments of 1%. The magnetic flux command calculated by vector control is displayed. 0 is displayed for other than vector control.</p> <p>In the case of an induction motor (IM), the magnetic flux that is generated when a current equivalent to the no-load current flows is displayed on the monitor as 100%.</p> <p>In the case of a synchronous motor (PM), the magnetic flux equivalent to the PM Motor Induced Voltage (P63) is displayed on the monitor as 100%.</p>
3_23	M74	Running Status 2 Monitor	0000Hex to FFFFHex	<p>The operation status is displayed by a four-digit hexadecimal. 0000 to FFFF hex</p> <p>Bit15: Motor type (1: PM motor / 0: Induction motor)</p> <p>Bit14: During EN circuit diagnosis</p> <p>Bit7: During speed control (1 during control)</p> <p>Bit5 Bit4: Select motor</p> <p>00: 1st motor 01: 2nd motor 10: Reserved 11: Reserved</p> <p>Bit3 to 0: Control method</p> <p>0000: V/f control without slip compensation 0001: Dynamic torque vector control 0010: V/f control with slip compensation 0011: V/f control with speed sensor 0100: Dynamic torque vector control with speed sensor 0101: Vector control without speed sensor 0110: Vector control with speed sensor 0111: Torque control (Vector control without speed sensor) 1000: Torque control (Vector control with speed sensor)</p>
3_25	-	Reserved	-	-
3_29	W116	PG Feedback Value	0.00 to 590.0 [Hz]	The value obtained by converting the PG feedback value to frequency is displayed in Hz.

Item No.	Parameter No.	Item	Range	Display item
3_32	W118	Torque Bias Monitor	-999 to 999	Displays the torque bias command value selected by Torque Bias Function Selection (H154), Select torque bias 1 (60: TB1) terminal or Select torque bias 2 (61: TB2) terminal. (Displayed in % with respect to the rated motor torque)
3_50	W153	Pulse Input Rate for A/B Phase of Reference Side	-327 to -99.9 to -9.99 to 99.99 to 327.6 [p/s]	The pulse rate entered in the AB phase of the PG used as the input function selection command (reference) side is displayed. (in increments of 0.01 [kp/s])
3_51	W154	Pulse Input Rate for Z Phase of Reference Side	0 to 9999 [p/s] 1000 to 1600 [10p/s]	The pulse rate entered in the Z phase of the PG used as the input function selection command (reference) side is displayed. If the monitor value is 10000 or above, the x10 LED lights up and the value of "monitor value/10" is displayed.
3_52	W155	Pulse Input Rate for A/B Phase of Feedback Side	-327 to -99.9 to -9.99 to 99.99 to 327.6 [kp/s]	The pulse rate entered in the AB phase of the PG used as the return (follower) side is displayed. (in increments of 0.01 [kp/s])
3_53	W156	Pulse Input Rate for Z Phase of Feedback Side	0 to 9999 [p/s] 1000 to 1600 [10p/s]	The pulse rate entered in the Z phase of the PG used as the return (follower) side is displayed. If the monitor value is 10000 or above, the x10 LED lights up and the value of "monitor value/10" is displayed.

## Running Status 1 Monitor [3\_07]

The operation status displays the status allocated to each bit by a four-digit hexadecimal.

The allocation for 0 to 15 bits of the operation status is described in the table below.

Bit	Symbol	Description
15	BUSY	Parameter data is being written
14	WR	Fixed to 0
13		Fixed to 0
12	RL	Communications effective (the condition when the RUN command is issued from communication, or when the set frequency is referenced (When Modbus coil spec. No. 001C hex RL (communication is enabled) is 1))
11	ALM	Alarm occurrence
10	DEC	During deceleration
9	ACC	During acceleration
8	IL	During current limiting
7	VL	During voltage limiting

Bit	Symbol	Description
6	TL	Torque limiting
5	NUV	Main Circuit DC Voltage > Undervoltage level
4	BRK	During braking
3	INT	Inverter output is being intercepted
2	EXT	During DC braking
1	REV	During reverse rotation
0	FWD	During forward rotation

Display example of operation status																
Hexadecimal LED monitor	<div style="display: flex; justify-content: space-around; align-items: center;"> <div style="text-align: center;">LED4</div> <div style="text-align: center;">LED3</div> <div style="text-align: center;">LED2</div> <div style="text-align: center;">LED1</div> </div> 															
LED No.	LED4				LED3				LED2				LED1			
Bit	15	14	13	12	11	10	9	8	7	6	5	4	3	2	1	0
Binary	1	0	0	0	0	0	1	1	0	0	1	0	0	0	0	1

## Running Status 2 Monitor [3\_23]



The operation status 2 displays the status allocated to each bit by a four-digit hexadecimal.

The allocation for 0 to 15 bits of the operation status is described in the table below.

The display of operation status 2 is the same as that of “3\_07: Operation status” monitor.

Bit	Symbol	Description
15	-	Synchronous motor drive
14	-	During EN circuit diagnosis
13	-	Not used
12	-	
11	-	
10	-	
9	-	
8	-	
7	-	1, during speed limitation (torque control)
6	-	Not used
5	-	Motor selection
4	-	00: 1st motor 01: 2nd motor
3	-	Control Method
2	-	0000: V/f control without slip compensation
1	-	0001: Dynamic torque vector control
0	-	0010: V/f control with slip compensation 0011: V/f control with speed sensor 0100: Dynamic torque vector control with speed sensor 0101: Vector control without speed sensor 0110: Vector control with speed sensor 1011: Torque control (Vector control with speed sensor)

## 7-1-2 I/O check

Item No.	Parameter No.	Item	Range	Display contents (The value range depends on the model)
4_00	W40, W41	Input Terminal Monitor, Output Signal Monitor		Displays the ON/OFF status of the input terminals [DI1] to [DI7], output terminals [DO1], [DI2], [ROA, ROB] and the [EN1] and [EN2] terminals.
4_01	W42, W43	Communications Input Signal Monitor, Communications Control Output Signal Monitor		Displays the ON/OFF status of the input terminals [DI1] to [DI7], [EN1], [EN2], RST (reset command), REV (reverse command), FWD (forward command) and the output terminals [DO1], [DO2], [ROA, ROB] instructed via communication based on RS-485.
4_02	W44	Input Terminal [AI1] Input Voltage	0.0 to 12.0 [V]	The input voltage of the analog input terminal [AI1] is displayed in increments of 0.1 V.
4_03	W45	Input Terminal [AI2] All Input Current (All)	0.0 to 30.0 [mA]	The input current of the analog input terminal [AI2] (All) is displayed in increments of 0.1 mA. *Since this item is shared with other terminal functions, "0.0" is displayed when it is disabled due to switching by the hardware SW.
4_04	W46	Output Terminal [AO] AOV Output Voltage	0.0 to 12.0 [V]	The output voltage of analog output terminal [AO] (AOV) is displayed in increments of 0.1 V.
4_06	W48	Output Terminal [AO] PO Output Frequency	0 to 9999 [p/s] 1000 to 3200 [10p/s]	The number of output pulses per unit time of analog output terminal [AO] (PO) is displayed in (p/s). If the monitor value is 10000 or above, the x10 LED lights up and the value of "monitor value/10" is displayed.
4_07	W49	Input Terminal [AI2] Input Voltage (AIV)	0.0 to 12.0 [V]	The input voltage of analog input terminal [AI2] (AIV) is displayed in increments of 0.1 V. *Since this item is shared with other terminal functions, "0.0" is displayed when it is disabled due to switching by the hardware SW.
4_08	W50	Terminal [AO] (AOI) output current	0.0 to 30.0 [mA]	The output current of analog output terminal [AO] (AOI) is displayed in increments of 0.1 mA. *Since this item is shared with other terminal functions, "999" is displayed when it is disabled due to switching by the hardware SW.
4_15	W53	Reserved	-	-
4_16	W54	Reserved	-	-
4_17	W55	Pulse Input (A/B Phase [PIA][PIB])	-327 to -99.9 to -9.99 to 99.99 to 327.6 [kp/s]	The pulse rate entered in the pulse input terminal [PIA] [PIB] is displayed. (in increments of 0.01 [kp/s]) Displayed without quad edge evaluation regardless of the pulse format.

Item No.	Parameter No.	Item	Range	Display contents (The value range depends on the model)
4_18	W56	Pulse Input (Z Phase [PIZ])	0 to 9999 [p/s] 1000 to 1600 [10p/s]	The pulse rate entered in the pulse input terminal [PIZ] is displayed. If the monitor value is 10000 or above, the x10 LED lights up and the value of "monitor value/10" is displayed.
4_24	X90	Reserved	-	-
4_36	X97	Input Input Terminal [PTC] Input Voltage	-12.0 to 12.0 [V]	The thermistor input terminal [PTC] input voltage is displayed in increments of 0.1 V. *Since this item is shared with other terminal functions, "999" is displayed when it is disabled due to switching by the hardware SW.

## Digital Input/Output Terminal Monitor [4\_00]

This function displays the ON/OFF status of the input/output signal of the digital input/output terminal. The monitor displays the input/output status of the terminals depending on whether each segment of the LED is ON or OFF.

The allocation of each segment and the input/output signal is described in the table below.

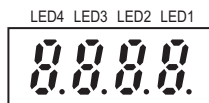

Segment	LED4	LED3	LED2	LED1
a	ROA, ROB	DO1	-	DI6
b	-	DO2	-	DI7
c	-	-	-	DI1
d	-	-	EN1 ([SF1] terminal)	DI2
e	-	-	EN2 ([SF2] terminal)	DI3
f	-	-	-	DI4

## Communications Control Signal (Input/Output) Monitor [4\_01]

The ON/OFF status of the digital input/output terminal instructed via communication based on RS-485 is displayed.

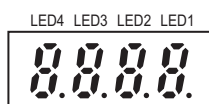

Segment	LED4	LED3	LED2	LED1
a	ROA, ROB	DO1	-	FW
b	-	DO2	-	RV
c	-	-	-	DI1
d	-	-	-	DI2
e	-	-	-	DI3
f	-	-	DI6	DI4
g	-	-	DI7	DI5
dp	-	-	RST	-



## 7-1-3 Maintenance Information

Item No.	Parameter No.	Item	Range	Display item
5_00	W70	Total Power ON Time Monitor	0 to 655350 hours	The cumulative operation time (the time when the main power supply is ON) of the inverter is displayed. Measurement range: 0 to 655,350 hours Display: The cumulative operation time is displayed alternately in the upper digits and lower digits. Example 0 <=> 535h (535 hours) 655 <=> 350h (655,350 hours) When the lower three digits are displayed, an h (hours) is displayed in the lowermost digit. When 655,350 hours is reached, it is considered as the upper limit.
5_01	W71	Main circuit DC voltage Monitor	0.0 to 999.0 [V]	The Main Circuit DC Voltage of the inverter is displayed. Although the display is in increments of 0.1 V, the data changes in increments of 1 V.
5_02	W72	Internal Air Highest Temperature	20 to 125 [°C]	The maximum value of the internal air temperature for each hour is displayed in increments of 1 degree. Display unit: °C (for 20°C and below, 20°C is displayed.) Since there is no internal air temperature sensor in 15kW and lower models, "----" is displayed. 0 is displayed in W72.
5_03	W73	Heat Sink Maximum Temperature	20 to 125 [°C]	The maximum value of the cooling fin temperature for each hour is displayed. Display unit: °C (for 20°C and below, 20°C is displayed.)
5_04	W74	Maximum Effective Current Value	0.00 to 99.99 [A] 100.0 to 999.9 [A]	The maximum effective current value for each hour is displayed. Display unit: Displayed in increments of 0.01 A for 100 A or below, and in increments of 0.1 A for above 100 A
5_05	W75	Main Circuit Capacitor's Capacitor Monitor	0.0 to 100.0 [%]	The factory default value of the current main circuit capacitor's capacitor is displayed as 100.0%.

Item No.	Parameter No.	Item	Range	Display item
5_06	W67	Cumulative Run Time of Capacitors on Printed Circuit Boards	0 to 9999 [x10h]	<p>The time obtained by multiplying the coefficient based on the ambient temperature conditions with the cumulative time during which voltage is applied to the electrolytic capacitors on printed circuit boards is displayed as the cumulative operation time.</p> <p>Measurement range: 0 to 99,990 hours Display: 0 to 9999 x10 LED lit (Cumulative run time of capacitors on printed circuit boards = Display × 10 hours)</p> <p>If 99,990 hours is exceeded, the accumulation operation stops, and the display remains as 9999.</p> <p>For details, refer to <i>7-8-10 Capacitor Life Warning Signal (WAC)</i> on page 7-96.</p>
5_07	W68	Cumulative Run Time of Cooling Fan	0 to 9999 [x10h]	<p>The cumulative time when the cooling fan was operating is displayed.</p> <p>Counting is not performed when the ON/OFF control effective (parameter H06) is enabled, and the cooling fan has stopped.</p> <p>Measurement range: 0 to 99,990 hours Display: 0 to 9999 x10 LED lit (Cumulative run time of cooling fan = Display × 10 hours)</p> <p>If 99,990 hours is exceeded, the accumulation operation stops, and the display remains as 9999.</p>
5_08	W78	Number of Startups	0 to 9999 1000 to 6553 [x10 LED]	<p>The number of operations of the 1st motor (number of times the RUN command for the inverter is turned ON) is calculated and displayed. If the number of operations becomes 10,000 or more, the x10 LED lights up and the value of "Number of operations/10" is displayed. If 65,530 operations is exceeded, the value returns to 0 and the calculation continues.</p>
5_09	W81	Integrated Power Monitor	0.000 to 9999 [100 kWh]	<p>The integrating electric power consumption is displayed. 0.1 kWh to 999,900 kWh is displayed for 0.001 to 9999, with 1 = 100 kWh. The value returns to 0 at 1,000,000 kWh.</p> <p>The integrated electric power consumption and the integrated electric power data can be reset by setting Display Coefficient for Integrated Power (E51) to "0.000." If 999,900 kWh is exceeded, the value returns to 0. Integration is not performed when 0.000 is still set.</p>

Item No.	Parameter No.	Item	Range	Display item
5_10	W82	Data Used Integrating Electric Power	0.001 to 9999	<p>The integrated electric power consumption (1.000 = 100 kWh) × Display Coefficient for Integrated Power (E51) is displayed as the integrated electric power data.</p> <p>The setting range of Display Coefficient for Integrated Power (E51) is 0.000 to 9999.</p> <p>Display unit: None</p> <p>If 9999 is exceeded, the display remains as 9999.</p> <p>The decimal point position moves depending on the size of the integrating electric power data, and the display resolution changes. The integrating electric power data can be reset by setting parameter E51 to "0.000." Integration is not performed when 0.000 is still set.</p>
5_11	W83	Number of Operator Comm Errors	0 to 9999 [errors]	The number of errors after turning ON the power is accumulated and displayed. If the number of errors exceeds 9,999, the value returns to 0.
5_12	W84	Contents of Operator Comm error	0 to 127	The latest errors that occur in the Digital Operator are displayed in a decimal code.
5_13	W95	Reserved	-	-
5_14	W87	Inverter ROM Version 1 Main	x.xx.xx	x.xx (upper three digits) and xx (lower two digits) are displayed alternately.
5_15	W88	Inverter ROM Version 2 Sub	x.xx.xx	x.xx (upper three digits) and xx (lower two digits) are displayed alternately.
5_16	W89	ROM Version Operator	0 to 9999	The version of the Operator is displayed.
5_17	W85	Number of RS-485 Errors	0 to 9999	If the cumulative value of the number of errors after turning ON the power reaches 9999, the value returns to 0.
5_18	W94	Contents of RS-485 Error	0 to 127	The error code of the final communication error that has occurred in the SP-SN terminal is displayed in hexadecimal.
5_19	-	-	-	-
5_23	Z40	1st Cumulative Run Time	0 to 9999 [x10h]	<p>The cumulative time of the 1st motor run time is displayed.</p> <p>Measurement range: 0 to 99,990 hours (Cumulative operation time of motor = Display × 10 hours)</p> <p>If 99,990 hours is exceeded, the value returns to 0 and the calculation continues.</p>

Item No.	Parameter No.	Item	Range	Display item
5_24	M61	Inverter Internal Air Temperature Monitor	20.0 to 125.0 [°C]	The current internal temperature of the inverter is displayed. Although the display is in increments of 0.1°C, the data changes in increments of 1°C. Display unit: °C Since there is no internal air temperature sensor in 15 kW and lower models, "-----" is displayed. 0 is displayed in M61.
5_25	M62	Fin Temperature Monitor	20.0 to 125.0 [°C]	The current temperature of the cooling fin inside the inverter is displayed. Although the display is in increments of 0.1°C, the data changes in increments of 1°C. Display unit: °C
5_26	M76	Service Life of Main Circuit Capacitor Elapsed Time	0 to 6553 [10h]	The time during which voltage is applied to the electrolytic capacitor of the main circuit is displayed as the cumulative elapsed time. The capacity of the electrolytic capacitor of the main circuit is measured when the main power supply is OFF, and the elapsed time is corrected. x10_LED always ON The upper limit is reached at 9999
5_27	M77	Service Life of Main Circuit Capacitor Remaining Time	0 to 6553 [10h]	The time remaining until the service life of the electrolytic capacitor of the main circuit is displayed. x10_LED always ON
5_28	Z41	2nd Cumulative Run Time of motor	0 to 9999 [x10h]	The cumulative time of the 2nd motor run time is displayed.
5_31	M81	1st Remaining Time before the Next Motor Maintenance	0 to 9999 [x10h]	The time until the next maintenance is displayed. The value obtained by subtracting the cumulative motor run time from 1st Motor Maintenance Interval (H78) is displayed. (This function is available only for the 1st motor) Display: 0 to 99990
5_32	Z44	2nd Number of Start-ups	0 to 9999 1000 to 6553 [x10 LED]	The number of operations of the 2nd motor (number of times the RUN command for the inverter is turned ON) is calculated and displayed. If the monitor value is 10000 or above, the x10 LED lights up and the value of "monitor value/10" is displayed.

Item No.	Parameter No.	Item	Range	Display item
5_35	M85	1st Remaining Start-up Times before the Next Motor Maintenance	0 to 9999 1000 to 6553 [x10 LED]	The number of startups until the next maintenance is displayed. The value obtained by subtracting the number of startups from 1st Preset Startup Count for Motor Maintenance (H79) is displayed. (This function is available only for the 1st motor) If the monitor value is 10000 or above, the x10 LED lights up and the value of "monitor value/10" is displayed.
5_36	M86	Latest Light Alarm Factor	00 hex to FF hex	The contents of the minor alarm that occurred recently, the last to third last time are displayed by a code. 0 to 254 (00 hex to FE hex) 0 (0x00 Hex): No alarm 17 (0x11 Hex): OH1 Heat sink overheat 18 (0x12 Hex): OH2 External alarm input 19 (0x13 Hex): OH3 Inverter internal overheat 22 (0x16 Hex): dbH Braking resistor overheat 23 (0x17 Hex): OL1 Motor 1 overload 24 (0x18 Hex): OL2 Motor 2 overload 34 (0x22 Hex): Er4 Option card communications error 35 (0x23 Hex): Er5 Option card error 47 (0x2F Hex): ErE Following error (excessive speed deviation) 53 (0x35 Hex): ErP RS-485 communications error (Option card) 56 (0x38 Hex): Ero Position control error 58 (0x3A Hex): CoF PID feedback disconnection detected 100 (0x64 Hex): FAL Detect DC fan lock 101 (0x65 Hex): OL Motor overload early warning 102 (0x66 Hex): OH Heat sink overheat early warning 103 (0x67 Hex): LiF Lifetime alarm 104 (0x68 Hex): rEF Reference loss 105 (0x69 Hex): Pid PID alarm 106 (0x6A Hex): UTL Low output torque detection 107 (0x6B Hex): PTC PTC thermistor activated 108 (0x6C Hex): rTE Inverter life (Cumulative run time) 109 (0x6D Hex): CnT (Inverter life, Number of startups)
5_37	M87	Light Alarm Factor Last		
5_38	M88	Light Alarm Factor 2nd Last		
5_39	M89	Light Alarm Factor 3rd Last		
5_40	-	-	-	-

Item No.	Parameter No.	Item	Range	Display item
5_54	W161	Braking Resistor Thermal Monitor	0.0 to 100.0%	The percentage of the electronic thermal calculated value for motor protection at the current moment is displayed. If the percentage reaches 100.0%, the dBH alarm occurs.
5_62	M59	Motor Electronic Thermal Monitor	0.0 to 100.0%	The percentage of the electronic thermal calculated value for motor protection at the current moment is displayed. If the percentage reaches 100.0%, the OL1 (1st motor overload) or OL2 (2nd motor overload) (depending on whether the 1st control or 2nd control is selected) occurs.
5_63	W179	Total RUN Time Monitor	0 to 655350 hours	The cumulative time of the inverter RUN state is displayed. Measurement range: 0 to 655,350 hours Display: The cumulative operation time is displayed alternately in the upper digits and lower digits. Example 0 <=> 535h (535 hours) 655 <=> 350h (655,350 hours) When the lower three digits are displayed, an h (hours) is displayed in the lowermost digit. If 655,350 hours is reached, the display remains as 655350.

#### 7-1-4 Alarm information

Item No.	Parameter No.	Item	Range	Description
<b>1 Latest alarm</b>				
6_00	X20	Latest Alarm Info. Output Frequency	0.00 to 99.99, 100.0 to 590.0 [Hz]	The output frequency before slip compensation is displayed in increments of 0.01 Hz. A value of 100.0 Hz or higher is displayed in increments of 0.1 Hz.
6_01	X21	Latest Alarm Info. Output Current	0.00 to 99.99, 100.0 to 655.3 [A]	The output current is displayed. A current value of 100.0A or higher is displayed in increments of 0.1 A. Display unit: A (Ampere)
6_02	X22	Latest Alarm Info. Output Voltage	0 to 999 [V]	The output voltage is displayed. Display unit: V (Volt)
6_03	X23	Latest Alarm Info. Torque Monitor	-400 to 400 [%]	The torque calculated value is displayed.
6_04	X24	Latest Alarm Info. Frequency Command	0.00 to 99.99, 100.0 to 590.0 [Hz]	The set frequency is displayed.
6_05	X25	Latest Alarm Info. Running Status 1	F/r/----	The output operation direction is displayed.

Item No.	Parameter No.	Item	Range	Description
6_06	X25	Latest Alarm Info. Running Status 1	0000Hex to FFFFHex	The operation status is displayed by a four-digit hexadecimal. 0000 to FFFF hex Bit15: BUSY (During function code data writing) Bit14: - Bit13: - Bit12: RL (Communications effective) Bit11: ALM (Alarm relay) Bit10: DEC (During deceleration) Bit9: ACC (During acceleration) Bit8: IL (During current limiting) Bit7: VL (During voltage limiting) Bit6: TL (Torque limiting) Bit5: NUV (Main circuit DC voltage established) Bit4: BRK (During braking) Bit3: INT (Inverter shut down) Bit2: EXT (During DC braking or during pre-exciting) Bit1: REV (During reverse operation) Bit0: FWD (During forward operation)
6_07	X26	Latest Alarm Info. Cumulative Ope. time	0 to 655,350 hours	The cumulative inverter run time (the time when the main power supply is ON) when an error occurs is displayed. It is displayed alternately in the upper digits and lower digits. When the lower three digits are displayed, an h (hours) is displayed in the lowermost digit.
6_08	X27	Latest Alarm Info. Number of Startups	0 to 9999 1000 to 6553 [x10 LED]	The number of operations of the motor selected when an alarm occurred (number of times the RUN command for the inverter is turned ON) is calculated and displayed. If the monitor value is 10000 or above, the x10 LED lights up and the value of "monitor value/10" is displayed.
6_09	X28	Latest Alarm Info. Main Circuit DC Voltage	0.0 to 999.0 [V]	The Main Circuit DC Voltage of the inverter is displayed.
6_10	X29	Latest Alarm Info. Internal Air Temperature	20 to 125 [°C]	The internal air temperature during the occurrence of an alarm is recorded and displayed. For 20°C and below, 20°C is displayed. Display unit: °C
6_11	X30	Latest Alarm Info. Heat Sink Temperature	20 to 125 [°C]	The heat sink temperature during the occurrence of an alarm is recorded and displayed. For 20°C and below, 20°C is displayed. Display unit: °C

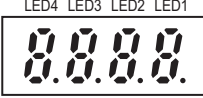
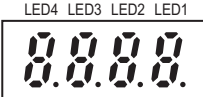
Item No.	Parameter No.	Item	Range	Description
6_12	X31, X32	Latest Alarm Info. Input Terminal, Latest Alarm Info. Output Terminal (Display depending on whether each segment of the LED is ON or OFF.)		The final command value of the terminal block I/O signal when an alarm occurs is displayed by lighting on the segment display. The display format is the same as the expression of I/O check. (Refer to 7-1-2 I/O check on page 7-11.)
6_13	X31	Latest Alarm Info. Input Terminal (Hexadecimal display)	0000Hex to FFFFHex	The final command value of the terminal block input signal when an alarm occurs is displayed by a four-digit hexadecimal. The display format is the same as the expression of I/O check. (Refer to 7-1-2 I/O check on page 7-11.)
6_14	X32	Latest Alarm Info. Output Terminal (Hexadecimal display)	0000Hex to FFFFHex	The final command value of the terminal block output signal when an alarm occurs is displayed by a four-digit hexadecimal. The display format is the same as the expression of I/O check. (Refer to 7-1-2 I/O check on page 7-11.)
6_15	X00	Latest Alarm History/ Number of Consecutive Same Alarms	0 to 255	Displays the number of times the same alarm occurred continuously. When the same alarm occurs continuously, the number of continuous occurrences is updated, and the oldest data is recorded to the last alarm and the newest data is recorded to the newest alarm.
6_16	X01	Latest Multiple Alarm1	Alarm code display	Simultaneously occurring alarm code (1st) when a main alarm occurred or while it is occurring ("----" is displayed if no alarm occurs simultaneously)
6_17	X02	Latest Multiple Alarm2	Alarm code display	Simultaneously occurring alarm code (2nd) when a main alarm occurred or while it is occurring ("----" is displayed if no alarm occurs simultaneously)
6_18	X33, X34	Latest Alarm Info. Input Terminal via Communication, Latest Alarm Info. Output Terminal via Communication (Display depending on whether each segment of the LED is ON or OFF.)		The final command value of the communication I/O signal when an alarm occurs is displayed by lighting on the segment display. The display format is the same as the expression of I/O check. (Refer to 7-1-2 I/O check on page 7-11.)
6_19	X33	Latest Alarm Info. Input Terminal via Communication (Hexadecimal display)	0000Hex to FFFFHex	The final command value of the communication input signal when an alarm occurs is displayed by a four-digit hexadecimal.



Item No.	Parameter No.	Item	Range	Description
6_20	X34	Latest Alarm Info. Output Terminal via Communication (Hexadecimal display)	0000Hex to FFFFHex	The final command value of the communication output signal when an alarm occurs is displayed by a four-digit hexadecimal.
6_21	X03	Latest Alarm Sub Code 1	0 to 9999	An auxiliary code for the alarm factors is displayed.
6_22	X36	Latest Alarm Info. Running Status 2	0000Hex to FFFFHex	<p>The running status 2 is displayed by a four-digit hexadecimal. 0000 to FFFF hex</p> <p>Bit 15: Motor type (1: PM motor / 0: Induction motor)</p> <p>Bit 14: During EN circuit diagnosis</p> <p>Bit 7: During speed control (1 during control)</p> <p>Bit5 to 4: Selected motor 00: 1st motor 01: 2nd motor 10: Reserved 11: Reserved</p> <p>Bit3 to 0: Control method 0000: V/f control without slip compensation 0001: Dynamic torque vector control 0010: V/f control with slip compensation 0011: V/f control with speed sensor 0100: Dynamic torque vector control with speed sensor 0101: Vector control without speed sensor 0110: Vector control with speed sensor 0111: Torque control (Vector control without speed sensor) 1000: Torque control (Vector control with speed sensor)</p>
6_23	X37	Latest Alarm Info. Speed Detection	B1E0(-fmax) to 4E20(fmax)	The speed detection value is displayed. The speed detection value with $\pm$ maximum frequency = $\pm 20000$ expressed in hexadecimal is displayed in increments of $\pm 0.01$ Hz.

Item No.	Parameter No.	Item	Range	Description
6_24	X38	Latest Alarm Info. Running Status 3	0000Hex to FFFFHex	The running status 3 is displayed by a four-digit hexadecimal. 0000 to FFFF hex Bit15: --- Bit14: OL (Overload warning) Bit13: LOC (Light load detection) Bit12: OL2 (Overload warning 2) Bit11: OLP (During active drive) Bit10: LIFE (Life warning) Bit9: OHF (Fin Overheat warning) Bit8: TRY (During retry) Bit7: FAN (Fan operation signal) Bit6: REF (RUN command source) Bit5: THM (Thermal warning) Bit4: IPF (During restart after instantaneous power failure) Bit3: SETM (2nd motor selection) Bit2: IRDY (Operation ready) Bit1: FDT1 (Over set frequency arrival signal 1) Bit0: FAR1 (Constant speed arrival)
6_25	X04	Latest Multiple Alarm Sub Code 2	0 to 9999	The sub code when multiple alarms occurred is displayed.
6_30	X108	Latest Alarm Info. Cumulative Running Time	0 to 655,350 hours	The cumulative time of the inverter RUN state is displayed. The cumulative operation time is displayed alternately in the upper digits and lower digits. When the lower three digits are displayed, an h (hours) is displayed in the lowermost digit.
6_31	X49	Fault Counter	0 to 9999 1000 to 6553 [x10 LED]	The number of times the inverter trips is displayed. The number of times is saved in the EEPROM when the power is turned OFF. Counting is performed from 0 to 65535, and if 65535 times is exceeded, the display remains as 65535. By setting "7: Clear alarm history" to Data Initialization (H03), the value is cleared to 0.
<b>2 The last alarm</b>				
6_00	X60	Last Info. Alarm Info. Output Frequency	0.00 to 99.99, 100.0 to 590.0 [Hz]	The output frequency before slip compensation is displayed in increments of 0.01 Hz. A value of 100.0 Hz or higher is displayed in increments of 0.1 Hz.
6_01	X61	Last Alarm Info. Output Current	0.00 to 99.99, 100.0 to 655.3 [A]	The output current is displayed. A current value of 100.0A or higher is displayed in increments of 0.1 A. Display unit: A (Ampere)
6_06	X65	Last Alarm Info. Running Status	0000Hex to FFFFHex	The operation status is displayed by a four-digit hexadecimal.

Item No.	Parameter No.	Item	Range	Description
6_07	X66	Last Alarm Info. Cumulative Ope. Time	0 to 655,350 hours	The number of operations of the motor (number of times the RUN command for the inverter is turned ON) is calculated and displayed.
6_09	X68	Last Alarm Info. Main Circuit DC Voltage	0.0 to 999.0 [V]	The Main Circuit DC Voltage of the inverter is displayed.
6_30	X118	Last Alarm Info. Cumulative Running Time	0 to 655,350 hours	The cumulative time of the inverter RUN state is displayed. The cumulative operation time is displayed alternately in the upper digits and lower digits. When the lower three digits are displayed, an h (hours) is displayed in the lowermost digit.
<b>3 Second last alarm</b>				
6_00	Z00	Second Last Alarm Info. Output Frequency	0.00 to 99.99, 100.0 to 590.0 [Hz]	The output frequency before slip compensation is displayed in increments of 0.01 Hz. A value of 100.0 Hz or higher is displayed in increments of 0.1 Hz.
6_01	Z01	Second Last Alarm Info. Output Current	0.00 to 99.99, 100.0 to 655.3 [A]	The output current is displayed. A current value of 100.0A or higher is displayed in increments of 0.1 A. Display unit: A (Ampere)
6_06	Z05	Second Last Alarm Info. Running Status	0000Hex to FFFFHex	The operation status is displayed by a four-digit hexadecimal.
6_07	Z06	Second Last Alarm Info. Cumulative Ope. Time	0 to 655,350 hours	The number of operations of the motor (number of times the RUN command for the inverter is turned ON) is calculated and displayed.
6_09	Z08	Second Last Alarm Info. Main Circuit DC Voltage	0.0 to 999.0 [V]	The Main Circuit DC Voltage of the inverter is displayed.
6_30	X128	Second last Alarm Info. Cumulative Running Time	0 to 655,350 hours	The cumulative time of the inverter RUN state is displayed. The cumulative operation time is displayed alternately in the upper digits and lower digits. When the lower three digits are displayed, an h (hours) is displayed in the lowermost digit.
<b>4 Third last alarm</b>				
6_00	Z50	Third Last Alarm Info. Output Frequency	0.00 to 99.99, 100.0 to 590.0 [Hz]	The output frequency before slip compensation is displayed in increments of 0.01 Hz. A value of 100.0 Hz or higher is displayed in increments of 0.1 Hz.
6_01	Z51	Third Last Alarm Info. Output Current	0.00 to 99.99, 100.0 to 655.3 [A]	The output current is displayed. A current value of 100.0A or higher is displayed in increments of 0.1 A. Display unit: A (Ampere)
6_06	Z55	Third Last Alarm Info. Running Status	0000Hex to FFFFHex	The operation status is displayed by a four-digit hexadecimal.

Item No.	Parameter No.	Item	Range	Description
6_07	Z56	Third Last Alarm Info. Cumulative Ope. Time	0 to 655,350 hours	The number of operations of the motor (number of times the RUN command for the inverter is turned ON) is calculated and displayed.
6_09	Z58	Third Last Alarm Info. Main Circuit DC Voltage	0.0 to 999.0 [V]	The Main Circuit DC Voltage of the inverter is displayed.
6_30	X138	Third last Alarm Info. Cumulative Running Time	0 to 655,350 hours	The cumulative time of the inverter RUN state is displayed. The cumulative operation time is displayed alternately in the upper digits and lower digits. When the lower three digits are displayed, an h (hours) is displayed in the lowermost digit.
<b>5 Fourth last alarm</b>				
6_00	X141	Fourth last Alarm Info. Output Frequency	0.00 to 99.99, 100.0 to 590.0 [Hz]	The output frequency before slip compensation is displayed in increments of 0.01 Hz. A value of 100.0 Hz or higher is displayed in increments of 0.1 Hz.
6_01	X142	Fourth last Alarm Info. Output Current	0.00 to 99.99, 100.0 to 655.3 [A]	The output current is displayed. A current value of 100.0A or higher is displayed in increments of 0.1 A. Display unit: A (Ampere)
6_06	X149	Fourth Last Alarm Info. Running Status	0000Hex to FFFFHex	The operation status is displayed by a four-digit hexadecimal.
6_07	X143	Fourth Last Alarm Info. Cumulative Ope. time	0 to 655,350 hours	The number of operations of the motor (number of times the RUN command for the inverter is turned ON) is calculated and displayed.
6_09	X144	Fourth Last Alarm Info. Main Circuit DC Voltage	0.0 to 999.0 [V]	The Main Circuit DC Voltage of the inverter is displayed.
6_30	X148	Fourth Last Alarm Info. Cumulative Running Time	0 to 655,350 hours	The cumulative time of the inverter RUN state is displayed. The cumulative operation time is displayed alternately in the upper digits and lower digits. When the lower three digits are displayed, an h (hours) is displayed in the lowermost digit.
<b>6 Fifth last alarm</b>				
6_00	X151	Fifth Last Alarm Info. Output Frequency	0.00 to 99.99, 100.0 to 590.0 [Hz]	The output frequency before slip compensation is displayed in increments of 0.01 Hz. A value of 100.0 Hz or higher is displayed in increments of 0.1 Hz.
6_01	X152	Fifth Last Alarm Info. Output Current	0.00 to 99.99, 100.0 to 655.3 [A]	The output current is displayed. A current value of 100.0A or higher is displayed in increments of 0.1 A. Display unit: A (Ampere)

Item No.	Parameter No.	Item	Range	Description
6_06	X159	Fifth Last Alarm Info. Running Status	0000Hex to FFFFHex	The operation status is displayed by a four-digit hexadecimal.
6_07	X153	Fifth Last Alarm Info. Cumulative Ope. Time	0 to 655,350 hours	The number of operations of the motor (number of times the RUN command for the inverter is turned ON) is calculated and displayed.
6_09	X154	Fifth last Alarm Info. Main Circuit DC Voltage	0.0 to 999.0 [V]	The Main Circuit DC Voltage of the inverter is displayed.
6_30	X158	Fifth last Alarm Info. Cumulative Running time	0 to 655,350 hours	The cumulative time of the inverter RUN state is displayed. The cumulative operation time is displayed alternately in the upper digits and lower digits. When the lower three digits are displayed, an h (hours) is displayed in the lowermost digit.

## Running Status 3 Monitor [6\_24]

The operation status 3 displays the status allocated to each bit by a four-digit hexadecimal. The allocation for 0 to 15 bits of the operation status is described in the table below.

Bit	Symbol	Description
15	-	Fixed to 0
14	ID2	Current detection 2
13	IDL	Low current detection
12	ID	Current detection
11	OLP	During active drive
10	LIFE	Life warning
9	OH	Heat sink overheat early warning
8	TRY	During retry
7	FAN	Fan operation signal
6	KP	During touch panel operation
5	OL	Motor overload early warning
4	IPF	During restart after instantaneous power failure
3	SWM2	Motor 2 selection
2	RDY	During operation preparation
1	FDT	Frequency detection
0	FAR	Frequency arrival

## 7-2 Multifunction Input/Output Functions List

This section describes the input/output signals of the inverter.

### 7-2-1 Multifunction Input Selection

By allocating the following functions to the Input Terminal [DI1] Function Selection to Input Terminal [DI7] Function Selection (E01 to E05, E98, E99), the set function can be operated. However, “98: FW (Forward Run/Stop)” and “99: RV (Reverse Run/Stop)” can be allocated to only Input Terminal [DI6] Function Selection (E98) or Input Terminal [DI7] Function Selection (E99).

By setting data in which 1000 is added to the set data of the following functions that are to be used, it is possible to switch the input terminals [DI1] to [DI7] from an NO contact input to an NC contact input. However, as a standard, “6: STP (3-wire stop),” “9: EXT (External trip),” “23: ATR (Torque command input permission)” and “30: STOP (Force to stop (30 = Active OFF; 1030 = Active ON))” are set to an NC contact, and change to an NO contact by setting data in which 1000 is added.

If the same function is allocated to the multifunction input terminals, and if any one of the multifunction input terminals to which the function is allocated, except for the exceptions below, turns ON, the function is handled as ON.

Exception: If all terminals to which “9: EXT (External trip),” “30: STOP (Force to stop),” “38: ROK (Permission of Run command),” “98: FW (Forward Run/Stop)” or “99: RV (Reverse Run/Stop)” is allocated are ON, the function is handled as ON.

Input terminals or output terminals can be forcibly manipulated via communication by setting Support Tool Link Function Selection (y99). (Refer to *8-10 Command via Communications* on page 8-87.)

When operation via communication is set to enabled (y99 = 2, 3), the function allocated to the input terminal can be operated via communication. Handling of commands via communication and commands via terminal blocks differs according to each individual function that is allocated.

For how to handle commands when operation via communication is enabled (y99 = 2, 3), refer to the symbols in the “Communication function” column in the table below. The following shows the meanings of the symbols.

- E: Signals wired to the input terminal are disabled and operation follows commands instructed by Operation command (S06).
- O: O: Handled as ON when whichever of signals wired to the input terminal or commands instructed by Operation command (S06) are ON.
- A: A: Handled as ON when both signals wired to the input terminal and commands instructed by Operation command (S06) are ON.
- : Changes cannot be made by the communications function

Parameter No.	Data	Description	Com-mu-nica-tions function	Reference item	Page
E01 to E05, E98, E99	0	CF1: Multi-step frequency setting binary 1	E	Multi-step speed operation function	page 5-57
	1	CF2: Multi-step frequency setting binary 2	E		
	2	CF3: Multi-step frequency setting binary 3	E		
	3	CF4: Multi-step frequency setting binary 4	E		
	4	RT1: Select ACC/DEC time (2 steps)	E	2-step acceleration/deceleration function	page 5-43
	5	RT2: Select ACC/DEC time (4 steps)	E	2-step acceleration/deceleration	page 5-66
	6	STP: 3-wire stop: NC contact	-	3-wire input function	page 5-56
	7	FRS: Free-run stop	O	Free-run stop	page 7-60
	8	RS: Reset	O	Reset Reset (RS)	page 5-49 page 5-66
	9	EXT: External trip: NC contact	-	External trip	page 7-87
	10	JG: Jogging	O	Jogging	page 5-60
	12	SET: Set 2nd control	O	2nd control function	page 5-52
	13	DB: External DC injection braking	E	Direct current braking	page 7-63
	14	TRQ1: Torque limit switching 1	E	Torque limit function	page 6-81
	15	CS: Commercial switch	E	Commercial switching	page 7-141
	16	SW60: Commercial switch (60Hz)	E		
	17	UP: UP/DWN function accelerated	-	Remote operation function	page 7-119
	18	DWN: UP/DWN function decelerated	-		
	19	SFT: Soft lock	O	Soft lock	page 7-74
	20	PID: PID enabled/disabled	E	PID function	page 7-123
	21	IVS: Switch normal/inverse operation	E		
	22	IL: Interlock	-	Restart after Momentary Power Failure	page 7-155

Parameter No.	Data	Description	Com- mu- ni- ca- tions func- tion	Reference item	Page
E01 to E05, E98, E99	23	ATR: Torque command input permission: NC contact	E	Torque control	page 6-31
	25	U-DI: Universal DI	-	Universal Terminal	page 7-49
	26	STM: Enable auto search for idling motor speed at starting	O	Restart after Momentary Power Failure	page 7-51
	30	STOP: Force to stop: NC contact	A	Forced Stop	page 7-152
	32	EXITE: Pre-excite	E	Pre-excitation	page 7-151
	33	PIDC: PID integral reset	E	PID function	page 7-123
	34	PID-HLD: Hold PID integral component	E		
	35	OPE: Forced operator	-	Forced operation function	page 7-75
	38	ROK: Permission of Run command	E	Permission of RUN Command	page 7-117
	42	ORL: Zero return limit signal	O	Position control	page 6-36
	44	Do not set.	O	-	-
	46	OLS: Enable overload stop	E	Overload Stop Function	page 7-153
	47	LOCK: Servo lock	E	Servo lock	page 7-148
	58	UDC: UP/DWN function data clear	O	Remote operation function	page 7-119
	59	BATRY: Enable battery-driven operation	E	Battery Operation Enable Command (BATRY)	page 7-155
	60	TB1: Select torque bias 1	E	Torque bias function	page 6-33
	61	TB2: Select torque bias 2	E		
	62	H-TB: Hold torque bias	E		
	65	BOK: Brake confirmation	-	Brake control function	page 6-72
	70	Hz/LSC: Cancel line speed control	E	Line speed control cancellation	page 6-79
71	LSC-HLD: Hold line speed control frequency in the memory	E	Line speed control frequency memory	page 6-79	
72	CRUN-M1: Count the run time of commercial power-driven motor 1	O	Commercial switching	page 7-141	
73	CRUN-M2: Count the run time of commercial power-driven motor 2	O			
76	DROOP: Select droop control	E	Droop Control	page 7-149	



Parameter No.	Data	Description	Com-mu-nica-tions function	Reference item	Page
E01 to E05, E98, E99	78	MPRM1: Select speed control parameter 1	E	Speed Control Settings	page 6-26
	79	MPRM2: Select speed control parameter 2	E		
	80	Do not set.	E	-	-
	81	Do not set.	E	-	-
	82	AR-CCL: Cancel anti-regenerative control	E	Overvoltage Suppression Function during Deceleration	page 7-85
	84	LAC: Acceleration and deceleration time cancel	E	Acceleration/deceleration time setting	page 5-39
	85	AHD: Analog command held	O	Retention of analog command function	page 7-45
	94	FJOG: Run forward with Jogging	E	Jogging (JG)	page 5-60
	95	RJOG: Run reverse with Jogging	E		
	97	F/R: 3-wire forward/reverse	O	3-wire input function	page 5-56
	98	FW: Forward Run/Stop*1	E	RUN command selection Forward RUN command (FW) and reverse RUN command (RV) P	page 5-25 page 5-55
	99	RV: Reverse Run/Stop*1	E		
	100	no: No function assigned	E	-	-
	119	P-SEL: Proportional operation of speed regulator	O	Position control	page 6-36
	121	Do not set.	O	-	-
	122	Do not set.	O	-	-
	123	Do not set.	O	-	-
	124	Do not set.	O	-	-
	125	Do not set.	O	-	-
	126	Do not set.	O	-	-
	127	Do not set.	O	-	-
	134	Do not set.	O	-	-
	135	ABS/INC: Relative / absolute position command	E	Positioning data	page 6-41
136	ORT: Orientation command	E	Orientation	page 6-49	

Parameter No.	Data	Description	Com- mu- nica- tions func- tion	Reference item	Page
E01 to E05, E98, E99	137	SPD: Speed control/position control switching	E	Position control	page 6-36
	138	ORG: Zero return startup signal	E		
	139	FOT: Forward driving stop	-	Position control	page 6-43
	140	ROT: Reverse driving stop	-		
	141	PCLR: Position clear command	O	Clearing of position	page 6-48
	142	PSET: Position preset command	O	Position preset	page 6-49
	144	POS-SET: Target position update command	E	Positioning data	page 6-41
	145	CP1: Position command selection 1	E		
	146	CP2: Position command selection 2	E		
	147	CP3: Position command selection 3	E		
	159	2CH: 2-step acceleration/deceleration	E	2-step acceleration/deceleration function 2-step acceleration/deceleration	page 5-43 page 5-66
	160	485: Starting communication signal	E	EzCOM	page 8-27
	161	ADD: Frequency addition	E	Frequency addition function	page 7-118
	162	F-TM: Forced terminal block	-	Forced terminal block function	page 7-75
	163	HLD: Retain output frequency	E	Acceleration/deceleration stop function	page 5-42
	164	KHC: Integrated power clear	O	Integrated power clear (KHC)	page 7-112
	171	PID-SS1: PID control multistage command 1	E	PID function	page 7-123
	172	PID-SS2: PID control multistage command 2	E		
	173	SF1: Multi-step frequency setting bit 1	E	Multi-step speed operation function	page 5-57
	174	SF2: Multi-step frequency setting bit 2	E		
175	SF3: Multi-step frequency setting bit 3	E			
176	SF4: Multi-step frequency setting bit 4	E			
177	SF5: Multi-step frequency setting bit 5	E			

Parameter No.	Data	Description	Com-mu-nica-tions function	Reference item	Page
E01 to E05, E98, E99	178	SF6: Multi-step frequency setting bit 6	E	Multi-step speed operation function	page 5-57
	179	SF7: Multi-step frequency setting bit 7	E		
	184	TL: Torque limit enabled	E	Torque limit function	page 6-81
	185	TRQ2: Torque limit switching 2	E		
	186	USP: Unattended start protection	-	Power recovery restart prevention function	page 7-59
	187	EXT1: External Latch Input 1*2	-	Touch Probe (Latch) Function	page 6-62
	188	EXT2: External Latch Input 2*2	-		

\*1. Forward rotation and reverse rotation can be allocated only to the DI6 and DI7 terminals.

\*2. External latch input 1 and external latch input 2 can be allocated only to DI1 and DI2.

## 7-2-2 Multifunction Output Selection

The following functions can be allocated to Output Terminal [DO1] Function Selection (E20), Output Terminal [DO2] Function Selection (E21) or Output Terminal [ROA, ROB] Function Selection (E27). The multifunction output terminals DO1 and DO2 are open collector outputs, and the multifunction relay output terminals ROA/B/C are relay outputs.

By setting data in which 1000 is added to the set data of the following functions that are to be used, it is possible to switch the multifunction output terminals DO1, DO2 and ROA/B/C from an NO contact input to an NC contact input.

Parameter No.	Data	Description	Reference item	Page
E20, E21, E27	0	RUN: Run Signal	Signal during run	page 5-68
	1	FAR1: Frequency arrival signal 1 (constant speed)	Constant speed arrival signal	page 5-70
	2	FAR2: Over set frequency arrival signal 1	Frequency arrival signal	page 7-89
	3	UV: Signal during undervoltage	Restart after Momentary Power Failure	page 7-52
	4	B/D: Detected torque polarity	Torque control	page 6-31
	5	IOL: Inverter output limiting	Inverter output limiting	page 7-106
	6	IPF: Auto-restarting after momentary power failure	Restart after Momentary Power Failure	page 7-52
	7	THM: Thermal warning	Electronic thermal warning	page 5-23
	8	REF: Run Command Source	RUN command status signal	page 7-105
	10	IRDY: Operation ready signal	Operation ready completion signal	page 5-68

Parameter No.	Data	Description	Reference item	Page
E20, E21, E27	15	AX: Switch MC on the input power lines (for inverter input-side electromagnetic contactor)	Switch MC on the input power lines	page 7-107
	16	TU: Pattern operation stage transition	Pattern operation	page 5-33
	17	TO: Pattern operation cycle completed	Pattern operation	
	18	STG1: Pattern operation stage 1	Pattern operation	
	19	STG2: Pattern operation stage 2	Pattern operation	
	20	STG4: Pattern operation stage 4	Pattern operation	
	21	FAR2: Frequency arrival signal 2	Frequency arrival signal	page 7-89
	22	IOL2: Inverter output limiting with delay	Inverter output limiting	page 7-106
	25	FAN: Cooling fan in operation	Cooling FAN control method selection	page 7-99
	26	TRY: Auto-resetting	Trip Retry Operation	page 7-58
	27	Reserved	-	page 7-155
	28	OHF: Fin overheat warning	Cooling fin overheat warning	page 7-102
	29	SY: Synchronization completed	Simultaneous Start Synchronized Run Operation	-
	30	LIFE: Lifetime alarm	Lifetime alarm (LIFE)	page 7-100
	31	FDT2: Over set frequency arrival signal 2	Frequency arrival signal	page 7-89
	33	REFOFF: Reference loss detected	Frequency Reference	page 5-29
	35	RUN2: Inverter outputting	Signal during run	page 5-68
	36	OLP: Overload prevention controlling	Overload Limit/Overload Warning	page 7-82
	37	OL2: Overload warning 2		
	38	OL: Overload warning		
41	LOC: Light load detection signal	Low current signal	page 7-102	
42	OD: Excessive PID deviation	PID Function	page 7-123	
43	PID-CTL: Under PID control	PID Function		
44	PID-STP: Under sleep mode of PID control	PID Function		
46	OTQ: Overtorque	Overtorque/undertorque	page 6-85	

Parameter No.	Data	Description	Reference item	Page
E20, E21, E27	48	SWM1: 1st motor in operation	1st control under selection signal	page 7-105
	49	SETM: 2nd motor in operation	2nd control under selection signal	
	52	FWR: Forward run signal	Forward run signal	page 5-69
	53	RVR: Reverse run signal	Reverse run signal	page 5-69
	54	RMT: Under remote mode	Forced operator	page 7-75
	56	MOH: Motor overheat detected by thermistor	Thermistor Trip Function	page 7-88
	57	BRK: Brake release	Brake control function	page 6-72
	59	AIIDc: Analog AI2 (All) disconnection detection	Window comparator	page 7-103
	70	ZS: 0 Hz signal	0 Hz detection function	page 5-71
	71	DSAG: Speed agreement	Motor control method with speed sensor	page 6-12
	72	FAR3: Frequency arrival signal 3	Frequency arrival signal	page 7-89
	76	DSE: Excessive speed deviation	Motor control method with speed sensor	page 6-12
	77	U-EDC: Low DC link bus voltage detection	Low DC link bus voltage detection	page 7-106
	79	IPF2: During decelerating at momentary power failure	Restart after Momentary Power Failure	page 7-56
	82	POK: Position ready	Position control	page 6-36
	84	MNT: Maintenance timer counted up	Maintenance monitor	page 7-93
	87	FAR1FDT1: Frequency match detection	Frequency arrival signal	page 7-89
	89	PTD: Pole tuning done	Synchronous motor (PM)	page 6-20
	90	Do not set.	-	-
	91	Do not set.	-	-
	92	Do not set.	-	-
	93	Do not set.	-	-
	95	Do not set.	-	-
98	L-ALM: Minor alarm	Minor alarm list	page 7-108	
99	AL: Alarm output	Alarm list	page 5-71	
101	DECF: EN circuit failure detected	Safety function (Set by the EDM selector switch)	page 7-70	
102	EDM: STO (Safe Torque Off) Performance Monitor			

Parameter No.	Data	Description	Reference item	Page
E20, E21, E27	105	DBAL: Braking transistor broken	Braking transistor broken (DBAL)	page 7-98
	111	Do not set.	-	-
	112	Do not set.	-	-
	113	Do not set.	-	-
	114	Do not set.	-	-
	115	Do not set.	-	-
	116	Do not set.	-	-
	117	Do not set.	-	-
	118	Do not set.	-	-
	119	Do not set.	-	-
	120	Do not set.	-	-
	132	TRQ: Torque limit	Torque limit function	page 6-81
	151	OT-OUT: Overtravel detection	Over-travel	page 6-43
	152	STOP-OUT: Forced stop detection	Forced Stop	page 7-152
	182	BER: Brake error	Brake control function	page 6-72
	183	FDT3: Set-frequency-only arrival signal	Frequency arrival signal	page 7-89
	185	FDT4: Set-frequency-only arrival signal 2		
	186	FBV: PID FB status output	PID function	page 7-123
	187	FR: Starting contact signal	Starting contact signal	page 7-101
	188	FREF: Frequency Command Source	Frequency reference selection status signal	page 7-105
	206	LOG1: Logic operation output 1	Logical operation function	page 7-94
	207	LOG2: Logic operation output 2		
	208	LOG3: Logic operation output 3		
	209	NDc: Network error	Communications disconnection detection signal	page 7-101
	236	ONT: Power ON time over	RUN time/Power ON time over	page 7-92
	237	RNT: RUN time over		
238	AI1Dc: Analog AI1 disconnection detection	Window comparator	page 7-103	
239	AIVDc: Analog AI2 (AIV) disconnection detection			
240	WAC: Capacitor life warning signal	Capacitor life warning signal	page 7-96	
241	WAF: Cooling fan life warning signal	Cooling fan life warning signal	page 7-99	

## 7-3 Analog I/O Settings

This section describes the analog I/O signal settings for this inverter.

### 7-3-1 Analog Input Function Selection

This inverter has two types of analog input terminals, a current input and a voltage input. The analog input terminal [AI1] has a voltage input only. Analog input terminal [AI2] can be switched between current input (factory default setting) and voltage input and used by Analog input selector switch (SW3).

Analog input terminal [AI1]	0 to 10 V, -10 to 10 V
Analog input terminal [AI2] (All)	4 to 20 mA, 0 to 20 mA
Analog input terminal [AI2] (AIV)	0 to 10V

- For details on analog input adjustment, refer to 7-3-2 *Analog Input Adjustment Function* on page 7-38.
- One function is allocated to an analog input terminal. One input cannot be used simultaneously for another function.
- If the same function is selected at the analog input terminal [AI1] function selection and analog input terminal [AI2] function selection, the signal from the input terminal [AI1] is given priority.

Parameter No.	Function name	Data	Default data	Unit
E61/E62/E63	Input Terminal [AI1] Function Selection/ Input Terminal [AI2] Function Selection (All)/ Input Terminal [AI2] Function Selection (AIV)	0: Extension function not allocated 1: Auxiliary frequency setting 1 2: Auxiliary frequency setting 2 3: PID command *1 5: PID feedback 6: Ratio setting 7: Analog torque limiter 9: Torque bias*1 10: Torque command*1 11: Torque current command*1 17: Speed limit for forward rotation 18: Speed limit for reverse rotation 20: Analog signal input monitor 21: PID feed forward	0	-
C35	Input Terminal [AI1] Polarity Selection	0: Bipolar (-10 to 10 V) 1: Unipolar (0 to 10 V)	1	-
C40	Input Terminal [AI2] Operation Selection (All)*2	0: 4 to 20mA Unipolar (limited to less than 0) 1: 0 to 20mA Unipolar 10: 4 to 20mA Bipolar (negative number display) 11: 0 to 20mA Bipolar	0	-
C45	Input Terminal [AI2] Polarity Selection (AIV)	0: Bipolar (0 to 10 V) 1: Unipolar (0 to 10 V)	1	-

\*1. When using PID process command 1, torque bias, torque reference value and torque current command value with analog input terminals, configure parameters for selecting commands of each function in addition to

Input Terminal [AI1] Function Selection (E61), Input Terminal [AI2] Function Selection (All) (E62) and Input Terminal [AI2] Function Selection (AIV) (E63). When both are set to analog input, analog input signal is treated as a command.

- \*2. Depending on unipolar or bipolar, a bias value below 0 switches between enabled and disabled for Terminal [AI2] (All function) (Range / polarity selection).

For details, refer to 7-3-2 *Analog Input Adjustment Function* on page 7-38.

## Analog Input Extended Function Selection (E61, E62, E63)

By setting Input Terminal [AI1] Function Selection (E61), Input Terminal [AI2] Function Selection (All) (E62) and Input Terminal [AI2] Function Selection (AIV) (E63), the following functions can be allocated to each of the analog input terminals.

E61, E62, E63 data	Function	Description
0	None	-
1	Auxiliary frequency setting 1	An auxiliary frequency input added to 1st Frequency Reference Selection (F01). Not added to other than the 1st frequency reference (such as the 2nd frequency reference, multi-step frequency reference, etc.). 100%/Full scale
2	Auxiliary frequency setting 2	An auxiliary frequency input added to all frequency settings. Added to frequency setting 1, frequency setting 2, multistep frequency, etc. 100%/Full scale
3	PID command	Enter the command source for the temperature, pressure, etc. in PID control. It is also necessary to set PID Control PID Command Selection (J02).
5	PID feedback	Enter the feedback for the temperature, pressure, etc. in PID control. Set "0: Analog input" at PID Control Feedback Selection (E119). 100%/Full scale
6	Ratio setting	The ratio setting is used for the constant line speed control by diameter calculation of the winding machine and the ratio operation of multiple units, and is therefore calculated as percentage in the last frequency reference. 100%/Full scale
7	Analog torque limiter	Used when the analog input is used as torque limit instead of Torque Limit 1 (F40). 200%/Full scale
9	Torque bias	The analog input is used as the torque bias value. Set "2: Analog input" at Torque Bias Function Selection (H154). 200%/Full scale
10	Torque command	During torque control, the analog input is used as the torque command. Set "2: Torque current command input" or "3: Torque command input" at Torque Control Operate Selection (H18) and "0: Analog input" at Torque Reference Selection (H332).
11	Torque current command	During torque control, the analog input is used as the torque current command. Set "2: Torque current command input" or "3: Torque command input" at Torque Control Operate Selection (H18) and "0: Analog input" at Torque Reference Selection (H332).



E61, E62, E63 data	Function	Description
17	Speed limit for forward rotation	The analog input is used as the output frequency limit value. Analog input 100% is equivalent to Maximum Output Frequency (F03/A01).
18	Speed limit for reverse rotation	When using this function, the concomitant use of Over Speed Detection Level (d35) is recommended.
20	Analog Input Monitor	By connecting analog signals to the inverter, the display coefficient can be used to convert and display analog signals as temperature, pressure and other physical quantities via communications. 100%/Full scale
21	PID feed forward	Enter the feedforward such as the temperature, pressure, etc. in PID control. Set "1: Input terminal (AI1, AI2)" to PID Control PID Feedforward Selection for Process Control (E121). 100%/Full scale

## Using an Analog Input in Command System Parameters

- When using analog input terminals by the following functions, configure parameters for selecting the commands of each function in addition to Input Terminal [AI1] Function Selection (E61), Input Terminal [AI2] Function Selection (AI1) (E62) and Input Terminal [AI2] Function Selection (AIV) (E63). When both are set to analog input, analog input signal is treated as a command.

Function	Command setting	E61, E62, E63 data	Reference
Frequency command	1st Frequency Reference Selection (F01)/2nd Frequency Reference Selection (C30) = 1: Analog Voltage Input (Input Terminal [AI1]) 2: Analog Current Input (Input Terminal [AI2] (AI1)) 3: Analog Voltage Input (Input Terminal [AI1]) + Analog Current Input (Input Terminal [AI2] (AI1)) 5: Analog Voltage Input (Input Terminal [AI2] (AIV))	0: Frequency command	page 5-27
Torque command	Torque Control Operate Selection (H18) = "3: Valid (Torque command: Torque Reference)" Torque Reference Selection (H332) = "0: Input from analog (AI1, AI2) terminal"	10: Torque reference value	page 6-31
Torque current command	Torque Control Operate Selection (H18) = "2: Valid (Torque control: Torque Current Command)" Torque Reference Selection (H332) = "0: Input from analog (AI1, AI2) terminal"	11: Torque current command value	page 6-31
Torque bias	Torque Bias Function Selection (H154) = "2: Analog torque bias"	9: Torque bias	page 6-33

Function	Command setting	E61, E62, E63 data	Reference
PID command	PID Control PID Command Selection (J02) = "1: Analog input (terminals AI1, AI2 (All), AI2 (AIV))"	3: PID command	page 7-123
PID feedback	PID Control Feedback Selection (E119) = "0: Analog input terminals (AI1, AI2 (All function), AI2 (AIV function))"	5: PID feedback	page 7-123

### 7-3-2 Analog Input Adjustment Function

This function adjusts the offset, bias and gain of the analog input terminals [AI1] and [AI2].

- The analog input terminal AI has a voltage input only. AI2 can be switched between current and voltage by Analog input selector switch (SW5).
- Select the polarity (C35, C40, C45) of the analog signal to input and set the input range of the analog signal.
- Add the values set at offsets (C31, C36, C41) to the analog input values of each terminal, and adjust for shift of the offsets.
- Set the bias (command) (C55, C61, C67) and gain (command) (C34, C37, C42), and convert the analog signal to digital value and adjust the resulting signal. Adjust the base point of bias (command) and gain (command) at bias (analog input) (C56, C62, C68) and gain (analog input) (C35, C38, C43).
- Filters (C33, C38, C43) can be set to remove noise.

Parameter No.	Function name	Data	Default data	Unit
<b>Input terminal [AI1] settings</b>				
C35	Input Terminal [AI1] Polarity Selection	0: Bipolar (-10 to 10 V) 1: Unipolar (0 to 10 V)*1	1	-
C31	Input Terminal [AI1] Offset	-5.0 to 5.0 %	0.0	%
C33	Input Terminal [AI1] Filter	0.00 to 5.00 s	0.05	s
C32	Input Terminal [AI1] Gain (Command)	0.00 to 400.00 %	100.00	%
C34	Input Terminal [AI1] Gain (Analog Input)	0.00 to 100.00 %	100.00	%
<b>Bias adjustment on 1st frequency reference</b>				
F18	Input Terminal [AI1, AI2] Bias for 1st Frequency Command	-100.00 to 100.00 %	0.00	%
C50	Input Terminal [AI1, AI2] Bias Analog Input for 1st Frequency Command	0.00 to 100.00 %	0.00	%
<b>Bias adjustment on 2nd frequency reference</b>				
C55	Input Terminal [AI1] Bias (Command)	-200.00 to 200.00 %	0.00	%
C56	Input Terminal [AI1] Bias (Analog Input)	0.00 to 100.00 %	0.00	%
<b>Input terminal [AI2] (All) settings</b>				

Parameter No.	Function name	Data	Default data	Unit
C40	Input Terminal [AI2] Operation Selection (All)	0: 4 to 20mA Unipolar (limited to less than 0) 1: 0 to 20mA Unipolar 10: 4 to 20mA Bipolar (negative number display) 11: 0 to 20mA Bipolar	11	-
C36	Input Terminal [AI2] Offset (All)	-5.0 to 5.0 %	0.0	%
C38	Input Terminal [AI2] Filter (All)	0.00 to 5.00 s	0.05	s
C37	Input Terminal [AI2] Gain (All Command)	0.00 to 400.00 %	100.00	%
C39	Input Terminal [AI2] Gain (All Analog Input)	0.00 to 100.00 %	100.00	%
Bias adjustment on 1st frequency reference				
F18	Input Terminal [AI1, AI2] Bias for 1st Frequency Command	-100.00 to 100.00 %	0.00	%
C50	Input Terminal [AI1, AI2] Bias Analog Input for 1st Frequency Command	0.00 to 100.00 %	0.00	%
Bias adjustment on 2nd frequency reference				
C61	Input Terminal [AI2] Bias (All Command)	-200.00 to 200.00 %	0.00	%
C62	Input Terminal [AI2] Bias (All Analog Input)	0.00 to 100.00 %	0.00	%
<b>Input terminal [AI2] (AIV) settings</b>				
C45	Input Terminal [AI2] Polarity Selection (AIV)	0: Bipolar (0 to 10 V) 1: Unipolar (0 to 10 V)	1	-
C41	Input Terminal [AI2] Offset (AIV)	-5.0 to 5.0 %	0.0	%
C43	Input Terminal [AI2] Filter (AIV)	0.00 to 5.00 s	100.00	%
C42	Input Terminal [AI2] Gain (AIV Command)	0.00 to 400.00 %	0.05	s
C44	Input Terminal [AI2] Gain (AIV Analog Input)	0.00 to 100.00 %	100.00	%
Bias adjustment on 1st frequency reference				
F18	Input Terminal [AI1, AI2] Bias for 1st Frequency Command	-100.00 to 100.00 %	0.00	%
C50	Input Terminal [AI1, AI2] Bias Analog Input for 1st Frequency Command	0.00 to 100.00 %	0.00	%
Bias adjustment on 2nd frequency reference				
C67	Input Terminal [AI2] Bias (AIV Command)	-200.00 to 200.00 %	0.00	%
C68	Input Terminal [AI2] Bias (AIV Analog Input)	0.00 to 100.00 %	0.00	%

\*1. If unipolar is selected for Terminal [AI1] (Polarity selection), the negative voltage is considered to be 0 V.

## Polarity Selection (C35, C40, C45)

Set the input range of analog input voltage/current.

Input Terminal [AI1] Polarity Selection (C35) data	Function	Description
0	Bipolar (-10 to 10 V)	When analog signals are changed to digital values after application of bias, values less than 0% are enabled as minus values.
1	Unipolar (0 to 10 V)	When analog signals are changed to digital values after application of bias, values less than 0% are limited at 0%.

Input Terminal [AI2] Operation Selection (All) (C40) data	Function	Description
0	4 to 20mA Unipolar (limited to less than 0)	When analog signals are changed to digital values after application of bias, values less than 0% are limited at 0%.
1	0 to 20mA Unipolar	
10	4 to 20mA Bipolar (negative number display)	When analog signals are changed to digital values after application of bias, values less than 0% are enabled as minus values.
11	0 to 20mA Bipolar	

Input Terminal [AI2] Polarity Selection (AIV) (C45) data	Function	Description
0	Bipolar (0 to 10 V)	When analog signals are changed to digital values after application of bias, values less than 0% are enabled as minus values.
1	Unipolar (0 to 10 V)	When analog signals are changed to digital values after application of bias, values less than 0% are limited at 0%.

## Offsets (C31, C36, C41)

Set an offset with respect to the analog input voltage/current. It is also possible to correct the offset of signals from external equipment.

## Filter (C33, C38, C43)

Set the filter time constant with respect to the analog input voltage/current. As response slows down when a large time constant is set, take the response speed of the equipment into consideration when determining the time constant. When noise causes the input voltage to fluctuate, increase the time constant.

## Scaling of Analog Input Signal

The relationship between analog input signals and digital values for each individual analog input range is as follows.

Analog input range	Input signal	Digital value (%)	Gain/bias setting value
0 to 10V	0 10V	0% 100%	Gain reference value 100% (factory default value) Gain 100% (factory default value) Bias reference value 100% (factory default value) Bias 0% (factory default value)
-10 to 10V	-10 0 +10V	-100% 0% 100%	Gain reference value 100% (factory default value) Gain 100% (factory default value) Bias reference value 100% (factory default value) Bias 0% (factory default value)
0 to 20mA	0 20mA	0% 100%	Gain reference value 100% (factory default value) Gain 100% (factory default value) Bias reference value 100% (factory default value) Bias 0% (factory default value)
4 to 20mA	4 20mA	0% 100%	Gain reference value 100% (factory default value) Gain 100% (factory default value) Bias reference value 20% Bias 0% (factory default value)

- Analog input signals 0% to 100% are converted at the following full scale, and used by the corresponding functions.

E61, E62, E63 data	Description	Full scale
0	Frequency command	0 to maximum output frequency [Hz]
1	Auxiliary frequency setting 1	Same as above (same as "0: Frequency reference")
2	Auxiliary frequency setting 2	Same as above (same as "0: Frequency reference")
3	PID command	Input Terminal [AI1] Analog Input Adjustment Minimum Scale (C60) to Input Terminal [AI1] Analog Input Adjustment Maximum Scale (C59) in the case of the analog input terminal [AI1]  Input Terminal [AI2] Analog Input Adjustment Minimum Scale (AII) (C66) to Input Terminal [AI2] Analog Input Adjustment Maximum Scale (AII) (C65) in the case of the analog input terminal [AI2] (AII)  Input Terminal [AI2] Analog Input Adjustment Minimum Scale (AIV) (C72) to Input Terminal [AI2] Analog Input Adjustment Maximum Scale (AIV) (C71) in the case of the analog input terminal [AI2] (AIV)
5	PID feedback	Same as above (same as "3: PID command")
6	Ratio setting	0 to 100%
7	Analog torque limiter	0 to 200%
9	Torque bias	Same as above (same as "7: Analog torque limiter")
10	Torque command	0 to 200%
11	Torque Current Command	Same as above (same as "10: Torque command")

E61, E62, E63 data	Description	Full scale
17	Speed limit for forward rotation	0 to maximum output frequency [Hz]
18	Speed limit for reverse rotation	Same as above (same as "17: Speed limit for forward rotation")
20	Analog signal input monitor	(Same as "3: PID command")
21	PID feed forward	(Same as "3: PID command")

## Gain/Bias

When setting gain and bias, take the maximum frequency required for your application to be 100%. When setting the bias base point and gain base point data, take full scale of analog input (10 V or 20 mA) to be 100%.

Even if an analog input is unipolar, the frequency setting can be set as bipolar by setting bias as a negative value. By setting C40 to 10 or 11 at terminal AI2(AII) and setting C45 to 1 at terminal AI2(AIV), the frequency setting can be set as negative polarity by analog inputs of 0 points or less and forward/reverse operation can be possible by only analog commands.

Example) When setting the set frequency 0 to 60 Hz by analog input AI1 1 to 5 V (1st Maximum Output Frequency (F03) = 60 Hz)

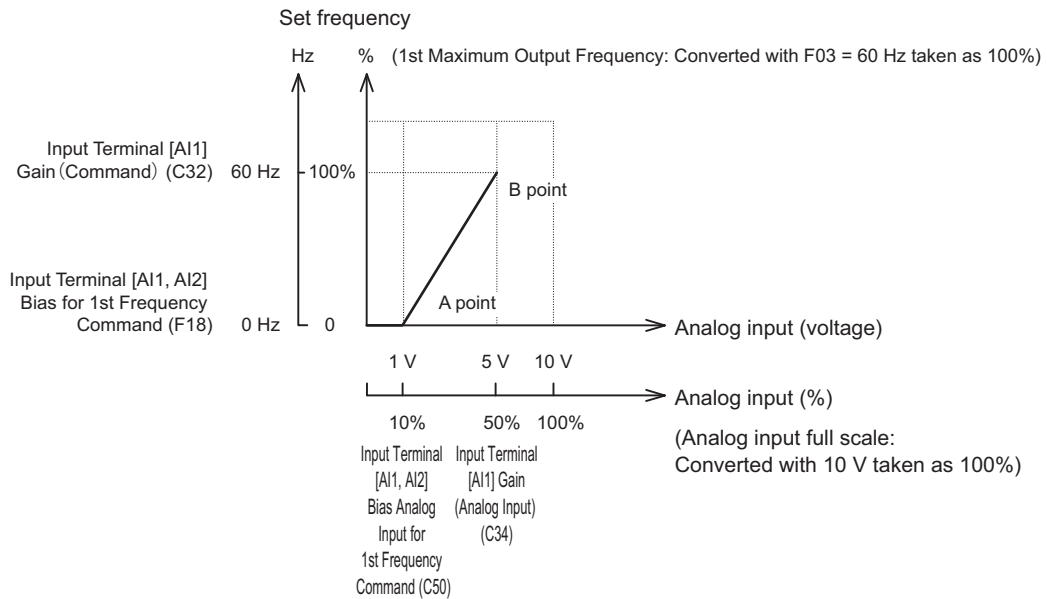

(A point)

To take the frequency reference to be 0 Hz when the analog input is 1 V, set Input Terminal [AI1, AI2] Bias for 1st Frequency Command (F18) to 0%. At this time, as 1 V becomes the bias base point and 1 V is equivalent to 10% of full scale 10 V of terminal AI1, set Input Terminal [AI1, AI2] Bias Analog Input for 1st Frequency Command (C50) to 10%.

(B point)

To take the frequency reference to be the maximum frequency when the analog input is 5 V, set Input Terminal [AI1] Gain (Command) (C32) to 100%. At this time, as 5 V becomes the gain base point and 5 V is equivalent to 50% of full scale 10 V of terminal AI1, set Input Terminal [AI1] Gain (Analog Input) (C34) to 50%.

Input terminal [AI1] can be used with bipolar inputs (-10 V to 10 V) by setting Input Terminal [AI1] Polarity Selection (C35) to "0."

When Input Terminal [AI1, AI2] Bias for 1st Frequency Command (F18) and Input Terminal [AI1, AI2] Bias Analog Input for 1st Frequency Command (C50) are both set to "0," the command becomes symmetrically inverted as shown in the figure below.

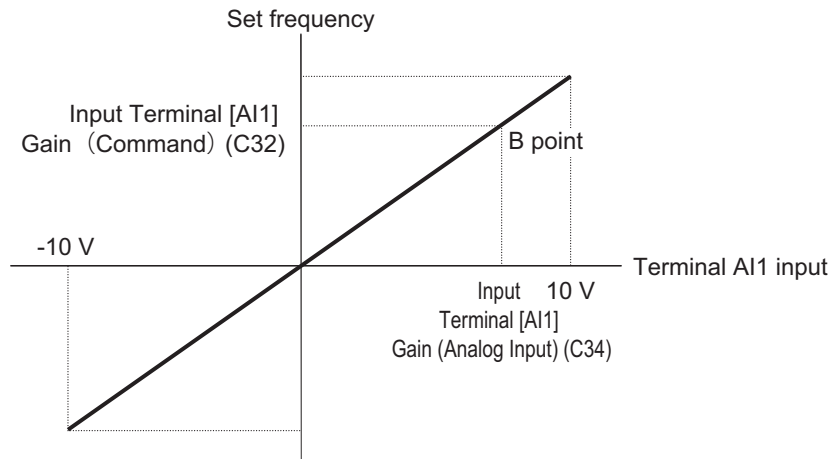

When Input Terminal [AI1, AI2] Bias for 1st Frequency Command (F18) and Input Terminal [AI1, AI2] Bias Analog Input for 1st Frequency Command (C50) are set to an arbitrary value (e.g. points A1, A2, A3), each of the values are limited by bias values as shown in the figure below.

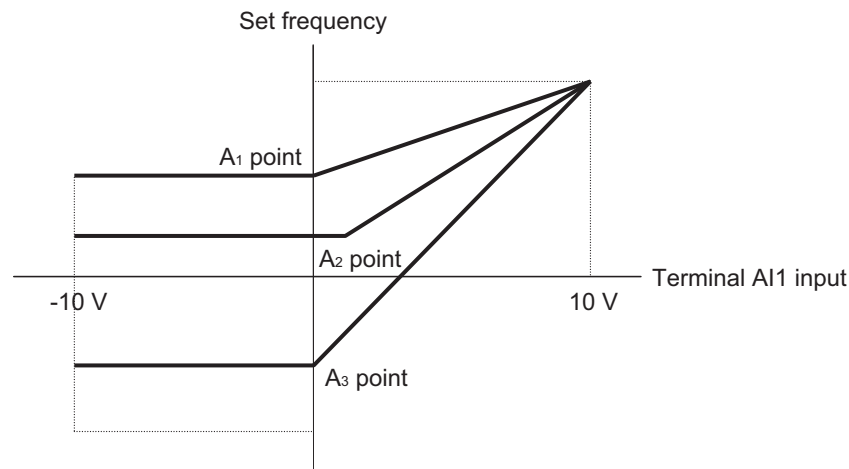

Data can be input as negative polarity by analog inputs of 0 points or less by setting C40 = 10, 11 at input terminal [AI2] (AII), C45 = 0 at input terminal [AI2] (AIV), and the bias value to a negative value.

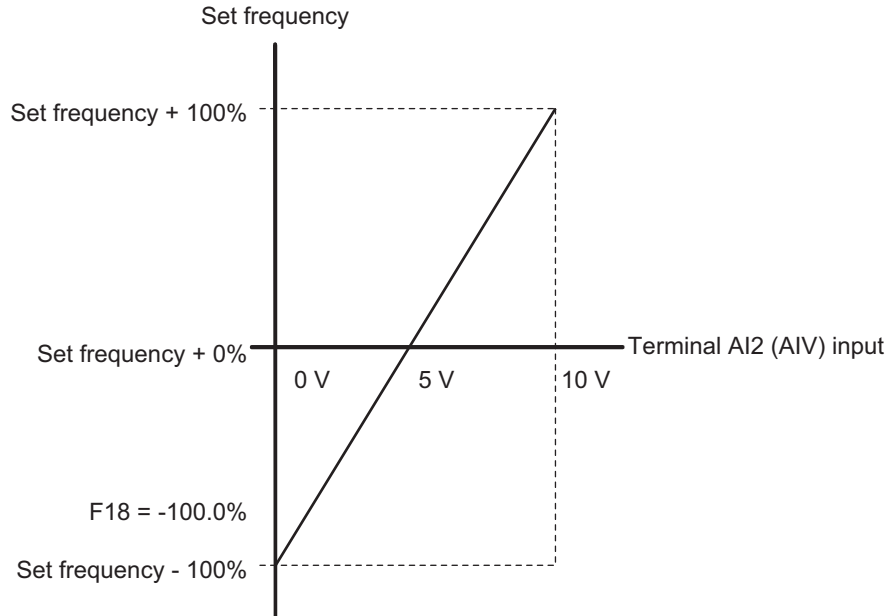

## Normal and Inverse Operations

Normal operation and inverse operation of the analog frequency reference can be switched by the “IVS” terminal (21: Switch normal/inverse operation).

Parameter No.	Function name	Data	Default data	Unit
C53	Input Terminal [AI1, AI2] Normal/Inverse Operation for 1st Frequency Command	0: Normal 1: Inverse	0	-
C54	Input Terminal [AI1, AI2] Normal/Inverse Operation for 2nd Frequency Command	0: Normal 1: Inverse	0	-
E01 to E05, E98, E99	Input Terminal [DI1] to [DI7] Function Selection	21: IVS (Switch normal/inverse operation)	-	-

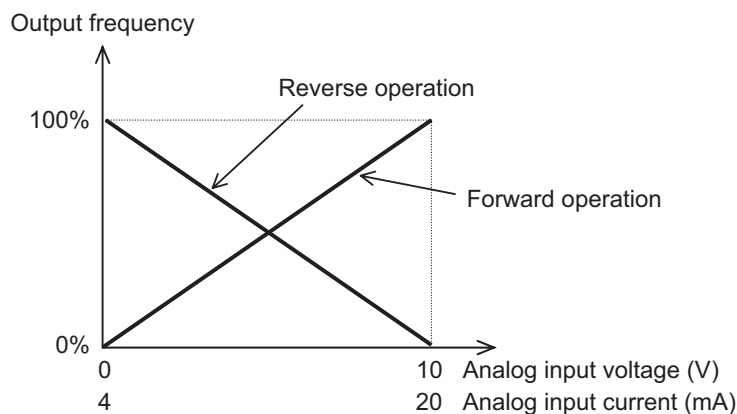

- Switching of Normal/Inverse is performed by the combination of Input Terminal [AI1, AI2] Normal/Inverse Operation for 1st Frequency Command (C53)/Input Terminal [AI1, AI2] Normal/Inverse Operation for 2nd Frequency Command (C54) and the Normal/Inverse switching “IVS” signal. Operation is as shown in the following table.



C53/C54 data	Input signal "IVS"	Operation
0: Normal	OFF	Normal operation
0: Normal	ON	Reverse operation
1: Inverse	OFF	Reverse operation
1: Inverse	ON	Normal operation

Input Terminal [AI1, AI2] Normal/Inverse Operation for 1st Frequency Command (C53)/Input Terminal [AI1, AI2] Normal/Inverse Operation for 2nd Frequency Command (C54) are enabled when analog input is selected as the frequency reference at 1st Frequency Reference Selection (F01)/2nd Frequency Reference Selection (C30). In UP/DOWN control, normal/inverse operation cannot be selected.

### 7-3-3 Analog Input Filter

Use it to set an input filter for voltage or current input when using an external analog signal to input the frequency reference.

The analog input filter is effective in removing noise from the analog input circuit.

Increasing the set value results in a slow response. This is the filter time constant for a sett value of 0.00 to 5.00 (s).

Parameter No.	Function name	Data	Default data	Unit
C33	Input Terminal [AI1] Filter	0.00 to 5.00	0.05	s
C38	Input Terminal [AI2] Filter (All)			
C43	Input Terminal [AI2] Filter (AIV)			

### 7-3-4 Analog Command Hold Function (AHD)

Use this function to hold the frequency reference, PID command, etc. instructed by analog input.

While the AHD terminal is ON, the capture result of the analog input to terminals AI1, AI2 (All) and AI2 (AIV) is held.

Since the three above-described analog input values are held, this function can be used regardless of the usage purpose of the analog inputs.

If the power is turned ON, or if the reset terminal (8: RS) is turned from ON to OFF with the AHD terminal ON, the last held data is made available.

Parameter No.	Function name	Data	Default data	Unit
E01 to E05, E98, E99	Input Terminal [DI1] to [DI7] Function Selection	85: AHD (Analog command held)	-	-
Related function		H402		

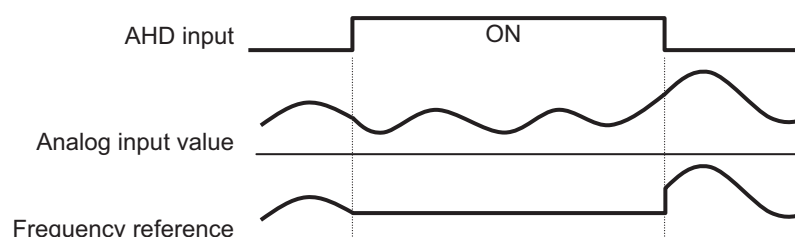

### 7-3-5 Analog Output Function Selection

On this inverter, current output, voltage output and pulse output can be selected.

Analog output terminal [AO] can be switched between voltage output (AOV) (factory default setting), current output (AOI) and pulse output (PO) according to the setting of analog output selector switch (SW5).

Analog output terminal [AO] (AOV)	0 to 10V
Analog output terminal [AO] (AOI)	4 to 20 mA, 0 to 20 mA
Analog output terminal [AO] (PO)	Pulse output

- For details on analog output adjustment, refer to 7-3-6 *Analog Output Adjustment Function* on page 7-48.

Parameter No.	Function name	Data	Default data	Unit
F31	Output Terminal [AO] Function Selection	0: Output frequency1 (before slip compensation) 1: Output frequency2 (after slip compensation) 2: Output current 3: Output voltage 4: Output torque 5: Load ratio 6: Power consumption 7: PID feedback 8: Actual/Estimated speed 9: Main circuit DC voltage 10: Communication data AO 13: Motor output 14: Calibration (+) 15: PID command (SV) 16: PID output (MV) 17: Position error in master-follower operation (Bipolar) 18: Heatsink temperature 21: PG feedback value 27: Thermal load rate 28: Internal Acc/Dec frequency 29: Output torque (Bipolar)	0	-
F29	Output Terminal [AO] Mode Selection	0: Output in voltage (0 to 10 VDC) (SW5 = AOV setting) 1: Output in current (4 to 20mADC) (SW5 = AOI setting) 2: Output in current (0 to 20mADC) (SW5 = AOI setting) 3: Pulse output (SW5 = PO setting)	0	-

### Scaling of Analog Output Signal

The relationship between analog output signals and digital values for each individual analog output range is as follows.

Analog output range	Output signal	Digital value (%)	Gain/bias setting value
0 to 10V	0 10V	0% 100% (full scale value)	Gain reference value 100% (fixed) Gain 100% (factory default value) Bias reference value 0% (fixed) Bias 0% (factory default value)
0 to 20mA	0 20mA	0% 100% (full scale value)	Gain reference value 100% (fixed) Gain 100% (factory default value) Bias reference value 0% (fixed) Bias 0% (factory default value)
4 to 20mA	4 20mA	0% 100% (full scale value)	Gain reference value 100% (fixed) Gain 100% (factory default value) Bias reference value 0% (fixed) Bias 0% (factory default value)

- The values of corresponding functions are converted to analog output 0% to 100% at the following full scale and then output.

F31 data	Description	Full scale
0	Output frequency1 (before slip compensation)	0 to maximum output frequency [Hz]
1	Output frequency2 (after slip compensation)	Same as above
2	Output current	0 to inverter rated output current × 200%
3	Output voltage	0 to 250 V for the 200-V class 0 to 500 V for the 400-V class
4	Output torque	0 to rated motor torque × 200%
5	Load ratio	0 to rated motor load × 2
6	Power consumption	0 to standard applicable electric motor output × 200%
7	PID feedback	0 to 100%
8	Actual/Estimated speed	0 to maximum output frequency [Hz]
9	Main Circuit DC Voltage	0 to 500 V for the 200-V class 0 to 1,000 V for the 400-V class
10	Communication data AO	0 to 20,000
13	Motor output	0 to rated motor output × 200%
14	Calibration (+)	Always full scale
15	PID command (SV)	0 to PID process command 100%
16	PID output (MV)	0 to maximum output frequency [Hz]
17	Position error in master-follower operation (Bipolar)*1	Monitor amount 0% to 50% to 100% Position error -180 to 0 to 180°
18	Heatsink temperature	0 to 200°C
21	PG feedback value	0 to maximum output frequency [Hz]
27	Thermal load ratio	0 to 100% (OL1/OL2 trip level)
28	Internal Acc/Dec frequency	0 to maximum output frequency [Hz]
29	Output torque (Bipolar)*1	Monitor amount 0% to 50% to 100% Rated motor torque × -200% to 0% to 200%

\*1. The output specifications of (signed) data are as described below.

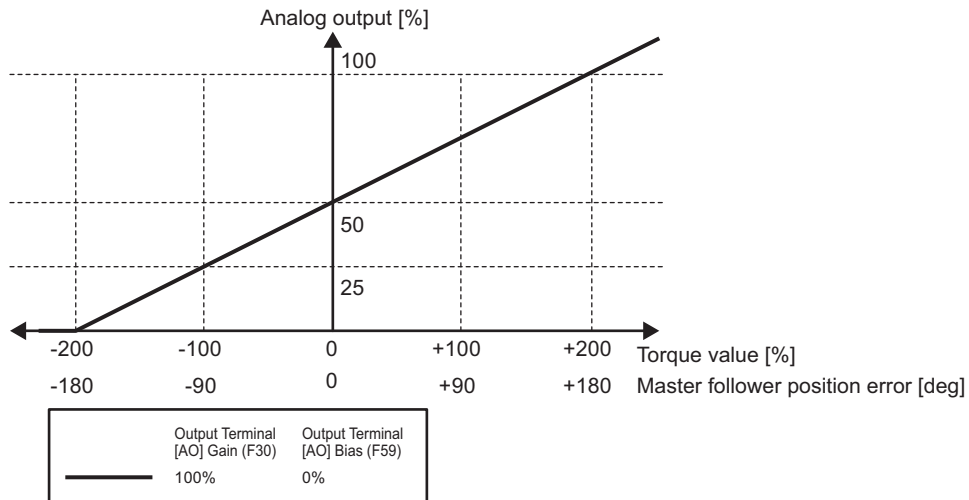

### 7-3-6 Analog Output Adjustment Function

This function adjusts the bias and gain of the analog output terminal [AO]. It is also used for setting the filter and pulse rate.

- In the voltage (AOV)/current (AOI)/pulse (PO) outputs, a filter can be applied to monitor data selected for output. Increasing the set value results in a slow response. This is the filter time constant for a sett value of 0.00 to 5.00 (s).
- In the pulse (PO) output, set the number of pulses when the set monitor output becomes 100% in accordance with the specifications of the counter to be connected, etc.

Parameter No.	Function name	Data	Default data	Unit
F30	Output Terminal [AO] Gain	0 to 300%	100.	%
F59	Output Terminal [AO] Bias	-100.0% to 100%	0.0	%
F58	Output Terminal [AO] Filter	0.00 to 5.00 s	0.00	s
F33	Output Terminal [AO] Pulse Rate (PO)	25 to 32000	1440	p/s

(Example) If a value between 0 and 5 V is output, set the initial data to F59 and 50% to F30.

## 7-4 Restart Functions

This section describes the restart-related functions and their operations.

### 7-4-1 Restart Settings

- Whether or not to perform an auto search start during restart is determined based on the setting of Motor Starting Mode Auto Search Function Selection (H09). If auto search start is not to be performed, the inverter restarts from the starting frequency as in normal operation.
- If “0: Disable” is set at Motor Starting Mode Auto Search Function Selection (H09), then Power Interruption Restart Wait Time (H13) is ignored, and restart is performed from 0 Hz.
- If “2: Enable at normal start and restart after momentary power failure” is selected for Motor Starting Mode Auto Search Function Selection (H09), auto search restart is performed even when the power is turned ON again.
- H09 is a parameter that is used in V/f control (including dynamic torque vector control). Motor Starting Mode Auto Search in Speed Sensor less Vector Control (d67) is used during vector control without speed sensor.
- When vector control with speed sensor is used, restart is performed from the speed detected by the speed sensor regardless of Motor Starting Mode Auto Search Function Selection (H09).
- When using V/f control with speed sensor (including dynamic torque vector control with speed sensor), Motor Starting Mode Auto Search Function Selection (H09) is followed.

Parameter No.	Function name	Data	Default data	Unit
H09	Motor Starting Mode Auto Search Function Selection	0: Disable 1: Enable only at restart after momentary power failure 2: Enable at normal start and restart after momentary power failure	0	-
d67	Motor Starting Mode Auto Search in Speed Sensor less Vector Control		1	-

- The details of Starting Frequency Selection at Frequency Pull-in Restart (E152) are as follows.

Set value	Description	Description
0	Frequency at which the power failure occurred	Pull-in from frequency when inverters output was shut off
1	Maximum frequency	Pull-in from maximum frequency
2	Set frequency	Pull-in from currently selected frequency reference
3	Starting frequency	Restart from starting frequency

### 7-4-2 Restart after Momentary Power Failure

This function is used to set operation selection during restart after a momentary power failure.

Parameter No.	Function name	Data	Default data	Unit
F14	Power Interruption Restart Mode Selection	0: Immediately trip (Free run stop) 1: Trip after a recovery from power failure (Free run stop) 2: Trip after decelerate-to-stop 3: Continue to run 4: Restart at the frequency selected by (E152) 6: Decelerate-to-stop (w/o trip)	1	-
E01 to E05, E98, E99	Input Terminal [DI1] to [DI7] Function Selection	26: STM (Enable auto search for idling motor speed at starting) 22: IL (Interlock)	-	-
H09	Motor Starting Mode Auto Search Function Selection	0: Disable 1: Enable only at restart after momentary power failure	0	-
d67	Motor Starting Mode Auto Search in Speed Sensor less Vector Control	2: Enable at normal start and restart after momentary power failure		
H16	Allowable Time for Power Interruption Restart	0.0 to 30.0 999: Auto judgment by the inverter	999	s
H13	Power Interruption Restart Wait Time	0.1 to 100.0	0.5	s
H14	Deceleration Setting During Current Limit for Restart Mode after Power Interruption	0.00: Selected deceleration time 0.01 to 100.00 999: According to current limiter	999	Hz/s
H15	Continuous Running Voltage Level	200 to 300: (200 V class series) 400 to 600: (400 V class series)	235	V
H49	Auto Search Delay Time 1 for Starting Characteristic	0.0 to 10.0	0.0	s
H46	Auto Search Delay Time 2 for Starting Mode	0.1 to 100.0	1.0	s
H92	Continuous Running at the Momentary Power Failure P Proportional Gain	0.000 to 10.000 999: Auto	999	time
H93	Continuous Running at the Momentary Power Failure Integral Time	0.010 to 10.000 999: Auto	999	s
E152	Starting Frequency Selection at Frequency Pull-in Restart	0: Frequency at which the power failure occurred 1: Maximum output frequency 2: Reference frequency 3: Starting frequency	3	-

## Power Interruption Restart Mode Selection (F14)

F14 data	Operation details	
	Without auto search	With auto search*1
0: Immediately trip	If a momentary power failure occurs while the inverter is operating and an undervoltage is detected in the Main Circuit DC Voltage of the inverter, the undervoltage alarm LU is output at that time, the inverter output is cut off and the motor enters the free-run state.	
1: Trip after a recovery from power failure	If a momentary power failure occurs while the inverter is operating and an undervoltage is detected in the Main Circuit DC Voltage of the inverter, the inverter output is cut off at that time and the motor enters the free-run state, but no undervoltage alarm is generated. During power restoration from a momentary power failure, an undervoltage alarm LU is output.	
2: Trip after decelerate-to-stop	If a momentary power failure occurs while the inverter is operating and the Main Circuit DC Voltage of the inverter falls below the continuous running level, the deceleration stop control is started. During deceleration stop control, the kinetic energy of the moment of inertia of the load is regenerated due to deceleration, and the deceleration operation continues. After the deceleration stop, the LU alarm is output.	
3: Continue to run	If a momentary power failure occurs while the inverter is operating and the Main Circuit DC Voltage of the inverter falls below the continuous running level, the operation continuation control is started. During continuous running control, the kinetic energy of the moment of inertia of the load is regenerated due to deceleration, and the operation continues and power restoration is awaited. If the energy to be regenerated is low and an undervoltage is detected, the inverter output is cut off, and the motor falls in a free-run state.	
	If the RUN command is input during power restoration, restart is performed from the pull-in frequency. Select the pull-in frequency at Starting Frequency Selection at Frequency Pull-in Restart (E152).	If the RUN command is input during power restoration, auto search is performed, the motor speed is estimated, and restart is performed from the frequency.
4: Restart at the frequency	If a momentary power failure occurs while the inverter is operating and an undervoltage is detected in the Main Circuit DC Voltage of the inverter, the inverter output is cut off and the motor enters the free-run state.	
	If the RUN command is input during power restoration, restart is performed from the pull-in frequency. Select the pull-in frequency at Starting Frequency Selection at Frequency Pull-in Restart (E152).	If the RUN command is input during power restoration, auto search is performed, the motor speed is estimated, and restart is performed from the frequency.
6: Decelerate-to-stop(w/o trip)	If a momentary power failure occurs while the inverter is operating and the Main Circuit DC Voltage of the inverter falls below the continuous running level, the deceleration stop control is started. During deceleration stop control, the kinetic energy of the moment of inertia of the load is regenerated due to deceleration, and the deceleration operation continues. An alarm does not occur after a deceleration stop. If the RUN command turns OFF in the deceleration stop state, the deceleration stop state is canceled, and the operation can be performed when the RUN command turns ON the next time.	

- \*1. With auto search is selected when Enable auto search for idling motor speed at starting "STM" is ON, or Motor Starting Mode Auto Search Function Selection (H09/d67) = 1 or 2.  
When a motor control method with speed sensor is selected, restart is performed from the motor speed detected by the speed sensor. In the case of a motor control method without speed sensor, restart is performed from the estimated speed.



### Additional Information

When using vector control without speed sensor, do not use restarting from the pull-in frequency (Starting Frequency Selection at Frequency Pull-in Restart (E152)). If you select starting from pull-in frequency, normal start may not be performed, or the device may be damaged.

## Startup Characteristics Selection STM

Allocate “26: STM (Enable auto search for idling motor speed at starting)” to Input Terminal [DI1] to [DI7] Function Selection (E01 to E05, E98, E99).

This function is used to select whether or not to perform the auto search operation (auto search without stopping the motor during idling) when the inverter is started by turning the STM terminal ON or OFF.

Startup characteristics selection STM	Operation
OFF	Auto search disabled
ON	Auto search enabled

By a startup with auto search enabled, the speed at startup will be searched (for a maximum of approx. 1.2 seconds) as an auto search without stopping the motor during idling is performed. After a speed search, acceleration is performed up to the set frequency in accordance with the set acceleration time.

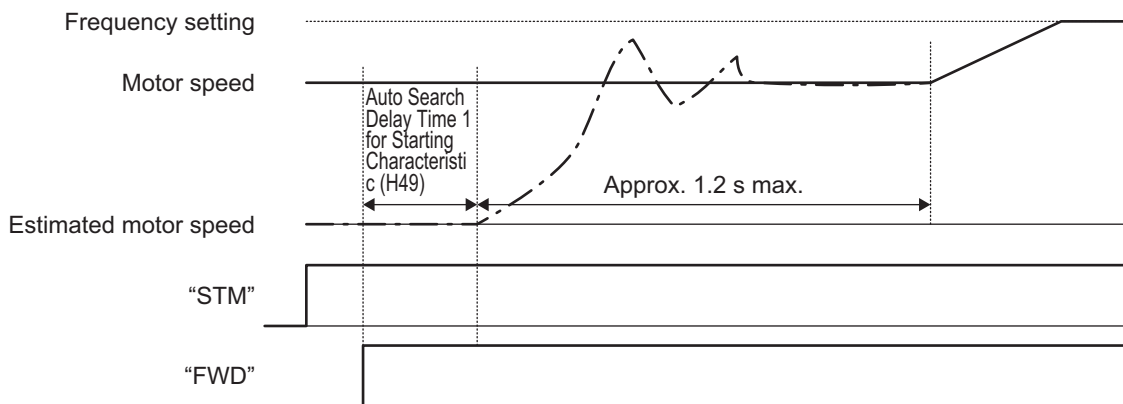

At a startup as a result of the RUN command turning ON, the auto search is started after a delay by the time set at Auto Search Delay Time 1 for Starting Characteristic (H49). When control of a motor is alternately switched between two inverters, and the motor is started by an auto search after a free run during switching, the RUN command does not need to be issued in a timely manner by setting H49.

## Restart Mode after Momentary Power Failure (Basic Operation: Without Auto Search Setting)

When the inverter detects that the Main Circuit DC Voltage has dropped below the undervoltage level during operation, it judges a momentary power failure.

After the restoration of power, the inverter is set to the operation ready completion state once the initial charging time has elapsed.



During a momentary power failure, the power of the external circuit (such as a relay circuit) controlling the inverter also declines and the RUN command may also turn OFF. Therefore, when the operation ready state is complete, the inverter waits for two seconds for the RUN command to be input. If the input of the RUN command is confirmed within two seconds, the inverter starts restarting according to Power Interruption Restart Mode Selection (F14). If the RUN command is not input, the restart mode after momentary power failure is canceled, and startup is performed from the normal starting frequency.

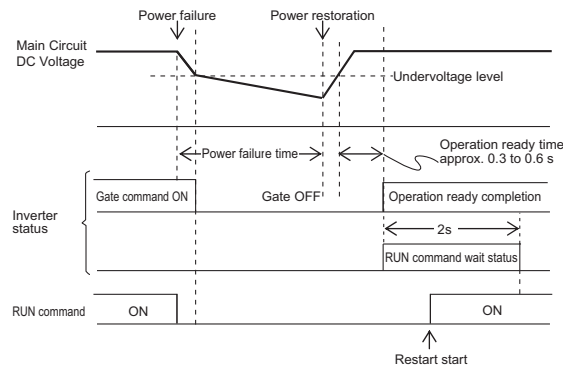

During power restoration, the inverter waits for two seconds for the RUN command to be input, but if the time period set at Allowable Time for Power Interruption Restart (H16) elapses after power failure is judged, the two-second long RUN command input waiting state is canceled, and normal startup is performed.

If the free-run command “FRS” is input during a power failure, Free Run Stop Restart Operation Selection (H441) is set, and when the RUN command is input, startup is performed from the normal starting frequency.

As a measure against difficulty in bringing down the Main Circuit DC Voltage during momentary power failure, if “22: IL (Interlock)” is allocated to Input Terminal [DI1] Function Selection to Input Terminal [DI7] Function Selection (E01 to E05, E98, E99), the momentary power failure can be detected accurately.

Input signal IL	Meaning
OFF	Momentary power failure not occurred
ON	Momentary power failure occurred (Restart after momentary power failure enabled)

When the motor speed drops during momentary power failure and startup is performed from the frequency prior to the momentary power failure after the power is restored, the current limitation function is activated, and the output frequency of the inverter declines automatically. When the output frequency and the motor rotation speed are synchronous, acceleration is performed up to the original output frequency.

However, the momentary overcurrent limitation must be enabled (Instantaneous Overcurrent Limiting Function Selection (H12) = 1) for the synchronous pull-in of the motor.

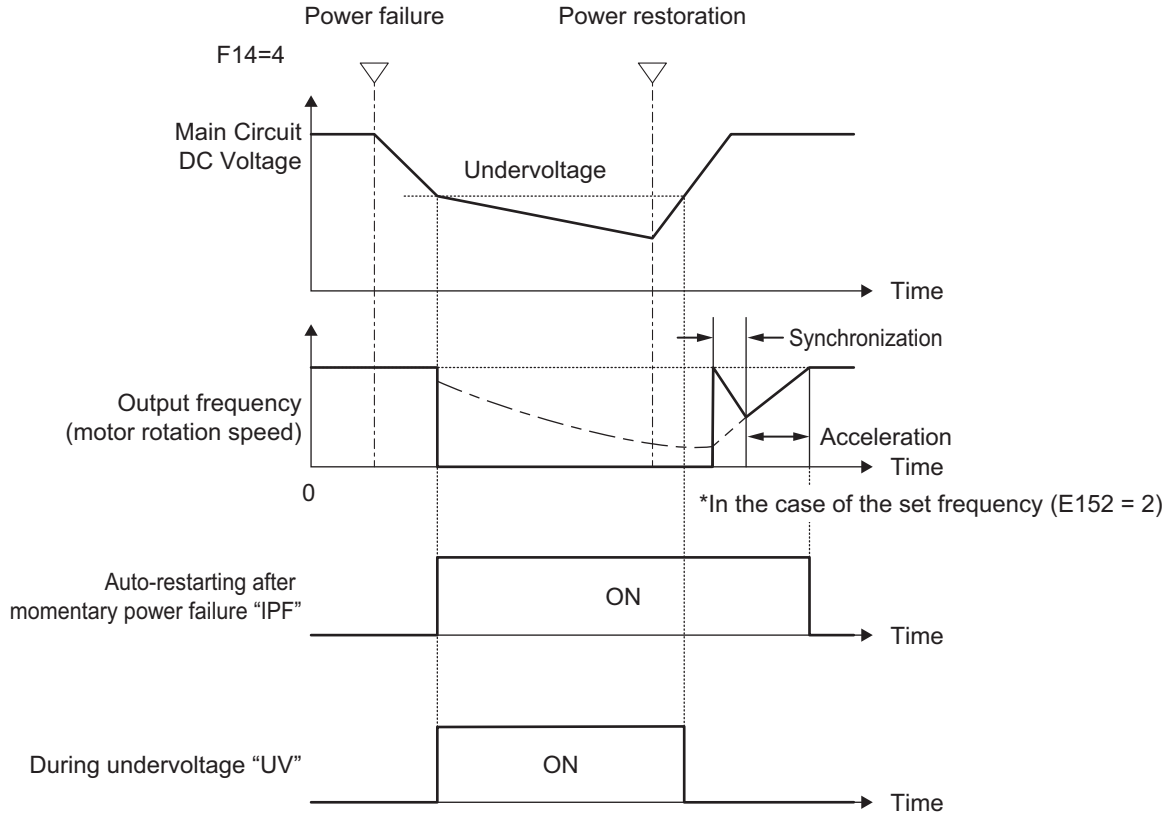

### Restart Mode after Momentary Power Failure (Basic Operation: With Auto Search Setting)

The auto search operation does not operate normally if residual voltage is remaining in the motor. Therefore, it is necessary to secure time for the residual voltage to dissipate.

The required time for restart after momentary power failure is secured by Auto Search Delay Time 2 for Starting Mode (H46).

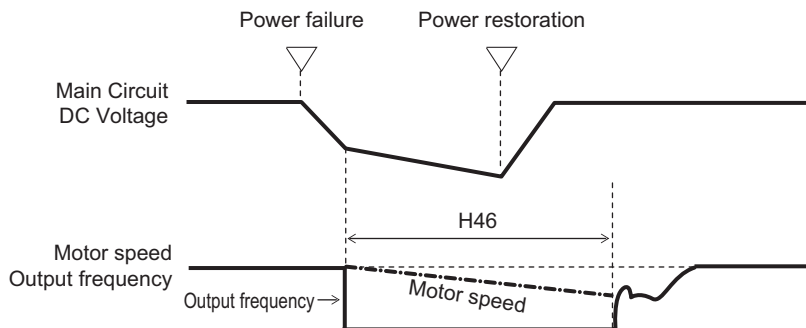

## Allowable Time for Power Interruption Restart (H16)

Set the maximum time from when a momentary power failure (undervoltage level) occurs until a restart is performed (setting range: 0.0 to 30.0 s). If the setting range is exceeded, the restart after momentary power failure is not performed, and operation is performed by turning ON the power again.

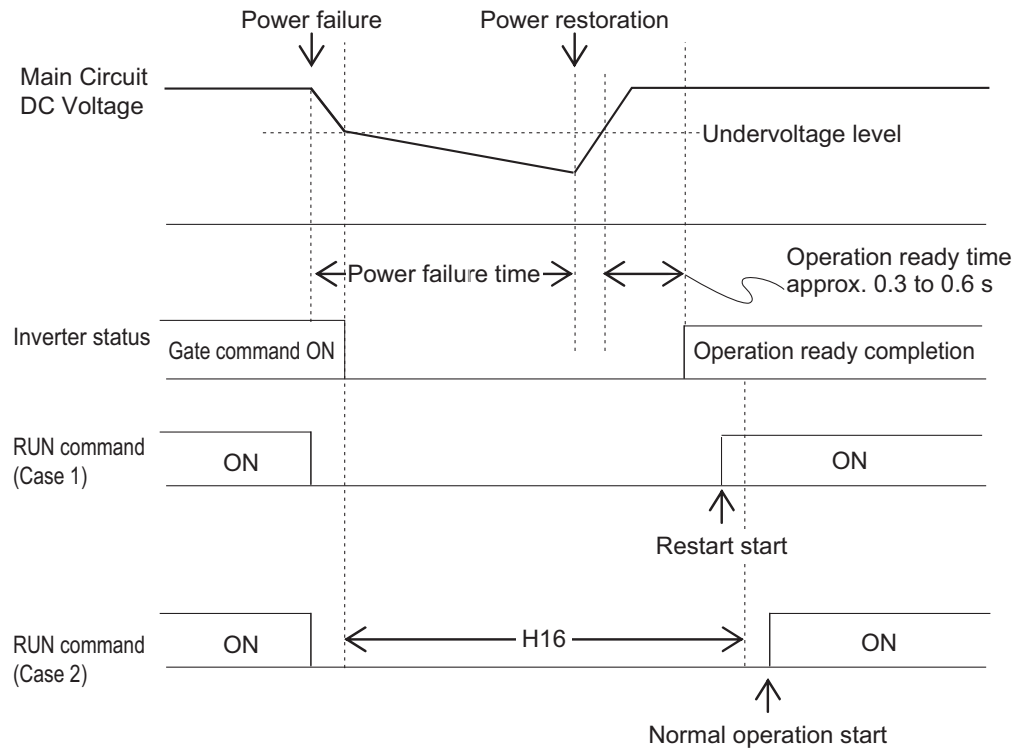

If Allowable Time for Power Interruption Restart (H16) is set to “999,” restart after momentary power failure is performed until the Main Circuit DC Voltage drops down to the allowable voltage for restart after momentary power failure, and once it becomes equal to or below the allowable voltage for restart after momentary power failure, it is judged that the power supply is cut off, the restart after momentary power failure is not performed, and the operation is performed by turning the power ON again.

Power supply system	Allowable voltage for restart after momentary power failure
200 V	50 V
400 V	100 V

## Power Interruption Restart Wait Time (H13)

Set the time from after the occurrence of momentary power failure until the inverter restarts (Auto Search Delay Time 2 for Starting Mode (H46) is used during auto search setting). If the inverter is started in a state when the residual voltage of the motor is high, the inrush current may increase, there may be a temporary regeneration, and an overvoltage alarm may occur. For safety, adjust Power Interruption Restart Wait Time (H13) so that restart is performed after the residual voltage becomes low to an extent.

## Deceleration Setting During Current Limit for Restart Mode after Power Interruption (H14)

During restart after a momentary power failure, if the output frequency of the inverter and the rotation speed of the motor are not in sync, an overcurrent flows and current limitation is activated. If a current limitation is detected, the output frequency is automatically lowered to be in sync with the motor rotation speed. At Deceleration Setting During Current Limit for Restart Mode after Power Interruption (H14), set the gradient (frequency fall rate (Hz/s)) for lowering the output frequency.

H14 data	Output frequency lowering operation
0.00	Falls at the selected deceleration time.
0.01 to 100.00 Hz/s	Falls at the fall rate set at Deceleration Setting During Current Limit for Restart Mode after Power Interruption (H14).
999	Falls in accordance with the PI controller of the current limitation process (the PI constant is a fixed value inside the inverter).

## Continuous Running Voltage Level (H15)

- Deceleration stop during momentary power failure  
 If “Trip after decelerate-to-stop (Power Interruption Restart Mode Selection (F14) = 2)” or “Decelerate-to-stop(w/o trip) (Deceleration Setting During Current Limit for Restart Mode after Power Interruption (F14) = 6)” is selected at the Power Interruption Restart (mode selection), then at the moment a momentary power failure occurs while the inverter is operating and the Main Circuit DC Voltage of the inverter falls below the continuous running level, the deceleration stop control is started. Adjust the Main Circuit DC Voltage level at which to start the deceleration stop control at Continuous Running Voltage Level (H15). During deceleration stop control, deceleration is performed while controlling the Main Circuit DC Voltage at a constant level with a PI controller. The P (Proportional) and I (Integral) of the PI controller are adjusted by Continuous Running at the Momentary Power Failure P Proportional Gain (H92) and Continuous Running at the Momentary Power Failure Integral Time (H93), respectively.
- Continuous running  
 If “Continue to run (Power Interruption Restart Mode Selection (F14) = 3)” is selected at the Power Interruption Restart (mode selection), then at the moment a momentary power failure occurs while the inverter is operating and the Main Circuit DC Voltage of the inverter falls below the continuous running level, the operation continuation control is started. Adjust the continuous running level at which to start the continuous running control at Continuous Running Voltage Level (H15). During continuous running control, the operation is continued while controlling the Main Circuit DC Voltage at a constant level with a PI controller.

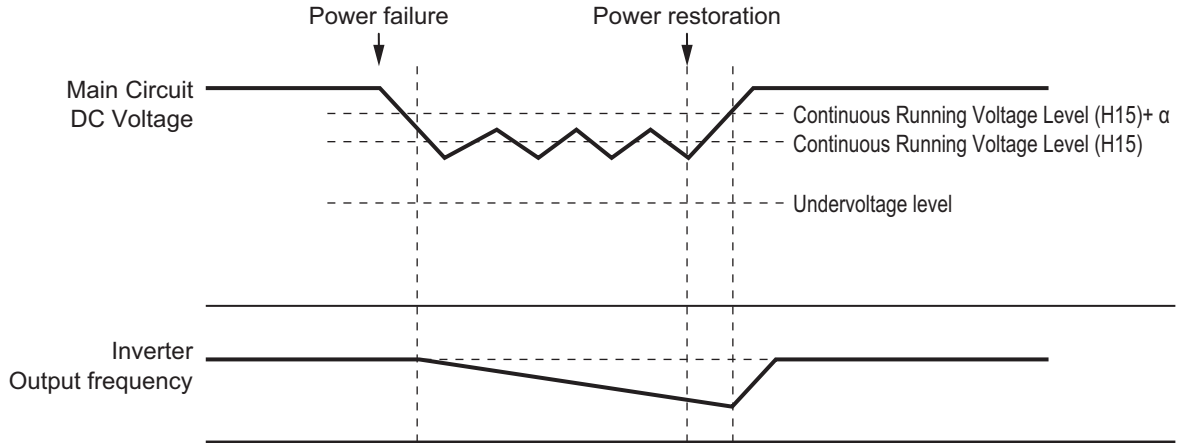

Power supply system	α	
	22 kW max.	30 kW min.
200 V	5 V	10 V
400 V	10 V	20 V

- During decelerating at momentary power failure “IPF2”  
 This parameter turns ON when Power Interruption Restart Mode Selection (F14) is 2 or 3, and the Main Circuit DC Voltage falls below Continuous Running Voltage Level (H15) and the continuous running state is established. This parameter turns OFF when power restores and the Main Circuit DC Voltage becomes “the voltage set in H15 +10 V or higher.”  
 This parameter turns ON even when Power Interruption Restart Mode Selection (F14) is 4 or 5 and the Main Circuit DC Voltage falls below the undervoltage level. This parameter turns OFF when the DC link bus voltage reaches “the undervoltage level +10 V or higher.”

Parameter No.	Function name	Data	Default data	Unit
E20, E21, E27	Output Terminal [DO1] Function Selection, Output Terminal [DO2] Function Selection, Output Terminal [ROA, ROB] Function Selection	79: IPF2 (During decelerating at momentary power failure)	-	-

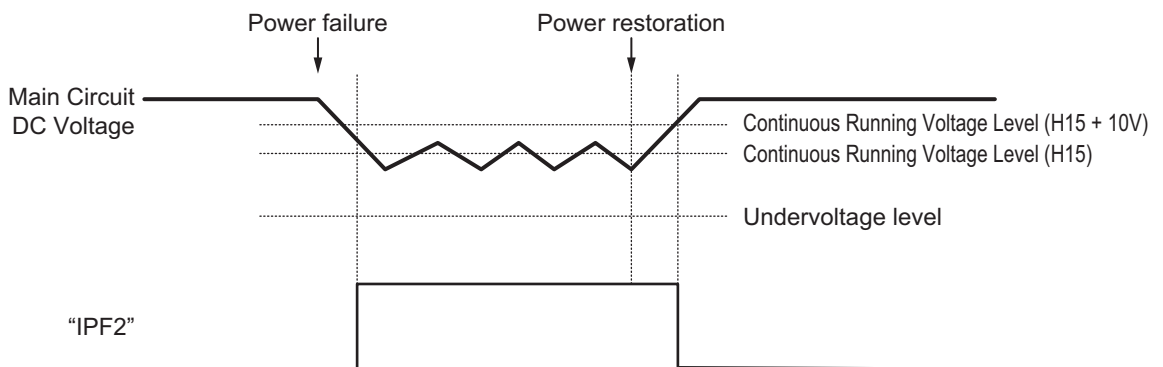

### 7-4-3 Trip Retry Operation

This function is used to set the operation selection to trip retry.

Parameter No.	Function name	Data	Default data	Unit
E139	Overvoltage/Overcurrent Restart Function Selection	0: Trip 4: Restart at the frequency selected by E152	0	-
H04	Retry Count at Trip	0: Disable 1 to 20: Number of retries	0	Times
H05	Retry Standby Time at Trip	0.5 to 20.0	5.0	s
E20, E21, E27	Output Terminal [DO1] Function Selection, Output Terminal [DO2] Function Selection, Output Terminal [ROA, ROB] Function Selection	26: TRY (Auto-resetting)	-	-

#### Overvoltage/Overcurrent Restart Function Selection (E139)

E139 data	Operation details	
	Without auto search	With auto search*1
0: Trip	An alarm is output when an overvoltage or overcurrent is detected, the inverter output is cut off, and the motor falls in a free-run state.	
4: Restart based on pull-in frequency	If an overvoltage or overcurrent is detected, the inverter output is cut off, and the motor falls in a free-run state.	
	During recovery from overvoltage or overcurrent, restart is performed from the pull-in frequency. Select the pull-in frequency in E152.	During recovery from overvoltage or overcurrent, auto search is performed, the motor speed is estimated, and restart is performed from the frequency.

- \*1. With auto search is selected when Enable auto search for idling motor speed at starting "STM" is ON, or H09 (d67) = 2.  
When a motor control method with speed sensor is selected, restart is performed from the motor speed detected by the speed sensor. In the case of a motor control method without speed sensor, restart is performed from the estimated speed.



#### Additional Information

When using vector control without speed sensor, do not use restarting from the pull-in frequency (Starting Frequency Selection at Frequency Pull-in Restart (E152)). If you select starting from pull-in frequency, normal start may not be performed, or the device may be damaged.

Use the retry function to recover from overvoltage or overcurrent.

(H04: Retry Count at Trip, H05: Retry Standby Time at Trip)

As for the starting method, the settings in E139 is applied.

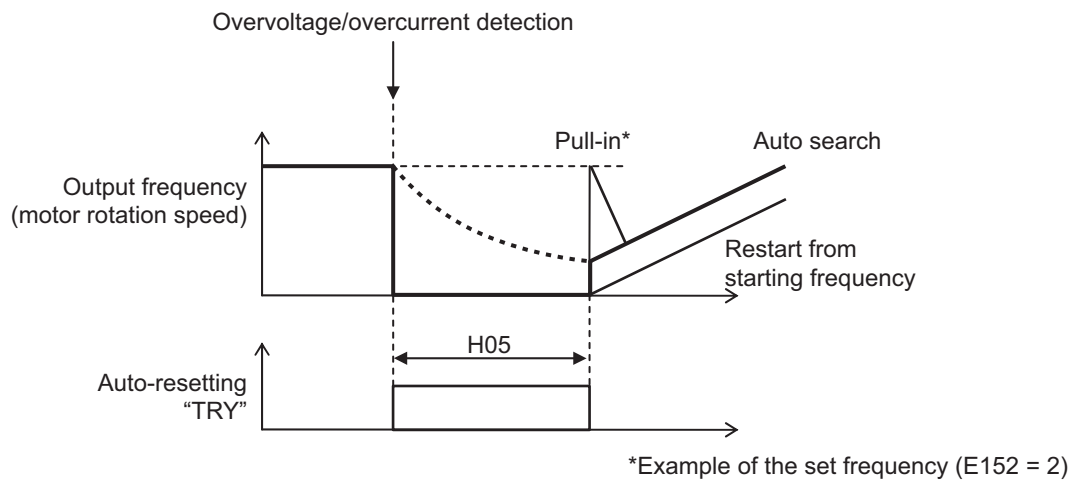

### 7-4-4 Unattended Start Protection (USP Terminal)

- Use this function to have the inverter trip if the power supply is turned ON with the RUN command ON in the inverter.
- When the RUN command is ON and multifunction input “USP” is ON when the power is ON, a run operation error (alarm code: Er6, sub code: 30) is generated
- When the Er6 alarm is reset with the RUN command still ON, operation is started regardless of the ON/OFF setting of “USP.” (Example 1)
- If the RUN command turns ON after the power supply is turned ON, the inverter operates normally. (Example 2)
- Power recovery restart prevention based on USP input is enabled only for a RUN command from the terminal block.

Parameter No.	Function name	Data	Default data	Unit
E01 to E05, E98, E99	Input Terminal [DI1] to [DI7] Function Selection	186: USP (Unattended start protection)	-	-

The operation of the power recovery restart prevention function is shown below.

(Example 1) Power ON with RUN command ON (Reset with Reset (RS))

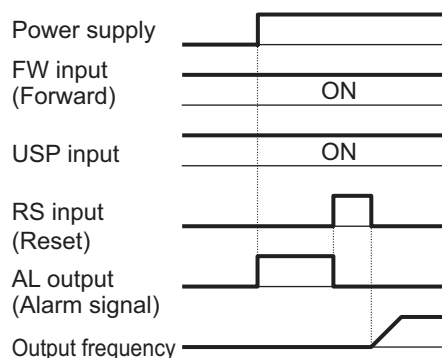

(Example 2) RUN command after power ON (Normal operation)

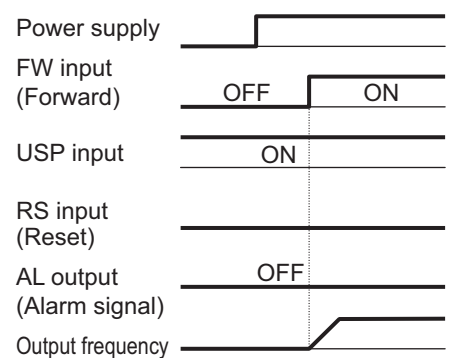

## Using the Power Recovery Restart Prevention Function and the Start Check Function in Combination

- When used in combination with the start check function (H96 = 2, 3), a run operation error (alarm code: Er6, sub code: 5) is generated by the start check function, and this is given priority. For this reason, to cancel the run operation error, turn the RUN command OFF and then perform a reset operation.
- For details on the start check function, refer to 7-7-7 *STOP Key Priority/Start Check Function* on page 7-80.

### 7-4-5 Free Run Restart

- A restart is performed when the operation state is returned to while in a free-run state.
- A free-run restart is performed by the restart operation selected at Free Run Stop Restart Operation Selection (H441) when “1: Free run stop” is selected at Stop Selection (H11) and the RUN command is turned ON while in a free-run state or when the free-run command (7: FRS) terminal is set to OFF and the free-run state is canceled.
- Note, however, that when RUN Command Selection (F02/E102) is set to “0, 2, 3: Operator,” a restart is not performed even if the free-run command (7: FRS) terminal is canceled.
- For details on a restart after a momentary power failure, refer to 7-4-2 *Restart after Momentary Power Failure* on page 7-49.

Parameter No.	Function name	Data	Default data	Unit
H441	Free Run Stop Restart Operation Selection	0 to 2 0: Normal start 1: Starting with matching frequency 2: Starting with active matching frequency	2	-
H13	Power Interruption Restart Wait Time	0.1 to 100.0	0.5	s
H46	Auto Search Delay Time 2 for Starting Mode	0.1 to 100.0	Dependent on capacity	s
F23/A12	1st Starting Frequency/2nd Starting Frequency	0.0 to 60.0	0.5	Hz
H14	Deceleration Setting During Current Limit for Restart Mode after Power Interruption	0.00: Selected deceleration time 0.01 to 100.00 Hz/s 999: According to current limiter	999	Hz/s
E152	Starting Frequency Selection at Frequency Pull-in Restart	0: Frequency at which the power failure occurred 1: Maximum output frequency 2: Reference frequency 3: Starting frequency	3	-
H440	Free Run Stop Restart Allowable Time	0.0 to 30.0 s	30.0	s



Parameter No.	Function name	Data	Default data	Unit
E01 to E05, E98, E99	Input Terminal [DI1] to [DI7] Function Selection	7: FRS (Free-run stop) 26: STM (Enable auto search for idling motor speed at starting)	-	-

### For Normal Start (H441 = 0: Normal Start)

- Note that by a restart from the starting frequency (E152=3), the inverter operates suddenly while the motor is operating by inertia. Use this setting if the motor stops soon due to the load after a free-run stop.

### Auto Search Restart (H441 = 1: Auto Search Restart)

- Auto search restart causes the inverter to anticipate the frequency from the voltage between the motor terminals in a free-run state and restart matched to that frequency. If the anticipated frequency is not sufficient, the inverter restarts from 1st Starting Frequency (F23)/2nd Starting Frequency (A12).
- With the RUN command ON, when the free-run state is canceled after the Auto Search Delay Time 2 for Starting Mode (H46) has elapsed since the free-run state, the auto search restart is started.
- The restart is performed at the starting frequency when Free Run Stop Restart Allowable Time (H440) is set shorter than Auto Search Delay Time 2 for Starting Mode (H46).
- The examples below assume that the FRS terminal is used.

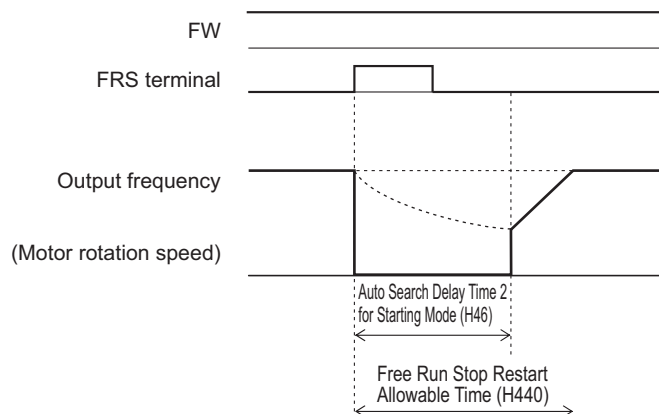

- When the anticipated frequency exceeds the Maximum Output Frequency (F03/A01) or the Frequency Upper Limit (F15/E117), auto search restart is not performed, and the restart is performed using the maximum frequency or the Frequency Upper Limit (F15/E117), whichever is lower.

### Frequency Pull-in Restart (H441 = 2: Starting with Active Matching Frequency)

- A frequency pull-in restart refers to the method of performing acceleration again to restart when the frequency reference is output to the motor in a free-run state, and the frequency reference is decelerated by current limit until there is no longer a current limit. This enables a smooth restart independent of the voltage between motor terminals. Use this setting when the inverter is in free-run state for a long time due to a large load inertia.

- With the RUN command ON, when the free-run state is canceled after the Power Interruption Restart Wait Time (H13) has elapsed since the free-run state, the frequency selected by Starting Frequency Selection at Frequency Pull-in Restart (E152) is output and the frequency pull-in restart is performed.
- The examples below assume that the FRS terminal is used.

Example) When Starting Frequency Selection at Frequency Pull-in Restart (E152) = "0: Frequency at which the power failure occurred"

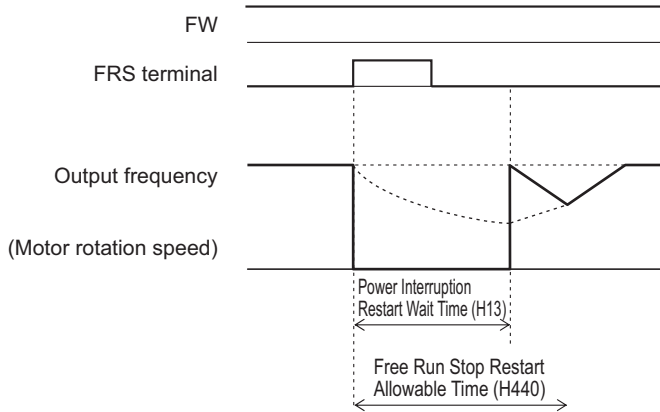

Example) When Starting Frequency Selection at Frequency Pull-in Restart (E152) = "3: Starting frequency"

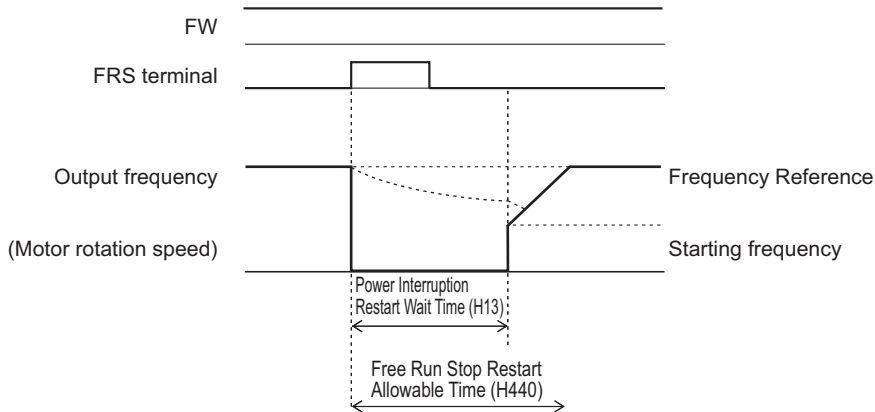

## 7-5 DC Injection Braking Function

This section describes the DC injection braking function.

### 7-5-1 DC Injection Braking (DB)

Use this function to have the motor apply DC injection braking according to the load.

For an induction motor, this function allows braking with no feedback of regenerated energy to the inverter.

However, for a PM motor, consider to take measures against overvoltage because even the DC injection braking function allows regenerated energy to be fed back to the inverter.

DC injection braking can be controlled with one of the following three methods:

- Setting “13: DB (External DC injection braking)” to Input Terminal [DI1] to [DI7] Function Selection (E01 to E05, E98, E99) and turning ON/OFF the terminal to which the external DC injection braking function is allocated.
- Setting DC Injection Braking Selection (E114) and controlling the motor by parameter settings.
- Setting DC Injection Braking Selection (E114) and controlling the motor only by comparison via the frequency set in the parameter.

Note, however that the use of DC injection braking may not cause the motor to stop due to the moment of inertia of the motor load.

DC injection braking is disabled when the torque control, position control and servo lock is enabled.

Parameter No.	Function name	Data	Default data	Unit
E114	DC Injection Braking Selection	0 to 2 0: External DC injection braking 1: External DC injection braking/ setting frequency 2: Setting frequency	0	-
F20/A09	1st DC Injection Braking Start Frequency/2nd DC Injection Braking Start Frequency	0.0 to 60.0	0.0	Hz
F21/A10	1st DC Injection Braking Level/2nd DC Injection Braking Level	0 to 100 0 to 100% (HHD mode) 0 to 80% (HND/HD mode) 0 to 60% (ND mode) Based on inverter rated current	0	%
F22/A11	1st DC Injection Braking Time/2nd DC Injection Braking Time	0.00; 0.01 to 30.00 s 0.00: Disable 0.01 to 30.00 s	0.00	s
H95	DC Injection Braking Start Characteristic Selection	0; 1 0: Slow response 1: Quick response	1	-
E115	External DC Injection Braking Edge/Level Selection	0; 1 0: Edge operation 1: Level operation	1	-
E116	Startup DC injection braking	0 to 100% (HHD mode) 0 to 80% (HND mode)	0	-

Parameter No.	Function name	Data	Default data	Unit
H195	DC Injection Braking Start-up Time	0.00: Disable 0.01 to 30.00 s Only motor 1 is effective	0	s
E01 to E05, E98, E99	Input Terminal [DI1] to [DI7] Function Selection	13: DB (External DC injection braking)		

- When operation is started, DC injection braking operation is canceled and normal operation is started.
- If the RUN command is turned ON during DC injection braking, DC injection braking is canceled and normal operation is started.

### DC Injection Braking by DB Terminal (E114 = “0: External Terminal,” “1: External DC Injection Braking/Setting Frequency”)

- DC injection braking can be applied by the DB terminal (13: External DC injection braking). Set “13: DB (External DC injection braking)” to Input Terminal [DI1] Function Selection to Input Terminal [DI7] Function Selection (E01 to E05, E98, E99).
- When “2: Setting frequency” is selected for DC Injection Braking Selection (E114), DC injection braking by DB terminal (13: External DC injection braking) is disabled.
- When “1: External DC injection braking/setting frequency” is selected for DC Injection Braking Selection (E114), this setting is given priority over DC injection braking by DC Injection Braking Start Frequency (F20/A09).
- When “0: Edge operation” is selected for External DC Injection Braking Edge/Level Selection (E115), DC injection braking operates only for the time period set in the DC Injection Braking Time (F22/A11) from the rising edge of the DB terminal.

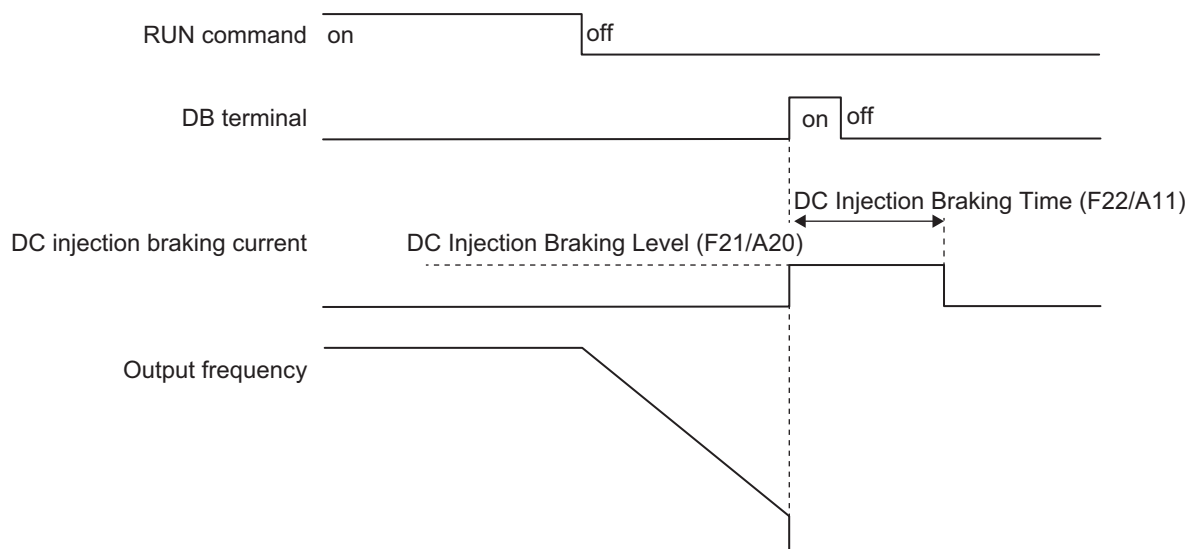

- When “1: Level operation” is selected for External DC Injection Braking Edge/Level Selection (E115), DC injection braking operates while the DB terminal (13: External DC injection braking) is ON.

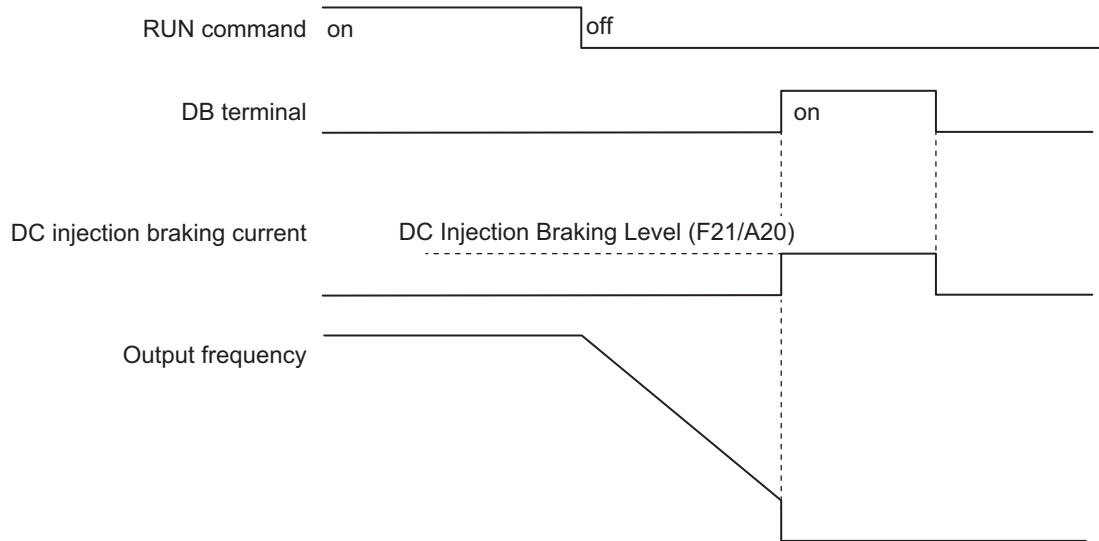

- When the RUN command is ON, run operation is given priority. Even if the DB terminal is turned ON while the RUN command is ON, DC injection braking is not started. If the RUN command is turned ON during DC injection braking, DC injection braking is stopped and operation is started.

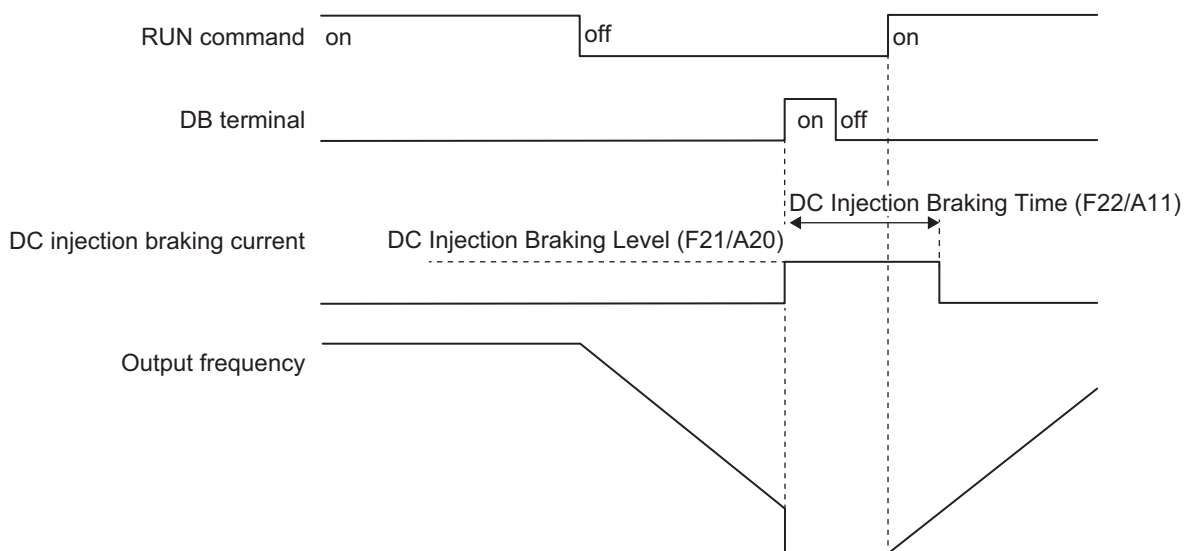

Also, the DB terminal turns ON while the RUN command is ON, thereafter, even if the RUN command turns OFF, the DC injection braking does not start.

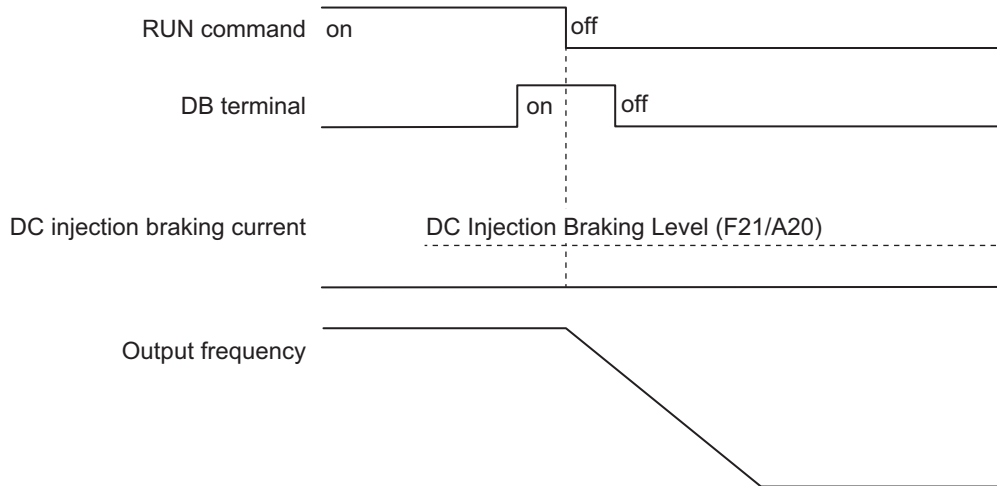

### DC Injection Braking Start at Output Frequency (E114 = "1: External DC Injection Braking/Setting Frequency")

- During a deceleration stop, DC injection braking is performed for the period set at the DC Injection Braking Time (F22/A11) from the time that the output frequency reaches or falls below the DC Injection Braking Start Frequency (F20/A09). However, if the Stop Frequency (F25) is higher than the DC Injection Braking Frequency (F20/A10), DC injection braking is started from the time the output frequency reaches the Stop Frequency (F25), and is performed for the period set at the DC Injection Braking Time (F22/A11).

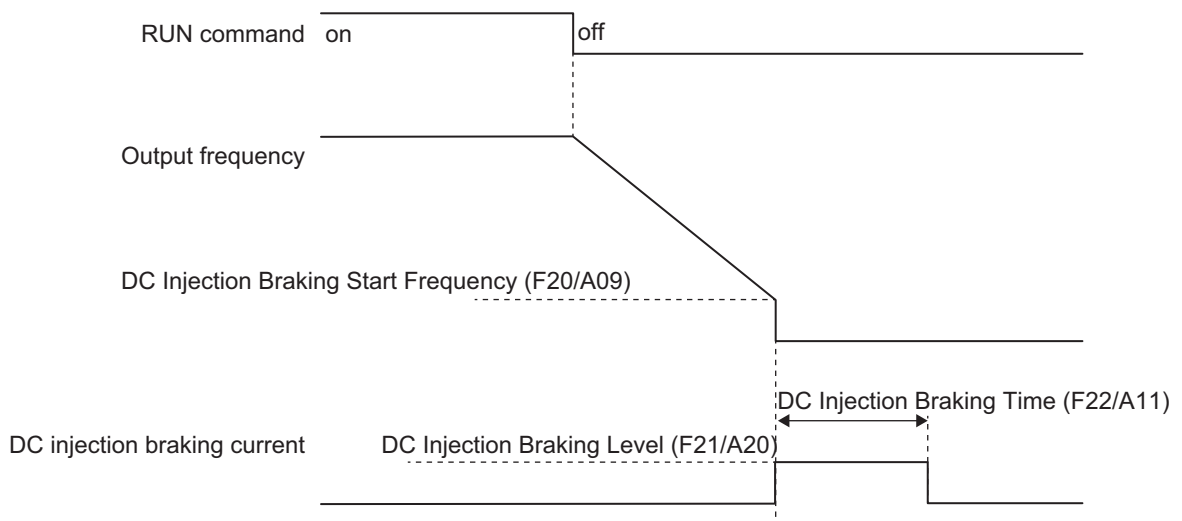

### DC Injection Braking Start at Frequency Reference and Output Frequency (E114 = "2: Setting Frequency")

- Use this method to control DC injection braking only by changing the set frequency (frequency reference). DC injection braking by DB terminal is disabled. The DC injection braking during startup by the settings of DC Injection Braking Startup Time (H195) is also disabled.
- DC injection braking is started for the period of the DC Injection Braking Time (F22/A11) from the time that both the frequency reference and the output frequency reach or fall below the DC Injection

Braking Start Frequency (F20/A09). However, if the Stop Frequency (F25) is higher than the DC Injection Braking Frequency (F20/A10), DC injection braking is started from the time the output frequency reaches the Stop Frequency (F25), and is performed for the period of the DC Injection Braking Time (F22/A11).

- If, during DC injection braking, the set frequency becomes higher than the DC Injection Braking Frequency (F20/A10) + 2 Hz, the Starting Frequency (F23/A12) or the maximum value set in the Stop Frequency (F25/A63), the inverter cancels DC injection braking and returns to normal operation. DC injection braking is also canceled when the RUN command is OFF.

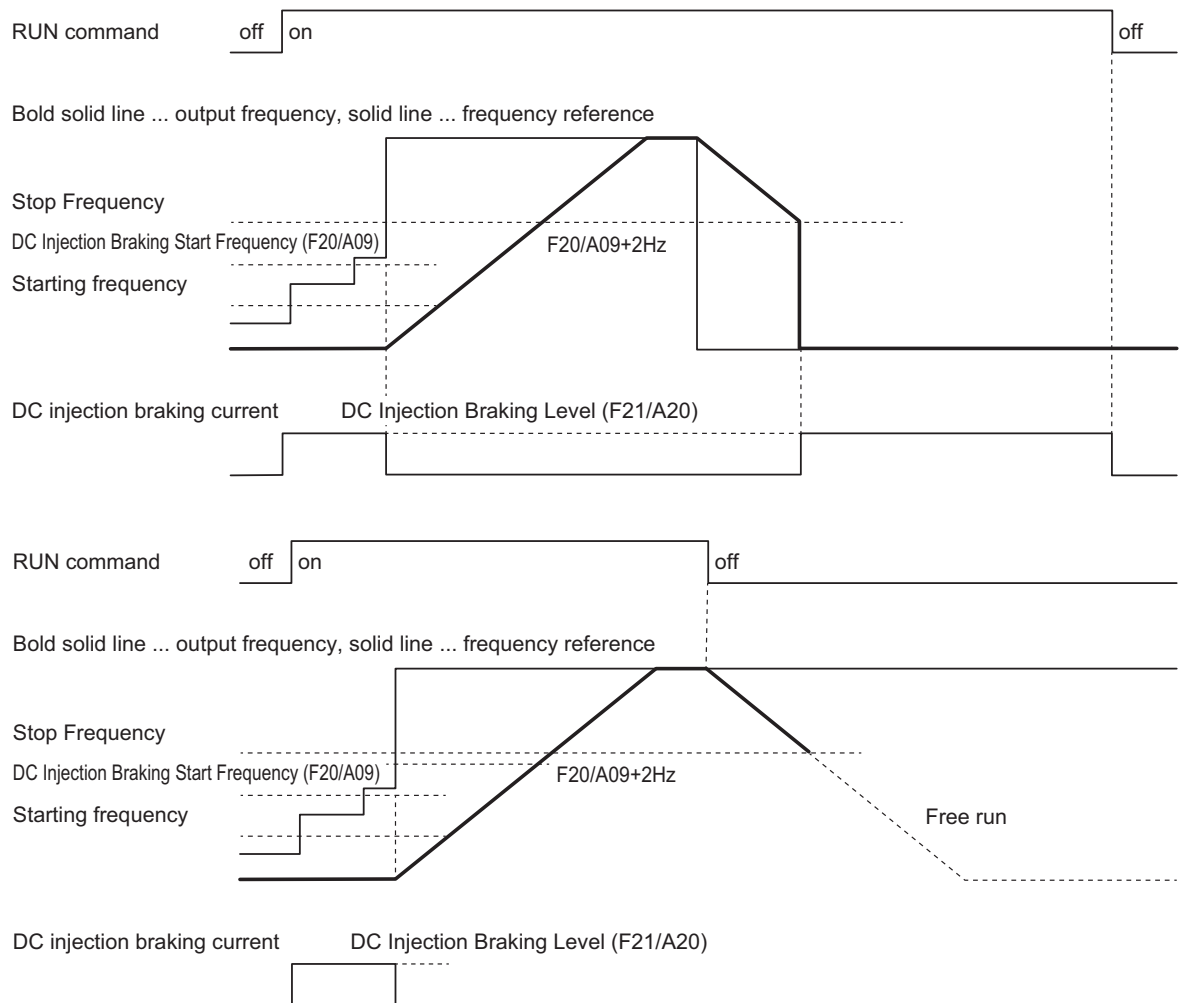

- When “0: Edge operation” is selected for External DC Injection Braking Edge/Level Selection (E115), DC injection braking operates for the period set at the DC Injection Braking Time (F22/A11) after the conditions to start DC injection braking are established.

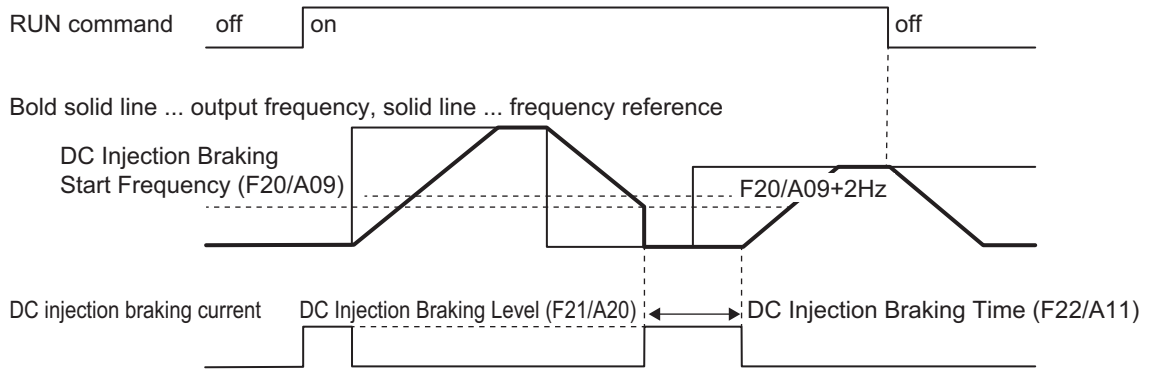

- When “1: Level operation” is selected for External DC Injection Braking Edge/Level Selection (E115), DC injection braking operates while the conditions to start DC injection braking are established.

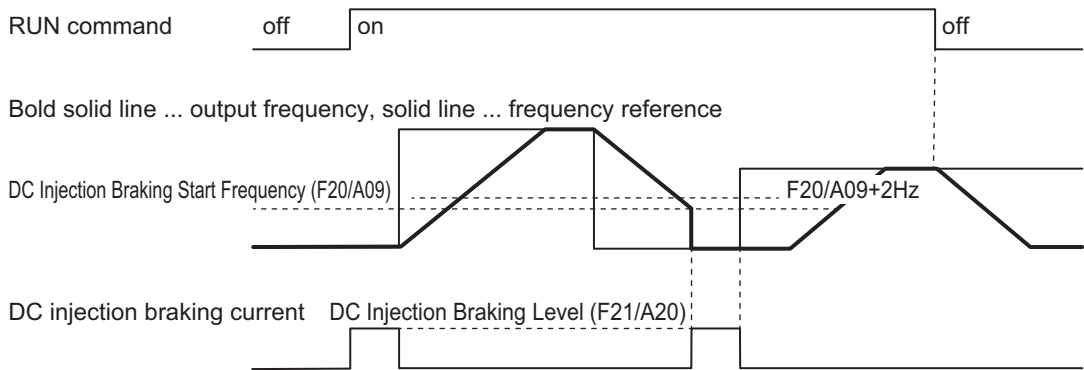

## DC Injection Braking Start Characteristic Selection (H95)

You can select the rise characteristics for DC braking.

H95 data	Characteristics
0	Slow response. The rise of the DC braking current is increased gently.
1	Quick response. The rise of the DC braking current is increased momentarily up to the braking level.

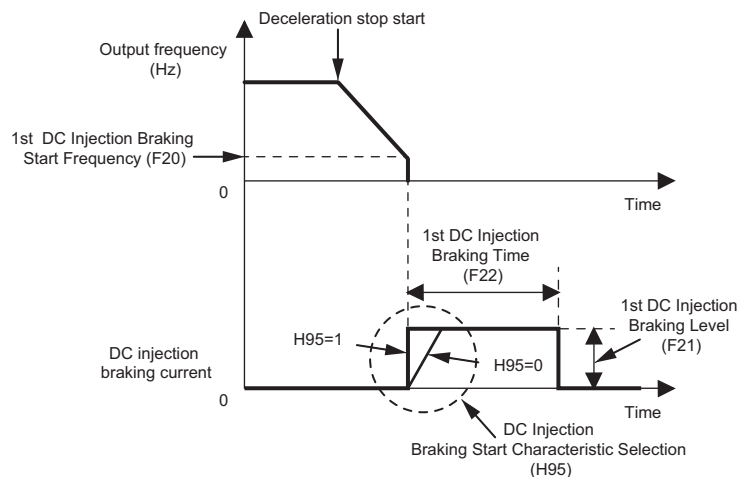



## 7-6 Safety Function

### 7-6-1 Overview of Safety Function

The safety function is designed so that the safety stop function of category 0 (uncontrolled stop) specified in IEC 60204-1 is used to meet the safety standards of PL-e under ISO 13849-1.

The safe torque OFF (STO) function cuts off the motor current and stops the motor by input signals from the safety controller.

When the STO function is activated, the servo driver turns servo ready output (READY) OFF to set the inverter to the safety state.

- STO Function by Safety Input Signal

### Safety Functions

Function	Standard
STO (Safe Torque Off)	EN/IEC 61800-5-2
Stop Category 0	EN/IEC 60204-1

### Response Time

Response time		Remarks
STO response time	50 ms or lower	Time from when the SF1/SF2 signal state changes to STO up to when power to the motor is cut off
EDM response time	50 ms	Time from when the SF1/SF2 signal state changes to STO up to when the EDM signal state changes to ON

### Safety Related Parameters

Parameter	Value	Standard
PL	e	EN/ISO 13849-1 EN/IEC 60204-1
Cat	3	
MTTFd	>62 years	
DCavg	Medium	

Parameter	Value	Standard
SIL	3	EN/IEC 61508-1 to -7
HFT	1	EN/IEC 61800-5-2
SFF	>90%	EN/IEC 62061
PFH	$3.00 \times 10^{-9}$	
PFD	$2.00 \times 10^{-5}$	
Mission time	20 years	

### 7-6-2 Safety Function Settings

Turn OFF the safety function selector switch SW9 when the inverter power supply is turned OFF.

Set SW9 to enabled (OFF) or disabled (ON) so that both sides are at the same position at all times.

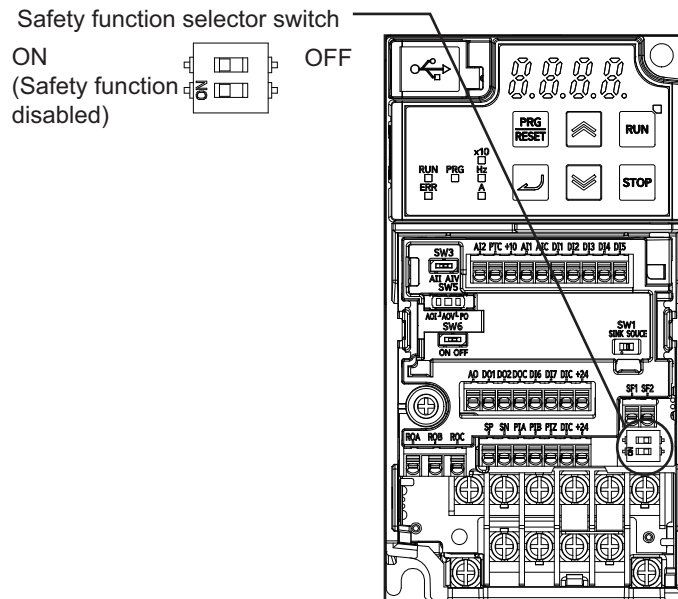

Turn both OFF to use the safety function.

Turn both ON to not use the safety function.

When only one is ON, the logic of the SF1 and SF2 signals no longer matches and this causes an EN circuit failure (alarm code: 39).

### 7-6-3 Wiring Safety Function for Use

The safety input function allows the inverter output when current flows in both the terminals [SF1] and [SF2]. When the safety input function is activated, in compliance with the safety standards described in *7-6-1 Overview of Safety Function* on page 7-69, the output transistor operation of the inverter is stopped safely (by shutting off its output). As a result, the motor stops with free run.

- It takes 50 ms or shorter from when the safety input is input till when the inverter shuts off the output.
- En is displayed on the data display.

Perform wiring with reference to the wiring example to meet the applicable safety standards. Be sure to use both the safety input [SF1] and [SF2] terminals and configure a system that turns OFF both of the [SF1] and [SF2] terminals when the safety function is activated.

If the inverter detects that either the [SF1] or [SF2] terminal is OFF, the safety function is activated and the inverter shuts off the output.

- The STO (Safe Torque Off) Performance Monitor (102: EDM) turns ON when the inverter detects that both of the [SF1] and [SF2] terminal signals turn OFF and shuts off the output. If the EDM output does not turn ON even when the inverter shuts off the output by the safety function, check the [SF1] and [SF2] terminal input circuits and the EDM detection circuit.
- The EN circuit failure detected (101: DECF) turns ON when an error occurs in the circuit that detects that the SF terminal is OFF.

Parameter No.	Function name	Data	Default data	Unit
E20, E21, E27	Output Terminal [DO1] Function Selection, Output Terminal [DO2] Function Selection, Output Terminal [ROA, ROB] Function Selection	101: DECF (EN circuit failure detected) 102: EDM (STO (Safe Torque Off) Performance Monitor)	-	-

## Wiring Example

Wiring example when EDM is enabled (for compliance with ISO13849-1 PL-e)

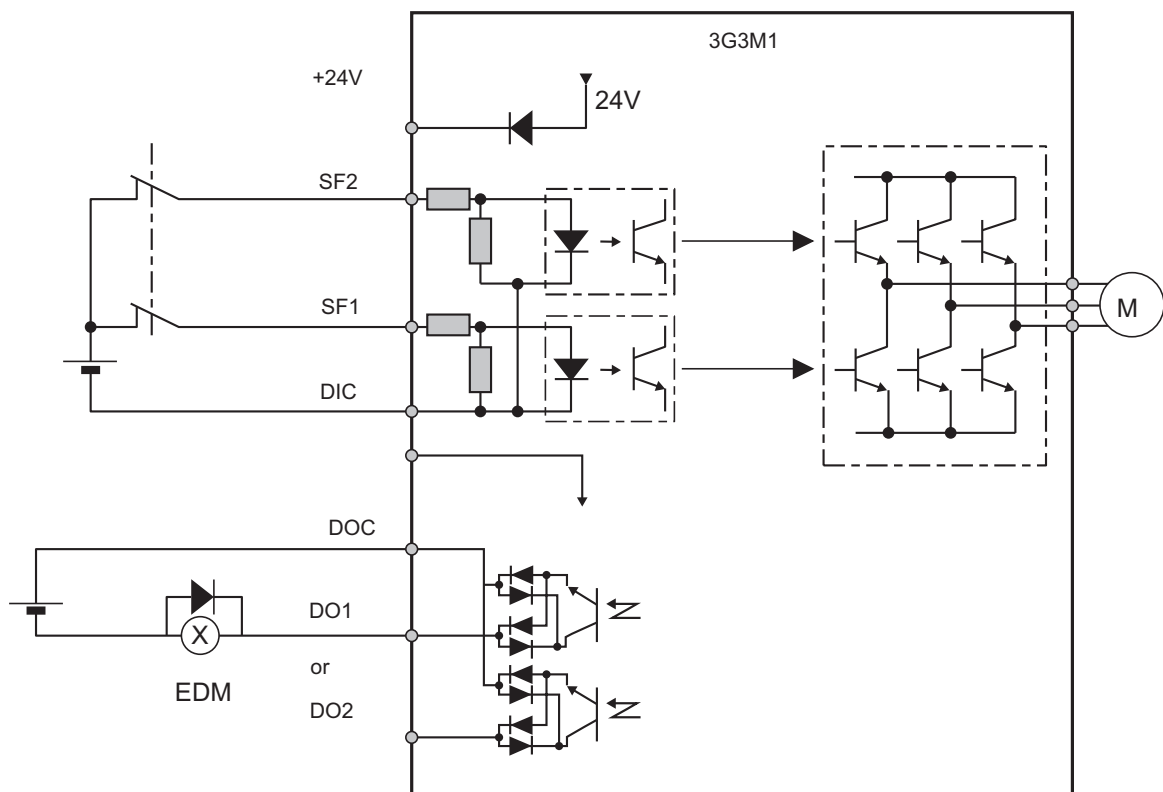

## System Configuration Example

To attain CAT.3, PLe/SIL3 as an overall system that uses the 3G3M1 Series, a PLe/SIL3 device must at least be combined into the system.

Test pulse that is input to safety input terminals [SF1] and [SF2] from an external device must be 1 ms or less.

The following shows an example of a safety interlock that is combined with the 3G3M1 Series.

Model	Applicable standard for system configuration	Certification authority
G9SP	EN ISO13849-1 PL-e Cat4 (IEC61508 SIL3)	TÜV Rheinland

## Periodic Inspection

The redundancy circuit is configured so that when the safety function is activated, the inverter shuts off its output if current no longer flows to either the safety input terminal [SF1] or [SF2]. Therefore, the inverter must be periodically inspected to ensure that there is no defect in the [SF1] and [SF2] terminal wirings so that redundancy is not lost to ensure reliable operation. Be sure to perform periodical inspection at least once in three months.

In periodic inspection, inspect the statuses shown in the table below.

Signal		Status 1	Status 2	Status 3	Status 4
Input	SF1	OFF	ON	OFF	ON
	SF2	OFF	OFF	ON	ON
Output	EDM	ON	OFF	OFF	OFF
	Output to motor	Shut off	Shut off	Shut off	Output enabled
Alarm		None	ECF	ECF	None

## Timing of transition to safety status

When one of safety input terminals [SF1] and [SF2] turns OFF and then both terminals turn OFF within 50 ms, control transitions to the STO state.

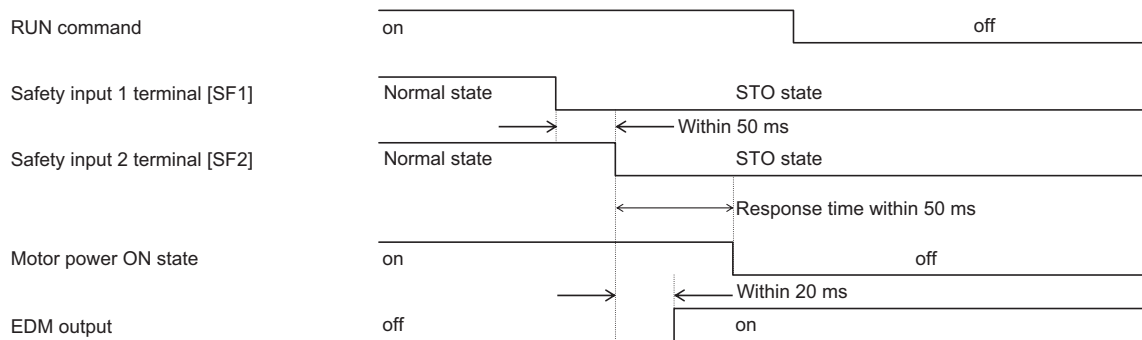

When one of terminals [SF1] and [SF2] turns OFF and then both terminals do not turn OFF within 50 ms, EN circuit failure (alarm code: ECF) is generated.

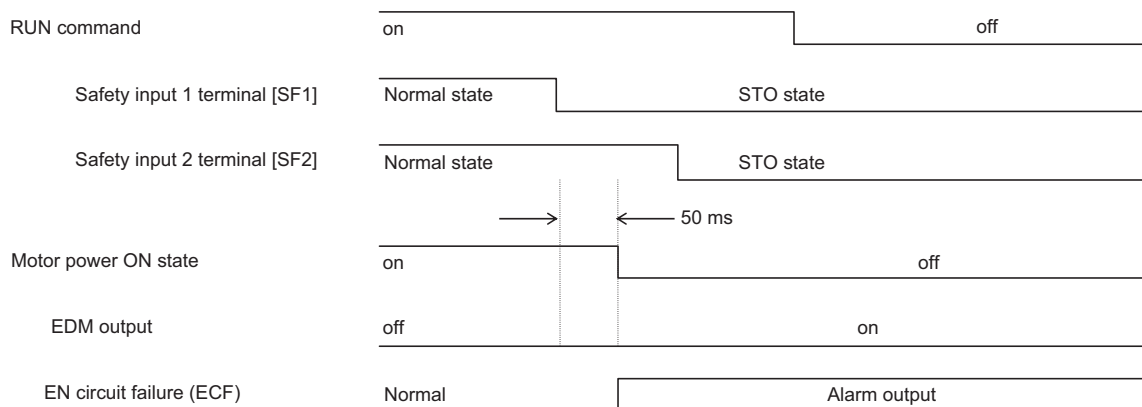

When terminals [SF1] and [SF2] are turned ON from an STO state, control returns from the STO state.

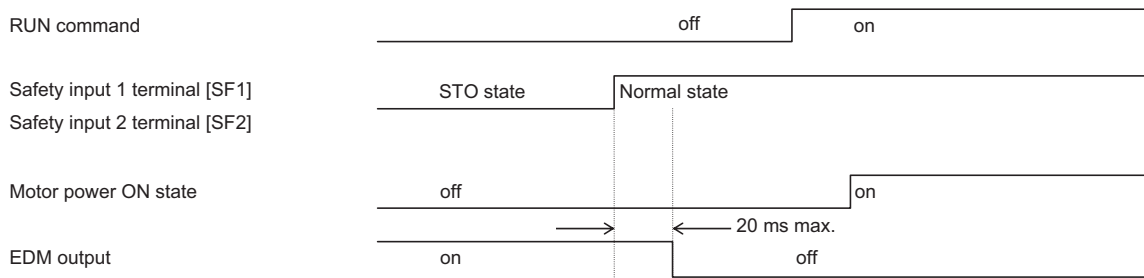

- To ensure that the safety function works normally, evaluate the entire safety system on every possible risk factor.
- The safety function is not intended to shut off the input or to isolate the output electrically. Be sure to shut off the input power supply to the inverter before attempting installation or maintenance.
- For the safety function, always use a cable length of 20 m or shorter.
- To restart the inverter after the safety function is activated, follow the steps below. Be sure to turn OFF the RUN command before you reset the safety equipment. Resetting the host safety equipment with the RUN command ON may cause the inverter to restart suddenly.
  1. Turn OFF the RUN command.
  2. Release the emergency stop switch.
  3. Reset the host safety equipment.
  4. After resetting the safety equipment, make sure that the inputs of the [SF1] and [SF2] terminals of the inverter are ON.
  5. Turn ON the RUN command to restart the inverter.
- Setting of the start check function is recommended to prevent sudden operation.
- It takes 50 ms or shorter from when the safety input is input till when the inverter shuts off the output.
- Install the inverter in a control panel with an enclosure rating of IP54 or higher.
- If minute pulses are to be input to the [SF1] and [SF2] terminals based on the diagnosis of the safety PLC, ensure that the pulse width is less than 1 ms.
- The logical mismatch between the [SF1] and [SF2] terminals based on the signal delay must be within 50 ms. If it exceeds 50 ms, an EN circuit failure (alarm code: ECF) is output.

## 7-7 Digital Operator and Operation Functions

This section describes the Digital Operator and other operation functions.

### 7-7-1 Soft Lock Function (SFT)

Use this function to protect various parameter settings against changes. This helps prevent data re-writing due to erroneous operation.

Allocate "19: SFT (Soft lock)" to input terminals [DI1] to [DI7] (E01 to E05, E98, E99).

Parameter No.	Function name	Data	Default data	Unit
F00	Operator Protection Function Selection	0 to 3 0: Disable parameter protection, enable Up/Down keys 1: Enable parameter protection, enable Up/Down keys 2: Disable parameter protection, disable Up/Down keys 3: Enable parameter protection, disable Up/Down keys	0	-
E01 to E05, E98, E99	Input Terminal [DI1] Function Selection to Input Terminal [DI7] Function Selection	19: SFT (Soft lock)	-	-

- Operation is performed as described below depending on the combination of Operator Protection Function Selection (F00) and SFT.
- Parameters via communication can be changed regardless of the setting of Operator Protection Function Selection (F00).

F00 data	SFT terminal ("19: SFT (Soft lock)")	Change of parameter data	Change of set frequency by Operator (increment key/decrement key) <sup>*2</sup>
0	ON or not allocated	Possible	Possible
1	ON or not allocated	Not possible <sup>*1</sup>	Possible
2	ON or not allocated	Possible	Not possible
3	ON or not allocated	Not possible <sup>*1</sup>	Not possible
-	OFF	Not possible	According to the setting of F00.

\*1. While parameters cannot be changed from the Digital Operator, parameter F00 can be changed.

\*2. Changing of the following that can be changed to Operator (increment key/decrement key) can be set to prohibited.

When "Operator (increment key/decrement key)" is selected at Frequency Reference (F01/C30), Frequency Calculation Operation Target 1 (E131), Frequency Calculation Operation Target 2 (E132) and PID Control PID Command Selection (J02).

- If changing of the parameter set values is prohibited by the soft lock function, they cannot be initialized from the Digital Operator. To execute initialization, first disable prohibition of changing the

parameter set value. For details on parameter initialization, refer to 5-1-2 *Data Initialization* on page 5-4.

## 7-7-2 Forced Operator Function (OPE)

If other than the Operator is selected for 1st Frequency Reference Selection (F01)/2nd Frequency Reference Selection (C30) and 1st RUN Command Selection (F02)/2nd RUN Command Selection (E102), use this function to forcibly enable the operations from the Operator by turning the multifunction input terminal ON/OFF.

When “35: OPE (Forced operator)” is allocated to the multifunction input terminal and turn the OPE terminal ON, it results in forcible frequency reference and RUN command from the Digital Operator. At this time, if F02 is 0, 2, 3, the operation direction follows F02. In other cases, the operation direction is forward.

If “54: RMT (Under remote mode)” is allocated to the output terminal, the signal turns ON when the forced operator function is disabled and turns OFF when it is activated.

If input is performed simultaneously with the forced terminal block (162: F-TM), the forced operation function is given priority. Moreover, the forced operation function is given priority in the case of frequency reference than the multi-step speed reference.

Parameter No.	Function name	Data	Default data	Unit
E01 to E05, E98, E99	Input Terminal [DI1] to [DI7] Function Selection	35: OPE (Forced operator)	-	-
E20, E21, E27	Output Terminal [DO1] Function Selection, Output Terminal [DO2] Function Selection, Output Terminal [ROA, ROB] Function Selection	54: RMT (Under remote mode)	-	-
Related function		F01, C30, F02, E102		

## 7-7-3 Forced Terminal Block Function (F-TM)

If other than the control circuit terminal block is selected for 1st Frequency Reference Selection (F01)/2nd Frequency Reference Selection (C30) and 1st RUN Command Selection (F02)/2nd RUN Command Selection (E102), use this function to forcibly enable the operations from the control circuit terminal block by turning the input terminal ON/OFF.

If “162: F-TM (Forced terminal block)” is allocated to Input Terminal [DI1] Function Selection to Input Terminal [DI7] Function Selection (E01 to E05, E98, E99), the operation is performed from the frequency reference source and RUN command source selected by 1st Frequency Reference Selection (F01)/2nd Frequency Reference Selection (C30) and 1st RUN Command Selection (F02)/2nd RUN Command Selection (E102) if the F-TM terminal has been canceled, and the operation is performed forcibly by the frequency reference and the RUN command from the control circuit terminal block if there is an input.

If the forced terminal block function is enabled during operation, the RUN command is canceled and the inverter output stops.

If input is performed simultaneously with the OPE terminal (35: Forced operator), the forced operator is given priority.

The frequency reference for the forced terminal block function is the frequency reference based on the input terminals [AI1] + [AI1](All).

The RUN command for the forced terminal block function is the FW terminal and the RV terminal allocated to the input terminal. If the FW terminal and RV terminal are not allocated to the input terminal, it becomes impossible to perform operation.

The forced terminal block function is given priority in the case of frequency reference than the multi-step speed reference.

When the start check function is set to enabled, the start check function is executed when the F-TM terminal (162: Forced terminal block) is turned ON. (For details on the start check function, refer to 7-7-7 STOP Key Priority/Start Check Function on page 7-80.)

Parameter No.	Function name	Data	Default data	Unit
E01 to E05, E98, E99	Input Terminal [DI1] to [DI7] Function Selection	162: F-TM (Forced terminal block)	-	-
Related function		F01, C30, F02, E102		

## 7-7-4 Initial Screen Selection

### LED Monitor (Item Selection)

This function makes it possible to select the monitor information of the operation status displayed on the Operator LED.

If speed monitor is selected at Operator Display Selection during Run (E43), the display is in the speed form selected at Operator Display Speed Monitor Item Selection (E48).

If the Operator is not operated for five minutes, the display automatically changes to the initial screen selected at Operator Display Selection during Run (E43).

For details on Operator Display Selection during Run (E43) and Operator Display Speed Monitor Item Selection (E48), refer to 3-1-2 Key Operation Method on page 3-3.

Parameter No.	Function name	Data	Default data	Unit
E43	Operator Display Selection during Run	Refer to 3-1-2 Key Operation Method on page 3-3.	0	-
E48	Operator Display Speed Monitor Item Selection		0	-

### LED Monitor (Display when Stopped)

Select the monitor information to be displayed on the Operator when the inverter is stopped. The set frequency is displayed in the case of Operator Display when Stopped Selection (E44) = 0 and the output frequency is displayed in the case of Operator Display when Stopped Selection (E44) = 1. The display format is that selected at Operator Display Speed Monitor Item Selection (E48).



Parameter No.	Function name	Data	Default data	Unit
E44	Operator Display when Stopped Selection	0: Specified value 1: Output value	0	-

E48 data	Monitor selection	E44 = 0: Specified value	E44 = 1: Output value
0	Output frequency 1 (before slip compensation)	Set frequency	Output frequency 1 (before slip compensation)
1	Output frequency 2 (after slip compensation)	Set frequency	Output frequency 2 (before slip compensation)
2	Set frequency	Set frequency	Set frequency
3	Motor rotation speed	Motor speed set value	Rotation speed
4	Load Shaft Speed	Load shaft speed set value	Load shaft speed
5	Line speed	Line speed set value	Line speed
6	Transport time for specified length	Transport time set value for specified length	Transport time for specified length
7	Speed (%)	Speed set value	Speed

## 7-7-5 Password Function

This is a function for completely or partially obscuring the parameters set in the inverter. The set values of all parameters can be protected by two types of passwords as rewriting prohibited. While password 1 enables the selection of the protection operation, password 2 disables the disclosure and changing of all parameters.

Pay sufficient attention to the use of password as once a password is set, it cannot be changed or deleted.

Parameter No.	Function name	Data	Default data	Unit
H197	User password 1 Mode selection	0: All parameters cannot be changed 1: Those other than favorite parameters cannot be displayed or changed	0	-
H198	User Password 1 Setting/Verification	0000 to FFFF Hex	0000	-
H99	Password 2 Setting/Verification	0000 to FFFF Hex	0000	-
H199	User Password 1 Setting	0: Disable 1: Protected	0	-

## Password Protection

By setting a password (four digit in hexadecimal) at User Password 1 Setting/Verification (H198) and setting 1 at User Password 1 Setting (H199), the parameter is protected by password 1 (protection against rewriting).

Select the parameters targeted for protection at User password 1 Mode selection (H197).

- When "0" is set to User password 1 Mode selection (H197), the values of all parameters cannot be rewritten.
- When "1" is set to User password 1 Mode selection (H197), parameters other than those registered as favorite parameters cannot be read or written.

With password 2, the set value of all parameters can be protected against reading and rewriting regardless of the selection in User password 1 Mode selection (H197).

The following parameters are not protected by passwords 1 and 2.

◆ Operator displays

E39/A61: Display Coefficient 1 for Transport Time / Auxiliary Display Coefficient 1 for Speed Monitor/2nd Display Coefficient for Transport time / Auxiliary Display Coefficient for Speed Monitor

E42: Operator Display Filter

E43: Operator Display Selection during Run

E44: Operator Display when Stopped Selection

E48: Operator Display Speed Monitor Item Selection

E50/A60: 1st Frequency Conversion Coefficient and 2nd Speed Conversion Coefficient

E52: Operator Display Selection

◆ Frequency references

C99/E109: 1st Frequency Reference/1st Multi-step Frequency Reference 0/2nd Frequency Reference/2nd Multi-step Frequency Reference 0

◆ Communication commands and communication monitors

Parameter group S, M, W, X, Z

By setting a password at Password 2 Setting/Verification (H99) and setting 1 to User Password 1 Setting (H199), the parameter is protected by password 2 (protection against reading or writing).

As for parameters for which reading or writing is prohibited, it is not possible to write set values to the inverter by an external equipment using the Digital Operator or serial communication, and also to read the set values.

If a parameter is protected by password 1 and the password set to User Password 1 Setting/Verification (H198) is entered again, the protected state is canceled. If password 2 is also set simultaneously, password 2 must be canceled beforehand at Password 2 Setting/Verification (H99).

If the value of the password entered to User Password 1 Setting/Verification (H198) or User Password 2 Setting/Verification (H99) to cancel the protection status is wrong, the protection status cannot be temporarily canceled, and, when five retries to enter the password are continuously wrong, a password cancellation error (Lok) is generated.

In the password cancellation error (Lok) status, User Password 1 Setting/Verification (H198)/User Password 2 Setting/Verification (H99) cannot be entered. (The inverter can be operated)

To cancel the password cancellation error, either turn the inverter power supply OFF then back ON again, or wait for 20 minutes.

The password protection status can be checked by the lighting status (out, lit or flashing) of the least significant digit dot on the data display.

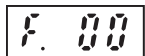
Password protection status	Least significant digit dot display	
	Description	Example
Password not set	OFF	

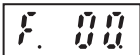
Password protection status	Least significant digit dot display	
	Description	Example
Password cancellation in progress	Low-speed flashing (1 s cycle)	
Protected by password 1	Lit	
Protected by password 2		
Lok minor alarm/alarm occurring		

## Enabling/Disabling Conditions

The password is enabled when a value other than 0 is set to User Password 1 Setting/Verification (H198) and Password 2 Setting/Verification (H99).

From the viewpoint of ensuring security, to make sure that only the person who sets the password can change or delete it, a password cannot be disabled (password deletion) once it has been enabled. Moreover, a password cannot be changed.

However, the password is deleted by initializing the inverter itself, and password protection is disabled.

## How To Use the Password Function

Perform the following operations to use the password function.

### <Setting a password from a password not set status>

When a hexadecimal 4-digit password is entered to one or both of User Password 1 Setting/Verification (H198) and Password 2 Setting/Verification (H99), the password is set and it is in protection cancellation state.

To use user password 1, select the target to be protected at User password 1 Mode selection (H197). Note that once a password is set, it cannot be changed or deleted.

### <Changing the protection cancellation state to the protected state>

The status of a password changes to the protection state by setting 1 at User Password 1 Setting (H199). The state also changes to the protection status after turning the inverter back ON again or after four hours have elapsed since the state was set to the protection cancellation state.

When user password 1 is set, the status of the target to be protected that is set at User password 1 Mode selection (H197) is rewriting prohibited.

When user password 2 is set, the status of all parameters is reading/writing prohibited.

When both two user passwords are set, priority is given to user password alarm code: 2.

### <Canceling the protection status (when only one of the user passwords is set)>

The password protection status can be canceled by entering the password from the protection status. When only one of user password 1 or user password 2 is set, the status of all protection is canceled by entering the set password.

### <Canceling the protection status (when both two user passwords are set)>

When both two user passwords are set, begin entry with user password 2.

When user password 2 is canceled, the status changes to user password 1 protection status, and the status of the target to be protected selected at User password 1 Mode selection (H197) changes to

protected. When user password 1 is canceled in this status, this means that all passwords will have been canceled.

## Cautions Regarding the Password Function

- 0000 cannot be set to passwords.
- Once a password is set, it cannot be changed or deleted.
- There is no way of checking a password once it is set. When you have forgotten a password, its protection status cannot be canceled. So, the inverter itself must be initialized. To perform initialization while in the protection status, this will be executed on condition that the inverter will be in the password cancellation error (alarm code: Lok) status. Enter a wrong password five times to set the invert to the password cancellation error (alarm code: Lok) status, and then perform initialization by Data Initialization (H03). At this time, only “1: Initialize all parameters” can be selected at Data Initialization (H03).

### 7-7-6 User Parameter Setting Function

If the  key is pressed and held during the display of a parameter, the parameter is registered in “user preferences,” and to indicate that the parameter has been registered, the decimal LED of the uppermost digit lights up. If the same operation is performed one more time, the parameter is removed from “user preferences,” and the decimal LED of the uppermost digit turns OFF.

If menu number 0 “User preferences: 0.Fnc” is selected in the program mode, the parameters registered in user preferences are displayed. There is no limit to the number of parameters that can be registered.

### 7-7-7 STOP Key Priority/Start Check Function

Combinations of the STOP key priority and start check functions can be selected.

Parameter No.	Function name	Data	Default data	Unit
H96	STOP Key Priority/ Start Check Function	0 to 3 0: Disable STOP key priority, disable start check function 1: Enable STOP key priority, disable start check function 2: Disable STOP key priority, enable start check function 3: Enable STOP key priority, enable start check function	0	-
Related function	Stop Selection (H11) Deceleration time (F07, E10, F08, E11)			



## STOP Key Priority (When (H96) = “1”, “3”)

- When STOP key priority is selected, a stop operation is performed according to Stop Selection (H11) by the  key on the Operator, and a run operation error (Er6: sub code 1) is displayed on the

LED monitor. For details on the alarm code/sub code display, refer to 9-1-1 *Alarm Display* on page 9-2.

## Start Check Function (When (H96) = “2,” “4”)

- The start check function checks the status of the RUN command at the following check timing and generates an error.
- When a RUN command is input, the inverter is not operated and a run operation error (Er6: sub codes 2 to 6) is generated. (For details on RUN command, refer to 5-4-1 *RUN Command Selection* on page 5-25.)
- The content of sub codes 2 to 6 and the check timing are as follows.

Er6 alarm sub code	Alarm sub code contents	Check timing
2	Start check function	When switching is performed on the SET terminal (12: Set 2nd control), OPE terminal (25: Forced operator) or F-TM terminal (162: Forced terminal block)
3	Start check function (when operation is permitted)	When “ROK” (Permission of Run command) is turned ON while the RUN command is ON
4	Start check function (at a reset power ON)	When the  key is pressed or the RS terminal (8: Reset) is turned ON while an alarm is generated
5	Start check function (at power restoration when power is turned ON)	When the power is turned ON
6	Start check function (Operator connection)	When the Operator is mounted with the  key pressed

- The check function is enabled even in the following status in which the RUN command is input and the RUN command is disabled.
  - FRS terminal (7: Free-run stop) ON and RUN command ON
  - ROK terminal (38: Permission of Run command) OFF and RUN command ON
  - STO terminal status (EN terminal OFF) and RUN command ON
  - FW terminal (98: Forward Run/Stop) ON and RV terminal (99: Reverse Run/Stop) ON

## 7-8 Functions Related to Protection, Warning and Various Output Signals

This section describes the protection functions such as warning signals.

### 7-8-1 Current Limit/Overload Prevention Control/Overload Warning

#### Current limit

If the output current of the inverter becomes equal to or above the current limitation level, the output frequency is controlled to prevent the engine from stalling.

- It is enabled when “0: IM V/f control,” “1: IM Dynamic torque vector control without speed sensor,” “3: IM V/f control with speed sensor” or “4: IM Dynamic torque vector control with speed sensor” is selected for Drive Control Selection (F42/A14).

Select the operation of this function at 1st Overload Protect Function Selection (F43)/2nd Overload Protect Function Selection (E146).

At 1st Overload Protect Level (F44)/2nd Overload Protect Level (E147), set an operation level with the inverter rated output current value as 100%.

If this function is operated while the inverter is accelerating, the acceleration time becomes longer than the set time.

The lower limit value of the frequency when the current limitation is operated can be set at Low Frequency during Protecting Overload (H64), but generally, there is no need to change the settings. Besides current limitation, Low Frequency during Protecting Overload (H64) is also applicable to torque limitation and overload prevention control.

Parameter No.	Function name	Data	Default data	Unit
F43/E146	1st Overload Protect Function Selection/2nd Overload Protect Function Selection	0: Disable 1: Enable at constant speed (Disable during ACC/DEC) 2: Enable during ACC/constant speed operation	2	-
F44/E147	1st Overload Protect Level/2nd Overload Protect Level	20 to 200% 100% = Rated output current of inverter (Default: 180% for HHD mode and 130% for ND mode)	180	%
H64	Low Frequency during Protecting Overload	0.0: Depends on 1st Frequency Lower Limit (F16) and 2nd Frequency Lower Limit (E118) 0.1 to 590.0 Hz	1.6	Hz

Example case where overload limit function is activated during acceleration (F43/E146 = 2)

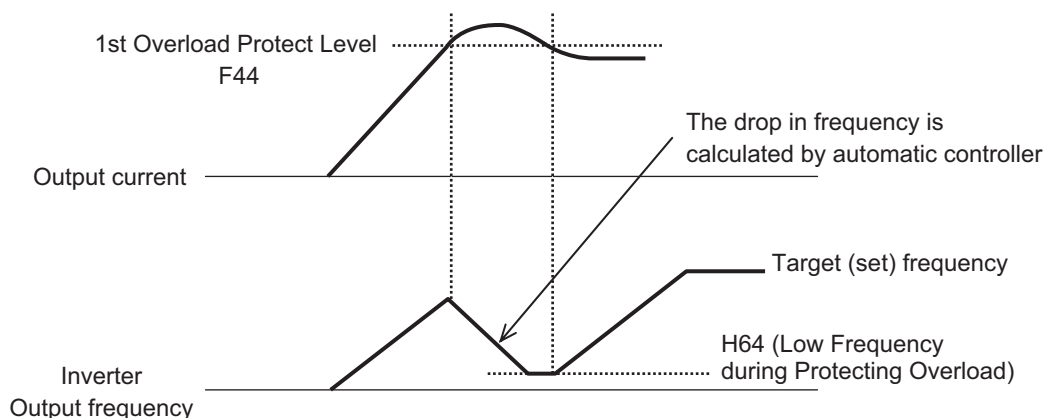

## Overload Prevention Control

Set the rate of decline of the output frequency of overload prevention control. This function causes the inverter output frequency to drop before the cooling fin of the inverter overheats (alarm code: 0H1) or an overload trip occurs (alarm code: 0LU), and thus prevents tripping. This function is applicable in equipment such as pumps where the load reduces with a drop in the output frequency, but it is necessary to continue with the operation even when the output frequency drops.

Allocating “36: OLP (Overload prevention controlling)” to Output Terminal [DO1] Function Selection, Output Terminal [DO2] Function Selection and Output Terminal [ROA, ROB] Function Selection activates overload prevention control and indicates that the output frequency changes, and the signal “OLP” that turns ON during the overload prevention control is output.

Parameter No.	Function name	Data	Default data	Unit
H70	Overload Prevention Control	0.00: Depend on selected deceleration time <sup>*1</sup> 0.01 to 100.00 Hz/s 999: Cancel	999	Hz/s
E20, E21, E27	Output Terminal [DO1] Function Selection, Output Terminal [DO2] Function Selection, Output Terminal [ROA, ROB] Function Selection	36: OLP (Overload prevention controlling)	-	-
Related function	Output Terminal [DO1] ON Delay Time (H309), Output Terminal [DO2] ON Delay Time (H311), Output Terminal [ROA, ROB] ON Delay Time (H313), Output Terminal [DO1] OFF Delay Time (H310), Output Terminal [DO2] OFF Delay Time (H312), Output Terminal [ROA, ROB] OFF Delay Time (H314)		-	-

\*1. Deceleration is performed according to the currently selected deceleration time by the SET, RT1 and RT2 terminals.

\*2. The OFF delay becomes the time obtained by adding 0.1 s to Output Terminal [DO1] OFF Delay Time (H310), Output Terminal [DO2] OFF Delay Time (H312) and Output Terminal [ROA, ROB] OFF Delay Time (H314).

## Overload Warning

The overload warning function causes the inverter to output an overload warning if the load is too large, before it detects an overload trip.

- This is useful to prevent mechanical damage to transfer machines, etc. due to overweighed loading, or stoppage of transfer lines due to an overload, through the use of the overload protection function of the inverter.
- To output this signal, allocate “38: OL (Overload warning)” or “37: OL2 (Overload warning 2)” to Output Terminal [DO1] Function Selection (E20), Output Terminal [DO2] Function Selection (E21) and Output Terminal [ROA, ROB] Function Selection (E27). (Two types of overload warning signals can be output.)
- When using “38: OL (Overload warning),” set the overload warning detection level and overload warning detection timer for each of 1st and 2nd control. When using “37: OL2 (Overload warning 2),” set Overload early warning 2 Level (OL2) (E34) and Overload early warning 2 Detection Timer (OL2) (E35) regardless of 1st and 2nd control.

Parameter No.	Function name	Data	Default data	Unit
<b>Common setting for OL and OL2</b>				
E185	Overload Warning Detection Condition Selection (OL1, OL2)	0 to 1 0: Output during acceleration/ deceleration and constant-speed operation 1: Output only during constant-speed operation	1	-
<b>Overload warning OL (Set the detection level and detection timer for each of 1st and 2nd control)</b>				
E37	1st Overload Early Warning Detection Level	0.00; 0.01 to 3000 0.00: Disable 0.01 to 3000 A, setting range from 1% to 200% of the rated inverter current.	21.00	A
E38	1st Overload Early Warning Detection Timer / Low Current detection level (OL, LOC)	0.01 to 600.00	10.00	s
E55	2nd Overload Warning Detection Level* <sup>1</sup>	0.00; 0.01 to 3000 0.00: Disable 0.01 to 3000 A, setting range from 1% to 200% of the rated inverter current.	21.00	A
E56	2nd Overload Early Warning Detection Timer* <sup>1</sup>	0.01 to 600.00	10.00	s
E20, E21, E27	Output Terminal [DO1] Function Selection, Output Terminal [DO2] Function Selection, Output Terminal [ROA, ROB] Function Selection	38: OL (Overload warning)	-	-
<b>Overload warning OL2 (common to 1st and 2nd control)</b>				
E34	Overload early warning 2 Level (OL2)	0.00; 0.01 to 3000 0.00: Disable 0.01 to 3000 A	21.00	A



Parameter No.	Function name	Data	Default data	Unit
E35	Overload early warning 2 Detection Timer (OL2)	0.01 to 600.00	10.00	s
E20, E21, E27	Output Terminal [DO1] Function Selection, Output Terminal [DO2] Function Selection, Output Terminal [ROA, ROB] Function Selection	37: OL2 (Overload warning 2)	-	-
Related function		Output Terminal [DO1] ON Delay Time (H309), Output Terminal [DO2] ON Delay Time (H311), Output Terminal [ROA, ROB] ON Delay Time (H313), Output Terminal [DO1] OFF Delay Time (H310), Output Terminal [DO2] OFF Delay Time (H312), Output Terminal [ROA, ROB] OFF Delay Time (H314)	-	-

- \*1. To enable switching to the 1st and 2nd control, allocate "12: SET (Set 2nd control)" to either of input terminal [DI1] to [DI7].
- \*2. The OFF delay becomes the time obtained by adding 0.1 s to Output Terminal [DO1] OFF Delay Time (H310), Output Terminal [DO2] OFF Delay Time (H312) and Output Terminal [ROA, ROB] OFF Delay Time (H314).
- Overload warning has a hysteresis characteristic of operation level  $\times 10\%$ . The minimum output signal width of the signal is 100 ms.

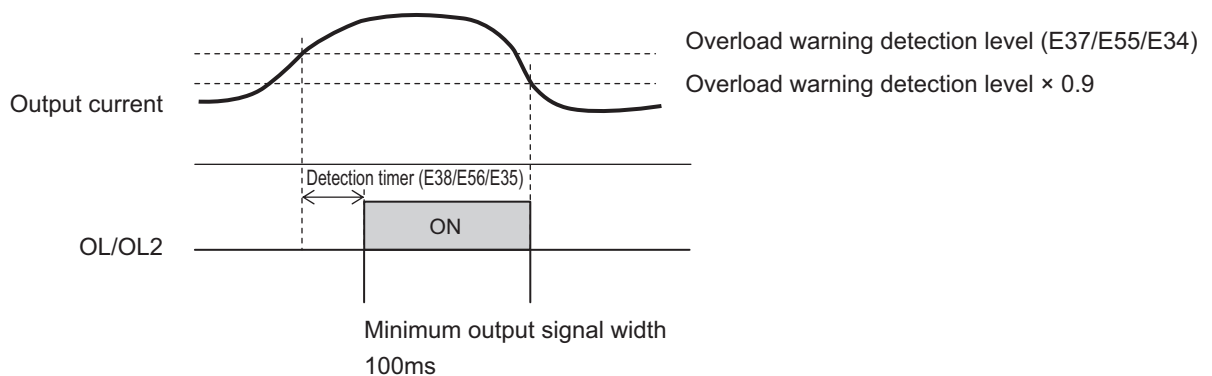

## 7-8-2 Anti-regenerative Control Function

- This function controls the output frequency to suppress regenerative energy and avoid overvoltage tripping.
- The action of this function can be selected at Anti-regenerative Control Function Selection (H69).
- This function is temporarily disabled when "82: AR-CCL" is set at Input Terminal [DI1] Function Selection to Input Terminal [DI7] Function Selection and the AR-CCL terminal is turned ON.

Parameter No.	Function name	Data	Default data	Unit
H69	Anti-regenerative Control Function Selection	0: Disable 2: Torque limit control with forced stop after three times deceleration time has passed 3: Main Circuit DC Voltage control with forced stop after three times deceleration time has passed 4: Torque limit control without forced stop 5: Main Circuit DC Voltage control without force-to-stop	0	-
H114	Anti-regenerative Control Level	0.0 to 50.0 999: Standard control level	999	%
H76	Frequency Rising Limit for Torque Limit	0.0 to 590.0 Hz	5.0	Hz
Related functions		E01 to E05, E98, E99		

- Anti-regenerative control sometimes increases the deceleration time.
- When the braking unit is connected, do not use anti-regenerative control. Anti-regenerative control sometimes acts simultaneously with operation of the braking unit and the deceleration time is not as set.
- When the deceleration time is too short, the Main Circuit DC Voltage of the inverter sometimes rises quickly and anti-regenerative control cannot keep up. In instances like this, set a longer deceleration time.

## Torque Limit (H69 = 2, 4)

- A feature is that response is high and an overvoltage trip is less likely to occur even by an impact load. The frequency control value can be adjusted by Anti-regenerative Control Level (H114), and, when the Anti-regenerative Control Level (H114) is increased, frequency control increases.
- This is enabled during acceleration, constant speed and deceleration.
- The output frequency is controlled until braking torque reaches almost 0 (zero).
- Although Anti-regenerative Control Level (H114) can be adjusted, normally adjustment is not required.
- When the output frequency is limited, an overvoltage trip sometimes is generated as anti-regenerative control is limited. Anti-regenerative capability can be improved by setting a larger Frequency Rising Limit for Torque Limit (H76).

## Main Circuit DC Voltage Control (H69 = 3, 5)

- This is enabled only at deceleration.
- When the main circuit intermediate voltage exceeds limitation level, the output frequency is controlled so that the main circuit intermediate voltage is lowered.
- The regeneration capacity of an inverter can be made use of to shorten the deceleration time.
- When “Main Circuit DC Voltage control with forced stop after three times deceleration time has passed” has been set, anti-regenerative control is suspended and the motor is stopped according to the selected deceleration time when a time three times of the currently selected deceleration time

elapses after the RUN command is turned OFF. Use this function when the load state causes the output frequency to rise by anti-regenerative control and the motor does not stop.

### 7-8-3 Instantaneous Overcurrent Limitation

- This function is used to select whether to perform the current limitation process (a process where the inverter output is momentarily turned OFF to suppress an increase in the current, and the output frequency is operated) or overcurrent tripping when the output current of the inverter becomes equal to or above the instantaneous overcurrent limitation level.
- If the torque generated by the motor is temporarily reduced due to the current limitation process, and a failure occurs for the use of the equipment or machinery, it is necessary to perform overcurrent tripping and use a mechanical brake.
- During instantaneous current limitation operation, Inverter output limiting signal (05: IOL), (22: IOL2) is output.

Parameter No.	Function name	Data	Default data	Unit
H12	Instantaneous Overcurrent Limiting Function Selection	0: Disable (Overcurrent tripping at an instantaneous overcurrent limitation level) 1: Enable (Instantaneous current limitation operation is enabled)	1	-
E20, E21, E27	Output Terminal [DO1] Function Selection, Output Terminal [DO2] Function Selection, Output Terminal [ROA, ROB] Function Selection	5: IOL (Inverter output limiting) 22: IOL2 (Inverter output limiting with delay)	-	-

### 7-8-4 External Trip (EXT)

Use this signal to have the inverter trip via an error signal generated by a peripheral system. To do so, allocate "9: EXT (External trip)" to Input Terminal [DI1] Function Selection to Input Terminal [DI7] Function Selection (E01 to E05, E98, E99).

When the EXT terminal turns ON, the inverter trips with the alarm code 0H2 displayed and shuts off its output.

Once the inverter trips and generates the external alarm (alarm code: 0H2), the trip status will not be reset even if the error signal from external equipment is reset (the EXT terminal is turned ON).

In this case, perform the reset operation or cycle the power supply to reset the trip. For details on a reset operation, refer to 5-8 Reset on page 5-49.

Parameter No.	Function name	Data	Default data	Unit
E01 to E05, E98, E99	Input Terminal [DI1] to [DI7] Function Selection	9: EXT (External trip)	-	-

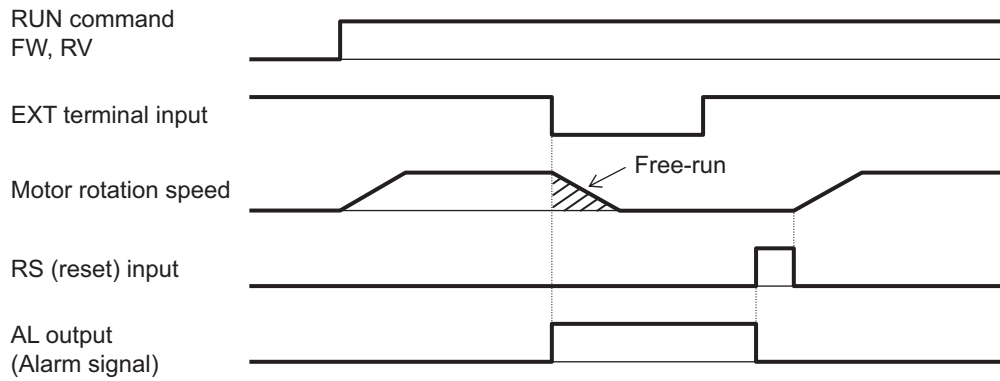

If the RUN command is being input when the alarm is cleared by a reset after a trip, operation is started in accordance with the frequency reference. To prevent operation from being started unintentionally, set the start check function to enabled. For details on the start check function, refer to *Start Check Function (When (H96) = "2," "4")* on page 7-81.

### 7-8-5 Thermistor Trip Function

You can provide thermal protection for external equipment such as a motor by connecting a thermistor installed on it to the inverter and enabling this function.

Parameter No.	Function name	Data	Default data	Unit
H26	Thermistor Function Selection (MOH)	0: Disable 1: Inverter immediately trips with OH4 displayed 2: Inverter issues output signal MOH and continues to run	0	-
H27	1st Thermistor Error Detection Level (MOH)	0.00 to 5.00	1.60	V
E20, E21, E27	Output Terminal [DO1] Function Selection, Output Terminal [DO2] Function Selection, Output Terminal [ROA, ROB] Function Selection	56: MOH (Motor overheat detected by thermistor)	-	-
Related function		Output Terminal [DO1] ON Delay Time (H309) Output Terminal [DO2] ON Delay Time (H311) Output Terminal [ROA, ROB] ON Delay Time (H313) Output Terminal [DO1] OFF Delay Time (H310) Output Terminal [DO2] OFF Delay Time (H312) Output Terminal [ROA, ROB] OFF Delay Time (H314)		

Connect a PTC thermistor between the [PTC] terminal and the [AIC] terminal. If, as a result of the resistance value of the connected PTC thermistor, the internal power supply is divided, and the voltage between the [PTC] terminal and the [AIC] terminal exceeds 1st Thermistor Error Detection Level (MOH) (H27), operation set at Thermistor Function Selection (MOH) (H26) is performed. Take thermistor error into consideration when setting the 1st Thermistor Error Detection Level (MOH) (H27). If the resistance value of a PTC thermistor at the protection temperature is considered as  $R_p$ , the operation level  $V_{OH}$  is calculated by the formula below.

$$V_{OH} = \frac{R_p}{1000 + R_p} \times 10.5(V)$$

See below for the block part of the operation.

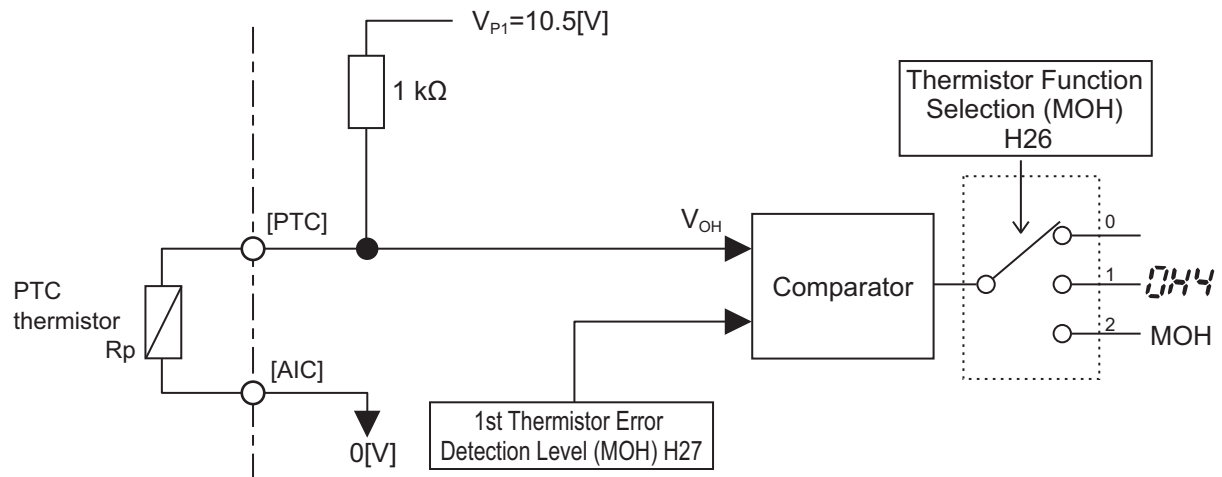

### 7-8-6 Frequency Arrival Signal (FAR1 to 3, FDT1 to 4, FAR1FDT1)

The inverter outputs the frequency arrival signal when the output frequency reaches the set level.

Allocate “1: FAR1 (Frequency arrival signal 1 (constant speed)),” “2: FDT1 (Over set frequency arrival signal 1),” “21: FAR2 (Frequency arrival signal 2),” “31: FDT2 (Over set frequency arrival signal 2),” “72: FAR3 (Frequency arrival signal 3),” “87: FAR1FDT1 (Frequency match detection),” “183: FDT3 (Set-frequency-only arrival signal),” or “185: FDT4 (Set-frequency-only arrival signal 2)” to Output Terminal [DO1] Function Selection (E20), Output Terminal [DO2] Function Selection (E21) and Output Terminal [ROA, ROB] Function Selection (E27).

Parameter No.	Function name	Data	Default data	Unit
E20, E21, E27	Output Terminal [DO1] Function Selection, Output Terminal [DO2] Function Selection, Output Terminal [ROA, ROB] Function Selection	1: FAR1 (Frequency arrival signal 1 (constant speed)) 2: FDT1 (Over set frequency arrival signal 1) 21: FAR2 (Frequency arrival signal 2) 31: FDT2 (Over set frequency arrival signal 2) 72: FAR3 (Frequency arrival signal 3) 87: FAR1FDT1 (Frequency match detection) 183: FDT3 (Set-frequency-only arrival signal) 185: FDT4 (Set-frequency-only arrival signal 2)	-	
E29	Frequency Arrival 2 ON Timer (FAR2)	0.01 to 10.00	0.10	s

Parameter No.	Function name	Data	Default data	Unit
E30	Frequency Arrival Detection Width (FAR1/FAR2/FAR3/FDT3/FDT4)	0.0 to 10.0	2.5	Hz
E31	Frequency Detection Level1 (FDT1/FDT3)	0.0 to 590.0	60.0	Hz
E32	Frequency Detection Hysteresis Width (FDT1/FDT2)	0.0 to 590.0	1.0	Hz
E36	Frequency Detection Level 2 (FDT2/FDT4)	0.0 to 590.0	60.0	Hz

### Frequency Arrival Signal (Constant Speed) (E20, E21, E27 = 1: FAR1, 21: FAR2, 72: FAR3)

FAR1, FAR2 and FAR3 turn ON when the output frequency falls within the set frequency  $\pm$  Frequency Arrival Detection Width (E30), and turn OFF when the output frequency falls outside the Frequency Arrival Detection Width (E30). In addition to FAR1 signal functions, the Frequency Arrival 2 ON Timer (E29) can be set to the FAR2 signal.

Also, operation when the RUN command is OFF differs between FAR1, FAR2 and FAR3 as follows.

FAR1, FAR2: The signal is always OFF when the RUN command is OFF or the speed command is 0.

FAR3: The signal is turned ON when the output frequency is within  $0 \pm$  frequency arrival detection range while the frequency reference is considered to be 0 with the RUN command being OFF.

Name	Output signal	E20, E21, E27 allocated data	Operation level	Detection range	Remarks
Frequency arrival signal 1 (constant speed)	FAR1	1	Set frequency	Frequency Arrival Detection Width (E30)	OFF when the RUN command is OFF
Frequency arrival signal 2 (constant speed)	FAR2	21	Set frequency	Frequency Arrival Detection Width (E30)	OFF when the RUN command is OFF
Frequency arrival signal 3 (constant speed)	FAR3	72	Set frequency	Frequency Arrival Detection Width (E30)	When the RUN command is OFF, the set frequency is treated and processed as 0

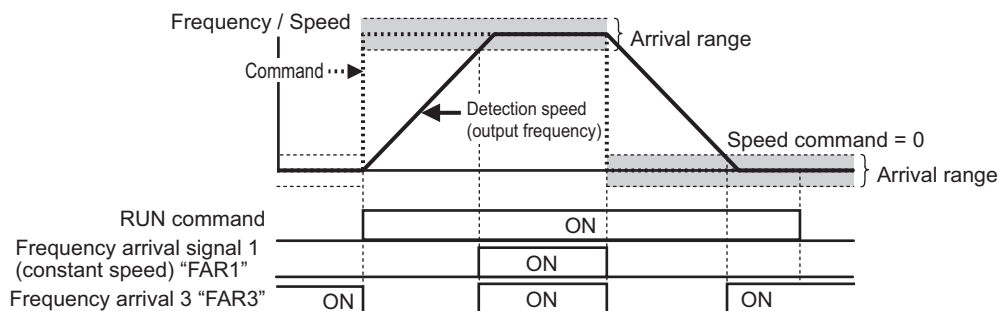

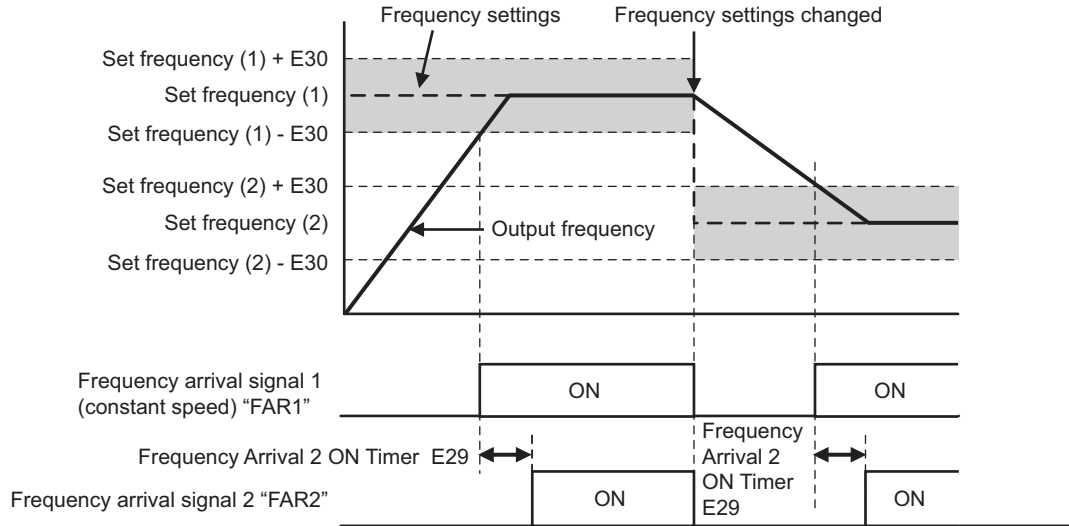

### Over Set Frequency Arrival Signal (E20, E21, E27 = 2: FDT1, 31: FDT2)

An ON signal is output when the output frequency becomes equal to or higher than the operation level (E31/E36) set in the frequency detection, and the signal is turned OFF when the frequency falls below Frequency Detection Hysteresis Width (FDT1/ FDT2) (E32).

Name	Output signal	E20, E21, E27 allocated data	Operation level	Hysteresis width
			Range: 0.0 to 500.0 Hz	Range: 0.0 to 500.0 Hz
Over set frequency arrival signal 1	FDT1	2	E31	E32
Over set frequency arrival signal 2	FDT2	31	E36	E32

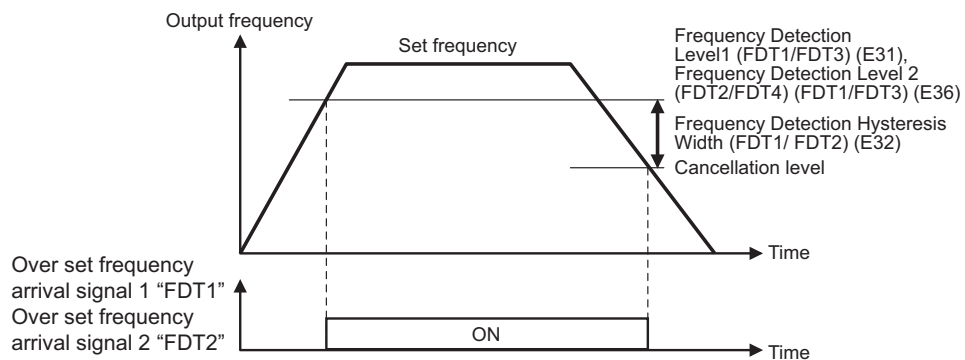

### Set-frequency-only Arrival Signal (E20, E21, E27 = 183: FDT3, 185: FDT4)

An ON signal is output when the output frequency is within the range of the operation level (E31/E36) set in the frequency detection, and the signal is turned OFF when the frequency is out of range.

Name	Output signal	E20, E21, E27 allocated data	Operation level	Frequency arrival detection width
			Range: 0.0 to 500.0 Hz	Range: 0.0 to 10.0 Hz
Set-frequency-only arrival signal	FDT3	183	E31	E30
Set-frequency-only arrival signal 2	FDT4	185	E36	E30

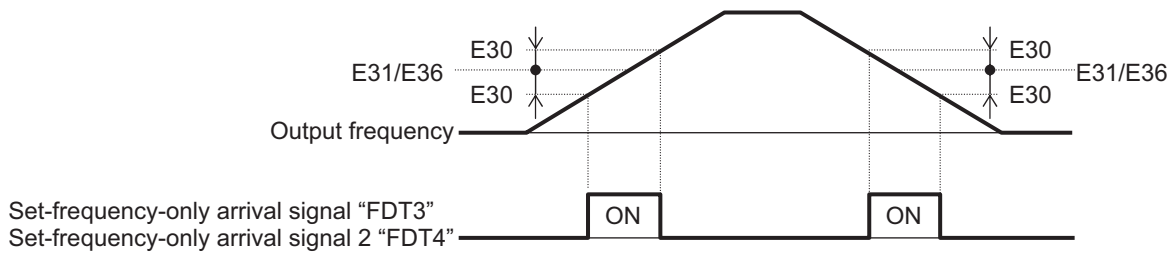

### Frequency Match Detection (E20, E21, E27 = 87: FAR1FDT1)

This is an AND composite signal of FAR1 and FDT1, which turns ON when both the conditions are established.

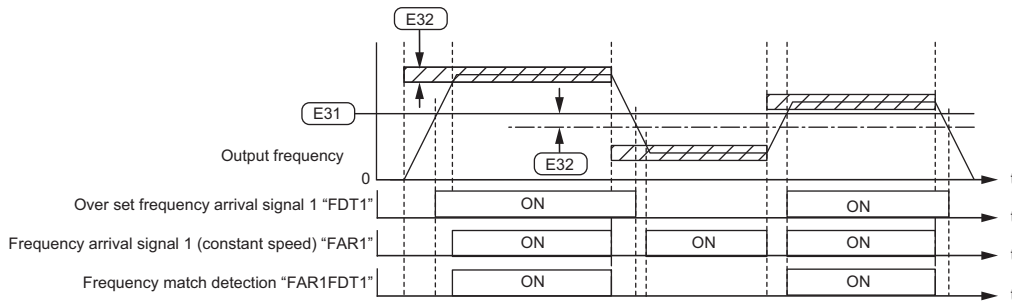

### 7-8-7 Power ON Time Over/RUN Time (ONT/RNT)

- If the total RUN time and power ON time of the inverter main circuit exceeds the time set at RUN Time Over (RNT)/Power ON Time Over (ONT) Detection Level (E154), the inverter will output the RUN time over/Power ON time over (RNT/ONT) signal.

Parameter No.	Function name	Data	Default data	Unit
E154	RUN Time Over (RNT)/ Power ON Time Over (ONT) Detection Level	0: Function disabled 1 to 9999 [x10h] (10 to 99.990 hours)	0	10 hex



Parameter No.	Function name	Data	Default data	Unit
E20, E21, E27	Output Terminal [DO1] Function Selection, Output Terminal [DO2] Function Selection, Output Terminal [ROA, ROB] Function Selection	237: RNT (RUN time over) 236: ONT (Power ON time over)	-	-
Related function		Cumulative Operation Time (M20), Total RUN Time Monitor (W179)		

## Power ON Time Over (236: ONT)

- To output this signal, allocate “236: ONT” to Output Terminal [DO1] Function Selection (E20), Output Terminal [DO2] Function Selection (E21) or Output Terminal [ROA, ROB] Function Selection (E27).
- The power ON time of the inverter's main circuit is counted and output to Cumulative Operation Time (M20). When RUN Time Over (RNT)/Power ON Time Over (ONT) Detection Level (E154) elapses, the ONT terminal (236: Power ON time over) turns ON.

## RUN time over (238: RNT)

- To output this signal, allocate “238: RNT” to Output Terminal [DO1] Function Selection (E20), Output Terminal [DO2] Function Selection (E21) or Output Terminal [ROA, ROB] Function Selection (E27).
- Time is measured during inverter operation (inverter output signal (35: RUN2) is ON) and the result is output to Total RUN Time Monitor (W179). When RUN Time Over (RNT)/Power ON Time Over (ONT) Detection Level (E154) elapses, RNT terminal (238: RUN time over) turns ON.

### 7-8-8 Maintenance monitor

The Maintenance timer counted up (MNT) signal is output when the cumulative operation time for motor 1 exceeds the preset time, or when the number of startups for motor 1 exceeds the preset number of times.

Parameter No.	Function name	Data	Default data	Unit
H78	1st Motor Maintenance Interval	0: Disable 1 to 9999: Maintenance interval (in 10 hours)	8760	Time
H94/A51	1st Cumulative Motor Run Time/2nd Cumulative Motor Run Time	0 to 9999 (Counted automatically as the operation time elapses)	0	Time
H79	1st Preset Startup Count for Motor Maintenance	0: Disable 1 to 65535: Preset startup count for maintenance	0	Times
H44/A52	1st Startup Count for Motor/2nd Startup Counter for Motor	0 to 65535 (Counted automatically during startup)	0	Times

Parameter No.	Function name	Data	Default data	Unit
E20, E21, E27	Output Terminal [DO1] Function Selection, Output Terminal [DO2] Function Selection, Output Terminal [ROA, ROB] Function Selection	84: MNT (Maintenance timer counted up)	-	-

## Maintenance timer counted up (E20, E21, E27 = 84: MNT)

To output this signal, allocate “84: MNT (Maintenance timer counted up)” to Output Terminal [DO1] Function Selection (E20), Output Terminal [DO2] Function Selection (E21) and Output Terminal [ROA, ROB] Function Selection (E27).

The signal is output when 1st Startup Count for Motor (H44) reaches the value set at 1st Preset Startup Count for Motor Maintenance (H79), or 1st Cumulative Motor Run Time (H94) reaches the value set at 1st Motor Maintenance Interval (H78).

This function is exclusively for the 1st control. The maintenance timer signal is not output even if 2nd Cumulative Motor Run Time (A51)/2nd Startup Counter for Motor (A52) exceeds the set time period or set number of times.

<For half-yearly maintenance>

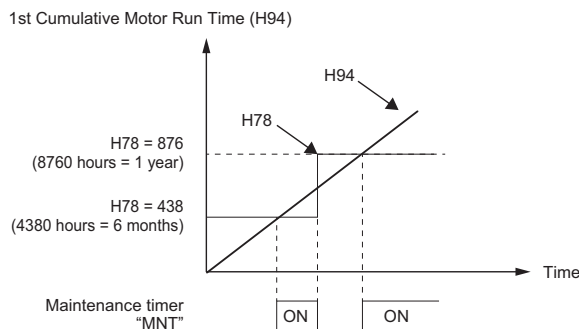

<For maintenance performed every 1,000 times>

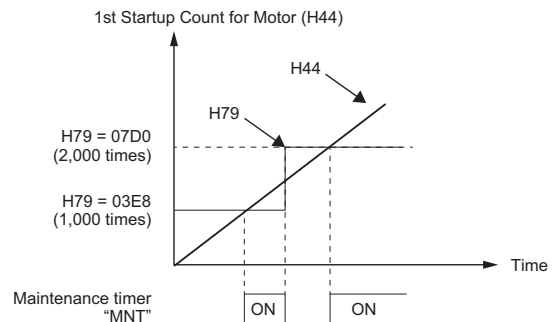

When the maintenance time is reached, or when the set number of startups for maintenance is reached, again set a numeric value at 1st Motor Maintenance Interval (H78) or 1st Preset Startup Count for Motor Maintenance (H79), and press the  key to reset the output signal, and restart the measurement of the time period or the number of startups.

## 7-8-9 Logic Operation Output Signal (LOG1 to LOG3)

Logical operations (AND, OR, XOR) are performed on signals that can be allocated to output terminals [DO1], [DO2] and [ROA, ROB], and the result can be output from output terminals. Set “206: LOG1 (Logic operation output 1),” “207: LOG2 (Logic operation output 2),” or “208: LOG3 (Logic operation output 3)” at Output Terminal [DO1] Function Selection (E20), Output Terminal [DO2] Function Selection (E21) and Output Terminal [ROA, ROB] Function Selection (E27). However, “206: LOG1 (Logic operation output 1)” to “208: LOG3 (Logic operation output 3)” cannot be selected for the operation target data.

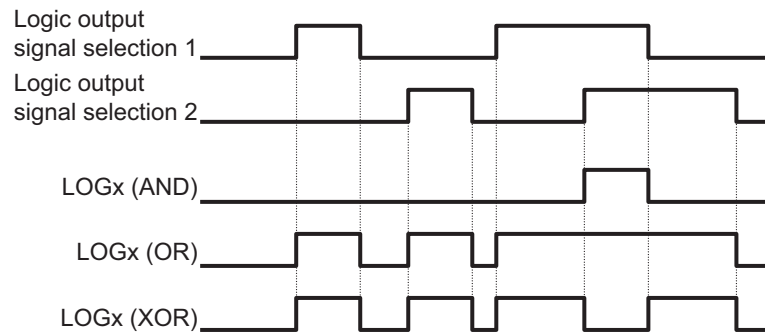

Parameter No.	Function name	Data	Default data	Unit
H315, H318, H321	Logical Expression 1 Operation Target 1 Logical Expression 2 Operation Target 1 Logical Expression 3 Operation Target 1	0 to 241: Same as the options for E20, E21 and E27 (Except 206 to 208: LOG1 to LOG3)	0	-
H316, H319, H322	Logical Expression 1 Operation Target 2 Logical Expression 2 Operation Target 2 Logical Expression 3 Operation Target 2		0	-
H317, H320, H323	Logical Expression 1 Logical Operator Logical Expression 2 Logical Operator Logical Expression 3 Logical Operator	0: AND 1: OR 2: XOR	0	-
E20, E21, E27	Output Terminal [DO1] Function Selection, Output Terminal [DO2] Function Selection, Output Terminal [ROA, ROB] Function Selection	206: LOG1 (Logic operation output 1) 207: LOG2 (Logic operation output 2) 208: LOG3 (Logic operation output 3)	0	-

Each logic operation output signal requires different parameter settings.

Set the necessary parameters according to the table below.

Selected signal	Logic output signal selection 1	Logic output signal selection 2	Operator selection
206: Logic operation output 1 (LOG1)	H315	H316	H317
207: Logic operation output 2 (LOG2)	H318	H319	H320
208: Logic operation output 3 (LOG3)	H321	H322	H323

(Example) To output the result of the AND operation between Run Signal (0: RUN) and Over set frequency arrival signal 1 (2: FDT1) to the multifunction output terminal DO2 as a Logic operation output 1 (LOG1).

Output Terminal [DO2] Function Selection (E21): 206 (LOG1)

Logical Expression 1 Operation Target 1 (H315): 0 (RUN)

Logical Expression 1 Operation Target 2 (H316): 2 (FDT1)

Logical Expression 1 Logical Operator (H317): 0 (AND)

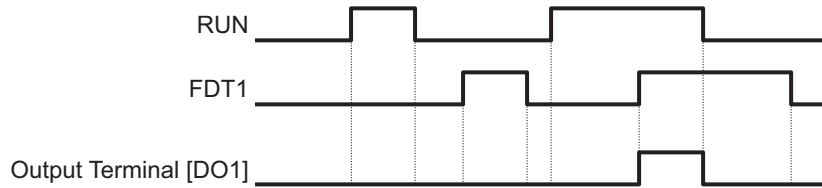

### 7-8-10 Capacitor Life Warning Signal (WAC)

Use this signal to determine the life expectancy of the internal capacitor based on the inverter's internal temperature, conduction time, and the capacity of the capacitor.

By turning bit 4 of Protection/Maintenance Function Mode Selection (H98) ON, the service life of the capacitor is judged to have reached its end when any one of the following conditions is satisfied, and WAC (Capacitor life warning signal) is turned ON.

- The capacity of the capacitor becomes 85% or below the factory default value.
- The conduction time exceeds 61,000 hours (7 years) in all models of the HND mode "A2022/037, A4022/040, AB002-022" and ND mode.
- The conduction time exceeds 87,000 hours (10 years) in models other than the above.

The capacity of the capacitor can be monitored by "Main circuit capacitor's capacity monitor (Monitor mode: 5\_05)", and the conduction time by "Service life of DC link bus capacitor (Elapsed time) (Monitor mode: 5\_26)."

This function is set based on *A-2 Smoothing Capacitor Life Curve* on page A-6.

The time until the service life of the main circuit capacitor is reached (in 10 hours) is displayed in Service Life of Main Circuit Capacitor Remaining Time (H77).

Parameter No.	Function name	Data	Default data	Unit
H98	Protection/Maintenance Function Mode Selection	bit 4: Judge main circuit capacitor life	-	-
E20, E21, E27	Output Terminal [DO1] Function Selection, Output Terminal [DO2] Function Selection, Output Terminal [ROA, ROB] Function Selection	240: WAC (Capacitor life warning signal)	-	-

### Method for Comparing the Main Circuit Capacitor's Capacity and the Default Value during Shipment from Factory

When bit 3 = 0 at Protection/Maintenance Function Mode Selection (H98), follow the measurement procedure below to measure the capacitance of the main circuit capacitor when the power supply is cut off, and compare the value with the default value at the time of shipment from the factory. The

measurement result is displayed as a percentage (%) with respect to the default value at the time of shipment from the factory.

### Capacity measurement procedure

1. To compare with the default value measured at the time of shipment from the factory, return the state of the actual product to the state during shipment from the factory.
  - If another inverter is connected to the main circuit terminals P(+) and N(-) via a DC bus line, disconnect it. A DC reactor (option), even if connected, need not be removed.
  - Remove the wires of the control power auxiliary inputs (R0, T0).
  - Turn OFF all digital inputs (DI1 to DI7) of the control circuit terminals.
  - Make the setting to ensure that the transistor output (DO1, DO2) and relay output (ROA, ROB) do not turn ON.
  - Stop the RS-485 communications of the inverter.
  - If the setting is made to perform logical inversion of the transistor output and relay output, the output turns ON even when the inverter is not running. In such a case, change the setting.
  - Ensure an ambient temperature of  $25^{\circ}\text{C}\pm 10^{\circ}\text{C}$ .
2. Turn ON the main power supply.
3. Make sure the cooling fan is operating and the inverter is in a stopped state.
4. When the main power supply is cut off, the measurement of the capacity of the main circuit capacitor starts automatically. Make sure the display on the LED monitor is "\_\_\_\_." If "\_\_\_\_" is not displayed on the LED monitor, the measurement is not started. Check the conditions in (1).
5. Once the display on the LED monitor is cleared, again turn ON the main power supply.
6. Move to menu No. 5 "Maintenance Information" in the program mode, and check the percentage (%) of capacitance of the main circuit capacitor (monitor No. 5\_05).

## Method of Measuring the Capacity of the Main Circuit Capacitor when Power Supply is Cut Off during Normal Operation

The capacity of the main circuit capacitor in the normal operation state is measured automatically when the power supply is cut off, if bit 3 = 1 at Protection/Maintenance Function Mode Selection (H98).

To perform this measurement, it is necessary to measure the reference capacitor capacity according to the measurement procedure below.

Parameter No.	Function name	Description
H42	Main Circuit Capacitor Service Life Coefficient (Measurement Value)	<ul style="list-style-type: none"> <li>• Measurement value when the capacity of the main circuit capacitor is measured</li> <li>• Start the default value measurement mode during normal operation (0000)</li> <li>• Measurement failure (0001)</li> </ul>
H47	Main Circuit Capacitor Service Life Coefficient (Initial Value)	<ul style="list-style-type: none"> <li>• Default value of the main circuit capacitor</li> <li>• Start the default value measurement mode during normal operation (0000)</li> <li>• Measurement failure (0001)</li> </ul>

When a part is replaced, it is necessary to clear or replace the data at Main Circuit Capacitor Service Life Coefficient (Measurement Value) (H42) and Main Circuit Capacitor Service Life Coefficient (Initial Value) (H47).

### Reference capacity measurement procedure

1. Change Protection/Maintenance Function Mode Selection (H98) to user measurement value standard (bit 3 = 1).
2. Stop the inverter.
3. Set the inverter to a state when the power supply is cut off during normal operation.
4. Set Main Circuit Capacitor Service Life Coefficient (Measurement Value) (H42) and Main Circuit Capacitor Service Life Coefficient (Initial Value) (H47) to 0000, respectively.
5. Cut off the power supply to the inverter (the operation described below is executed automatically when the power is cut off).

Measure the discharge time of the main circuit capacitor and save it to Main Circuit Capacitor Service Life Coefficient (Initial Value) (H47).

The measurement conditions for main circuit capacitor are detected automatically, and the conditions are saved.

The LED during measurement displays “\_\_\_\_\_.”

6. Turn ON the inverter power supply again.

Make sure Main Circuit Capacitor Service Life Coefficient (Measurement Value) (H42) and Main Circuit Capacitor Service Life Coefficient (Initial Value) (H47) are correct.

Move to menu number 5 “Maintenance Information” in the program mode, and make sure the percentage (%) of capacitance of the main circuit capacitor is 100%.

If measurement fails, 0001 is set respectively at Main Circuit Capacitor Service Life Coefficient (Measurement Value) (H42) and Main Circuit Capacitor Service Life Coefficient (Initial Value) (H47). Remove the cause of the failure and perform measurement again.

If the conditions described above are satisfied when the power supply is cut off the next time, the discharge time of the main circuit capacitor is measured automatically. Periodically move to menu number 5 “Maintenance Information” in the program mode, and check the percentage (%) of capacitance of the main circuit capacitor.

- A large measurement error may occur in the measurement method described above. If life estimation is performed in this mode, return the judgment standard for the service life of the main circuit capacitor in Protection/Maintenance Function Mode Selection (H98) to the factory default standard, perform the measurement again under the factory default conditions, and check the service life.

### 7-8-11 Braking Transistor Broken (DBAL)

Use this signal to determine the life expectancy of the internal capacitor based on the inverter’s internal temperature, conduction time, and the capacity of the capacitor.

When bit 6 = 1 at Protection/Maintenance Function Mode Selection (H98), an error in the built-in braking transistor is detected, the inverter is topped, and the braking transistor error (alarm code: dba) is displayed.

When bit 6 = 0 at Protection/Maintenance Function Mode Selection (H98), the braking transistor is not used and an alarm does not occur.

Bit	Function	Data	Default data	Unit
E20, E21, E27	Output Terminal [DO1] Function Selection, Output Terminal [DO2] Function Selection, Output Terminal [ROA, ROB] Function Selection	105: DBAL (Braking transistor broken)	-	-

### 7-8-12 Cooling FAN Control Method Selection

To extend the life of the cooling fan and reduce the noise from the cooling fan, the cooling fan can be stopped according to the internal temperature of the inverter when there is no motor output.

Parameter No.	Function name	Data	Default data	Unit
H06	Cooling Fan Function Selection	0: Always Fan ON 1: ON/OFF control effective	0	-
E20, E21, E27	Output Terminal [DO1] Function Selection, Output Terminal [DO2] Function Selection, Output Terminal [ROA, ROB] Function Selection	25: FAN (Cooling fan in operation)	-	-

- When Cooling Fan Function Selection (H06) is set to “1: ON/OFF control effective,” the cooling fan operates during motor output, and, when the motor is stopped, the cooling fan operates until the internal temperature of the inverter is at a fixed value or less.
- When Cooling Fan Function Selection (H06) is set to “1: ON/OFF control effective,” the ON signal is output when the cooling fan is in operation and the OFF signal is output when it has stopped by allocating “25: FAN (Cooling fan in operation)” to Output Terminal [DO1] Function Selection (E20), Output Terminal [DO2] Function Selection (E21) and Output Terminal [ROA, ROB] Function Selection (E27).

### 7-8-13 Cooling Fan Life Warning Signal (WAF)

The number of hours of operation of the cooling fan is counted. The cooling fan is judged to have reached the end of its life when it exceeds 87,000 hours (10 years) of operation, and WAF (Cooling fan life warning signal) is turned ON.

The operation time of the cooling fan can be monitored by “Cooling fan cumulative run time monitor (Monitor mode: 5\_07).”

When the cooling fan is replaced, the operation time can be cleared by setting 0.

Parameter No.	Function name	Data	Default data	Unit
E20, E21, E27	Output Terminal [DO1] Function Selection, Output Terminal [DO2] Function Selection, Output Terminal [ROA, ROB] Function Selection	241: WAF (Cooling fan life warning signal)	-	-
H43	Cumulative Run Time of Cooling Fan	0 to 9,999 (in 10 hours)	0	10 hex

### 7-8-14 Lifetime Alarm (LIFE)

For models with a main circuit capacitor, cooling fan, and inverter capacity of 18.5 kW or more, if any of the capacitors including electrolytic capacitors exceeds the life judgment standard, the LIFE terminal (30: Lifetime alarm) is turned ON. In addition, the lifetime alarm (alarm code: LiF) can be output as a minor alarm. (For details, refer to 7-8-26 *Light Alarm Selection* on page 7-108.)

Parameter No.	Function name	Data	Default data	Unit
E20, E21, E27	Output Terminal [DO1] Function Selection, Output Terminal [DO2] Function Selection, Output Terminal [ROA, ROB] Function Selection	30: LIFE (Lifetime alarm)	-	-

	Detection method	Individual output terminal*1	Monitor No. (only for ST)	Remarks
Main circuit capacitor	Measure the discharge time of the main circuit capacitor when the main power supply is shut off and calculate the capacity of the main circuit capacitor. It is judged that the end of life has been reached when capacity has reached 85% of the factory default capacitor capacity or the main circuit capacitor capacity (pre-measured at startup) in a user normal operation state.	WAC terminal (240: WAC)	Monitor No. 5_05 (Parameter No. W75)	Adjustment is possible (For details, refer to 7-8-10 <i>Capacitor Life Warning Signal (WAC)</i> on page 7-96.) Can be disabled by Protection/Maintenance Function Mode Selection (H98).
	The time during which voltage is applied to the main circuit capacitor (the time during which the main power supply is ON) is counted. Also, the time is corrected by measuring the capacity of the main circuit capacitor. When the operation time exceeds 87,000 hours (10 years)*2, it is judged that the end of life has reached.		Elapsed time Monitor No. 5_26 (Parameter No. M76) Remaining time Monitor No. 5_27 (Parameter No. M77)	Can be reset by Service Life of Main Circuit Capacitor Remaining Time (H77).
Electrolytic capacitor	The time during which voltage is applied to the electrolytic capacitor is counted. Also, the elapsed time is corrected by the ambient temperature. When the operation time exceeds 87,000 hours (10 years), it is judged that the end of life has reached.	-	Monitor No. 5_06 (Parameter No. W67)	Can be reset by Cumulative Run Time of Electrolytic capacitor (H48).



	Detection method	Individual output terminal*1	Monitor No. (only for ST)	Remarks
Cooling fan	The time during which the cooling fan is operating is counted. When the operation time exceeds 87,000 hours (10 years), it is judged that the end of life has reached.	WAF terminal (241: WAF)	Monitor No. 5_07 (Parameter No. W68)	Can be reset by Cumulative Run Time of Cooling Fan (H43).

\*1. Select by output terminal function selection.

\*2. With specifications and models shown below, the life is 61,000 hours (7 years) according to Load Mode Selection (F80).

HND mode: A2022/037, A4022/040, AB002-022

ND mode: All models

### 7-8-15 Communications Disconnection Detection Signal (NDc)

If communication is lost during Modbus communication, this signal is turned ON until the next data is received.

Set the time until the reception timeout at RS-485 Communication Timeout Time (y18).

The monitoring timer that detects the reception timeout starts under the following AND conditions.

- The communication protocol setting is Modbus-RTU.
- “14: RS-485 communication” is set to Frequency Reference Selection (F01/C30) or “4: RS-485 communication” is set to RUN Command Selection (F02/E102).
- RUN command ON
- Other than 0 is set to RS-485 Communication Timeout Time (y18).

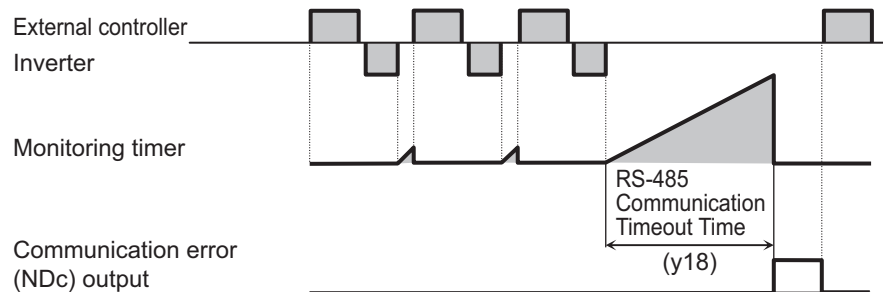

Parameter No.	Function name	Data	Default data	Unit
y18	RS-485 Communication Timeout Time	0: Not check of the time-out (OFF) 1 to 60	0	s
E20, E21, E27	Output Terminal [DO1] Function Selection, Output Terminal [DO2] Function Selection, Output Terminal [ROA, ROB] Function Selection	209: NDc (Network error)	-	-

For details on communication, refer to *Section 8 Communications Functions* on page 8-1.

### 7-8-16 Starting Contact Signal (FR)

The starting contact signal is output for the duration that the “FW” terminal or “RV” terminal is being input.

The inverter will stop if the FW and RV terminals are input simultaneously, and the FR terminal (187: Starting contact signal) turns OFF.

Parameter No.	Function name	Data	Default data	Unit
E20, E21, E27	Output Terminal [DO1] Function Selection, Output Terminal [DO2] Function Selection, Output Terminal [ROA, ROB] Function Selection	187: FR (Starting contact signal)	-	-

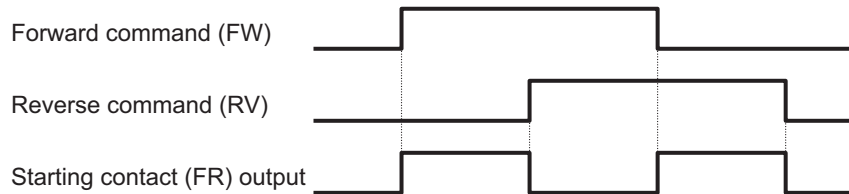

### 7-8-17 Cooling Fin Overheat Warning (OHF)

This function monitors the temperature of the cooling fin of the inverter and turns the cooling fin overheat warning signal ON/OFF according to the conditions below.

- When the cooling fin overheat warning signal is OFF  
The cooling fin overheat warning signal turns ON when the cooling fin temperature is overheat trip temperature - 5°C or above.
- When the cooling fin overheat warning signal is ON  
The cooling fin overheat warning signal turns OFF when the cooling fin temperature is overheat trip temperature - 8°C or below.
- When the cooling fin temperature is the overheat trip temperature or above, cooling fin overheat occurs (alarm code: OH1).

Parameter No.	Function name	Data	Default data	Unit
E20, E21, E27	Output Terminal [DO1] Function Selection, Output Terminal [DO2] Function Selection, Output Terminal [ROA, ROB] Function Selection	28: OHF (Fin overheat warning)	-	-

### 7-8-18 Low Current Signal (LOC)

This Light load detection signal (LOC) is output when the output current falls to or below 1st Overload Early Warning Detection Level (E37).

At Low Current Detection Condition Selection (LOC) (E184), select whether to have the inverter output this signal constantly during run or only during constant speed operation.

Parameter No.	Function name	Data	Default data	Unit
E37	1st Overload Early Warning Detection Level	0.00: Disable 0.01 to 3000 A	21.00	A

Parameter No.	Function name	Data	Default data	Unit
E38	1st Overload Early Warning Detection Timer / Low Current detection level (OL, LOC)	0.01 to 600.00	10.00	s
E184	Low Current Detection Condition Selection (LOC)	0: Output during acceleration/deceleration and constant-speed operation 1: Output only during constant-speed operation*1	-	-
E20, E21, E27	Output Terminal [DO1] Function Selection, Output Terminal [DO2] Function Selection, Output Terminal [ROA, ROB] Function Selection	41: LOC (Light load detection signal)	-	-
Related function		Output Terminal [DO1] ON Delay Time (H309), Output Terminal [DO2] ON Delay Time (H311), Output Terminal [ROA, ROB] ON Delay Time (H313), Output Terminal [DO1] OFF Delay Time (H310), Output Terminal [DO2] OFF Delay Time (H312), Output Terminal [ROA, ROB] OFF Delay Time (H314)		

- \*1. If analog input (F01/C30 = 1, 2, 3, 5) is selected for 1st Frequency Reference Selection (F01)/2nd Frequency Reference Selection (C30), the signal may not be judged as a constant speed depending on the sampling condition. In this case, set E184 = 0 (Output during acceleration/deceleration and constant-speed operation), or increase the value set at Input Terminal [AI1] Filter (C33).

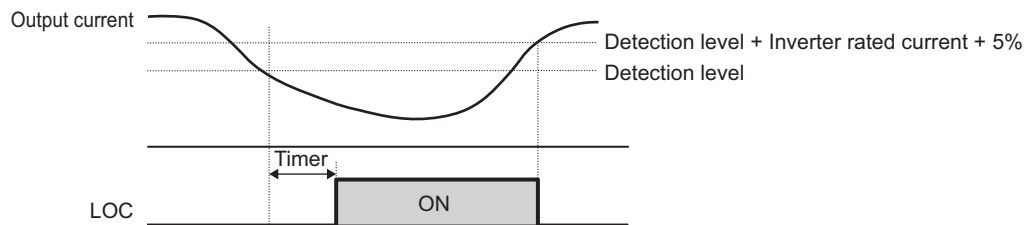

### 7-8-19 Window Comparator/Disconnection Detection (AI1Dc/AIIDc/AIVDc)

The window comparator signal is output when the input value of the analog input terminals [AI1], [AI2] (AII) and [AI2] (AIV) is between the upper and lower limit level of the window comparator. It is useful for monitoring the analog input at a level to detect disconnection or other faults.

Set the detection upper limit level by Analog Input [AI1] Detection Upper Limit Level (E157)/Analog Input [AI2] Detection Upper Limit Level (E160), detection lower limit level by Analog Input [AI1] Detection Lower Limit Level (E158)/Analog Input [AI2] Detection Lower Limit Level (E161) and detection hysteresis width by Analog Input [AI1] Level Detection Hysteresis Width (E159)/Analog Input [AI2] Level Detection Hysteresis Width (E162) for each of analog input terminals [AI1] and [AI2] (AII/AIV).

Analog operation level at AI1Dc/AIIDc/AIVDc output can be set to any value by Analog Operation Level at [AI1] Disconnection (E163)/Analog Operation Level at [AI2] Disconnection (E164). When set to 999, the analog input value will be used as is.

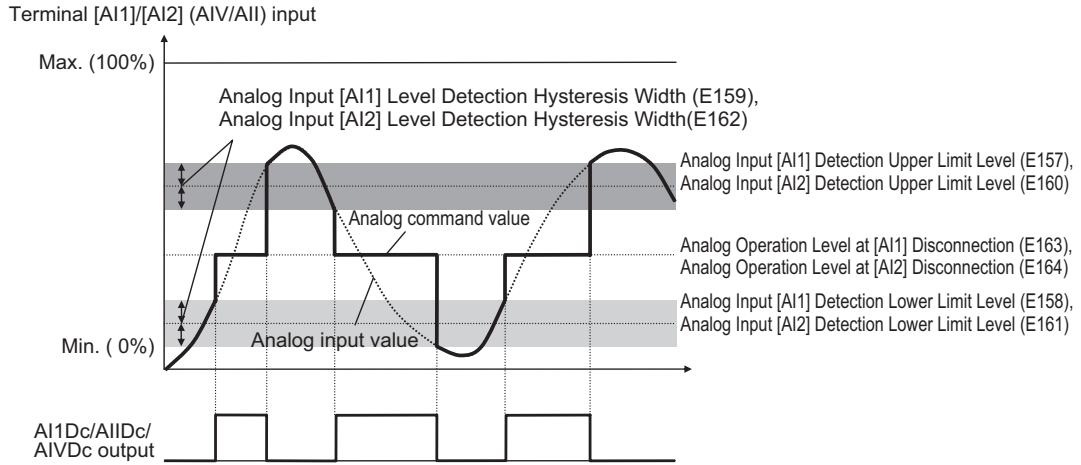

Parameter No.	Function name	Data	Default data	Unit
E157	Analog Input [AI1] Detection Upper Limit Level	0 to 100%	100	%
E160	Analog Input [AI2] Detection Upper Limit Level			
E158	Analog Input [AI1] Detection Lower Limit Level	0 to 100%	0	%
E161	Analog Input [AI2] Detection Lower Limit Level			
E159	Analog Input [AI1] Level Detection Hysteresis Width	0 to 100%	0	%
E162	Analog Input [AI2] Level Detection Hysteresis Width			
E163	Analog Operation Level at [AI1] Disconnection	-100 to 100, 999: Disable	999	%
E164	Analog Operation Level at [AI2] Disconnection	0 to 100, 999: Disable		
E20, E21, E27	Output Terminal [DO1] Function Selection, Output Terminal [DO2] Function Selection, Output Terminal [ROA, ROB] Function Selection	238: AI1Dc (Analog AI1 disconnection detection / Window comparator) 59: AI1Dc (Analog AI2 (AII) disconnection detection / Window comparator) 239: AIVDc (Analog AI2 (AIV) disconnection detection / Window comparator)	-	-

Note: Set the upper and lower limit level settings for the window comparator function as a percentage [%] of the input voltage (10 V) or input current (20 mA) rather than making the start and end settings for each analog input.

**Additional Information**

When using this signal for disconnection detection, set the disconnection detection level to Analog Input [AI1] Detection Upper Limit Level (E157)/Analog Input [AI2] Detection Upper Limit Level (E160).

(During normal operation, range exceeding the upper limit value is used. If the range falls below the lower limit value, a disconnection will be detected.)

**7-8-20 Frequency Reference Selection Status Signal (FREF)**

This signal is output when the frequency reference is set to Operator (Frequency Reference Selection (F01/C30) = 0, 8), or when the forced operator function (35: OPE terminal) is allocated.

The signal is OFF when the frequency reference is input via other than the Digital Operator.

Parameter No.	Function name	Data	Default data	Unit
E20, E21, E27	Output Terminal [DO1] Function Selection, Output Terminal [DO2] Function Selection, Output Terminal [ROA, ROB] Function Selection	188: FREF (Frequency Command Source)	-	-

**7-8-21 RUN Command Status Signal (REF)**

This signal is output when the RUN command selection is set to Operator (RUN Command Selection (F02/E102) = 0, 2, 3), or when the forced operator function (35: OPE) is allocated.

The signal is OFF when the RUN command selection is set to other than the Operator.

Parameter No.	Function name	Data	Default data	Unit
E20, E21, E27	Output Terminal [DO1] Function Selection, Output Terminal [DO2] Function Selection, Output Terminal [ROA, ROB] Function Selection	8: REF (RUN command Source)	-	-

**7-8-22 2nd control under selection signal (SETM, SWM1)**

The SETM signal is output when the SET terminal (12: Set 2nd control) of multifunction input is ON and the 2nd control has been selected. If the SET terminal is OFF and the 1st control has been selected, the SWM1 signal is output.

Parameter No.	Function name	Data	Default data	Unit
E20, E21, E27	Output Terminal [DO1] Function Selection, Output Terminal [DO2] Function Selection, Output Terminal [ROA, ROB] Function Selection	48: SWM1 (1st motor in operation) 49: SETM (2nd motor in operation)	-	-

### 7-8-23 Inverter Output Limiting (IOL, IOL2)

This signal is output when the inverter is performing one of the limitation operations described below. (Minimum output signal width 100 ms) The signal is output when the limitation operation in “22: IOL2 (Inverter output limiting with delay)” continues for 20 ms or longer.

- Torque limit operation  
Torque Limit 1/2/3/4 (F40/F41/E16/E17)
- Current limitation operation by software  
Overload Protect Function Selection (F43/E146), Overload Protect Level (F44/E147)
- Current limitation operation by hardware  
Instantaneous Overcurrent Limiting Function Selection (H12)
- Anti-regenerative Control (H69)  
Anti-regenerative Control Function Selection (H69)
- Overload Stop Mode (J65)  
Overload Stop Mode Selection (J65)

Parameter No.	Function name	Data	Default data	Unit
E20, E21, E27	Output Terminal [DO1] Function Selection, Output Terminal [DO2] Function Selection, Output Terminal [ROA, ROB] Function Selection	5: IOL (Inverter output limiting) 22: IOL2 (Inverter output limiting with delay)	-	-
Related function		Output Terminal [DO1] ON Delay Time (H309) Output Terminal [DO2] ON Delay Time (H311) Output Terminal [ROA, ROB] ON Delay Time (H313) Output Terminal[DO1] OFF Delay Time (H310) Output Terminal[DO2] OFF Delay Time (H312) Output Terminal [ROA, ROB] OFF Delay Time (H314)		

The OFF delay becomes the time obtained by adding 0.1 s to Output Terminal [DO1] OFF Delay Time (H310), Output Terminal [DO2] OFF Delay Time (H312) and Output Terminal [ROA, ROB] OFF Delay Time (H314).

- When the IOL signal or the ILO2 signal is ON, the output frequency of the inverter is automatically controlled by the limitation processes described above, and thus, the set frequency may not be achieved.

### 7-8-24 Low-To-Moderate Voltage Detection (U-EDC)

This signal turns ON when the Main Circuit DC Voltage becomes equal to or below Main Circuit DC Voltage low-voltage detection level (E76), and turns OFF when it becomes above the Main Circuit DC Voltage low-voltage detection level (E76).

Parameter No.	Function name	Data	Default data	Unit
E76	Main Circuit DC Voltage Low-voltage Detection Level	200 to 400 V (200 V series) 400 to 800 V (400 V series)	235	V

Parameter No.	Function name	Data	Default data	Unit
E20, E21, E27	Output Terminal [DO1] Function Selection, Output Terminal [DO2] Function Selection, Output Terminal [ROA, ROB] Function Selection	77: U-EDC (Low DC link bus voltage detection)	-	-

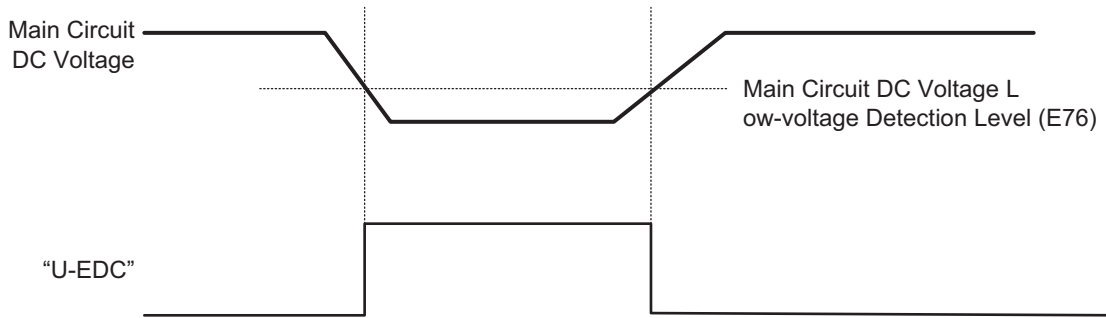

### 7-8-25 AX Terminal Function (AX)

This function is used to control the electromagnetic contactor at the inverter input side in association with the RUN command. It turns ON when the RUN command is input. When the stop command is input, this function turns OFF after the inverter undergoes a deceleration stop. This function turns OFF momentarily when the free run command is input and an alarm is generated.

“AX” can be selected at a capacity of 18.5kW or more of auxiliary power supply.

Connect the power supply directly between R0 and T0.

Parameter No.	Function name	Data	Default data	Unit
E20, E21, E27	Output Terminal [DO1] Function Selection, Output Terminal [DO2] Function Selection, Output Terminal [ROA, ROB] Function Selection	15: Switch MC on the input power lines (for inverter input-side electromagnetic contactor)	-	-

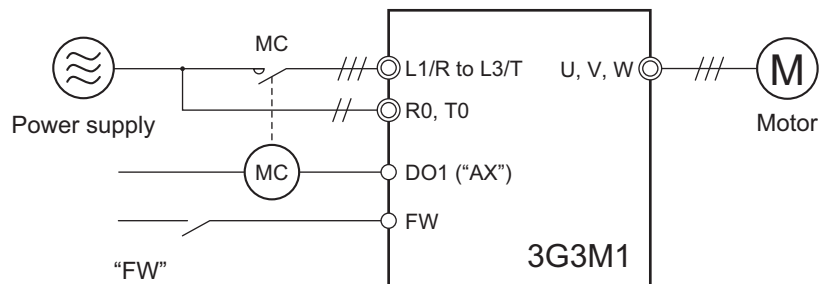

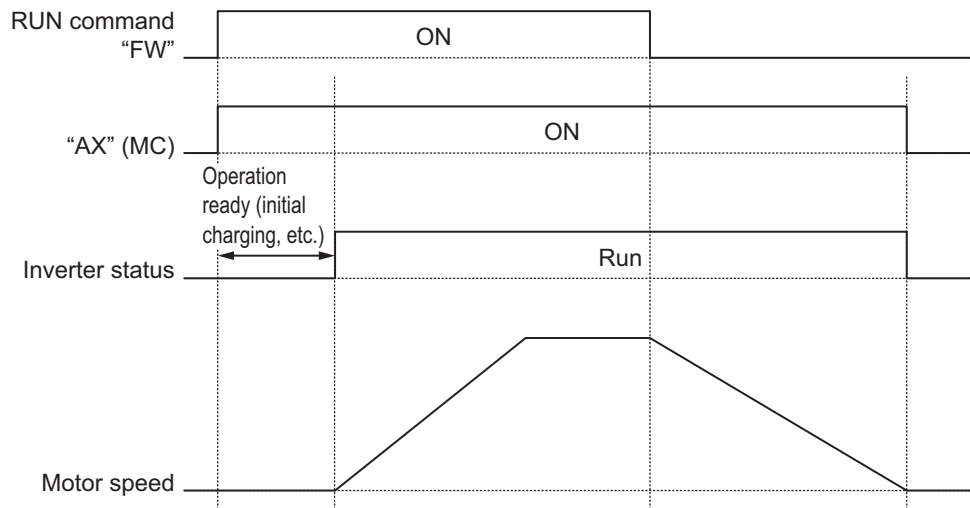

## 7-8-26 Light Alarm Selection

When various error states are detected, this function displays a light alarm (see the codes in the table below) on the LED monitor for light errors, and enables continuation of operation without tripping the inverter. When this is selected, the alarm becomes a minor alarm. The contents of the minor alarm can be selected at Light Alarm Selection 1 (H81)/Light Alarm Selection 2 (H82).

Parameter No.	Function name	Data	Default data	Unit
H81	Light Alarm Selection 1	0 to FFFF	0	-
H82	Light Alarm Selection 2	0 to FFFF	0	-

The causes of the alarm and minor alarm to be selected are as shown below.



### Additional Information

Overheat protection (alarm code: OH1, OH3, OH6) protects by overheat protection (alarm code: OLU) of the inverter that cannot ultimately be turned into a minor alarm. When Motor Electronic Thermal (alarm code: OL1, OL2), Braking Resistor Thermal (alarm code: dbH) and External Alarm (alarm code: OH2) are turned into minor alarms, there is the risk of motors and other external devices burning depending on setting and method of use.

### ● Alarms That Can Be Changed to Minor Alarms

The following alarms can be changed to minor alarms.

Code	Name	Overview
OH1	Cooling fin overheating	The cooling fin temperature has risen to the trip level.
OH2	External trip	An error has occurred in a peripheral equipment, and the external trip "EXT" signal has turned ON.
OH3	Inverter internal overheating	The internal temperature of the inverter has risen abnormally.
OH6	Inrush current prevention resistor overheat	The temperature of the inrush current prevention resistor has risen abnormally due to frequently turning the power supply ON/OFF.



Code	Name	Overview
<i>dbH</i>	Braking resistor overheating	The estimated temperature of the braking resistor coil has risen above the permissible temperature.
<i>OL 1</i> to <i>OL 2</i>	Motor 1, 2 overload	The motor temperature is calculated from the output current of the inverter, and the motor temperature has reached the trip level.
<i>ErP</i>	RS-485 communications error	An error in RS-485 communications
<i>ErE</i>	Speed mismatch (Excessive speed deviation)	The deviation in the speed adjuster (deviation between the speed command and speed estimated value/detected speed) continued for more than the set time (d22) outside the set range (d21).
<i>ErO</i>	Positioning error	During synchronous control, the position deviation exceeded the set value of excessive deviation (10 times of d78).
<i>LoF</i>	Current Input Wire Break Detection	The input terminal [AI2] (AI1) is disconnected.

### ● Minor Alarm Selectable Events

The following events can be set to minor alarms.

Code	Name	Overview
<i>dO</i>	Excessive positioning deviation	The deviation between the current reference position and current feedback position exceeds the detection value
<i>OL</i>	Motor overload early warning	Early warning before the occurrence of motor overload alarm.
<i>OH</i>	Cooling fin overheating early warning	Early warning before the occurrence of cooling fin overheat tripping.
<i>Lf</i>	Lifetime alarm	Any one of the main circuit capacitor used in the inverter, the capacitors on the printed circuit board, and the cooling fan has reached the end of its life.
<i>rEf</i>	Reference loss	The analog frequency reference is disconnected.
<i>PId</i>	PID warning output	Warning related to PID control (Absolute value warning/Deviation warning).
<i>uTl</i>	Low torque detection	The output torque continued to be below the low torque detection level for more than the time set in the timer.
<i>PTC</i>	Motor overheat detected by thermistor (PTC)	Temperature detection by the PTC thermistor of the motor.
<i>rTt</i>	Inverter life (Cumulative operation time of motor)	The cumulative operation time of motor has reached the set maintenance time.
<i>LoT</i>	Inverter life (Number of startups)	The number of startups has reached the set number of maintenance.

## ● Method of selecting light alarm causes

The causes of the light alarm that can be selected are allocated to 0 to 15 bits as shown below, and are set and displayed in hexadecimals.

By setting the bit corresponding to the cause to be selected to 1, the concerned cause can be treated as a light alarm.

### Light Alarm Selection 1 (H81)

Bit	Symbol	Description	Bit	Symbol	Description
15	0H6	Inrush current prevention resistor overheat	7	-	-
14	-	-	6	0L2	Motor 2 overload
13	ErP	RS-485 communications error	5	0L1	Motor 1 overload
12	-	-	4	dbH	Braking resistor overheating
11	-	-	3	-	-
10	-	-	2	0H3	Inverter internal overheating
9	-	-	1	0H2	External trip
8	-	-	0	0H1	Cooling fin overheating

### Light Alarm Selection 2 (H82)

Bit	Symbol	Description	Bit	Symbol	Description
15	-	-	7	Lif	Life warning
14	-	-	6	0H	Cooling fin overheating early warning
13	Inf	Inverter life (Number of startups)	5	0L	Motor overload early warning
12	rIf	Inverter life (Cumulative run time)	4	-	-
11	pTt	Thermistor detection (PTC)	3	LoF	Current input disconnection detection
10	uFl	Low torque detection	2	ErO	Positioning error
9	Pid	PID warning output	1	dB	Excessive Positional Deviation
8	rEf	Reference loss	0	ErE	Speed mismatch (Excessive speed deviation)

(Example) When “RS-485 communications error,” “Motor 1 overload” or “Cooling fin overheating” is selected at H81.

LED No.	LED4				LED3				LED2				LED1			
Bit	15	14	13	12	11	10	9	8	7	6	5	4	3	2	1	0
Symbol	0H6	-	ErP	-	-	-	-	-	-	0L2	0L1	dbH	-	0H3	0H2	0H1

LED No.	LED4	LED3	LED2	LED1
Binary	0 0 1 0	0 0 0 0	0 0 1 0	0 0 0 1
Hexa-decimal	2	0	2	1
Hexa-decimal LED monitor				

The input of light alarm selection must be made by converting a binary 4 bits unit to hexadecimal. The conversion table is shown below.

Binary				Hexadecimal	Binary				Hexadecimal
0	0	0	0	0	1	0	0	0	8
0	0	0	1	1	1	0	0	1	9
0	0	1	0	2	1	0	1	0	A
0	0	1	1	3	1	0	1	1	b
0	1	0	0	4	1	1	0	0	c
0	1	0	1	5	1	1	0	1	d
0	1	1	0	6	1	1	1	0	e
0	1	1	1	7	1	1	1	1	F

### ● Light Alarm L-ALM Signal

If “98: L-ALM (Minor alarm)” is allocated to Output Terminal [DO1] Function Selection (E20), Output Terminal [DO2] Function Selection (E21) and Output Terminal [ROA, ROB] Function Selection (E27), the minor alarm “L-ALM” signal is output when the cause of a minor alarm occurs.

Parameter No.	Function name	Data	Default data	Unit
E20, E21, E27	Output Terminal [DO1] Function Selection, Output Terminal [DO2] Function Selection, Output Terminal [ROA, ROB] Function Selection	98: L-ALM (Minor alarm)	-	-

## 7-8-27 Input Phase Loss Protection / Output Phase Loss Protection

By setting Input Phase Loss Protection Function Selection (H411) and Output Phase Loss Protection Function Selection (H412), it is possible to set whether to continue with the operation or trip the inverter when an input loss or output loss is detected.

Parameter No.	Function name	Data	Default data	Unit
H411	Input Phase Loss Protection Function Selection	0: Disable (Continue to run) 1: Enable (Trip)	1	-
H412	Output Phase Loss Protection Function Selection	0: Disable (Continue to run) 1: Enable (Trip)	0	-

- Input phase loss protection

If excessive stress is generated on the main circuit devices as a result of the loss of the three-phase power supply input to the inverter or the unbalance between phases, it is detected and the input loss protection function (alarm code: Lin) is activated.

If the load to be connected is light and a DC reactor has been connected, the stress on the main circuit devices is low. Therefore, even if there is an input loss or an unbalance between phases, the loss may not be detected.

- Output phase loss protection

If an output loss is detected during the inverter operation, the output loss protection function (alarm code: OPL) is activated.

In a configuration where an electromagnetic contactor is connected at the output side, if the electromagnetic contactor turns OFF during operation, the current of all phases becomes zero. In such a case, the output loss protection function is not activated.

## 7-8-28 Clearing of Integrated Power (KHC)

When this terminal command is turned ON, the integrated power is cleared to zero. Integrating operation is not performed while this terminal command is ON. To resume integrating operation, turn this command OFF.

Parameter No.	Function name	Data	Default data	Unit
E01 to E05, E98, E99	Input Terminal [DI1] to [DI7] Function Selection	164: KHC (Integrated power clear)	-	-

## 7-9 Other Operation Functions

This section describes the parameters associated with other operation functions.

### 7-9-1 Carrier Frequency

Use this function to change the carrier frequency output from the inverter in a PWM waveform.

Set a higher carrier frequency value to reduce the metallic noise from the motor.

However, this results in an increase in electrical noise or leakage current from the inverter.

By setting the level of Motor Sound Tone (F27), it may be possible to reduce the metallic noise generated by the motor. Motor Sound Tone (F27) is enabled if the setting of Carrier Frequency (F26) is 7 kHz or below.

Parameter No.	Function name	Data	Default data	Unit
F26	Carrier Frequency	0: 0.75 kHz 1: 1 kHz 2: 2 kHz 3: 3 kHz 4: 4 kHz 5: 5 kHz 6: 6 kHz 7: 7 kHz 8: 8 kHz 9: 9 kHz 10: 10 kHz 11: 11 kHz 12: 12 kHz 13: 13 kHz 14: 14 kHz 15: 15 kHz 16: 16 kHz	2	-
F27	Motor Sound Tone	0: Level 0 (Disable) 1: Level 1 2: Level 2 3: Level 3	0	
Related function		E165		

- Derating of the output current may be required depending on the installation environment or the setting of Carrier Frequency (F26). For derating in each inverter model, refer to *A-1 Derating Table* on page A-2.

Set the output current value to be derated as electronic thermal level.

This setting, however, is unnecessary if the electronic thermal level is already set to the derating value or lower.

For details on the electronic thermal function, refer to *5-3-3 Motor Electronic Thermal Function* on page 5-20.

- Depending on the motor, the effect of Motor Sound Tone (F27) may be less. If the level of Motor Sound Tone (F27) is increased too much, the output current may become disordered, and the machine vibrations or noise may increase.

## 7-9-2 Automatic Carrier Frequency Reduction

Use this function to reduce the carrier frequency automatically as the output current and the cooling fin temperature increase.

Parameter No.	Function name	Data	Default data	Unit
E165	Carrier Frequency Automatic Reduction Function Selection	0: Disable 1: Enable	1	-
Related function		F26		

- When this function is enabled, overheating or overload trips sometimes can be avoided.

## 7-9-3 Starting Frequency and Stop Frequency

Set the frequency for starting inverter output when the RUN signal is turned ON, and the frequency for stopping the inverter output when the RUN signal is turned OFF.

### Starting Frequency

- During V/f control (Drive Control Selection (F42/A14) = 0, 3)  
When the inverter operation is started, the output frequency starts from the starting frequency. Set the starting frequency to enable securing sufficient starting torque. It is also possible to set the Starting Frequency Holding Time (F24/A62).
- During vector control (Drive Control Selection (F42/A14) = 1, 4, 5, 6, 15, 16)  
When the inverter is started, the speed starts from zero, and acceleration is performed up to the starting frequency in accordance with the set acceleration time and acceleration pattern. After the starting frequency holding time has elapsed, acceleration is again performed to the frequency instructed in accordance with the acceleration time.

Parameter No.	Function name	Data	Default data	Unit
F23	1st Starting Frequency	0.0 to 60.0	0.5	Hz
F24	1st Starting Frequency 1 Holding Time	0.00 to 10.00	0.00	s
A12	2nd Starting Frequency	0.0 to 60.0	0.5	Hz
A62	2nd Starting Frequency Holding Time	0.00 to 10.00	0.00	s

### Stop Frequency

- During V/f control (Drive Control Selection (F42/A14) = 0, 3)  
The inverter output is cut off at the time the output frequency reaches the stop frequency. It is also possible to set the stop frequency (holding time).
- During vector control (Drive Control Selection (F42/A14) = 1, 4, 5, 6, 15, 16)  
The speed detection value/speed estimated value or the speed command reaches the stop frequency, and the stop frequency holding time elapses, and then inverter output is cut off. Select the speed detection value/speed estimated value or the speed command at Stop Frequency Detection Method Selection (F38/A64).

Parameter No.	Function name	Data	Default data	Unit
F25	1st Stop Frequency	0.0 to 60.0 Hz	0.2	Hz
F38	1st Stop Frequency Detection Method Selection	0: Detected/Estimated speed 1: Speed command	0	-
F39	1st Stop Frequency Holding Time	0.00 to 10.00 s	0.00	s
A63	2nd Stop Frequency	0.0 to 60.0	0.2	Hz
A64	2nd Stop Frequency Detection Method Selection	0: Detected/Estimated speed 1: Reference speed	0	-
A65	2nd Stop Frequency Holding Time	0.00 to 10.00 s	0.00	s

● During V/f control (Drive Control Selection (F42/A14) = 0, 3)

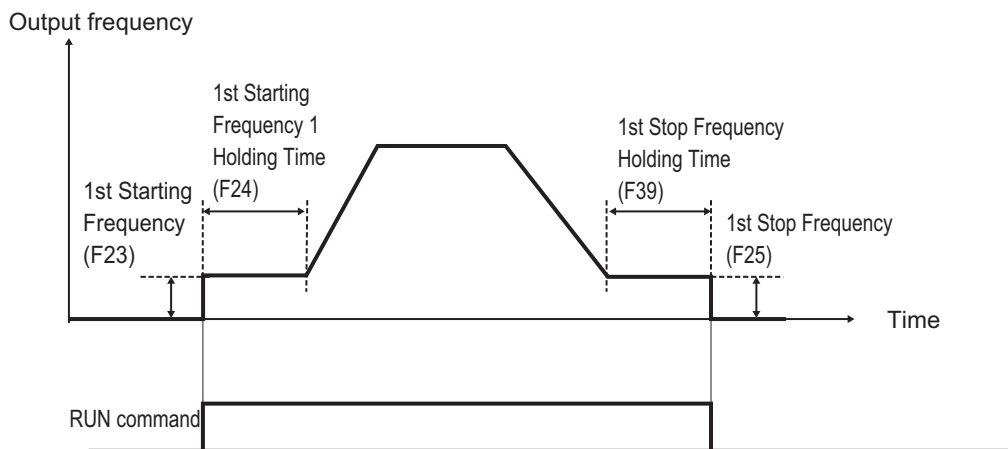

● During vector control (Drive Control Selection (F42/A14) = 1, 4, 5, 6, 15, 16)

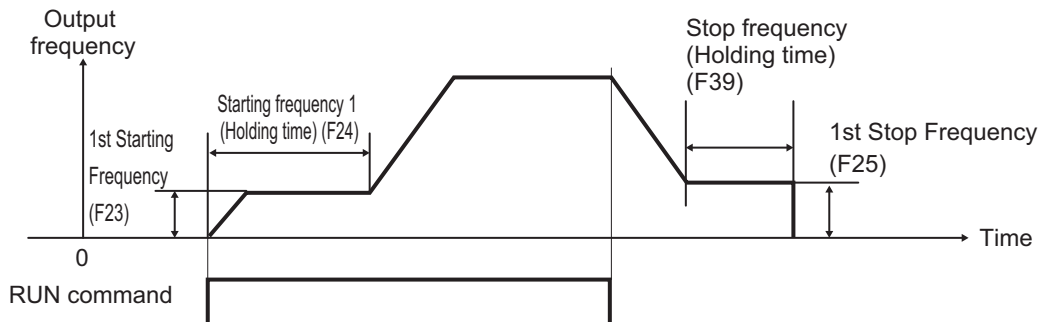

## 7-9-4 Zero Speed Control

Zero speed control keeps the frequency reference motor speed at 0 (zero).

- This is enabled when “5: IM Vector control without speed sensor,” “6: IM Vector control with speed sensor” or “16: PM Vector control with speed and pole position sensor” is set to Drive Control Selection (F42/A14). As this control is enabled only in speed control, set it to ON (speed control) when the speed control/position control switching terminal (137: SPD) is allocated.
- Zero speed control is executed at a startup and stop, and enable/disable is selected at Zero Speed Control (d24).

Parameter No.	Function name	Data	Default data	Unit
d24	Zero Speed Control	0: Disable at startup, enable at stop 1: Enable at startup, enable at stop 2: Disable at startup, disable at stop	0	-
Related function		Drive Control Selection (F42/A14), Starting Frequency (F23/A12), Stop Frequency (F25/A63), Starting Frequency Holding Time (F24/A62), Stop Frequency Holding Time (F39/A65)		

- When zero speed control is enabled, it is executed when the RUN command is ON and the frequency reference is less than the starting frequency and less than the stop frequency. Note, however, that when the starting frequency and stop frequency are 0.0 Hz, zero speed control is executed with the speed command set to 0.00 Hz.
- The following shows the time chart during vector control when “1: Enable at startup, enable at stop” is set to Zero Speed Control (d24). With vector control, acceleration is performed in accordance with the acceleration time up to the starting frequency.

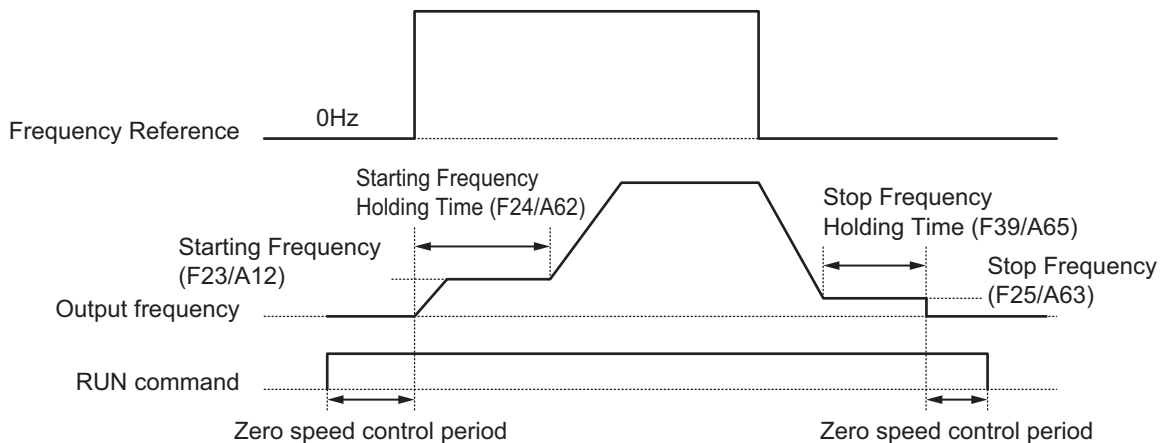

## 7-9-5 Frequency Jump Function

Use this function to avoid the resonant point of the load machine during operation. Three points can be set for the jump frequency range.

Parameter No.	Function name	Data	Default data	Unit
C01/C02/C03	Jump Frequency 1/ Jump Frequency 2/ Jump Frequency 3	0.0 to 590.0 Set the center frequency of the frequency skip width to be jumped.*1	0.0	Hz
C04	Jump Frequency Skip Width	0.0 to 30.0 Set the skip width of the frequency to be jumped.	3.0	Hz

\*1. This function is disabled when 0 Hz is set.

If the jump frequency is set to avoid steady operation within the jump frequency range, the setting of the frequency reference within the jump frequency range operates as described below.



- When the set frequency is increased and the set frequency enters the jump frequency band, the internal set frequency is kept constant at the lower limit of the jump frequency band. If the set frequency exceeds the upper limit of the jump frequency band, the internal set frequency reaches the value of the set frequency. When the set frequency is reduced, the opposite relationship to that during increase is realized.

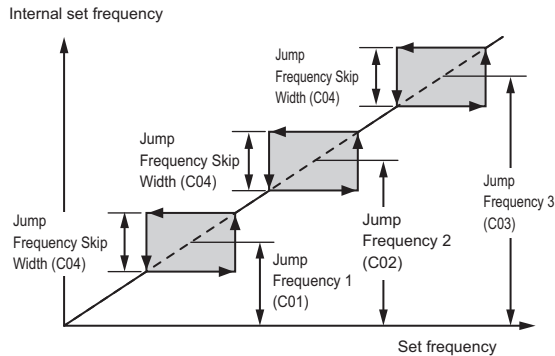

- If two or more jump frequency ranges overlap each other, the lower limit value and the upper limit value of the overlapped jump frequency become the lower limit and upper limit frequencies of the actual jump frequency range.

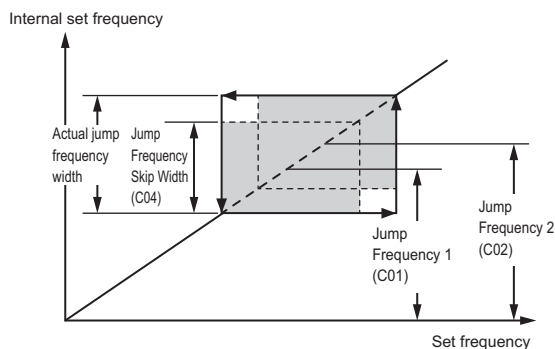

During acceleration and deceleration, the output frequency changes continuously in accordance with the acceleration/deceleration time.

Although the jump frequency can be set at three locations, the jump frequency width is common at the three locations.

## 7-9-6 RUN Direction Limit Selection

This function limits the rotation direction of the motor output.

It can be activated either via the control circuit terminal block or the Digital Operator.

Parameter No.	Function name	Data	Default data	Unit
H08	Reverse Rotation Prevention Function	0: Disable 1: Enable (Reverse rotation inhibited) 2: Enable (Forward rotation inhibited)	0	-

## 7-9-7 Permission of RUN Command

The RUN command is not accepted while the Permission of Run command is OFF.

Parameter No.	Function name	Data	Default data	Unit
E01 to E05, E98, E99	Input Terminal [DI1] to [DI7] Function Selection	38: ROK (Permission of Run command)	-	-

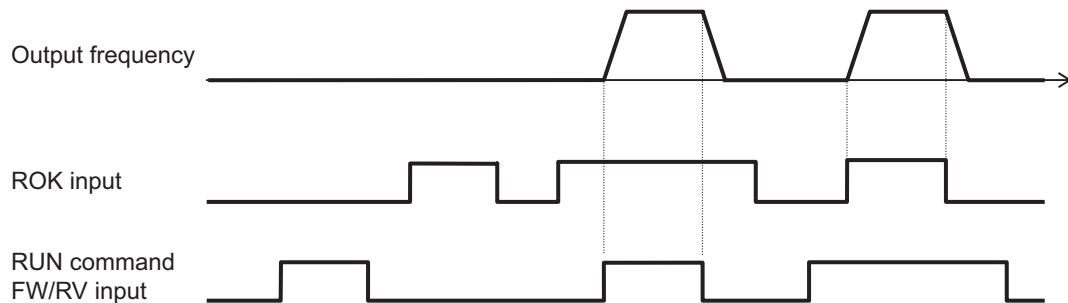

### 7-9-8 Frequency Calculation Function

When “13: Calculation result” is set to Frequency Reference Selection (F01/C30), two frequency references are calculated.

Parameter No.	Function name	Data	Default data	Unit
F01/C30	1st Frequency Reference Selection/2nd Frequency Reference Selection	13: Calculation result	0	-
E131	Frequency Calculation Operation Target 1	0:  or  keys on Operator 1: Voltage input to terminal [AI1] (0 to 10 VDC) 2: Current input to terminal [AI2](AI1) (4(0) to 20 mA DC) 3: Voltage input to terminal [AI2](AIV) (0 to 10 VDC)	1	-
E132	Frequency Calculation Operation Target 2	5: Pulse train input 6: RS-485 (terminal block) 7: Do not set	2	-
E133	Frequency Calculation Operator Selection	0: Addition (E131 + E132) 1: Subtraction (E131 - E132) 2: Multiplication (E131 x E132)	0	-

**Note 1.** The same setting can be made in E131/E132.

**Note 2.** If the calculation results exceed 1st Maximum Output Frequency (F03)/2nd Maximum Output Frequency (A01), the limit is set at the maximum frequency. Similarly, if the calculation results are below 0.0 Hz, the limit is set at 0.0 Hz.

### 7-9-9 Frequency Addition Function

Use this function to add or subtract the value set at Frequency Addition Amount (E134) to or from the selected frequency reference.

If “161: ADD” is not allocated to the multifunction input terminal, or if the ADD terminal is ON, add or subtract E134. If the ADD terminal is turned OFF, the addition or subtraction of Frequency Addition Amount (E134) is canceled, and the inverter returns to the status of the selected frequency reference.

Parameter No.	Function name	Data	Default data	Unit
E134	Frequency Addition Amount	0.00 to 590.0	0.00	Hz
E135	Frequency Addition Sign Selection	0: Frequency command + E134 1: Frequency command - E134	0	-
E01 to E05, E98, E99	Input Terminal [DI1] to [DI7] Function Selection	161: ADD (Frequency addition)	-	-

**Note 1.** If the sign of the frequency reference changes (from (-) to (+), or from (+) to (-)) as a result of the calculation, the rotation direction is reversed.

**Note 2.** When the PID function is used, this function is enabled even for the PID target value. The value is added in increments of 0.01% where the Frequency Addition Amount (E134) with respect to the target PID value is taken to be 100%. At this time, if a value larger than 100.0 is set, the limit is set at 100.0.

## 7-9-10 UP/DOWN control

Use this function to change the inverter output frequency via the multifunction input terminals UP and DWN.

Parameter No.	Function name	Data	Default data	Unit
F01 C30	1st Frequency Reference Selection 2nd Frequency Reference Selection	7: UP/DOWN control	0	-
H61	UP/DOWN Control Initial Value Selection	0: 0.00 Hz 1: Frequency reference when the RUN command is turned OFF	1	-
E01 to E05, E98, E99	Input Terminal [DI1] to [DI7] Function Selection	17: UP (UP/DWN function accelerated) 18: DWN (UP/DWN function decelerated) 58: UDC (UP/DWN function data clear)	-	-

Parameter No.	Function name	Data	Default data	Unit
E43	Operator Display Selection during Run	0 to 32 0: Speed monitor (Selectable with E48) 3: Output current 4: Output voltage 8: Calculated torque 9: Input power 10: PID process command 12: PID feedback 13: Timer value 14: PID output 15: Load factor 16: Motor output 17: Analog signal input monitor 21: Current position 22: Position error 23: Torque current (%) 24: Magnetic flux command (%) 25: Input watt-hour 28: Target position 29: PID deviation 30: Torque bias 32: Reserved	0	-
E44	Operator Display when Stopped Selection	0; 1 0: Specified value 1: Output value	0	-
E48	Operator Display Speed Monitor Item Selection	0 to 7 0: Output frequency 1 (Before slip compensation) 1: Output frequency 2 (After slip compensation) 2: Reference frequency 3: Motor rotation speed 4: Load rotation speed 5: Feed speed 6: Transport time for specified length 7: Speed (%)	0	-

- When the power is ON, the parameter selected at Operator Display when Stopped Selection (E44) is displayed. At the default setting, the output frequency (before slip compensation) is displayed, and initial value "0.00" is displayed flashing. (Refer to 3-1-2 Key Operation Method on page 3-3.)
- When the RUN command is turned ON, the frequency reference when the previous RUN command is OFF is output. To operate from 0 Hz when the RUN command is ON, set UP/DOWN Control Initial Value Selection (H61) to 0.
- Commands from the UP and DWN terminals are enabled only when the RUN command is ON. The frequency reference is added when the UP terminal is ON. The frequency reference is subtracted when the DWN terminal is ON. Addition and subtraction of the frequency reference is stopped when both are ON. When either of the terminals is OFF, the frequency reference is added or subtracted according to the command from the ON terminal.

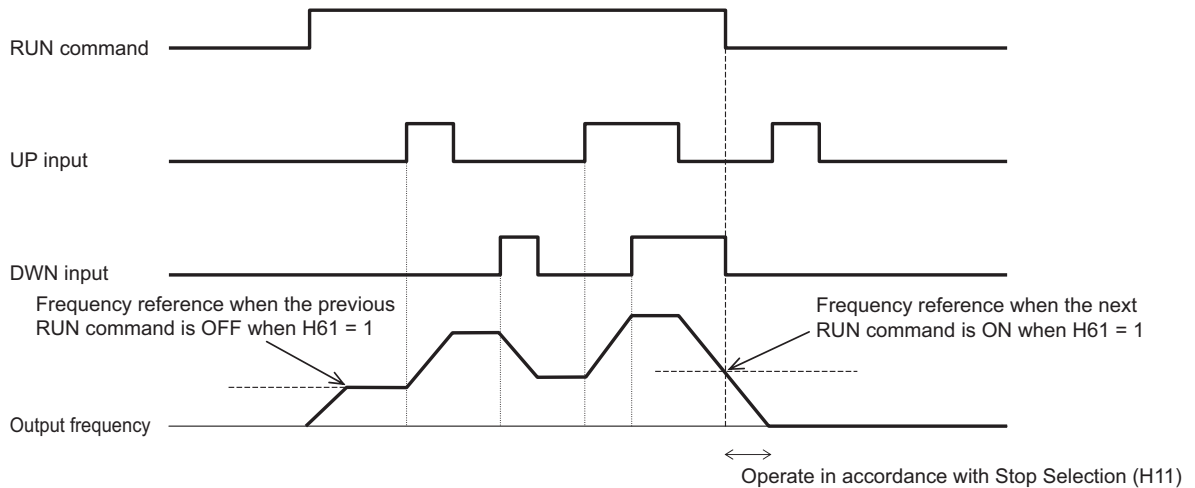

- The frequency reference operates in accordance with the acceleration/deceleration time and acceleration/deceleration pattern (refer to 5-6-2 *Acceleration/Deceleration Pattern* on page 5-40) that is adopted during operation.
- When the UDC terminal turns ON, the frequency reference is set to 0 Hz and a deceleration stop is performed. The UDC terminal is enabled and the frequency reference becomes 0 Hz also when the UP terminal or DWN terminal is ON. When the UDC terminal is turned OFF during a deceleration stop, the frequency reference is operated from 0 Hz in accordance with the UP terminal or DN terminal.

Note) When 0: Other than linear acceleration/deceleration, 1: S-curve acceleration/deceleration, 2: S-curve acceleration/deceleration (Arbitrary) and 3: Curve acceleration/deceleration is selected at Acceleration/Deceleration Pattern Selection (H07), the output frequency changes for a while even if the "UP" terminal and "DWN" terminal are turned OFF.

### 7-9-11 AVR (Automatic Voltage Regulator) Function

This is a function for automatically correcting the output voltage to the motor even if the inverter incoming voltage fluctuates.

This function is used to avoid a drop in the output torque of the motor or the overexcitation state.

Note, however, that the inverter cannot output voltage exceeding the incoming voltage to the inverter.

#### AVR (Automatic Voltage Regulator) Function Setting

The AVR (automatic voltage regulator) function is set to enabled or disabled by 1st AVR Function Selection (E122)/2nd AVR Function Selection (E123).

- The voltage output in the motor is based on the voltage selected at 1st Rated Voltage at Base Frequency (F05)/2nd Rated Voltage at Base Frequency (A03).

Note, however, that the inverter cannot output voltage exceeding the incoming voltage to the inverter.

Parameter No.	Function name	Data	Default data	Unit
E122/E123	1st AVR Function Selection/2nd AVR Function Selection	0: Disable 1: Enable	1	-

Parameter No.	Function name	Data	Default data	Unit
F05/A03	1st Rated Voltage at Base Frequency/2nd Rated Voltage at Base Frequency	80 to 240 V: Output an AVR-controlled voltage (for 200 V class series) 160 to 500 V: Output an AVR-controlled voltage (for 400 V class series)	200	V

## 7-9-12 Overexcitation Control during Deceleration

Overexcitation control during deceleration is a function that decreases the regenerative energy to be fed back to the inverter by forcing the motor during deceleration to be in an overexcited state. It enables you to shorten the deceleration time without use of external braking resistors.

If, in spite of using this function, the operation cannot be performed at the target deceleration time, or if an overcurrent occurs, use the optional braking resistors.

Avoid frequent acceleration and deceleration as it may cause the motor to burn.

This function is enabled in V/f control, V/f control with speed sensor, and vector control with speed sensor. If Anti-regenerative Control Function Selection (H69) in the torque limit method is set to “2: Torque limit control with forced stop after three times deceleration time has passed” or “4: Torque limit control without forced stop,” this function is disabled.

- When using this function, set “1: Enable” to Over-Excitation Control Selection during Deceleration Function Selection (H71).
- By setting Magnetic Flux Level during Deceleration (d90) to higher than 100%, the overexcitation state of the motor is adjusted. Set this as a percentage with the set value of the 1st Rated Voltage at Base Frequency (F05)/2nd Rated Voltage at Base Frequency (A03) as 100%. When 100% is set, this function is disabled regardless of the setting of Over-Excitation Control Selection during Deceleration Function Selection (H71).

Parameter No.	Function name	Data	Default data	Unit
H71	Over-Excitation Control Selection during Deceleration Function Selection	0: Disable 1: Enable	0	-
F05/A03	1st Rated Voltage at Base Frequency/2nd Rated Voltage at Base Frequency	80 to 240 V: Output an AVR-controlled voltage (for 200 V class series) 160 to 500 V: Output an AVR-controlled voltage (for 400 V class series)	200	V
d90	Magnetic Flux Level during Deceleration	100 to 300 %	120	%
Related function		H69		

- Adjusting overexcitation control during deceleration  
Set Over-Excitation Control Selection during Deceleration Function Selection (H71) to “1: Enable,” and gradually keep increasing the set data of Magnetic Flux Level during Deceleration (d90) so as to approach the desired deceleration time. If, in spite of using this function, the operation cannot be performed at the target deceleration time, or if an overcurrent occurs, use the external braking resistors.

## 7-9-13 PID Function



PID control detects the status (control amount) of the object to be controlled by a sensor, etc., and compares it with the target value (such as the temperature command). If there is a deviation during this time, operation is performed to set the deviation to zero. It is a closed loop control method that matches the control amount (feedback value) with the target value.

It is possible to perform process controls such as the flow rate control, pressure control, temperature control, etc., and speed controls such as the dancer control.

If PID control is enabled (PID Control Function Selection (J01) = 1 to 5), the frequency setting block switches to PID control block.

The PID function is disabled in the case of the torque control (refer to 6-6 *Torque Control* on page 6-31) and the position control (refer to 6-7 *Position Control* on page 6-36).

Parameter No.	Function name	Data	Default data	Unit
E119	PID Control Feedback Selection	0: Analog input terminals (AI1, AI2 (All function), AI2 (AIV function)) 2: Modbus communication 3: Pulse train frequency	0	-
E120	PID Control PID Output Variable Range for Process Control	0.0: Function disabled 0.1 to 100.0: Variable range based on target value	0	-
E121	PID Control PID Feedforward Selection for Process Control	0: Disable 1: Analog input terminals AI1, AI2 (All), AI2 (AIV)	0	-
C59	Input Terminal [AI1] Analog Input Adjustment Maximum Scale	-999.00 to 0.00 to 9,990.00	100	-
C60	Input Terminal [AI1] Analog Input Adjustment Minimum Scale	-999.00 to 0.00 to 9,990.00	0	-
C65	Input Terminal [AI2] Analog Input Adjustment Maximum Scale (All)	-999.00 to 0.00 to 9990.00	100	-
C66	Input Terminal [AI2] Analog Input Adjustment Minimum Scale (All)	-999.00 to 0.00 to 9990.00	0	-
C71	Input Terminal [AI2] Analog Input Adjustment Maximum Scale (AIV)	-999.00 to 0.00 to 9990.00	100	-
C72	Input Terminal [AI2] Analog Input Adjustment Minimum Scale (AIV)	-999.00 to 0.00 to 9990.00	0	-
J01	PID Control Function Selection	0: Disable 1: Process normal operation 2: Process (inverse operation) 3: Speed control (Dancer) 4: Process (normal operation, opposite operation available) 5: Process (inverse operation, opposite operation available)	0	-

Parameter No.	Function name	Data	Default data	Unit
J02	PID Control PID Command Selection	0:  or  keys on Operator 1: PID process command 1 (Analog input terminals AI1, AI2(AII), AI2(AIV)) 3: Terminal command UP / DWN control 4: Communication	0	-
J03	PID Control P Proportional Gain	0.000 to 30.000	0.1	time
J04	PID Control I Integral Time	0.0 to 3600.0	0	s
J05	PID Control D Differential Time	0.00 to 600.00	0	s
J06	PID Control Feedback Filter	0.0 to 900.0	0.5	s
J10	PID Control Anti-reset Windup Width	0 to 200	200	%
J11	PID Control Select Warning Output Selection	0: Warning from absolute value 1: Warning from absolute value with hold 2: Warning from absolute value with latch 3: Warning from absolute value with hold and latch 4: Warning from PID error 5: Warning from PID error with hold 6: Warning from PID error with latch 7: Warning from PID error with hold and latch	0	-
J12	PID Control Upper Limit of Warning (AH)	-100 to 100	100	%
J13	PID Control Lower Limit of Warning (AL)	-100 to 100	0	%
J15	PID Control Sleep Frequency for Process Control	0.0: Disable 1.0 to 590.0	0	Hz
J16	PID Control Sleep Timer for Process Control	0 to 60	30	s
J17	PID Control Restart Frequency after Stopping for Process Control	0.0 to 590.0	0	Hz
J18	PID Control PID Output Upper Limit	-150 to 150 999: Depends on setting of F15	999	%
J19	PID Control PID Output Lower Limit	-150 to 150 999: Depends on setting of F16	999	%
J23	PID Control Restart Feedback Deviation after Stopping for Process Control	0.0 to 100.0	0	%
J24	PID Control Restart Delay Time after Stopping for Process Control	0 to 3600	0	s
J57	PID Control Operator PID Reference Position for Dancer	-100 to 0 to 100	0	%



Parameter No.	Function name	Data	Default data	Unit
J58	PID Control PID Reference Position Detection Width for Dancer	0: Disable switching PID constant 1 to 100	0	%
J59	PID Control P Gain 2	0.000 to 30.000	0.1	time
J60	PID Control I Integral Time 2	0.0 to 3600.0	0	s
J61	PID Control D Differential Time 2	0.00 to 600.00	0	s
J62	PID Control Block Selection	0 to 3 bit 0: Select polarity compensation for PID output/error 0 = Plus (Addition) 1 = Minus (Subtraction) bit 1: Select compensation factor for PID output 0 = Ratio (relative to the main setting) 1 = Speed command (relative to maximum frequency)	0	-
J106	PID Control Maximum Scale	-999.00 to 0.00 to 9990.00	100	-
J107	PID Control Minimum Scale	-999.00 to 0.00 to 9990.00	0	-
J136	PID Control Multistep PID Command 1	-999.00 to 0.00 to 9990.00	0	-
J137	PID Control Multistep PID Command 2	-999.00 to 0.00 to 9990.00	0	-
J138	PID Control Multistep PID Command 3	-999.00 to 0.00 to 9990.00	0	-
H438	Feedback Value Comparison Signal Off Level	0.0 to 100.0 FBV signal output judgment level	100	%
H439	Feedback Value Comparison Signal On Level	0.0 to 100.0 FBV signal output judgment level	0	%
S13 *1	PID Control PID Command via Communication	-32,768 to 32,767 -20,000 = -100%, 20,000 = 100%	0	-
S30 *1	PID Control Feedback Value via Communication	-32,768 to 32,767 -20,000 = -100%, 20,000 = 100%	0	-
M73 *1	PID Output Monitor	-32,768 to 32,767 -20,000 = -100%, 20,000 = 100%	0	-
M115 *1	PID Output Non Filter	-150.0 to 150.0	0	%
W11	PID Process Command	-999.00 to 0.00 to 9990.00	0	-
W12	PID Feedback Value Monitor	-999.00 to 0.00 to 9990.00	0	-
W29 *1	Frequency and PID Command Source Monitor	0 to 25, 39: Command source No. other than PID control 30: PID control Touch panel process 31: PID Control Analog Process 33: PID Control UP/DOWN control 34: PID Control Communication Process 36: PID Control Multi-Step Terminal Process	0	-
W32	PID Output Monitor	-150.0 to 150.0	0	%
W131 *1	PID Control PID Deviation (After Scale Transformation)	-999.00 to 0.00 to 9990.00	0	-

Parameter No.	Function name	Data	Default data	Unit
W132 *1	PID Control PID Deviation (No Scale Transformation)	-32768 to 32767 -20000 = -100% +20000 = +100%	0	-
E01 to E05, E98, E99	Input Terminal [DI1] to [DI7] Function Selection	20: PID (PID control cancellation) 21: IVS (Normal/Inverse switching) 33: PID-RST (Switch normal/inverse operation) 34: PID-HLD (Hold PID integral component hold) 171: PID-SS1 (PID control multistage command 1) 172: PID-SS2 (PID control multistage command 2)	-	-
E20, E21, E27	Output Terminal [DO1] Function Selection, Output Terminal [DO2] Function Selection, Output Terminal [ROA, ROB] Function Selection	42: OD (Excessive PID deviation) 43: PID-CTL (Under PID control) 44: PID-STP (Under sleep mode of PID control)*2 186: FBV (PID FB status output)	-	-
E61, E62, E63	Input Terminal [AI2] Function Selection (AII) (E62)/Input Terminal [AI2] Function Selection (AIV) (E63)	21 : PID feed forward	-	-
Related function		Output Terminal [DO1] ON Delay Time (H309) Output Terminal [DO2] ON Delay Time (H311) Output Terminal [ROA, ROB] ON Delay Time (H313) Output Terminal [DO1] OFF Delay Time (H310) Output Terminal [DO2] OFF Delay Time (H312) Output Terminal [ROA, ROB] OFF Delay Time (H314)		

\*1. It can be referenced or set only from the communications function or Sysmac Studio.

\*2. The OFF delay of the Under sleep mode of PID control (44: PID-STP) terminal becomes the time obtained by adding 0.1 s to Output Terminal [DO1] OFF Delay Time (H310), Output Terminal [DO2] OFF Delay Time (H312) and Output Terminal [ROA, ROB] OFF Delay Time (H314).

## PID Control Function Selection

PID control is enabled by setting other than 0 to PID Control Function Selection (J01).

- PID Control Function Selection (J01) = "1: Process normal operation," "2: Process inverse operation"

If the PID process control is performed and PID calculation results are negative, the frequency reference to the inverter is limited at 0 Hz.

- PID Control Function Selection (J01) = "4: Process normal operation, opposite operation available," "5: Process inverse operation, opposite operation available"

If the PID process control is performed and PID calculation results are negative, an opposite operation can be performed for the inverter. PID Control PID Output Variable Range for Process Control (E120) is disabled.

- PID Control Function Selection (J01) = "3: Dancer"

PID dancer control is performed. Opposite operation can be done for dancer control.

### ● Schematic block diagram of PID process control

When PID Control Function Selection (J01) = "1," "2," "4," "5"

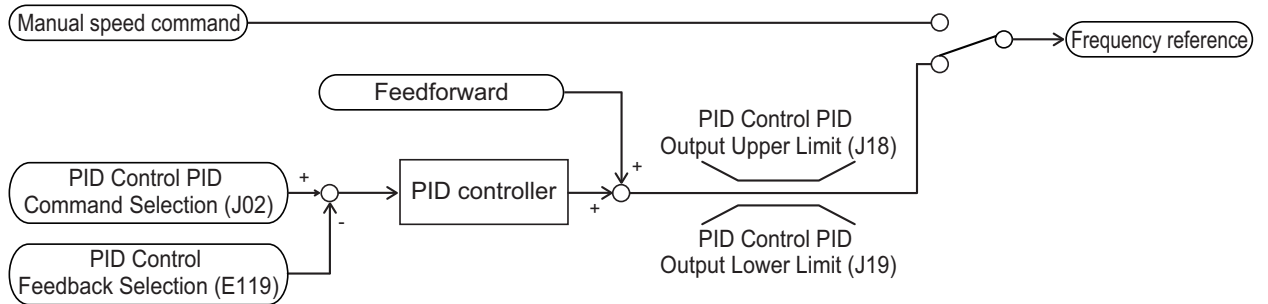

### ● Schematic block diagram of PID dancer control

When PID Control Function Selection (J01) = "3"

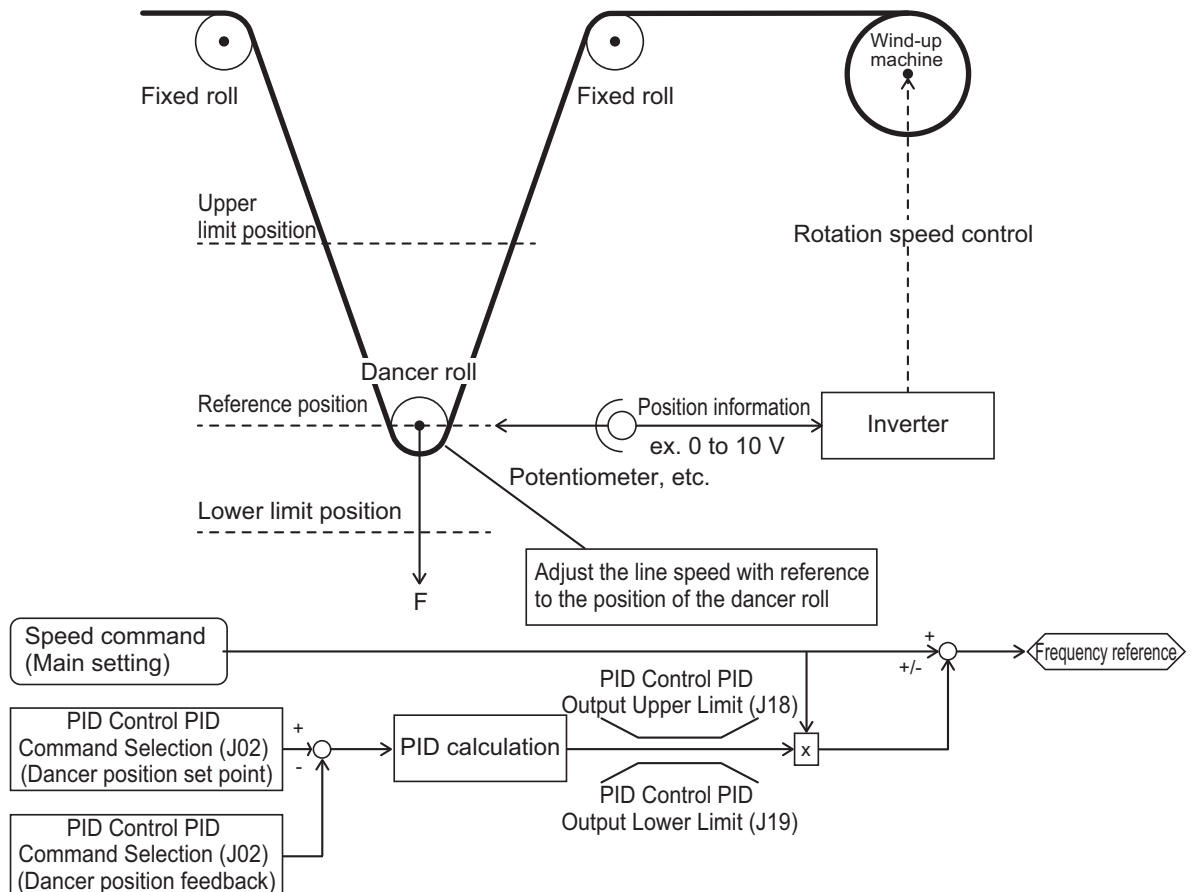

## PID Operation

#### 1. PID Control P Proportional Gain (J03)

In this operation, the operation amount is proportional to the deviation (difference between the target value and the current value).



2. PID Control I Integral Time (J04)

In this operation, the operation amount is proportional to the time integral value of the deviation. The P operation is less effective as the current value approaches the target value due to smaller deviation, taking a long time to reach the target value. The I operation compensates this disadvantage.

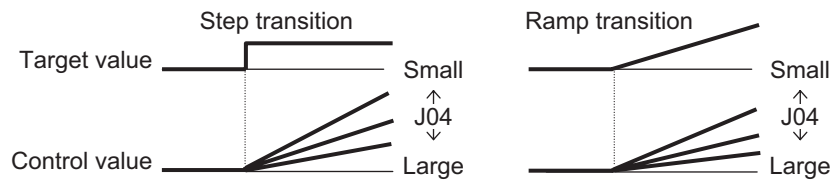

3. PID Control D Differential Time (J05)

In this operation, the operation amount is proportional to the percentage of change in the deviation. Because using only the PI operation is time-consuming, the D operation is used to effectively compensate for the disadvantage in responsiveness.

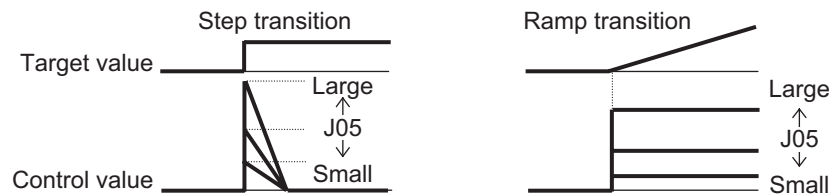



## PID Normal Operation/Reverse Operation

Since normal operation or reverse operation can be selected for the output of PID process control, the fluctuations in the motor rotation speed with respect to the deviation (difference between the command value and feedback value) can be set. Switching of normal operation and reverse operation by an external signal (21:IVS (Switch normal/inverse operation)) is also possible.



## PID command

This command is used to select the means for setting the command values of PID control.

J02	Function
0	PID command by Operator PID command by the  /  keys on Operator

J02	Function
1	PID command 1 (Analog input: Terminals [AI1], [AI2] (All function), [AI2] (AIV function)) Setting based on the voltage value (0 to ±10 VDC, PID 100% command/±10 VDC) input to the terminal [AI1]. Setting based on the current value (4 to 20 mA DC, PID 100% command/20 mA DC) input to the terminal [AI2] (All function). Setting based on the voltage value (0 to 10 VDC, PID 100% command/10 VDC) input to the terminal [AI2] (AIV function).
3	PID command by the UP/DOWN commands With the UP command "UP" and the DOWN command "DOWN," the PID control commands 0% to 100% can be set to a value obtained by conversion to a physical quantity by PID Control Minimum Scale (J107) and PID Control Maximum Scale (J106).
4	Command by communication Communication parameter (S13): Transmission data 20000d/100% PID command

- PID command by Operator (J02 = 0 (Factory default state))

With the  /  keys on the Operator, the PID control commands 0% to 100% (±100% during dancer control) can be set to a value obtained by conversion to an easy-to-identify display such as physical quantity by PID Control Maximum Scale (J106) and PID Control Minimum Scale (J107).

- PID command 1 by analog input (J02 = 1)  
The PID command value can be set arbitrarily by multiplying the gain with the PID command value based on analog input (the voltage value input to the terminal [AI1] and terminal [AI2] (AIV function), and the current value input to the terminal [AI2] (All function)), and then adding the bias. Polarity selection, filtering and offset adjustment are also possible. In addition to setting of J02, PID command 1 must be selected for each analog setting (parameters E61, E62 and E63) as well.
- PID command by UP/DOWN control (J02 = 3)  
If UP/DOWN control is selected as the PID control command, and either "UP" or "DWN" is turned ON, the command value of PID control fluctuates in the range of maximum scale to minimum scale accordingly.

To make the setting of the PID command by UP/DOWN control, it is necessary to allocate "17: UP (UP/DWN function accelerated)" or "18: DWN (UP/DWN function decelerated)" to the input terminals [DI1] to [DI7].

UP	DWN	Operation
OFF	OFF	The current command values of PID control are retained.
ON	OFF	The command values of PID control increase according to the change rate from 0.1%/0.1 s to 1%/0.1 s.
OFF	ON	The command values of PID control decrease according to the change rate from 0.1%/0.1 s to 1%/0.1 s.
ON	ON	The current command values of PID control are retained.

In the inverter, the PID control values set by the UP/DOWN control are maintained internally, and when the operation is resumed (including when the power is turned ON), the control is started from the previous PID command value.

When analog input is applied to the PID command value, the following gains, biases, filters and offsets are applicable.

Input terminal	Input range	Bias		Gain		Polarity selection (Range selection)	Filter	Offset
		Bias	Base point	Gain	Base point			
AI1	0 to 10 V -10 to 10 V	C55	C56	C32	C34	C35	C33	C31
AI2 (All function)	4 to 20 mA, 0 to 20 mA	C61	C62	C37	C39	C40	C38	C36
AI2 (AIV function)	0 to +10 V	C67	C68	C42	C44	C45	C43	C41

The following processing is performed during polarity selection C35, C45 and range selection C40.

C35: Set the input range of the AI1 terminal.

C35	Terminal input specifications
0	-10 to 10 V
1	0 to 10 V (A negative voltage is considered as 0 V.)

C40: Set the input range of the AI2 (All function) terminal.

C40	Terminal input specifications	Handling when the bias value is set as a negative value
0	4 to 20 mA	0 is set as the limit for a value below 0.
1	0 to 20 mA	
10	4 to 20 mA	A value below 0 is enabled as a negative value.
11	0 to 20 mA	

C35: Set the input range of the AI2 (AIV function) terminal.

C35	Terminal input specifications	Handling when the bias value is set as a negative value
0	0 to +10 V	A value below 0 is enabled as a negative value.
1	0 to +10 V	0 is set as the limit for a value below 0.

An example of PID process control is shown below.

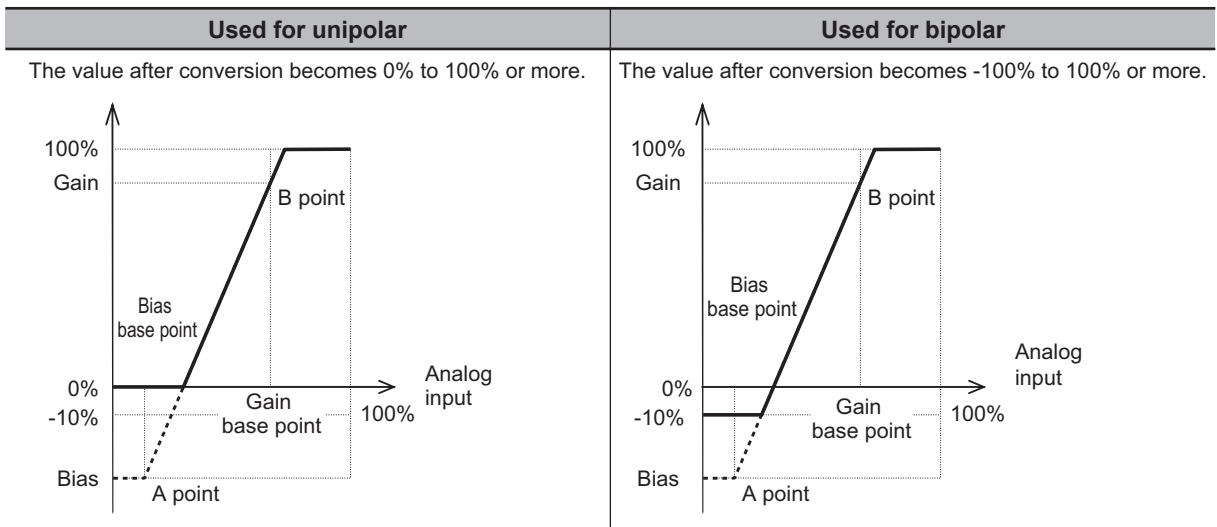

An example of dancer control is shown below.

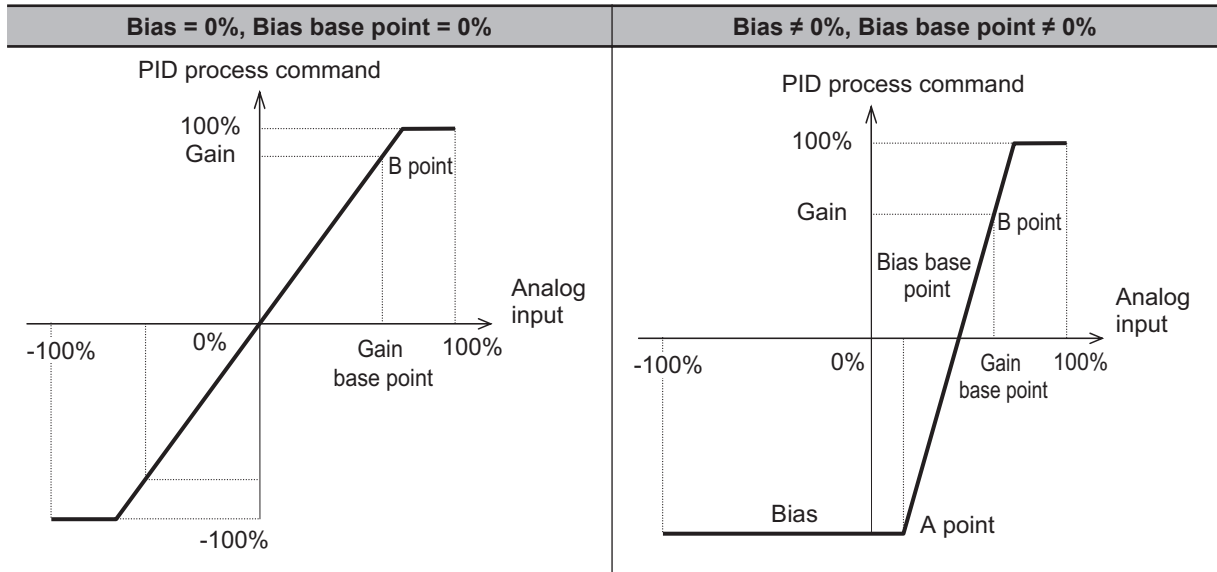

- PID command by communication (J02 = 4)  
Communication parameter (S13): Transmission data 20000d/100% PID command.

## PID Control Feedback Selection (E119)

- E119 = 0: Analog input terminal  
If 0: Analog input terminal ([AI1], [AI2] All function, [AI2] AIV function) is selected for PID Control Feedback Selection (E119), allocate “5: PID feedback value” to the terminal used in feedback input by any one of E61, E62 or E63. The analog input value is internally controlled as 0% to 100%. For details on analog input, refer to 7-3-1 Analog Input Function Selection on page 7-35.

When analog input is applied to PID feedback, the following gains, biases, filters and offsets are applicable.

Input terminal	Input range	Bias		Gain		Polarity selection (Range selection)	Filter	Offset
		Bias	Base point	Gain	Base point			
AI1	0 to 10 V, -10 to 10 V	C55	C56	C32	C34	C35	C33	C31
AI2 (All function)	4 to 20 mA, 0 to 20 mA	C61	C62	C37	C39	C40	C38	C36
AI2 (AIV function)	0 to +10 V	C67	C68	C42	C44	C45	C43	C41

- E119 = 2: Modbus communication  
If “2: Modbus communication” is set to PID Control Feedback Selection (E119), set a value in communication parameter (S30) under the assumption of 20000d = 100%.
- E119 = 3: Pulse train frequency  
If “03: Pulse train frequency” is set to PID Control Feedback Selection (E119), the inverter captures a value converted into a percentage with the maximum frequency as 100% where the correction factor (d63/d62) is multiplied with the frequency value [kP/s] of the captured pulse train input.

$$f^* [\text{Hz}] = N_p [\text{kp/S}] \times \frac{\text{Input Terminal [PIA][PIB] Pulse Scaling Factor Numerator (d17)}}{\text{Input Terminal [PIA][PIB] Pulse Scaling Factor Denominator (d16)}}$$

$$\text{PV} [\%] = f^* [\text{Hz}] \times \frac{100}{\text{Maximum frequency} [\text{Hz}]}$$

PV [%]: PID feedback input

$f^*$  [Hz]: Frequency set value

$N_p$  [kp/s]: Entered input pulse frequency

## Feedforward Selection

Feedforward is applied during PID process control. Select at PID Control PID Feedforward Selection for Process Control (E121). If “1: Analog input terminal” is selected, allocate “21: PID feed forward value” to either of Input Terminal [AI1] Function Selection (E61), Input Terminal [AI2] Function Selection (AI1) (E62) or Input Terminal [AI2] Function Selection (AIV) (E63). If not allocated, feedforward control is not performed.

Feedforward is disabled during dancer control.

## PID Variable Range

In the case of PID process control, the PID output is restricted to a variable range with reference to the target value.

When using this function, set PID Control PID Output Variable Range for Process Control (E120).

Then, the output frequency will be limited to within a range of Target value  $\pm$  (E120) with the maximum frequency as 100%.

If E120 is 0.0, the function is disabled. The function is also disabled when “4: Process normal operation, opposite operation available” or “5: Process inverse operation, opposite operation available” is set to PID Control Function Selection (J01).

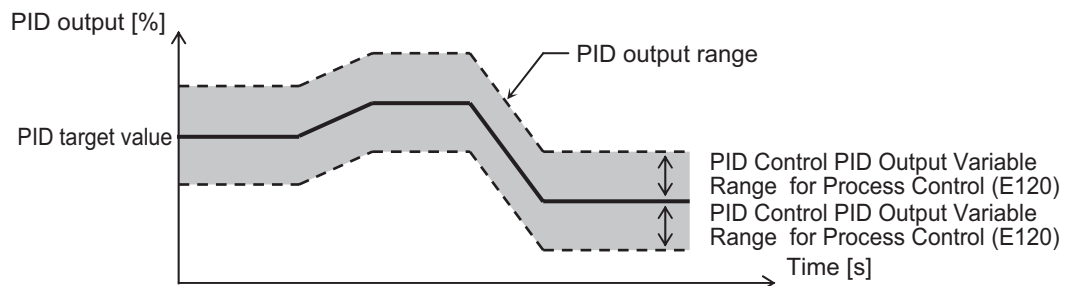

## PID Reverse Output

If the PID calculation results are negative during regular PID control (J01 = 1, 2), the frequency reference to the inverter is limited at 0 Hz. If PID Control Function Selection (J01) is set to “4: Process normal operation, opposite operation available” or “5: Process inverse operation, opposite operation available,” an inverse output can be performed for the inverter if the PID calculation results are negative.



If 4 or 5 is set to PID Control Function Selection (J01), PID Control PID Output Variable Range for Process Control (E120) is disabled.

## PID Gain Adjustment

If the PID function does not provide a stable response, adjust each gain as described below depending on the state.

State	Adjustment method
Changes in target value are not reflected quickly on feedback value.	Increase PID P Gain J03
Changes are reflected quickly on feedback value, but not stable.	Decrease PID P Gain J03
Target and feedback values do not match quickly.	Decrease I Gain J04
Feedback value fluctuates unstably.	Increase PID I Gain J04
Increasing PID P Gain does not improve response speed.	Increase PID D Gain J05
Increasing PID P Gain results in fluctuating and unstable feedback value.	Decrease PID D Gain J05

## PID Deviation Excessive (OD)

An absolute value warning or a deviation warning can be output in PID control. As a warning output, allocate "42: OD (Excessive PID deviation)" to Output Terminal [DO1] Function Selection (E20), Output Terminal [DO2] Function Selection (E21) and Output Terminal [ROA, ROB] Function Selection (E27). At PID Control Select Warning Output Selection (J11), set the warning type, and at PID Control Upper Limit of Warning (AH) (J12) and PID Control Lower Limit of Warning (AL) (J13), set the upper limit value and lower limit value of the warning, respectively.

J11	Type	Description
0	Warning caused by process command value	<p>"OD" is ON when <math>PV &lt; AL</math> or <math>AH &lt; PV</math></p> <p>PID feedback value (PV)</p> <p>PID Control Lower Limit of Warning (AL) (J13)</p> <p>PID Control Upper Limit of Warning (AH) (J12)</p>
1	Warning from absolute value with hold	Same as above (with hold)
2	Warning from absolute value with latch	Same as above (with latch)
3	Warning from absolute value with hold and latch	Same as above (with hold and latch)
4	Warning caused by PID error value	<p>"OD" is ON when <math>PV &lt; SV-AL</math>, <math>SV+AH &lt; PV</math></p> <p>PID feedback value (PV)</p> <p>PID process command (SV)</p> <p>PID Control Lower Limit of Warning (AL) (J13)</p> <p>PID Control Upper Limit of Warning (AH) (J12)</p>
5	Warning from PID error with hold	Same as above (with hold)
6	Warning from PID error with latch	Same as above (with latch)
7	Warning from PID error with hold and latch	Same as above (with hold and latch)

- Hold function : When the power is turned ON, the warning output turns OFF even within the warning range. The warning output is enabled when it goes outside the warning range and then again enters the warning range.
- Touch probe function : Once the warning output turns ON after entering the warning range, the warning output does not turn OFF even if it goes outside the range. To release the latch, either press the  key on the Operator, or turn ON the RS allocated to the multifunction input terminal.

- The OD terminal has an OFF delay of 0.1 s. The final OFF delay time becomes the time obtained by adding 0.1 s to Output Terminal [DO1] OFF Delay Time (H310), Output Terminal [DO2] OFF Delay Time (H312) and Output Terminal [ROA, ROB] OFF Delay Time (H314).

## Feedback Comparison Signal

If PID feedback is outside the setting range, the signal is output to the multifunction output terminal. To output this signal, allocate “186: FBV (PID FB status output)” to Output Terminal [DO1] Function Selection (E20), Output Terminal [DO2] Function Selection (E21) and Output Terminal [ROA, ROB] Function Selection (E27).

Set Feedback Value Comparison Signal Off Level (H438)/Feedback Value Comparison Signal On Level (H439) in units of percentage with 1st Maximum Output Frequency (F03)/2nd Maximum Output Frequency (A01) as 100%.

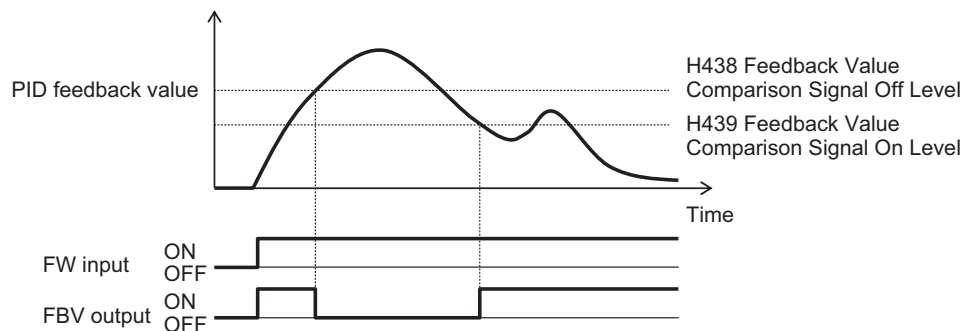

## PID Feedback Value Monitor (Monitor Mode: 3\_11)

The PID feedback value is converted to the control-target physical quantity (such as the temperature, pressure, etc.) using the data of PID Control Maximum Scale (J106) and PID Control Minimum Scale (J107).

Display value = (PID feedback value (%)/100) × (Maximum scale - Minimum scale) + Minimum scale  
If PID control is disabled, “----” is displayed.

## PID Integral Reset (PIDC)

Use this function to clear the integral value of PID operation.

To output this signal, allocate “33: PIDC (PID integral reset)” to Output Terminal [DO1] Function Selection (E20), Output Terminal [DO2] Function Selection (E21) and Output Terminal [ROA, ROB] Function Selection (E27).

The values are cleared each time the PIDC terminal is turned ON.

Never turn ON the PIDC terminal during the PID operation as overcurrent tripping may occur. Be sure to deactivate the PID operation before turning ON the PIDC terminal.

## PID Sleep Function

In parameters J15 to J17, J23, J24, a sleep function for stopping the inverter when the discharge pressure rises and the discharge volume reduces during pump control is set. When the discharge pressure rises, the frequency set value of the output of PID controller drops, and the PID Control Sleep Timer for Process Control (J16) elapses at the PID Control Sleep Frequency for Process Control (J15) or below, the inverter decelerates and stops. However, PID control itself continues. When the discharge pressure falls, the frequency set value of the output of PID controller rises, and the PID Control Restart Frequency after Stopping for Process Control (J17) is exceeded, the inverter resumes operation. The restart conditions can be adjusted by PID Control Restart Feedback Deviation after Stopping for Process Control (J23) and PID Control Restart Delay Time after Stopping for Process Control (J24) based on the time and pressure variation.

- PID Control Sleep Frequency for Process Control (J15)  
The sleep frequency is set.
- PID Control Sleep Timer for Process Control (J16)  
The time from when the PID output falls below the value set in J15 until the inverter starts deceleration stop is set.
- PID Control Restart Frequency after Stopping for Process Control (J17)  
The wakeup frequency is set. Set the wakeup frequency larger than the sleep frequency (J15). If the wakeup frequency is set smaller than the sleep frequency, the sleep frequency is ignored, and the sleep function operates when the PID output falls below the wakeup frequency set value.
- Under sleep mode of PID control "PID-STP" (Parameter E20 to E21, E27 data = 44)  
Under sleep mode of PID control "PID-STP" outputs an ON signal when the inverter stops by the sleep function during PID control. If a signal output indicating that the inverter is in a stopped state is required, it is necessary to allocate "PID-STP."

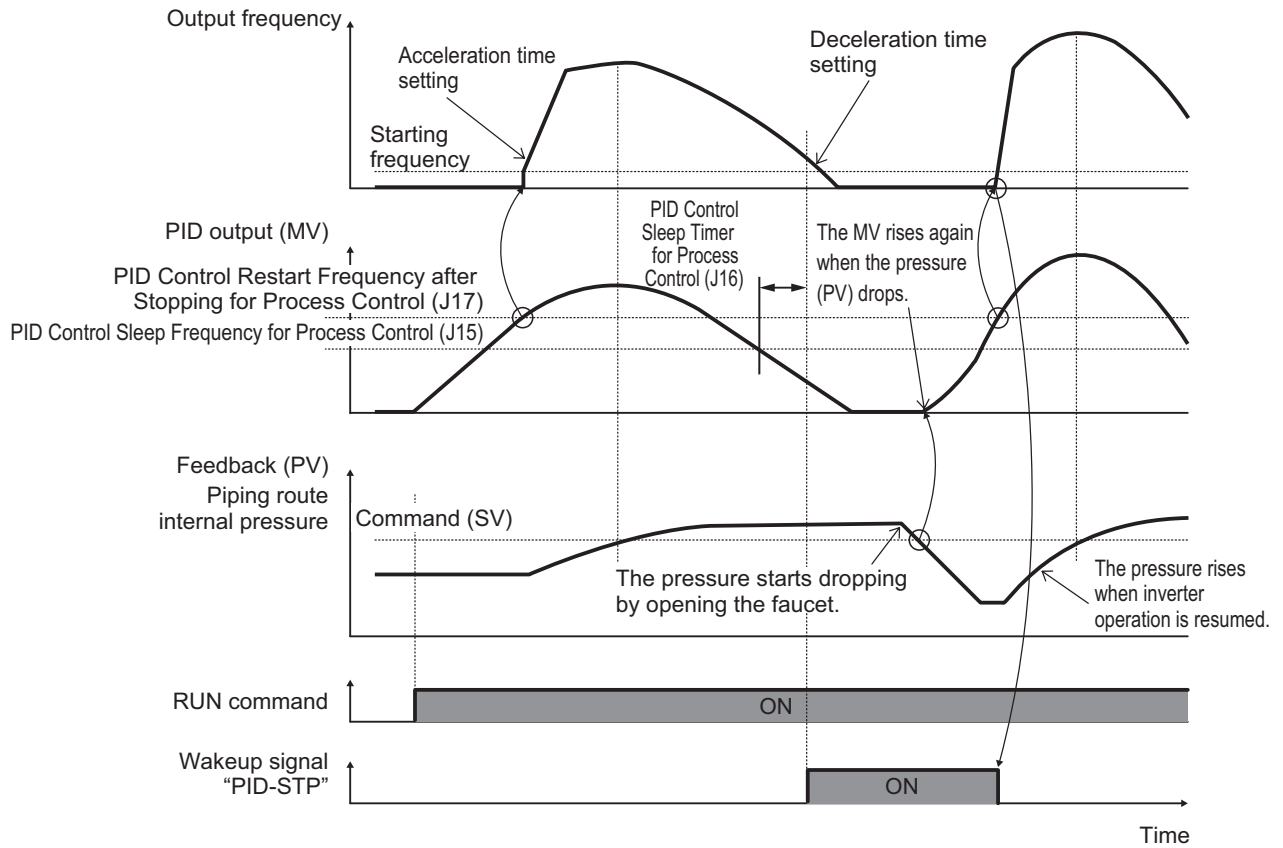

- PID Control Restart Feedback Deviation after Stopping for Process Control (J23)
- PID Control Restart Delay Time after Stopping for Process Control (J24)

The inverter restarts when both of the following conditions are satisfied.

1. The discharge pressure falls, the frequency reference value of the PID controller output rises, the Restart Frequency (J17) is exceeded, and the PID Control Restart Delay Time after Stopping for Process Control (J24) elapses.
2. The difference between SV (command value) and PV (feedback value) becomes more than PID Control Restart Feedback Deviation after Stopping for Process Control (J23), and the PID Control Restart Delay Time after Stopping for Process Control (J24) elapses.

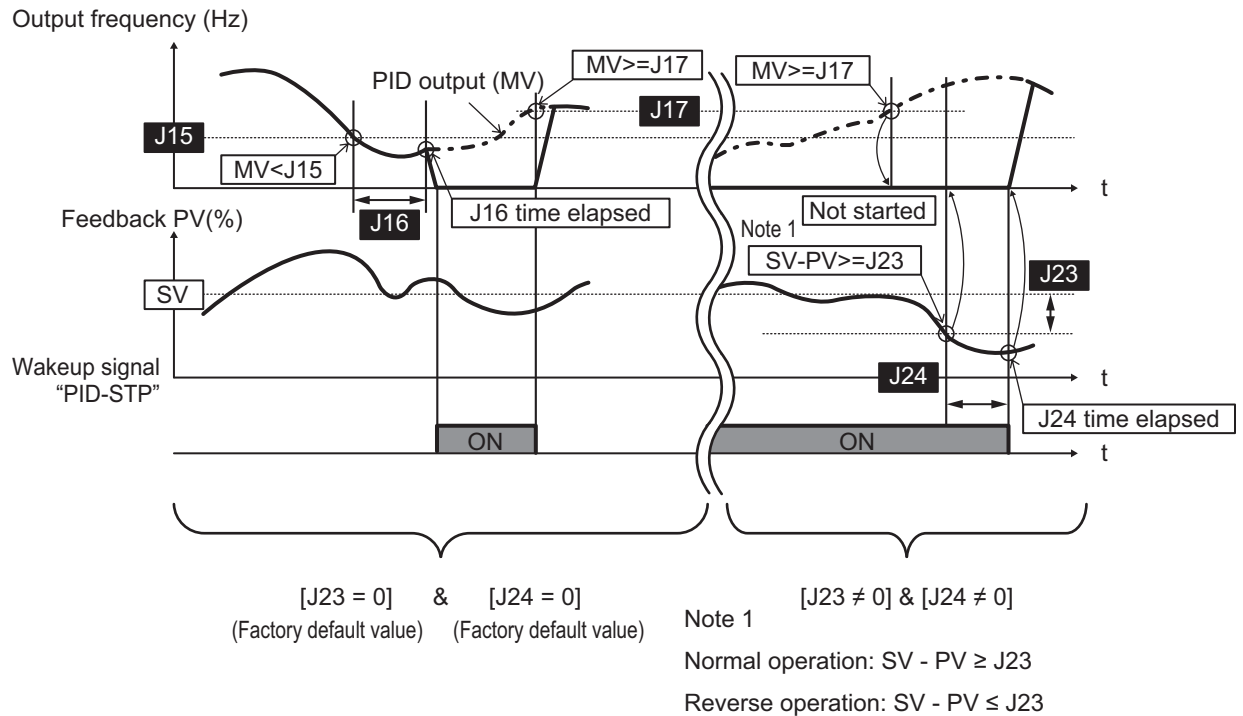

## Multistep PID Command

- Multistep PID Command 1 to 3 (J136, J137, J138)

The PID command value can be applied by the multi-step command of digital input. Allocate "171: PID-SS1" and "172: PID-SS2" to the input terminals [DI1] to [DI7].

PID-SS2	PID-SS1	PID multi-step command
OFF	OFF	Not selected
OFF	ON	J136: PID Control Multistep PID Command 1 Change range: -999.0 to 0.00 to 9990
ON	OFF	J137: PID Control Multistep PID Command 2 Change range: -999.0 to 0.00 to 9990
ON	ON	J138: PID Control Multistep PID Command 3 Change range: -999.0 to 0.00 to 9990

## Anti-reset Windup

- PID Control Anti-reset Windup Width (J10)

Restrains overshooting during control by a PID controller. If the difference between the command and the feedback value is outside the range of the set value, the integrator holds the value and the integration operation is not performed.

Data setting range: 0 to 200 (%)

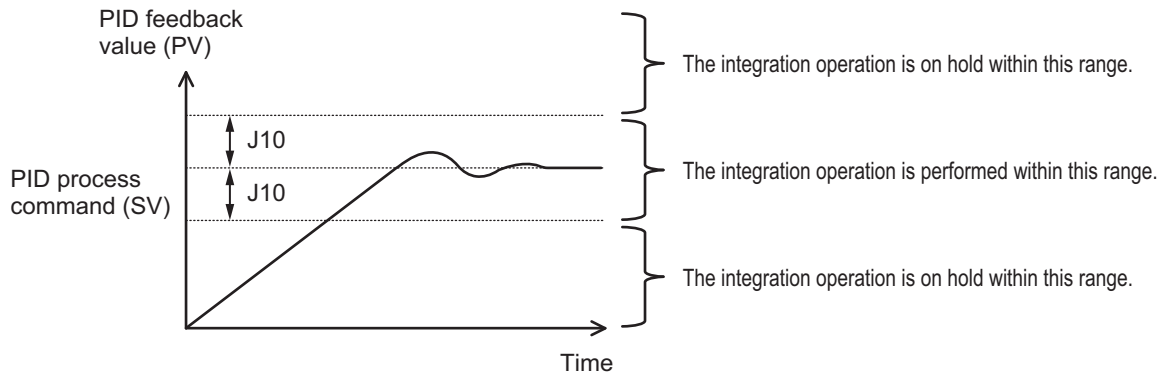

## PID Output Limiter

It is possible to set a limiter for the upper limit and lower limit in the PID output exclusively for PID control. The limiter is disabled when PID cancellation “Hz/PID” is entered and operation is performed at the normal frequency setting.

- PID Control PID Output Upper Limit (J18)

The upper limit value for the limiter of PID controller output is set in percentage. If the set value is specified as 999, the settings of 1st Frequency Upper Limit (F15) are followed.



- PID Control PID Output Lower Limit (J19)

The lower limit value for the limiter of PID controller output is set in percentage. If the set value is specified as 999, the settings of 1st Frequency Lower Limit (F16) are followed.

## Setting Dancer Control

- PID Control Operator PID Reference Position for Dancer (J57)

The reference position during dancer control is set in the range of -100% to 100%. If J02 =0 (Operator) is set, this parameter is enabled as the dancer reference position.

The PID command can also be applied by the  /  keys on Operator. In such a case too, the value of J57 changes along with this parameter.

- PID control (Dancer control gain switching) (J58 to J61)

When the position of the dancer roll (feedback) enters the PID Control PID Reference Position Detection Width for Dancer (J58), the PID constant of the PID controller is switched from J03, J04 and J05 to J59, J60 and J61. It is possible to increase the gain and thus improve the responsiveness, and increase the accuracy.

PID Control PID \_x000D\_ Reference Position Detection Width for Dancer (J58)

Set in the range of 1% to 100%. If set to 0, switching of the PID constant is not performed.

PID Control P Gain 2 (J59)

PID Control I Integral Time 2 (J60)

PID Control D Differential Time 2 (J61)

Same as PID Control P Proportional Gain (J03), PID Control I Integral Time (J04) and PID Control D Differential Time (J05).

- PID Control Block Selection (J62)

It is possible to select whether to add or subtract the output of the PID controller of dancer control to or from the main settings. It is also possible to select whether to perform control of the main settings by the output of the PID controller based on the ratio, or to perform correction based on the absolute value (Hz).

J62 data		Block selection		
Decimal	bit 1	Decimal	bit 1	Decimal
0	0	0	0	0
1	0	1	0	1
2	1	2	1	2
3	1	3	1	3





## Terminal Input Function

- PID control cancellation “PID” (20: PID enabled/disabled)

When “PID enabled/disabled (20: PID)” is ON, switching occurs from PID control to manual frequency setting.

Input signal “Hz/PID”	Function selected
OFF	PID control enabled
ON	PID control disabled (manual frequency setting)

“PID (20: PID enabled/disabled)” OFF -> ON operation

If, during PID operation, “Hz/PID” is switched from OFF to ON and set to the PID canceled state, and F01/C30 is set to 0:  or  keys on Operator, 7: Terminal command UP / DWN control, 8:  or  keys on Operator (balanceless-bumpless switching available), the output frequency is inherited (balanceless-bumpless). If PID control is set to “Opposite operation available” (J01 = 4, 5), and PID output is “During reverse rotation,” the output frequency of PID control is not inherited and becomes 0 Hz.

“PID (20: PID enabled/disabled)” ON -> OFF operation

When PID operation is restored by switching “Hz/PID” from ON to OFF during normal operation, and PID process control (J01 = 1, 2, 4, 5) is enabled, the output frequency during switching is inherited in the MV (balanceless-bumpless), and shifted to PID control. When inverse operation is being performed due to a negative setting of the frequency reference during PID cancellation, and the PID control is set to “Opposite operation not available” (J01 = 1, 2), the absolute value of the output frequency is inherited in the MV, and switching occurs from reverse output to normal output.

- Normal/inverse operation switching “IVS”

In modes in which process control is performed by the PID control function built into the inverter, PID control enable (operation based on PID controller) and PID control disable (operation based on the manual frequency setting) can be switched by the “PID (20: PID enabled/disabled)” terminal. Input Terminal [AI1, AI2] Normal/Inverse Operation for 1st Frequency Command and PID Control Function Selection (J01) can be combined with the Switch normal/inverse operation “IVS” signal on each operation, and determination of normal/inverse operation is performed as follows.

When PID control is enabled: Normal/reverse operation of PID controller output (frequency setting)

PID Control Function Selection (J01)	Input signal IVS	Operation
1: Process normal operation	OFF	Normal operation
4: Process normal operation, opposite operation available	ON	Reverse operation
2: Process inverse operation	OFF	Reverse operation
5: Process inverse operation, opposite operation available	ON	Normal operation

When PID control is disabled: Normal/reverse operation of manual frequency setting

Input Terminal [AI1, AI2] Normal/Inverse Operation for 1st Frequency Command (C53)	Input signal IVS	Operation
0: Normal	-	Normal operation
1: Inverse	-	Reverse operation



#### Additional Information

When process control is performed by the PID control function built into the inverter, the Normal/Inverse switching "IVS" signal is used for switching normal/reverse operation of the output (frequency setting) of the PID controller, and is not used for normal/reverse operation switching in the manual frequency setting.

- PID differential/integral reset "PID-RST"  
When "PID-RST" is turned ON, the derivative terms and integration terms of the PID controller are reset.
- Hold PID integral component "PID-HLD"  
When "PID-HLD" is turned ON, the integration terms of the PID controller are held.

## Terminal Output Function

- Under PID control "PID-CTL"  
When PID control is enabled and the RUN command is ON, the ON signal is output.



#### Additional Information

During PID control, although control is in progress, the inverter may stop as a result of the sleep function. Even in such a case, the "PID-CTL" signal remains ON.

## PID Feedback Disconnection Detection

If "0: Analog input terminals (AI1, AI2 (All function), AI2 (AIV function))" is selected for PID Control Feedback Selection (E119), and "5: PID feedback value" is selected for Input Terminal [AI2] Function Selection (All) (E62), disconnection is detected and processed as an alarm (cof alarm). At Current Input Wire Break Detection (H91), set whether disconnection detection is enabled or disabled, and also set the time for judging a disconnection (a disconnection is judged when the current input of terminal [AI2] is below 2 mA).



If other than “0: 4 to 20 mA Unipolar” is set to Input Terminal [AI2] Operation Selection (All) (C40), this function does not operate.

Parameter No.	Function name	Data	Default data	Unit
H91	Current Input Wire Break Detection	0.0: Disable alarm detection 0.1 to 60.0: Issue alarm after set time	0.0	s

### 7-9-14 Automatic Energy-saving Operation Function

This function automatically adjusts the inverter output power during constant speed operation to the minimum level. It is suitable for load with reduced torque characteristics, such as fans and pumps. To perform energy-saving operation using this function, set Energy-saving Operation Function Selection (E124) to “1: Energy-saving operation.”

When the automatic energy-saving operation is enabled, it is possible to select Enable during running at constant speed, and Enable during running at constant speed and acceleration/deceleration with Auto Energy Saving Operation Condition Selection (H67).

Because this function controls the output power to the minimum necessary level, the motor may stall if the rapid load fluctuation, such as impact load, occurs, which may result in an overcurrent trip.

Parameter No.	Function name	Data	Default data	Unit
E124	Energy-saving Operation Function Selection	0: Disable energy-saving operation 1: Energy-saving operation	0	-
H67	Auto Energy Saving Operation Condition Selection	0: Enable only at constant speed 1: Enable in all modes	0	-

### 7-9-15 Commercial Switching (CS)

Commercial operation and inverter operation are switched by the “CS” terminal (15: Commercial switch).

When switching between commercial operation/inverter operation is performed in an external sequence, input the CS allocated to multifunction input in accordance with the operation chart below. Then, the inverter can be started from the commercial power supply frequency regardless of the set frequency of the inverter, and the motor during the commercial operation can be smoothly switched to inverter operation.

This function is enabled when Drive Control Selection (F42/A14) = “0, 1, 3, 4.”

When the power supply frequency is 50 Hz, use “15: CS” and when the power supply frequency is 60 Hz, use “16: SW60.”

Parameter No.	Function name	Data	Default data	Unit
F42/A14	1st Drive Control Selection/2nd Drive Control Selection	0: IM V/f control 1: IM Dynamic torque vector control 3: IM V/f control with speed sensor 4: IM Dynamic torque vector control with speed sensor	-	-

Parameter No.	Function name	Data	Default data	Unit
E01 to E05, E98, E99	Input Terminal [DI1] to [DI7] Function Selection	15: CS (Commercial switch) 16: SW60 (Commercial switch (60 Hz))	-	-
H13	Power Interruption Restart Wait Time	0.1 to 100.0	0.5	s

## Switching between Inverter Operation and Commercial Power Supply Operation

- Follow the sequence diagram given below to switch among the terminals MC1 to MC3, FW and CS, and switch from inverter operation to commercial power supply operation. When the CS terminal turns ON, the inverter shuts off its output and the motor falls in a free-run state.
- When the commercial switching signal “CS” or “SW60” is turned OFF, the operation switches to inverter operation from commercial power supply operation, and following the elapse of the Power Interruption Restart Wait Time (H13), the 50 Hz output starts when the signal during commercial 50 Hz selection turns OFF, and the 60 Hz output starts when the signal during commercial 60 Hz selection turns OFF. (Start of pull-in operation)
- If the output frequency is deviating from the motor rotation speed, perform adjustment of the output frequency during the pull-in operation based on the fall rate of restart after momentary power failure (H14).

● Connection example for commercial power supply operation

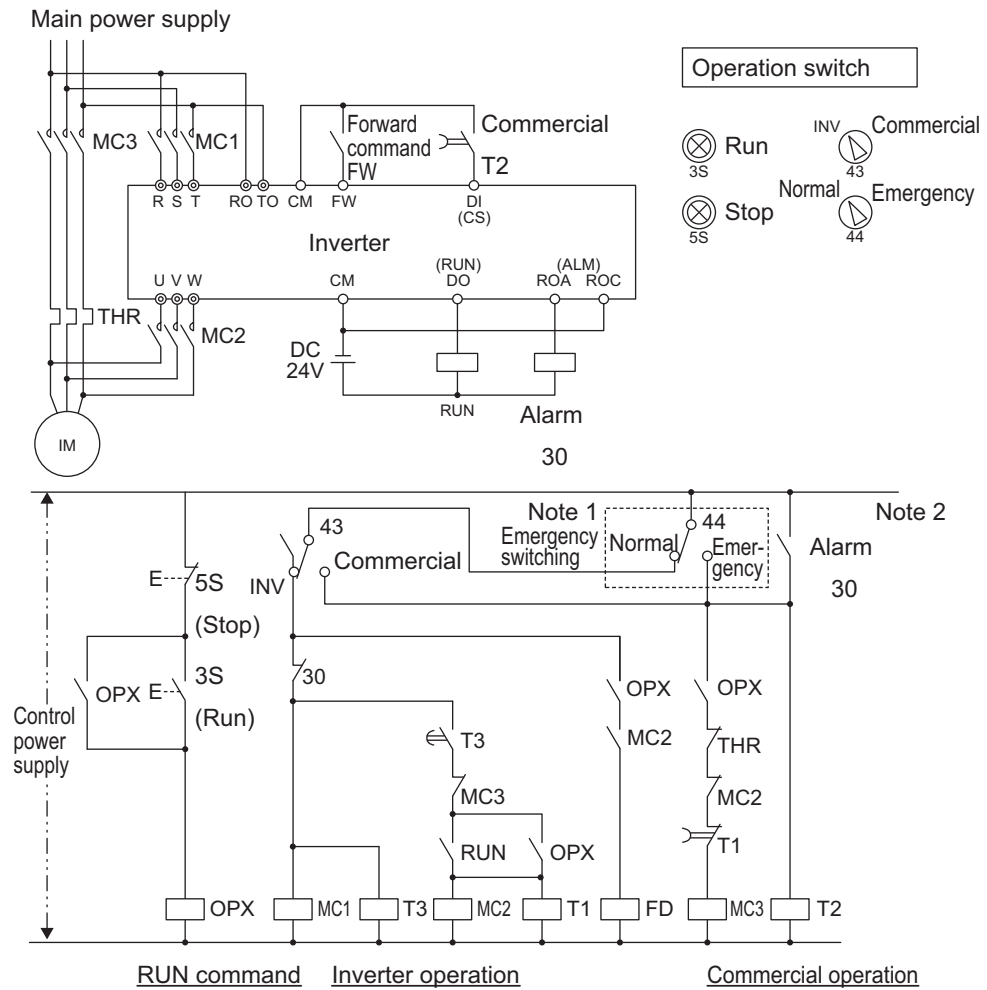

- Note 1.** Emergency switching  
Manual switching performed when the sequence for switching to commercial power supply is not performed normally due to a major breakdown of the inverter.
- Note 2.** When an alarm is issued in the inverter, switching to commercial power supply occurs automatically.

● Timing diagram for commercial switching

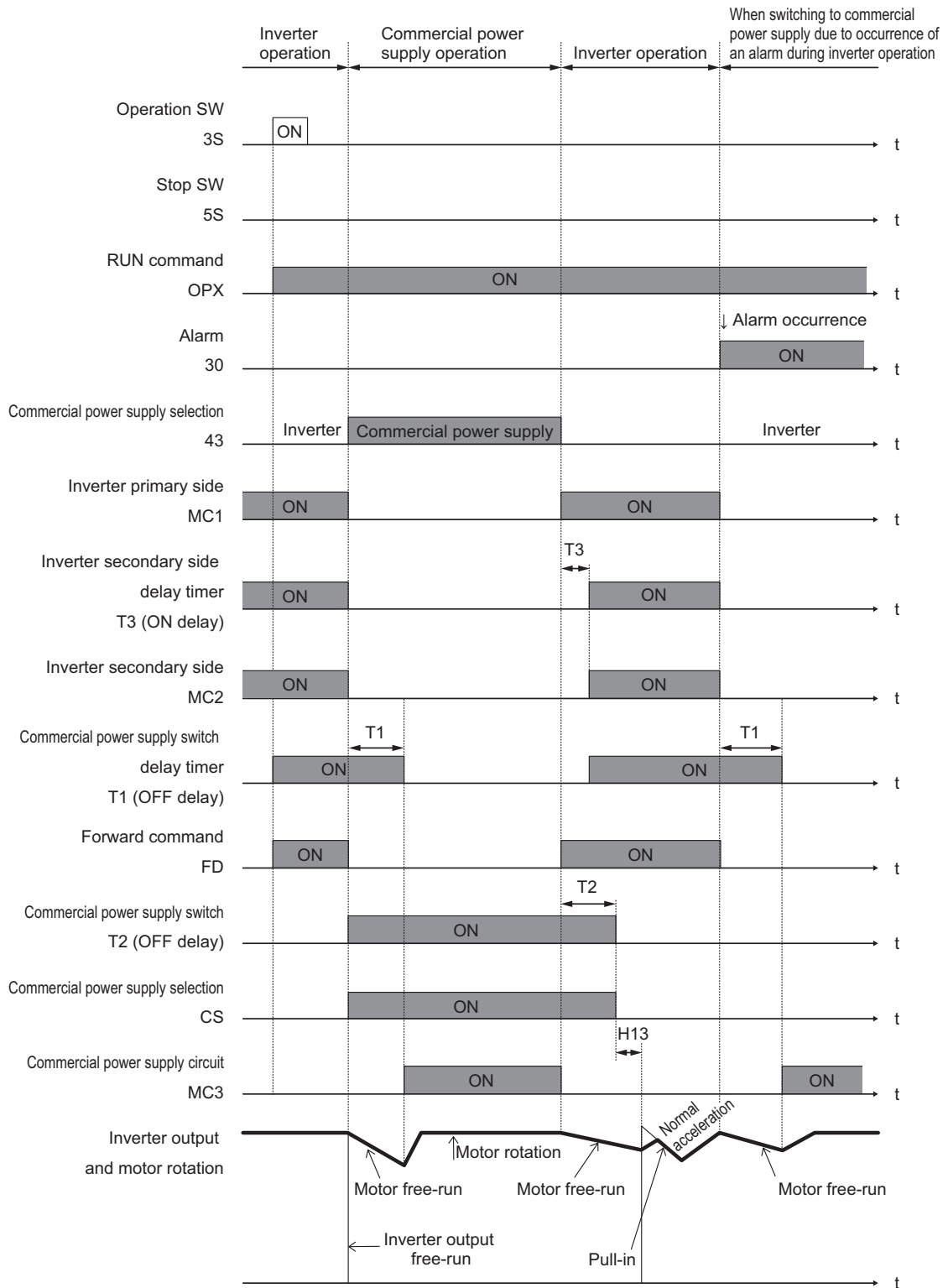

**7-9-16 Output current fluctuation damping**

When the motor is driven, the output current of the inverter may fluctuate (current fluctuation) due to the motor characteristics or the backlash at the load machine side. This parameter increases the 1st Output Current Fluctuation Damping Gain (H80) and 2nd Output Current Fluctuation Damping Gain (A41) when the control function for suppressing such current fluctuation is to be adjusted.

Parameter No.	Function name	Data	Default data	Unit
H80/A41	1st Output Current Fluctuation Damping Gain/2nd Output Current Fluctuation Damping Gain	0.00 to 1.00	0.20	-

### 7-9-17 Pulse Train Frequency Input

Pulse train input can be used for the frequency reference, operation target used for frequency reference and PID feedback value in PID control.

- To use pulse train input for the frequency reference, set Frequency Reference Selection (F01/C30) to “12: Pulse train input.”
- To use pulse train input for the operation target, set Frequency Reference Selection (F01/C30) to “13: Calculation result” and set Frequency Calculation Operation Target 1/2 (E131/E132) to “7: Pulse train frequency.”
- To use pulse train input for PID feedback, set PID Control Feedback Selection (E119) to “3: Pulse train frequency.”
- Pulse train input uses input terminals [PIA], [PIB] and [PIZ].

Parameter No.	Function name	Data	Default data	Unit
F01/C30	1st Frequency Reference Selection/ 2nd Frequency Reference Selection	12: Pulse train input 13: Calculation result	0	-
E119	PID Control Feedback Selection	3: Pulse train frequency	0	-
d14	Input Terminal [PIA][PIB] Pulse Input Format Selection	0: Pulse train signing/pulse train input 1: Forward/reverse rotation pulse 2: Quadrature A/B signal (B phase lead) 3: Quadrature A/B signal (A phase lead)	2	-
d15	Input Terminal [PIA][PIB] Encoder Pulse Resolution	20 to 60000	1024	Pulse
d16	Input Terminal [PIA][PIB] Pulse Scaling Factor Denominator	1 to 32767	1	-
d17	Input Terminal [PIA][PIB] Pulse Scaling Factor Numerator	1 to 32767	1	-
d18	Input Terminal [PIA][PIB] Pulse Train Filter Time Constant	0.000 to 5.000	0.005	s
W55	Pulse Input (A/B Phase [PIA][PIB])	-327.68 to 327.67	-	kp/s
W56	Pulse Input (Z Phase [PIZ])	0 to 16000	-	p/s
W139	Pulse Train Frequency Monitor	-163.84 to 163.83	-	%

Parameter No.	Function name	Data	Default data	Unit
Related function		Frequency Calculation Operation Target 1 (E131) Frequency Calculation Operation Target 2 (E132) Frequency Addition Sign Selection (E135)		

• Pulse train input method (d14)

By entering a pulse train in the input terminals [PIA] and [PIB] of the inverter control circuit, it is possible to make a frequency setting proportional to the frequency of the pulse. The pulse train input method is specified by the Input Terminal [PIA][PIB] Pulse Input Format Selection (d14). Input can be made in four types, namely the Pulse train signing/pulse train input, Forward and reverse pulse, and Quadrature A/B signal (A phase lead, B phase lead).

d14 data	Target terminal	Pulse input method	Remarks
0	Input Terminal [PIA]	Pulse train signing	<p>A speed command corresponding to the frequency of pulse train input is applied. Moreover, the polarity of the speed command can be set by the pulse train signing.</p>
	Input Terminal [PIB]	Pulse train input	
1	Input Terminal [PIA]	Forward rotation pulse	<p>A speed command corresponding to the frequency of pulse train input is applied. If the input pulse is a forward rotation pulse, it results in straight polarity, and if the input pulse is a reverse rotation pulse, it results in reverse polarity.</p>
	Input Terminal [PIB]	Reverse rotation pulse	
2	Input Terminal [PIA] Input Terminal [PIB]	Quadrature A/B signal (B phase lead)	<p>A speed command with polarity is applied based on the phase difference and frequency, by two types of pulse signals having a 90° phase difference (B phase lead).</p>

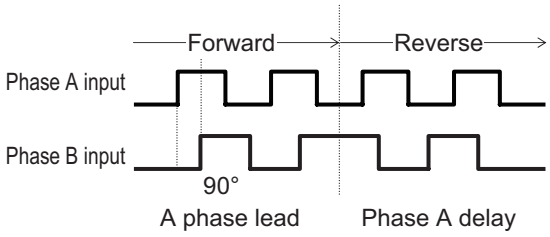
d14 data	Target terminal	Pulse input method	Remarks
3	Input Terminal [PIA]	Quadrature A/B signal (A phase lead)	<p>The polarity is reversed (A phase lead becomes forward rotation) when Input Terminal [PIA][PIB] Pulse Input Format Selection (d14) = 2. If the A phase and B phase are wired in the reverse order, the polarity can be corrected by setting Input Terminal [PIA][PIB] Pulse Input Format Selection (d14) = 3.</p> 
	Input Terminal [PIB]		

- Input Terminal [PIA][PIB] Encoder Pulse Resolution (d15)  
Set the number of encoder pulses of pulse train input.

- Pulse scaling factor 1 (d16), Pulse scaling factor 2 (d17)  
(When Modbus coil spec. No. 001C hex RL (communication is enabled) is 1))

$$f^* [\text{Hz}] = N_p [\text{kp/S}] \times \frac{\text{Input Terminal [PIA][PIB] Pulse Scaling Factor Numerator (d17)}}{\text{Input Terminal [PIA][PIB] Pulse Scaling Factor Denominator (d16)}}$$

$f^* [\text{Hz}]$ : Frequency set value

$N_p [\text{kp/s}]$ : Entered input pulse frequency

- Filter time constant (d18)  
Set the filter time constant with respect to the pulse train input.
- PID feedback based on pulse train input (E119 = 3)  
Perform the same processing as the frequency setting process for the pulse train, and convert to the feedback value with the maximum frequency with respect to the frequency reference value of the result as 100%. When one of the following conditions is satisfied at the same time, pulse train input is used for both the set frequency and PID feedback.
  - Set “12: Pulse train input” to 1st Frequency Reference Selection (F01)/2nd Frequency Reference Selection (C30).
  - Set “13: Calculation result” to 1st Frequency Reference Selection (F01)/2nd Frequency Reference Selection (C30), and set “7: Pulse train frequency” to Frequency Calculation Operation Target 1 (E131)/Frequency Calculation Operation Target 2 (E132).
- Operation frequency input setting based on pulse train input (E131/E132 = 5)  
Perform the same processing as the frequency setting process for the pulse train, and set the frequency reference value of the result as the selection value of the operation frequency.

### 7-9-18 LAD Cancel Function

“LAD” is the function for calculating the acceleration/deceleration time. The LAD cancel function forcibly sets the acceleration/deceleration time to 0.

When the LAC terminal is turned ON, the frequency acceleration/deceleration function (LAD) is disabled and the frequency reference is output momentarily.

This function is also applicable to the acceleration/deceleration during the jogging operation and the deceleration during forced stop.

Parameter No.	Function name	Data	Default data	Unit
E01 to E05, E98, E99	Input Terminal [DI1] to [DI7] Function Selection	84: LAC (LAD Cancel)	-	-
Related function		F07, F08, E10 to E15		

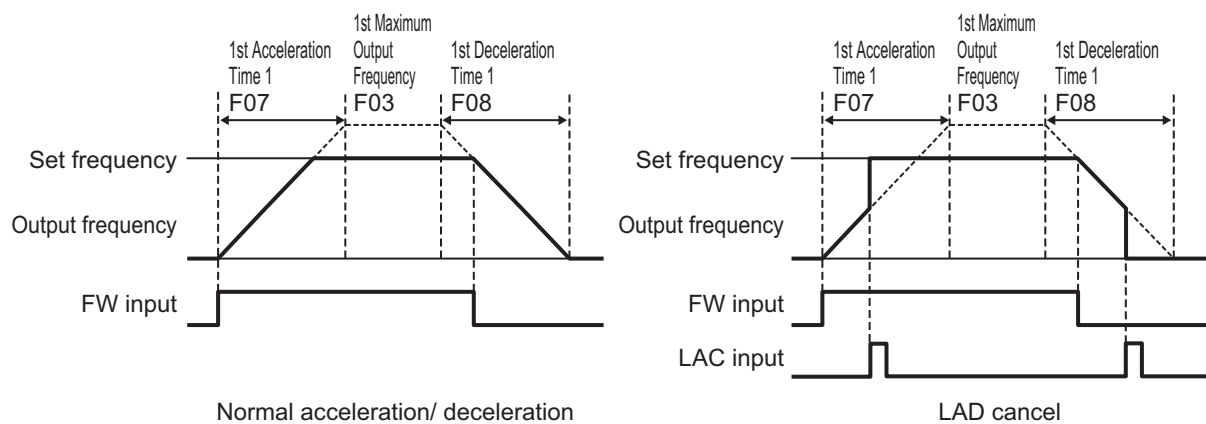

### 7-9-19 Servo Lock Function

The servo lock function is used to control the position of the motor, and continue to retain the position even when an external force is applied.

It is enabled only during vector control with speed sensor. The servo lock function is enabled by turning the LOCK terminal ON.

If operation is stopped even with position control disabled (SPD terminal ON) when the servo lock is enabled, a deceleration is performed to the stop frequency, then position control is performed with the position where the output frequency becomes 0 taken as the target stop position, and then servo lock is performed.

The servo lock operates at a low speed, and therefore, if it is used by applying an external force over a long period of time, overheat protection may be activated.

Servo lock is started when all of the following conditions are satisfied.

- RUN command is OFF, or set frequency < stop frequency (F25)
- LOCK terminal ON
- [“0: Output frequency, Detected speed” is set for 1st Stop Frequency Detection Method Selection (F38) and speed detection value is Stop Frequency (F25) or less] or [“1: Frequency reference” is selected for 1st Stop Frequency Detection Method Selection (F38) and frequency reference value is Stop Frequency (F25) or less]



Set the gain for the position control of the servo lock by Servo Lock Gain (J97). The behavior of stopping the inverter during a servo lock, and the axial holding force can be adjusted.

When setting smaller value to J97, the response is delayed, but the behavior becomes smoother and the axial holding force is reduced. When setting larger value, the response becomes faster, but hunting increases and the axial holding force also increases.

Parameter No.	Function name	Data	Default data	Unit
E01 to E05, E98, E99	Input Terminal [DI1] to [DI7] Function Selection	47: LOCK (Servo lock command)	-	-
J97	Servo Lock Gain	0.000 to 9.999	0.010	time
J98	Servo Lock Completion Timer	0.000 to 1.000	0.1	s
J99	Servo Lock Completion Range	0 to 9999	10	Pulse

- When the servo lock command is ON, the voltage is output to the output terminals [U], [V] and [W] of the inverter even if the RUN command has not been turned ON.
- During a servo lock, if the position error becomes four rotations or more by motor shaft conversion, the position control error Ero is output.
- With the servo lock function, as control is started from the 1st Stop Frequency (F25) or less, adjust 1st Stop Frequency (F25) and Gain (J97) to satisfy the following formula:  
1st Stop Frequency (F25) < (4 × Gain (J97) × Maximum output frequency)
- If servo lock control is enabled, the stop frequency continuation operation and rotational direction limitation are disabled.

## 7-9-20 Droop Control

If a single mechanical system is driven by multiple motors, and there is a speed difference in each of the motors, a load unbalance occurs. Droop control is a function for ensuring load balance by providing drooping characteristics to the motor speed in response to an increase in load.

When the output torque is 100%, the output frequency is subtracted by the frequency set at Droop Control (H28), and when the output torque is 0%, the output frequency is subtracted as a percentage that is output according to the frequency reference in accordance with the torque actually being output by the inverter ("Torque Value" (M07)).

The set value of Droop Control (H28) is around the rated slip frequency of the applicable motor.

To enable droop control, turn the DROOP terminal ON.

Parameter No.	Function name	Data	Default data	Unit
H28	Droop Control	-60.0 to 0.0	0	Hz
E01 to E05, E98, E99	Input Terminal [DI1] to [DI7] Function Selection	76: DROOP (Select droop control)	-	-

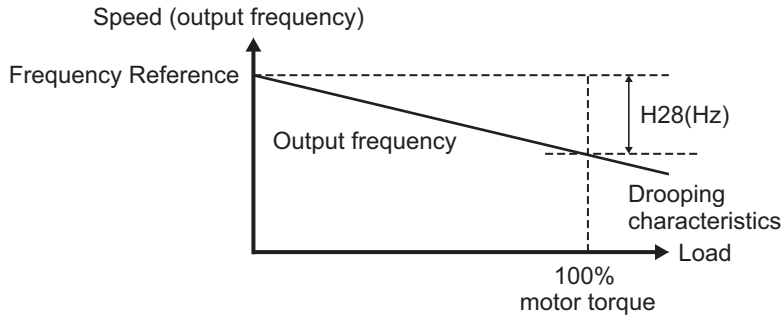

- When using droop control, be sure to perform auto-tuning.
- During droop control for V/f control, the acceleration/deceleration time is enabled for the resultant frequency of droop control so that tripping does not occur even when there is a sudden change in load.

As a result, the reflection of the frequency corrected during droop control on the motor speed under the influence of the acceleration/deceleration time is delayed, and the droop control may operate as disabled.

### 7-9-21 Magnetic Flux Level at Light Load

By setting Magnetic Flux Level at Light Load (H173), the magnetic flux of the motor during a light load can be reduced, and thus, the motor noise can be reduced. This function can be used only during vector control with speed sensor.

This is regardless of Load Mode Selection (F80).

Parameter No.	Function name	Data	Default data	Unit
H173	Magnetic Flux Level at Light Load	10 to 100	100	%

- The magnetic flux command when the Torque Current Command value is less than 50% can be changed. Set the magnetic flux command when the Torque Current Command value is 0% to Magnetic Flux Level at Light Load (H173). Refer to the figure below.

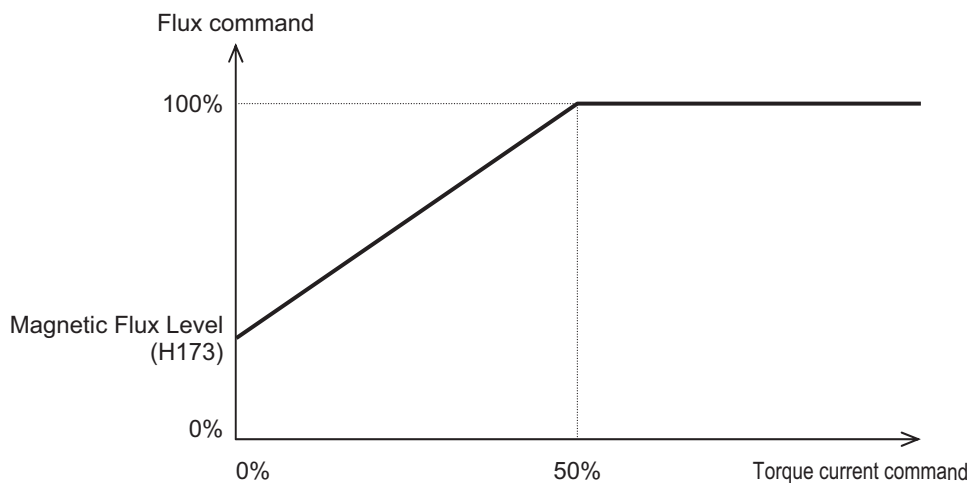

## 7-9-22 Pre-excitation

The motor generates torque through magnetic flux and torque current. Since the establishment of magnetic flux has a lag element, sufficient torque is not generated at the time of starting.

Pre-excitation is a function for establishing the magnetic flux before startup to ensure sufficient torque even during the time of starting.

There are two methods for issuing pre-excitation commands: one is to execute for the period of Pre-excitation Timer (H85) after the RUN command is turned ON, and the other is to turn ON the EXITE terminal and apply pre-excitation until the RUN command is input.

### Controlling by Pre-excitation Timer

When the pre-excitation (Timer) elapses, it is judged that magnetic flux has been established, and acceleration is started. Secure sufficient time for establishment of magnetic flux with Pre-excitation Timer (H85).

The appropriate value of the pre-excitation (Timer) is different for each capacity. As a standard, consider it equivalent to the default value of the Power Interruption Restart Wait Time (H13).

This function is disabled when the pre-excitation timer is set to 0.00.

Parameter No.	Function name	Data	Default data	Unit
H85	Pre-excitation Timer	0.00: Disable 0.01 to 30.00	0.00	s
H84	Pre-excitation Level*1	100 to 400	100	%

- \*1. Pre-excitation Level (H84) sets the ratio with the rated magnetic flux as 100%. This is used to raise the output current to more than specified to shorten the pre-excitation timer. Generally, there is no need to change the settings. If a set value is too large, instantaneous overcurrent (alarm code: OC) sometimes is generated.

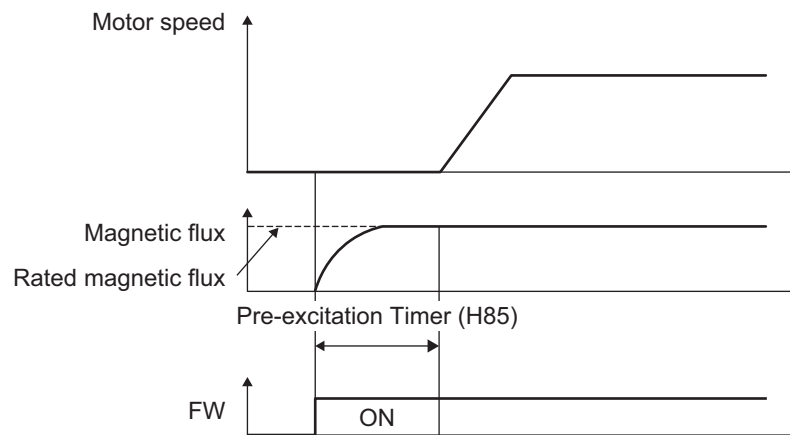

### Controlling by Pre-excitation Command Terminal (32: EXITE)

Pre-excitation starts operating when the EXITE terminal is turned ON regardless of the setting of Pre-excitation Timer (H85). After this, when the RUN command is input, pre-excitation operation ends, and acceleration starts. When the time until the RUN command is input is short, establishment of magnetic flux sometimes does not arrive at a sufficient level. In this case, lengthen the time until the RUN command is input.

Parameter No.	Function name	Data	Default data	Unit
E01 to E05, E98, E99	Input Terminal [DI1] to [DI7] Function Selection	32: EXITE (Pre-excite)	-	-

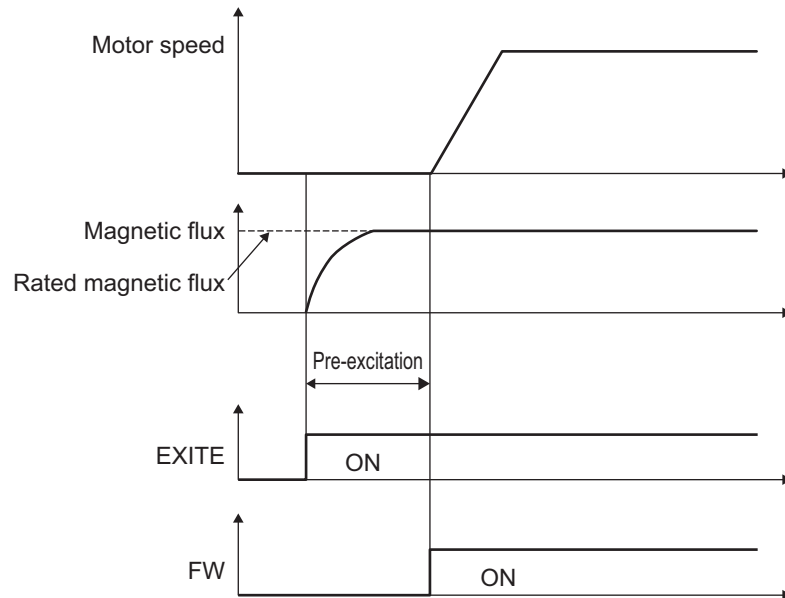

- The pre-excitation function is disabled in V/f control (including automatic torque boost and torque vector). Substitute it with DC braking or starting frequency continuation.
- Even when the motor is stopped by the pre-excitation operation, the voltage is output to the output terminals U, V and W of the inverter.

### 7-9-23 Forced Stop

The forced stop function is used to perform a deceleration stop by Deceleration Time for Forced Stop (H56) when the STOP terminal is turned OFF. After the deceleration stop, the operation error (alarm code: Er6) is displayed and the status changes to alarm status.

When a forced stop is detected, the STOP-OUT terminal turns ON.

Parameter No.	Function name	Data	Default data	Unit
H56	Deceleration Time for Forced Stop	0.00 to 6000	6.00	s
E01 to E05, E98, E99	Input Terminal [DI1] to [DI7] Function Selection	30: STOP (Force to stop)*1	-	-
E20, E21, E27	Output Terminal [DO1] Function Selection, Output Terminal [DO2] Function Selection, Output Terminal [ROA, ROB] Function Selection	152: STOP-OUT (Forced stop detection)	-	-

\*1. As standard, Force to stop (30: STOP) is an NC contact. To use the function for an NO contact, set "1030."

## 7-9-24 Overload Stop Function

This function is used to detect the load condition, and if the state exceeding the Overload Stop Detection Level (J64) continues for the Overload Stop Detection Timer (J67) or longer, stop operation is performed by the overload stop function.

Select the stop operation at Overload Stop Mode Selection (J65). If “0: Disable” is selected, the overload stop function is disabled.

The overload stop function is enabled only for the 1st control.

Select the operation to detect at Overload Stop Operation Mode (J66).

Select the item to detect at Overload Stop Item Selection (J63).

Parameter No.	Function name	Data	Default data	Unit
J65	Overload Stop Mode Selection	0: Disable 1: Deceleration stop 2: Free run stop 3: Torque limit operation (Deceleration)	0	-
J63	Overload Stop Item Selection	0: Torque 1: Current	0	-
J64	Overload Stop Detection Level	20 to 200 The data is interpreted as the rated output current of the inverter for 100%.	100	%
J66	Overload Stop Operation Mode	0: During constant speed running and deceleration 1: During constant speed running 2: Anytime	0	-
J67	Overload Stop Detection Timer	0.00 to 600.00 s	0.00	s
J90	Overload Stop Function P gain	0.000 to 2.000; 999 0.000 to 2.000 times 999: 0.050 times	999	time
J91	Overload Stop Function Integral time	0.001 to 9.999; 999 0.001 to 9.999s 999: 0.025s	999	s
J92	Overload Stop Function Current level	50.0% to 150.0%	100	%
E01 to E05, E98, E99	Input Terminal [DI1] to [DI7] Function Selection	46 : OLS (Enable overload stop)	-	-

### Overload Stop Enabled OLS

Turning the OLS terminal ON enables overload stop and turning the terminal OFF disables overload stop.

Note that if overload stop is disabled by turning OFF the OLS terminal in a state when the inverter has stopped due to overload stop, the inverter will restart.

### Overload Stop Mode Selection (J65)

- Select the stop operation at Overload Stop Mode Selection (J65). If “0: Disable” is selected, the overload stop function is disabled.

### ● For operation selection (J65 = 1, 2)

If deceleration stop (J65 = 1) is set when output torque or output current has continued for the detection timer (J67) or longer set with the Overload Stop Detection Level (J64), a deceleration stop is performed at the selected deceleration time.

When free run stop (J65 = 2) is set, inverter immediately shuts down and the motor enters the free-run state.

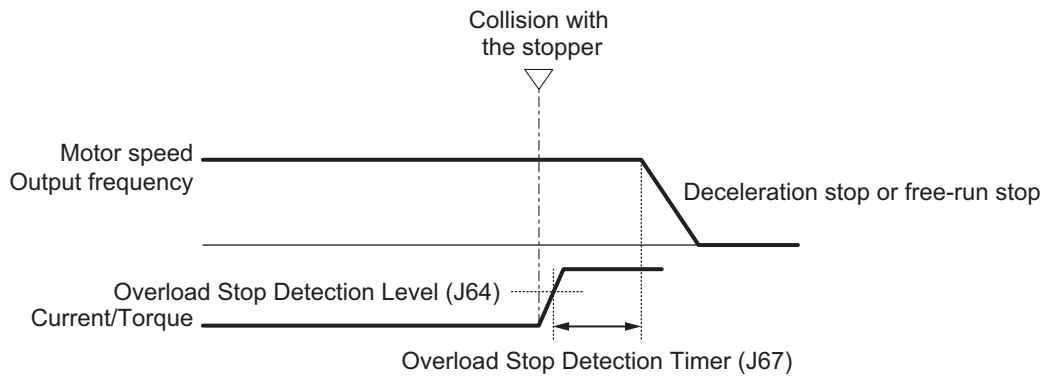

### ● For operation selection (J65 = 3)

- PI control is started by the set values of Overload Stop Function P gain (P) (J90) and Overload Stop Function Integral time (J91) when the Overload Stop Detection Level (J64) is reached. Torque is controlled by PI control so that the Overload Stop Detection Level (J64) is maintained. When the Frequency Lower Limit (F16/E118) is reached, control is switched to current control. Overload Stop Item Selection (J63) is not related to this setting.

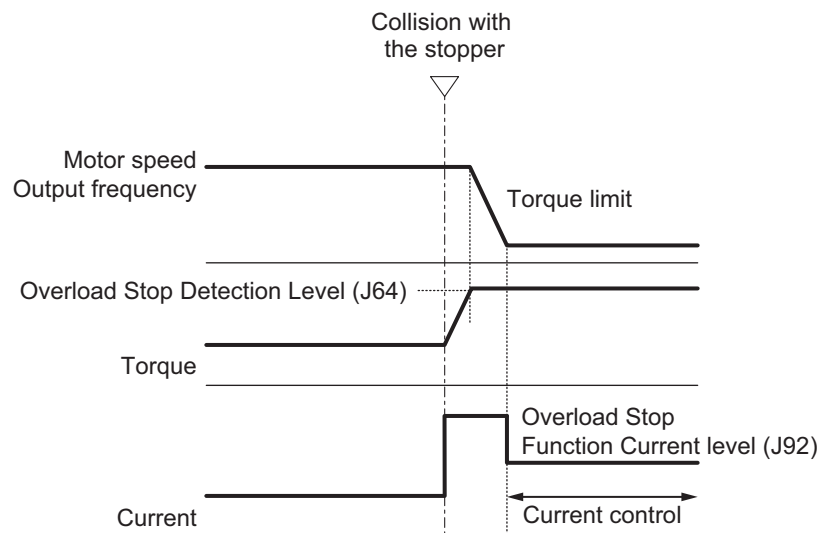

## Proportional Gain (P), Integral Time (I) and Current Limitation Level

When “3: Torque limit operation (Deceleration)” function is selected for Overload Stop Mode Selection (J65), the parameters described below can be set.

- Overload Stop Function P gain (J90)

If the response of the torque limitation operation is slow, increase the gain, and if hunting occurs, decrease the gain.

- Overload Stop Function Integral time (J91)  
If the response of the torque limitation operation is slow, decrease the integral time, and if hunting occurs, increase the integral time.
- Overload Stop Function Current level (J92)  
This function is used to correct the current command during current limitation. When the set value is increased, the retention torque increases, but an inverter overload alarm (0LU) or a motor overload alarm (0L1) may occur, and vibrations may occur in the mechanical system.

### 7-9-25 Battery Operation Enable Command (BATRY)

When the BATRY terminal is turned ON, undervoltage protection is disabled, and the motor can be operated even in an undervoltage state. In an event that an elevator fails to stop at a normal position due to power failure, this command is expected to operate the elevator to the normal position with a low-voltage and small-capacity emergency power supply.

When "BATRY" is allocated to the input terminal, the momentary power failure operation is not performed regardless of the setting of Power Interruption Restart Mode Selection (F14), and the inverter trips during a power failure.

When the BATRY terminal is ON, the input phase loss protection is disabled regardless of the setting of Input Phase Loss Protection Function Selection (H411).

While the BATRY terminal is ON, the IRDY terminal turns OFF.

Parameter No.	Function name	Data	Default data	Unit
E01 to E05, E98, E99	Input Terminal [DI1] to [DI7] Function Selection	59: BATRY (Enable battery-driven operation)	-	-
E20, E21, E27	Output Terminal [DO1] Function Selection, Output Terminal [DO2] Function Selection, Output Terminal [ROA, ROB] Function Selection	10: IRDY (Operation ready signal)	-	-

### 7-9-26 Universal Terminal

- The input terminal is not used as startup of the inverter functions, but it can be used as a signal monitor.
- The inverter status is not output; the value set to parameters can be output from output terminals [DO1], [DO2] and [ROA, ROB].

#### Universal DI

When "25:U-DI (Universal DI)" is allocated to the input terminal, ON/OFF can be checked by Operation command (S06) and the input signal can be checked by Input Terminal Monitor (W40) regardless of inverter operation.

Parameter No.	Function name	Data	Default data	Unit
E01 to E05, E98, E99	Input Terminal [DI1] to [DI7] Function Selection	25:U-DI (Universal DI)	0	-
S06	Operation command	0000 to FFFF hex Bit15: RST Bit14: DI7 Bit13: DI6 Bit6: DI5 Bit5: DI4 Bit4: DI3 Bit3: DI2 Bit2: DI1 Bit1: REV Bit0: FWD	-	-
W40	Input Terminal Monitor	0000 to FFFF hex Bit12: EN2 Bit11: EN1 Bit6: DI5 Bit5: DI4 Bit4: DI3 Bit3: DI2 Bit2: DI1 Bit1: DI7 Bit0: DI6	-	-

## Universal DO

When “27: OPO (Option board output)” is allocated to the output terminal, output is performed from the corresponding output terminal when data is written to the Communication Data Terminal [DO] (S07) from communication regardless of inverter operation.

Parameter No.	Function name	Data	Default data	Unit
S07	Communication Data Terminal [DO]	Bit8: RO Bit1: DO2 Bit0: DO1	0	-

## Universal AO

When “10: Universal AO” is allocated to the analog output terminal, output is performed from the analog terminal when data is written to the Communication Data Terminal [AO] (S12) from communication. Full scale is assumed for a numeric value of 20000.

Parameter No.	Function name	Data	Default data	Unit
F31	Output Terminal [AO] Function Selection	10: Universal AO	0	-
S12	Communication Data Terminal [AO]	-32,768 to 32,767 (-20,000 = -100%, 20,000 = 100%)	0	-



## 7-9-27 Protection/Maintenance Mode Selection Function

Main circuit capacitor life judgment selection, main circuit capacitor life judgment, inrush current prevention resistor overheat detection, and braking transistor broken detection operations can be selected and set as combined operations.

Parameter No.	Function name	Data	Default data	Unit
H98	Protection/Maintenance Function Mode Selection	0 to 255	80	-

Set function settings as binary values to their respective bits, and set the resulting data as decimal data to Protection/Maintenance Function Mode Selection (H98).

The following shows the settings of each bit and each function.

Bit	Function	Data = 0	Data = 1
Bit 0 to 2	Reserved	-	-
Bit 3	Main circuit capacitor life judgment standards selection	Default value	User setting
Bit 4	Judge main circuit capacitor life	Disable	Enable
Bit 5	Detect inrush current prevention resistor overheat	Enable	Disable
Bit 6	Braking transistor error detection	Continuous running	Alarm processing
Bit 7	Reserved	-	-

Use the reserved bit fixed at 0.

Below are the details of each function.

### Main circuit capacitor life judgment selection (Bit 3)

Either of the factory default standards or user setting standards can be selected as the criteria level for judging the life of the main circuit capacitor.

When user setting standards are selected, the reference level must be measured and set beforehand. For details, refer to *7-8-10 Capacitor Life Warning Signal (WAC)* on page 7-96.

### Judge main circuit capacitor life (Bit 4)

To judge the life of the main circuit capacitor, measure the discharge time when the power supply is shut off. The discharge time is determined by the capacity of the main circuit capacitor and the inverter's internal load. Accordingly, accurate measurement is not possible when the inverter's internal load conditions fluctuate considerably. Life is also sometimes judged erroneously in some conditions. To prevent erroneous judgment of the life of the main circuit capacitor, life judgment based on the discharge time of the main circuit capacitor can be disabled (life judgment based on incrementation of the time that voltage is applied to the main circuit capacitor continues to stay active). For details, refer to *7-8-14 Lifetime Alarm (LIFE)* on page 7-100.

When using the control power supply auxiliary inputs, the load varies considerably. For this reason, during run operation, either disable life judgment and then enable life judgment after aligning conditions at periodic inspection, or measure by a method matched to actual usage conditions.

### **Inrush Current Prevention Resistor Overheat Detection Protection (Alarm Code: 0h6) (Bit 5)**

---

On 0.1 to 15 kW inverters, when overheating of the inrush current prevention resistor inside the inverter is detected when the main circuit power is turned ON and started, the overheat protection function (alarm 0h6) is activated. When startup is slow due to the main circuit power being a variable power supply device, the overheat protection function is sometimes activated. In this case, protection can be disabled.

### **Braking transistor error detection (dba) (Bit 6)**

---

An error in the built-in braking transistor is detected, the inverter is topped, and the alarm dba is displayed. To disable alarm generation without using the braking transistor, set this bit to "0."

# 8

## Communications Functions

This section describes the general-purpose serial communications functions (Modbus communication).

<b>8-1</b>	<b>Communications Specifications</b> .....	<b>8-3</b>
<b>8-2</b>	<b>RS-485 Terminal Arrangement and Connection</b> .....	<b>8-4</b>
<b>8-3</b>	<b>Modbus Communication Parameters</b> .....	<b>8-5</b>
<b>8-4</b>	<b>Modbus Communication Protocol</b> .....	<b>8-7</b>
8-4-1	Message Configuration .....	8-7
8-4-2	Required Communications Time .....	8-9
8-4-3	Normal Response.....	8-9
8-4-4	Abnormal Response.....	8-9
8-4-5	No Response.....	8-10
<b>8-5</b>	<b>Explanation of Each Function Code</b> .....	<b>8-11</b>
8-5-1	Read Coil Status [01 hex].....	8-11
8-5-2	Read from Holding Register [03 hex] .....	8-12
8-5-3	Write to Coil [05 hex] .....	8-13
8-5-4	Write to Holding Register [06 hex].....	8-14
8-5-5	Loop-back Test [08 hex] .....	8-15
8-5-6	Write to Multiple Coils [0F hex].....	8-16
8-5-7	Write to Multiple Holding Registers [10 hex] .....	8-18
8-5-8	Read/Write from/to Multiple Holding Registers [17 hex].....	8-19
8-5-9	Exception Response .....	8-20
<b>8-6</b>	<b>Saving a Change to Holding Register (Enter Command)</b> .....	<b>8-21</b>
8-6-1	How to Issue Enter Command .....	8-21
8-6-2	EEPROM Write Mode .....	8-22
<b>8-7</b>	<b>Modbus Mapping Function</b> .....	<b>8-23</b>
8-7-1	Operation of Modbus Mapping Function .....	8-23
8-7-2	Modbus Mapping Function Settings .....	8-23
8-7-3	Writing to Double-word Data .....	8-25
8-7-4	Troubleshooting for Modbus Mapping Function .....	8-25
8-7-5	Endian Function .....	8-25
<b>8-8</b>	<b>Co-inverter Communication</b> .....	<b>8-27</b>
8-8-1	Co-inverter Communication Parameters .....	8-28
8-8-2	Co-inverter Communication Settings.....	8-31
<b>8-9</b>	<b>Modbus Communication Data Lists</b> .....	<b>8-34</b>
8-9-1	Coil Number List.....	8-34
8-9-2	Register List .....	8-36

- 8-10 Command via Communications ..... 8-87**
  - 8-10-1 RUN Command via Communications..... 8-87
  - 8-10-2 Frequency Reference via Communications ..... 8-87
  - 8-10-3 Forced Commands via Communication ..... 8-88

## 8-1 Communications Specifications

The 3G3M1 Series Inverter has the RS-485-compliant Modbus communication function as standard, which enables communications with external network controllers. The basic specifications of this communications function are provided in the table below.

Item	Description	Remarks
Protocol	Modbus communication (Slave)	
Transmission speed	2,400, 4,800, 9,600, 19.2 k, 38.4 k, 57.6 k, 76.8 k, 115.2 kbps	Selectable via parameter
Synchronous system	Start-stop synchronous system	
Transmission code	Binary	
Transmission mode	LSB first (Transmission starts with Least Significant Bit)	
Compatible interface	RS-485	
Data bit length	8 bits	
Parity	No/Even/Odd	Selectable via parameter
Stop bit length	1 or 2 bits	Selectable via parameter
Startup method	One-side start by host command	-
Wait time	Silent interval 0.00 to 1.00 [s]	Selectable via parameter
Connection form	1: N (N = 247 max.) (32 units max. connectable without repeaters)	Selectable via parameter
Error check	Overrun/Framing/CRC-16/Horizontal parity	
Communications cable length	500 m	

# 8-2 RS-485 Terminal Arrangement and Connection

The communications terminals are arranged as follows.

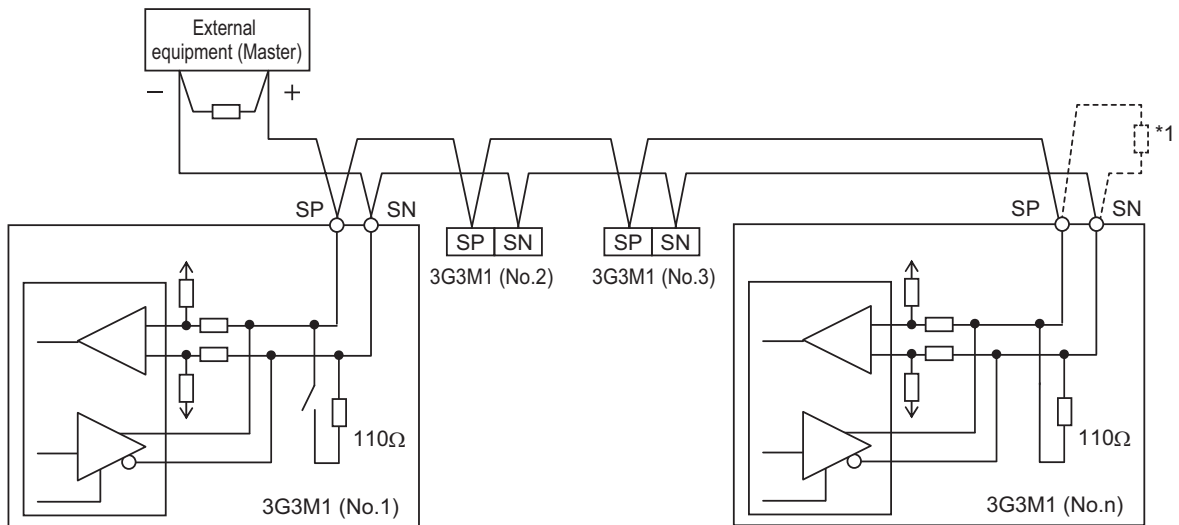
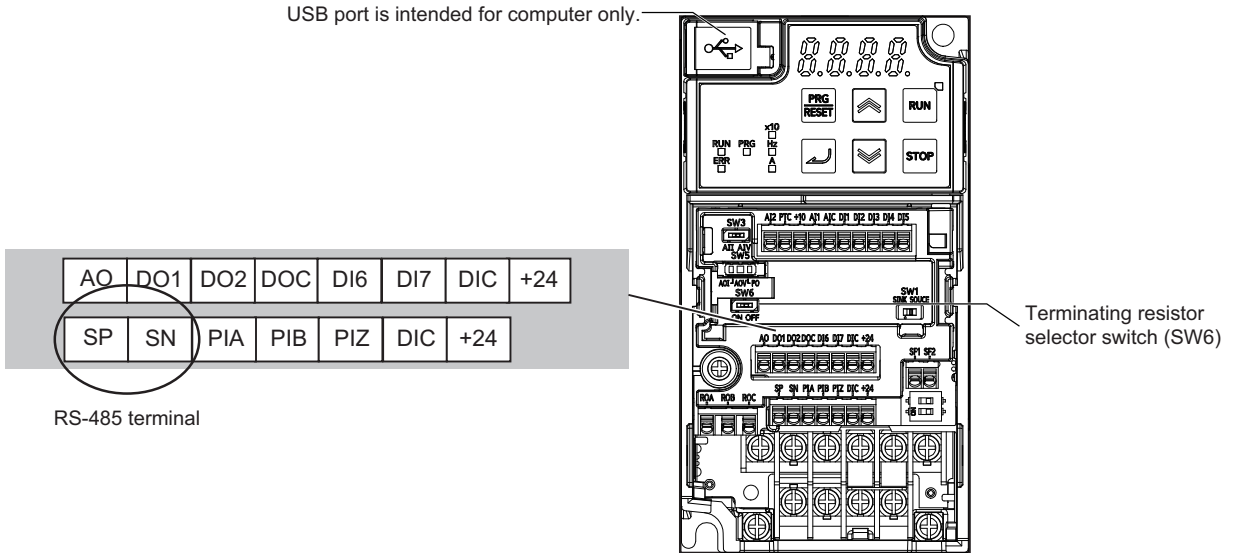

\*1. If the communications are unstable, install a terminating resistor appropriate to the impedance of the cable to each cable end. The resistance of the terminating resistor built into this inverter is 110 Ω.

## 8-3 Modbus Communication Parameters

Set the following parameters according to the communications specifications.

- To control the frequency reference or RUN command via Modbus communication, set the 1st Frequency Reference Selection (F01) or 2nd Frequency Reference Selection (C30) to “14: RS-485 communication,” and the 1st RUN Command Selection (F02) or 2nd RUN Command Selection (E102) to “4: RS-485 communication”.
- According to the communications specifications of the host, set the RS-485 Communication Baud Rate (y14), RS-485 Communication Parity Bit Selection (y16), RS-485 Communication Timeout Time (y18), and RS-485 Communication Response Interval Time (y19).
- In the RS-485 Communication Station No. Selection (y11), set the slave address of the inverter.
- If the communications with the host are interrupted for a period longer than the RS-485 Communication Timeout Time (y18), the inverter will detect a communications error. In the Operation Selection on Communication Error (y12), set how the inverter should operate if it detects a communications error.

When this parameter is set to 0, 1, 2, or 11 and tripped, you must reset the trip in order to resume the inverter control.

y12	Action at communications error
0: Immediately trip	Detects a Modbus communication error (ErP) and shuts off the output.
1: Trip after running for the period specified by timer	At communications error, this operates the inverter for the period specified by timer (y13), then displays a Modbus communication error (ErP) and stops operation.
2: Retry communications for the period specified by timer, and trip if communications are not restored. Continue running if communications are restored.	At communications error, retries communications for the period specified by timer (y13), and continues operation if communications are restored. If communications are not restored, this displays a Modbus communication error (ErP) and stops operation.
3: Continue to run	Ignores the communications error, and continues to run according to the current reference/command.
11: Trip after deceleration stop	Makes a deceleration stop and detects a Modbus communication error (ErP).
13: Free-run stop	Shuts off the output, but does not trip.
14: Deceleration stop	Makes a deceleration stop, but does not trip.

Parameter No.	Function name	Data	Default data	Unit
F01/C30	1st Frequency Reference Selection/2nd Frequency Reference Selection	14: RS-485 communication	0	-
F02/E102	1st RUN Command Selection/2nd RUN Command Selection	4: RS-485 communication	2	-

Parameter No.	Function name	Data	Default data	Unit
y14	RS-485 Communication Baud Rate	0: 2400 bps 1: 4800 bps 2: 9600 bps 3: 19200 bps 4: 38400 bps 5: 57600 bps 6: 76800 bps 7: 115200 bps	2	-
y11	RS-485 Communication Station No. Selection	1 to 255	1	-
y16	RS-485 Communication Parity Bit Selection	0: None (Stop bit: 2 bits) 1: Even number parity (Stop bit: 1 bits) 2: Odd number parity (Stop bit: 1 bits) 3: None (Stop bit: 1 bits)	3	-
y12	Operation Selection on Communication Error	0: Immediately trip with alarm ErP 1: Trip with alarm ErP after running for the period specified by timer y003 2: Retry during the period specified by timer y003. If the retry fails trip with alarm ErP. If it succeeds continue to run. 3: Continue to run 11: Trip with alarm ErP after deceleration stop 13: Free run stop 14: Deceleration stop	0	-
y18	RS-485 Communication Timeout Time	0: Not check of the time-out (OFF) 1 to 60 s	0.0	s
y19	RS-485 Communication Response Interval Time	0.00 to 1.00 s	0.01	s
y13	RS-485 Error Detection Timer	0.0 to 60.0 s	2.0	s
y97	Communication Data Storage Selection	0: Store into nonvolatile memory (Rewritable times are limited) 1: Write into temporary memory (Rewritable times are unlimited) 2: Save all data from temporary memory to nonvolatile memory (After all data is saved, return to Data 1)	1	-



## 8-4 Modbus Communication Protocol

The inverter communicates with external controllers as follows.

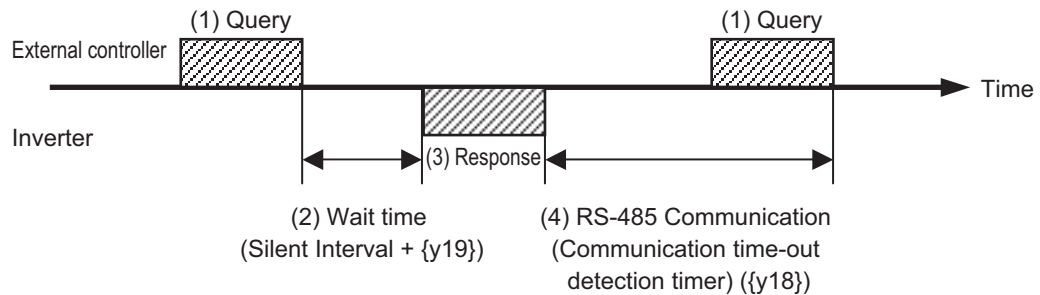

1. Frame (Query) that is sent from the external control device to the inverter
2. After receiving a query frame, the inverter waits the total time of the silent Interval and the RS-485 Communication Response Interval Time (y19), before returning a response.

Silent interval

The wait time that is specified on Modbus communication. Its data length is 3.5 characters (3.5 bytes).

It depends on the Modbus communication speed setting.

(Ex For 9,600 bps communications

am One character: 10 bits (1 start bit + 8 data bits + 1 stop bit)

ple Time required per character:  $1/9,600 \text{ (bps)} \times 10 \text{ (bit length)} \times 1,000 = 1.04 \text{ ms}$

) Time required for 3.5 characters:  $1.04 \text{ ms} \times 3.5 = 3.64 \text{ ms}$

However, according to the Modbus specifications, this time is fixed to 1.75 ms for communications speeds exceeding 19.2 kbps.

3. Frame (Response) that is sent from the inverter back to the external controller.
4. After sending a response, the inverter monitors the time until it completes receiving the query frame from the external control device. The inverter judges it as a communications error if it receives no response within the RS-485 Communication Timeout Time (y18). Then, the inverter operates according to the Operation Selection on Communication Error (y12), while waiting for the reception of the first data again. The monitoring of the Communication Error Timeout Time starts from the first sending/receiving operation is established after the power supply is cycled or after the inverter is reset. The inverter does not recognize as a communications error timeout if the sending/receiving operation is not established at all.

### 8-4-1 Message Configuration

The command message sent from the master to a slave (or slaves) is called a “query” and the response message returned from the slave(s) is called a “response.” The transmission format of a query/response is as follows.

Query	Response
Slave address	Confirmation slave address
Function code	Confirmation function code

Query	Response
Query data	Response data
Error check (CRC-16)	Error check (CRC-16)

## Slave Address

A slave address is a serial number from 1 to 247 set in advance for each inverter (slave). (Only the inverter that matches the slave address specified in the query will capture that query.)

### ● Simultaneous broadcast to up to five groups

Set the slave address to 0 to perform broadcasting (simultaneous broadcast).

In a broadcast, all slaves receive data, but they return no response to it.

Moreover, during a broadcast, this inverter cannot perform data read or loop-back operation.

Although the Modbus specifications define the slave addresses between 1 to 247, using the slave addresses 250 to 254 on the master side enables you to perform simultaneous broadcasting by group. (In this case, the slaves return no response.)

Please note that this function is enabled for write commands (function code: 05 hex, 06 hex, 0F hex, and 10 hex) only.

Slave address	Recipient
250 (FAh)	Simultaneous broadcast to slave addresses 01 to 09
251 (FBh)	Simultaneous broadcast to slave addresses 10 to 19
252 (FCh)	Simultaneous broadcast to slave addresses 20 to 29
253 (FDh)	Simultaneous broadcast to slave addresses 30 to 39
254 (FEh)	Simultaneous broadcast to slave addresses 40 to 247

## Function Code

A function code specifies the function to be performed by the target inverter(s).

The supported function codes are as shown in the table below.

### ● Function code

Function code	Function	Maximum number of data bytes per message	Maximum number of data per message
01 hex	Read Coil Status	10	80 coils (in bits)
03 hex	Read from Holding Register	200	100 registers (in bytes)
05 hex	Write to Coil	2	1 coil (in bits)
06 hex	Write to Holding Register	2	1 register (in bytes)
08 hex	Loop-back Test	-	-
0F hex	Write to Multiple Coils	2	16 coils (in bits)
10 hex	Write to Multiple Holding Registers	200	100 registers (in bytes)
17 hex	Read/Write from/to Multiple Holding Registers	32 each for read/write operation	16 registers each for read/write operation (in bytes)

## Data

A message sends data related to the function code.

The data transmission format differs depending on the function code.

Among the data used in Modbus communication, the 3G3M1 Series supports the following data types.

Data name	Description
Coil	Binary data (1 bit) that supports read/write operation
Holding register	16-bit data that supports read/write operation

## Error Check

In Modbus communication, CRC (Cyclic Redundancy Check) is used for error checking.

The CRC code is 16-bit data generated for any data block with a data length in 8-bit units.

For CRC code generation, the following generator polynomial is used: CRC-16 ( $X^{16} + X^{15} + X^2 + 1$ ).

### 8-4-2 Required Communications Time

The time that the inverter takes to send a response after receiving a query is the sum of the silent interval (3.5 characters) and the y19 (Communication Wait Time) set value.

After receiving a response from an inverter, be sure to include an interval equivalent to the silent interval (3.5 characters) or more before sending the next query to the inverter.

(Ex For 9,600 bps communications

am One character: 10 bits (1 start bit + 8 data bits + 1 stop bit)

ple Time required per character:  $1/9,600 \text{ (bps)} \times 10 \text{ (bit length)} \times 1,000 = 1.04 \text{ ms}$

) Time required for 3.5 characters:  $1.04 \text{ ms} \times 3.5 = 3.64 \text{ ms}$

However, according to the Modbus specifications, this time is fixed to 1.75 ms for communications speeds exceeding 19.2 kbps.

### 8-4-3 Normal Response

If the function code included in a query is for the Loop-back Test (08 hex), Write to Coil (05 hex, 0F hex), or Write to Holding Register(s) (06 hex, 10 hex) function, the inverter returns a response with the same content as that of the query.

If the function code included in a query is for the Read Coil Status (01 hex) or Read from Holding Register (03 hex) function, the inverter returns a response that includes data with the same slave address and function code.

Refer to the later section, *8-5 Explanation of Each Function Code* on page 8-11.

### 8-4-4 Abnormal Response

If an error (except for a communications error) is found in the query content, the inverter will return an exception response without performing any operation. Refer to the later section, *8-5-9 Exception Response* on page 8-20.

#### ● Response

Slave address

Function code
Exception code
Error check (CRC-16)

If an error (except for a communications error) is found in the query content, the inverter will return an exception response without performing any operation.

For the cause of an error, check the function code for the response. The function code for an exception response is the sum of the function code for the query and 80 hex (where the MSB is 1).

For the cause of an error, check the exception code.

### ● Exception code

Code	Description
01 hex	An unsupported function is specified.
02 hex	The specified address does not exist.
03 hex	Data to write is out of the allowable range for writing.
07 hex	<ul style="list-style-type: none"> <li>The inverter does not allow this function.</li> <li>During operation, function attempts to write while write disallowed or a function that cannot be written during operation.</li> <li>Function attempts to write to a write prohibited parameter during undervoltage. (Other than all S group parameters, E52, H99, H198, H199)</li> </ul>

### 8-4-5 No Response

The inverter will ignore the query and return no response if:

- It receives a broadcast (query with the address set to 0).
  - It detects a communications error in receiving a query.
  - The slave address specified in a query differs from the inverter's slave address setting.
  - The length of the time interval set for the inverter to receive the next data of the message after receiving a message is less than 3.5 characters.
  - The data length of a query is inappropriate.
  - The length of the reception interval in a frame exceeds 1.5 characters.
  - The error check code specified in a query does not match (CRC error).
  - It receives a simultaneous broadcast by group (query with the address set to 250 to 254).
  - It detects a parity error.
- Provide a timer on the master side for monitoring the response and set it to resend the same query if no response is received within the set time.

## 8-5 Explanation of Each Function Code

### 8-5-1 Read Coil Status [01 hex]

Reads the coil status (ON/OFF).

#### Example) Reading Data from Multifunction Input Terminals DI1 to DI7 of Inverter with Slave Address 1

The status of each multifunction input terminal is as follows.

Item	Data						
Coil No.	0003 hex	0004 hex	0005 hex	0006 hex	0007 hex	000E hex	000F hex
Multifunction input terminal	DI1	DI2	DI3	DI4	DI5	DI6	DI7
Coil status	ON	OFF	ON	OFF	OFF	OFF	ON

Coil numbers 0008 to 000D hex are a reserved area.

#### ● Query

No.	Field name	Example (hex)	Remarks
1	Slave address* <sup>1</sup>	01	
2	Function code	01	
3	Coil start address (MSB)* <sup>2</sup>	00	(Coil address) = (Coil number) - 1
4	Coil start address (LSB)* <sup>2</sup>	02	
5	Number of coils (MSB)	00	
6	Number of coils (LSB)	0C	
7	CRC-16 (MSB)	9D	
8	CRC-16 (LSB)	CF	

\*1. Broadcasting cannot be performed.

\*2. Note that the coil start address is 0002 hex, which is 1 less than the coil number 0003 hex: Coil start address = Coil number - 1.

#### ● Response

No.	Field name	Example (hex)	Remarks
1	Slave address* <sup>1</sup>	01	
2	Function code	01	
3	Number of data bytes	02	
4	Coil data 1* <sup>2</sup>	08	Input terminal D7, D6    Input terminal D5 to D1 ← 805 hex = 1000 0000 0101 Reserved
5	Coil data 2* <sup>2</sup>	05	
6	CRC-16 (MSB)	7E	

No.	Field name	Example (hex)	Remarks
7	CRC-16 (LSB)	3F	

\*1. Broadcasting cannot be performed.

\*2. Data as much as the number of data bytes will be transferred. The MSB (the first received data) has the smallest coil address.

The data received in a response shows the status for coils 0003 to 000F hex. Therefore, the received data "805 hex=1000 0000 0101" can be read, with the status for coil 0003 hex as the LSB, as described in "Response" on the previous page.

The received data is always transferred in 1-byte (8 bits) format. Bits that lack data are transferred as 0.

If the Read Coil Status function is not executed normally, refer to 8-5-9 *Exception Response* on page 8-20.

(Ex- When the status of 16 coils starting from coil number 0001 hex is read, the order of data is as shown am- below. Data 1 is the initial byte data to be sent. ple)

	bit 7	bit 6	bit 5	bit 4	bit 3	bit 2	bit 1	bit 0
Data 1	0008 hex	0007 hex	0006 hex	0005 hex	0004 hex	0003 hex	0002 hex	0001 hex
Data 2	0010 hex	000F hex	000E hex	000D hex	000C hex	000B hex	000A hex	0009 hex

## 8-5-2 Read from Holding Register [03 hex]

Reads the contents of only the specified number of consecutive holding registers from the specified holding register address.

### Example) Reading Latest Trip Data (0012 hex to 001B hex) from Inverter with Slave Address 1

#### ● Query

No.	Field name	Example (hex)	Remarks
1	Slave address*1	01	
2	Function code	03	
3	Register start address (MSB)*2	00	(Register address) = (Register number) - 1
4	Register start address (LSB)*2	11	
5	Number of holding registers (MSB)	00	10 registers
6	Number of holding registers (LSB)	0A	
7	CRC-16 (MSB)	C4	
8	CRC-16 (LSB)	08	

\*1. Broadcasting cannot be performed.

\*2. Note that the holding register start address is 0011 hex, which is 1 less than the register number 0012 hex: Register address = Register number - 1.

## ● Response

No.	Field name	Example (hex)	Remarks
1	Slave address*1	01	
2	Function code	03	
3	Number of data bytes*2	14	
4	Register data 1 (MSB)	00	0001 hex → 01 dec → OC1 Overcurrent protection (during acceleration)
5	Register data 1 (LSB)	01	
6	Register data 2 (MSB)	02	201 hex → 100000001 bin → FW: During forward operation, ACC: During acceleration
7	Register data 2 (LSB)	01	
8	Register data 3 (MSB)	00	4D2 hex → 1234 dec → 12.34 [Hz] (Frequency)
9	Register data 3 (LSB)	00	
10	Register data 4 (MSB)	04	
11	Register data 4 (LSB)	D2	
12	Register data 5 (MSB)	01	012C hex → 300 dec → 3.00 [A] (Current)
13	Register data 5 (LSB)	2C	
14	Register data 6 (MSB)	0B	0B18 hex → 2840 dec → 284.0 [V] (DC voltage)
15	Register data 6 (LSB)	18	
16	Register data 7 (MSB)	00	A hex → 10 dec → 10 [hex] (Cumulative running time)
17	Register data 7 (LSB)	00	
18	Register data 8 (MSB)	00	
19	Register data 8 (LSB)	0A	
20	Register data 9 (MSB)	00	A hex → 10 dec → 10 [hex] (Cumulative operation time)
21	Register data 9 (LSB)	00	
22	Register data 10 (MSB)	00	
23	Register data 10 (LSB)	0A	
24	CRC-16 (MSB)	F9	
25	CRC-16 (LSB)	14	

\*1. Broadcasting cannot be performed.

\*2. Data as much as the number of data bytes will be transferred. In this example, the inverter sends back data from 10 holding registers, which is 20 (14 hex) bytes.

### 8-5-3 Write to Coil [05 hex]

Writes to a single coil. The coil status changes as shown in the table below.

Data	Coil status	
	OFF to ON	ON to OFF
Written data (MSB)	FF hex	00 hex
Written data (LSB)	00 hex	00 hex

#### Example) Issuing Forward Run Command to Inverter with Slave Address 1

You need to set the Run command selection to communications (F02/E102=4).

The coil number for the forward run command is 0001.

### ● Query

No.	Field name	Example (hex)	Remarks
1	Slave address* <sup>1</sup>	01	
2	Function code	05	(Coil address) = (Coil number) - 1
3	Coil address (MSB)* <sup>2</sup>	00	
4	Coil address (LSB)* <sup>2</sup>	00	
5	Written data (MSB)	FF	OFF to ON: FF00 hex
6	Written data (LSB)	00	
7	CRC-16 (MSB)	8C	
8	CRC-16 (LSB)	3A	

\*1. For a broadcast, no response will be sent back.

\*2. Note that the coil address is 0000, which is 1 less than the coil number 0001: Coil address = Coil number - 1.

### ● Response

No.	Field name	Example (hex)
1	Slave address* <sup>1</sup>	01
2	Function code	05
3	Coil address (MSB)* <sup>2</sup>	00
4	Coil address (LSB)* <sup>2</sup>	00
5	Written data (MSB)	FF
6	Written data (LSB)	00
7	CRC-16 (MSB)	8C
8	CRC-16 (LSB)	3A

\*1. For a broadcast, no response will be sent back.

\*2. Note that the coil address is 0000, which is 1 less than the coil number 0001: Coil address = Coil number - 1.

If the Write to Coil function is not executed normally, refer to 8-5-9 *Exception Response* on page 8-20.

## 8-5-4 Write to Holding Register [06 hex]

Writes data to the specified holding register.

### Example) Writing 50.00 Hz to Inverter with Slave Address 1 as Output Frequency Setting Value (C99)

Because the holding registers for the Output Frequency Setting/Monitor (C99) have a data resolution of 0.01 Hz, to set 50.00 Hz, set the written data to 5000 (1388 hex).

### ● Query

No.	Field name	Example (hex)	Remarks
1	Slave address* <sup>1</sup>	01	
2	Function code	06	



No.	Field name	Example (hex)	Remarks
3	Register address (MSB)* <sup>2</sup>	12	(Register address) = (Register number) - 1
4	Register address (LSB)* <sup>2</sup>	16	
5	Written data (MSB)	13	1388 hex → 5000 dec → 50.00 Hz
6	Written data (LSB)	88	
7	CRC-16 (MSB)	60	
8	CRC-16 (LSB)	20	

\*1. For a broadcast, no response will be sent back.

\*2. Note that the holding register start address for C99(LOW) is 1216 hex, which is 1 less than the register number 1217 hex: Register address = Register number - 1.

## ● Response

No.	Field name	Example (hex)
1	Slave address* <sup>1</sup>	01
2	Function code	06
3	Register address (MSB)* <sup>2</sup>	12
4	Register address (LSB)* <sup>2</sup>	16
5	Written data (MSB)	13
6	Written data (LSB)	88
7	CRC-16 (MSB)	60
8	CRC-16 (LSB)	20

\*1. For a broadcast, no response will be sent back.

\*2. Note that the holding register start address for C99(LOW) is 1216 hex, which is 1 less than the register number 1217 hex: Register address = Register number - 1.

If the Write to Holding Register function is not executed normally, refer to 8-5-9 *Exception Response* on page 8-20.

### 8-5-5 Loop-back Test [08 hex]

Checks the communications between the master and the slave. Any value can be used for test data.

#### Example) Perform a Loop-back Test on Inverter with Slave Address 1

## ● Query

No.	Field name	Example (hex)
1	Slave address* <sup>1</sup>	01
2	Function code	08
3	Test sub code (MSB)	00
4	Test sub code (LSB)	00
5	Data (MSB)	Any
6	Data (LSB)	Any
7	CRC-16 (MSB)	CRC

No.	Field name	Example (hex)
8	CRC-16 (LSB)	CRC

\*1. Broadcasting cannot be performed.

## ● Response

No.	Field name	Example (hex)
1	Slave address*1	01
2	Function code	08
3	Test sub code (MSB)	00
4	Test sub code (LSB)	00
5	Data (MSB)	Any
6	Data (LSB)	Any
7	CRC-16 (MSB)	CRC
8	CRC-16 (LSB)	CRC

\*1. Broadcasting cannot be performed.

The test sub code supports the Echo Query Data command (00 hex, 00 hex) only. Other commands are not supported.

## 8-5-6 Write to Multiple Coils [0F hex]

Rewrites the ON/OFF status to consecutive multiple coils.

### Example) Changing Status of Multifunction Input Terminals DI1 to DI7 of Inverter with Slave Address 1

Change the ON/OFF status of the multifunction input terminal DI1 to DI7 as shown in the following table.

Item	Data						
Coil No.	0003 hex	0004 hex	0005 hex	0006 hex	0007 hex	000E hex	000F hex
Multifunction input terminal	DI1	DI2	DI3	DI4	DI5	DI6	DI7
Coil status	ON	ON	ON	OFF	ON	OFF	OFF

Coil numbers 0008 to 000D hex are a reserved area.

## ● Query

No.	Field name	Example (hex)	Remarks
1	Slave address*1	01	
2	Function code	0F	
3	Coil start address (MSB)*2	00	(Coil address) = (Coil number) - 1
4	Coil start address (LSB)*2	02	
5	Number of coils (MSB)	00	
6	Number of coils (LSB)	0C	
7	Number of bytes	02	

No.	Field name	Example (hex)	Remarks
8	Changed data (MSB) <sup>*3</sup>	17	Input terminal D7, D6    Input terminal D5 to D1  ← 17 hex = 0000 0001 0111 Reserved
9	Changed data (LSB) <sup>*3</sup>	00	
10	CRC-16 (MSB)	EB	
11	CRC-16 (LSB)	A2	

\*1. During a broadcast, no response will be sent back.

\*2. Note that the coil start address is 0002 hex, which is 1 less than the coil number 0003 hex: Coil start address = Coil number - 1.

\*3. Since written data occupies both MSB and LSB as a set, make the data have an even number of bytes by adding one byte of padding data, even if you actually need to change an odd number of bytes.

## ● Response

No.	Field name	Example (hex)
1	Slave address <sup>*1</sup>	01
2	Function code	0F
3	Coil start address (MSB) <sup>*2</sup>	00
4	Coil start address (LSB) <sup>*2</sup>	02
5	Number of coils (MSB)	00
6	Number of coils (LSB)	0C
7	CRC-16 (MSB)	F4
8	CRC-16 (LSB)	0E

\*1. During a broadcast, no response will be sent back.

\*2. Note that the coil start address is 0002 hex, which is 1 less than the coil number 0003 hex: Coil start address = Coil number - 1.

You can enable terminal commands using communications by enabling “4. RS-485 communication” in 1st RUN Command Selection (F02)/2nd RUN Command Selection (E102). If enabling terminal commands using RS-485 communications, refer to 7-2-1 *Multifunction Input Selection* on page 7-26 for the enable/disable relationship with the terminal block.

Multifunction input is monitored using a control circuit terminal for terminal block input (I/O) (monitor mode 4\_00), and communications control signal for communications input (I/O) (monitor mode 4\_01).

If the Write to Multiple Coils function is not executed normally, refer to 8-5-9 *Exception Response* on page 8-20.

(Ex- When the status of coils from coil number 0001 to 000D hex is written, the order of data is as shown am- below. Data 1 is the initial byte data to send. ple)

	bit 7	bit 6	bit 5	bit 4	bit 3	bit 2	bit 1	bit 0
Data 1	0008 hex	0007 hex	0006 hex	0005 hex	0004 hex	0003 hex	0002 hex	0001 hex
Data 2	-	-	-	000D hex	000C hex	000B hex	000A hex	0009 hex

### 8-5-7 Write to Multiple Holding Registers [10 hex]

Writes data to consecutive multiple holding registers.

#### Example) Writing 10 Seconds to Inverter with Slave Address 1 as 1st Acceleration Time 1 (F07) Value

Because the holding registers 1103 to 1104 hex for the 1st Acceleration Time 1 (F07) has a data resolution of 0.01 s, to set 10 seconds, set the written data to 1000 (0000 03E8 hex).

#### ● Query

No.	Field name	Example (hex)	Remarks
1	Slave address*1	01	
2	Function code	10	
3	Register start address (MSB)*2	11	(Register address) = (Register number) - 1
4	Register start address (LSB)*2	02	
5	Number of registers (MSB)	00	
6	Number of registers (LSB)	02	
7	Number of bytes*3	04	
8	Written data 1 (MSB)	00	0000 03E8 hex → 1000 dec → 10.00 s
9	Written data 1 (LSB)	00	
10	Written data 2 (MSB)	03	
11	Written data 2 (LSB)	E8	
12	CRC-16 (MSB)	B2	
13	CRC-16 (LSB)	98	

\*1. During a broadcast, no response will be sent back.

\*2. Note that the holding register start address is 1102 hex, which is 1 less than the register number 1103 hex: Register starting address = Register number - 1.

\*3. This is not the number of holding registers, but the number of bytes to be changed actually.

#### ● Response

No.	Field name	Example (hex)
1	Slave address*1	01
2	Function code	10
3	Register start address (MSB)*2	11
4	Register start address (LSB)*2	02
5	Number of registers (MSB)	00
6	Number of registers (LSB)	02
7	CRC-16 (MSB)	E5
8	CRC-16 (LSB)	34

\*1. During a broadcast, no response will be sent back.

\*2. Note that the holding register start address is 1102 hex, which is 1 less than the register number 1103 hex: Register starting address = Register number - 1.

If the Write to Multiple Holding Registers function is not executed normally, refer to 8-5-9 *Exception Response* on page 8-20.

## 8-5-8 Read/Write from/to Multiple Holding Registers [17 hex]

Reads data from and writes data to consecutive multiple holding registers in a continuous manner.

### Example) Writing 50.00 Hz to Output Frequency Setting/Monitor (C99) and Reading from Output Frequency Monitor before Slip Compensation (W03) Value from Inverter with Slave Address 1

Because the holding registers 1216 to 1217 hex for the Output Frequency Setting/Monitor (C99) have a data resolution of 0.01 Hz, to set 50.00 Hz, set the written data to 5000 (0000 1388 hex).

Similarly, the holding registers for the Output Frequency Monitor before Slip Compensation (W03) are 5245 to 5246 hex.

#### ● Query

No.	Field name	Example (hex)	Remarks
1	Slave address* <sup>1</sup>	01	
2	Function code	17	
3	Read register start address (MSB)* <sup>2</sup>	52	(Register address) = (Register number) - 1
4	Read register start address (LSB)* <sup>2</sup>	44	
5	Number of read registers (MSB)	00	
6	Number of read registers (LSB)	02	
7	Write register start address (MSB)* <sup>2</sup>	12	(Register address) = (Register number) - 1
8	Write register start address (LSB)* <sup>2</sup>	15	
9	Number of write registers (MSB)	00	
10	Number of write registers (LSB)	02	
11	Number of written data bytes n	04	
12	Written data 1 (MSB)	00	0000 1388 hex → 5000 dec → 50.00 Hz
13	Written data 1 (LSB)	00	
14	Written data 2 (MSB)	13	
15	Written data 2 (LSB)	88	
16	CRC-16 (MSB)	E8	
17	CRC-16 (LSB)	67	

\*1. Broadcasting cannot be performed.

\*2. Note that the holding register start address is 1 less than the register number: Register address = Register number - 1.

#### ● Response

No.	Field name	Example (hex)	Remarks
1	Slave address* <sup>1</sup>	01	
2	Function code	17	
3	Number of read data bytes n	04	
4	Read data 1 (MSB)	00	0000 1388 hex → 5000 dec → 50.00 Hz
5	Read data 1 (LSB)	00	
6	Read data 2 (MSB)	13	
7	Read data 2 (LSB)	88	
8	CRC-16 (MSB)	F4	

No.	Field name	Example (hex)	Remarks
9	CRC-16 (LSB)	71	

\*1. Broadcasting cannot be performed.

If the Read/Write from/to Multiple Holding Registers function is not executed normally, refer to 8-5-9 *Exception Response* on page 8-20.

### 8-5-9 Exception Response

In a query, the master requests a response, except for broadcast or simultaneous broadcast by group. Although the inverter normally returns a response to the query, it returns an exception response if the query has an error.

An exception response has the field configuration shown in the table below.

Field configuration
Slave address
Function code
Exception code
Error check

The details of the field configuration are as shown below. An exception response has a function code, which is the sum of the function code value of the query and 80 hex. An exception code shows the cause of the exception response.

Function code	
Query	Exception response
01 hex	81 hex
03 hex	83 hex
05 hex	85 hex
06 hex	86 hex
0F hex	8F hex
10 hex	90 hex
17 hex	97 hex

The MSB is 1.

Exception code	Description
01 hex	An unsupported function is specified.
02 hex	The specified address does not exist.
03 hex	Data to write is out of the allowable range for writing.
07 hex	<ul style="list-style-type: none"> <li>The inverter does not allow this function.</li> <li>During operation, function attempts to write while write disallowed or a parameter that cannot be written during operation.</li> <li>Function attempts to write to a write prohibited parameter during undervoltage. (Other than all S group parameters, E52, H99, H198, H199)</li> </ul>

## 8-6 Saving a Change to Holding Register (Enter Command)

The Write to Holding Register (06 hex) or Write to Consecutive Holding Registers (10 hex or 17 hex) function is used to enable new register data. However, the new data is not stored in the EEPROM memory of the inverter and is restored to the previous value when the inverter power supply is shut off. To store a change to holding registers in the inverter's EEPROM memory, issue the Enter command according to the following procedure. In addition, after changing a control parameter, you need to recalculate the motor parameters. In this case, also use the Enter command to execute recalculation.

### 8-6-1 How to Issue Enter Command

Use the Write to Holding Register (06 hex) command to write data to the holding register for the Enter command (0900 hex). Below are the values to be written to the holding register (0900 hex).

Set value	Description
0000	Disable
0001	Set values are stored in the EEPROM memory. This register automatically returns to 0.

### Example) Issuing Enter Command (Storing Set Value) for Inverter with Slave Address 8

#### ● Query

No.	Field name	Example (hex)	Remarks
1	Slave address <sup>*1</sup>	08	
2	Function code	06	
3	Register address (MSB) <sup>*2</sup>	08	(Register address) = (Register number) - 1
4	Register address (LSB) <sup>*2</sup>	FF	
5	Written data (MSB)	00	
6	Written data (LSB)	01	
7	CRC-16 (MSB)	7A	
8	CRC-16 (LSB)	C3	

\*1. For a broadcast, no response will be sent back.

\*2. Note that the register address is 08FF hex, which is 1 less than the register number 0900 hex.



#### ● Response

No.	Field name	Example (hex)
1	Slave address	08
2	Function code	06
3	Register address (MSB) <i>Response on page 8-21</i>	08
4	Register address (LSB) <i>Response on page 8-21</i>	FF
5	Written data (MSB)	00
6	Written data (LSB)	01

No.	Field name	Example (hex)
7	CRC-16 (MSB)	7A
8	CRC-16 (LSB)	C3

\*1. Note that the register address is 08FF hex, which is 1 less than the register number 0900 hex.

## 8-6-2 EEPROM Write Mode

- To set the EEPROM write mode, use the Write to Holding Register (06 hex) command etc. to write 1 to the holding register for the EEPROM write mode (0902 hex).
- In the EEPROM write mode, the data changed by the Write to Holding Register (06 hex) command is written to both the RAM (volatile memory for operation) and the EEPROM (non-volatile memory for storage). Then, the EEPROM write mode is canceled.
- The EEPROM write mode is canceled also if a command other than the Write to Holding Register (06 hex) command is received in the EEPROM write mode.
- If a continuous write command is received from Write to Multiple Holding Registers (10 hex) or Read/Write from/to Multiple Holding Registers (17 hex) in the EEPROM write mode, data writing will be accepted, but not written to EEPROM.
- When Sysmac Studio is connected online while in the EEPROM write mode, the EEPROM write mode is canceled.
- If "0: Save to non-volatile memory" is set in Communication Data Storage Selection (y97), this will always operate corresponding to EEPROM write mode regardless of this register.
- To change parameter y97, the "STOP key +  /  keys" must be pressed simultaneously.

### ● Difference between enter command and EEPROM write mode

#### Enter command

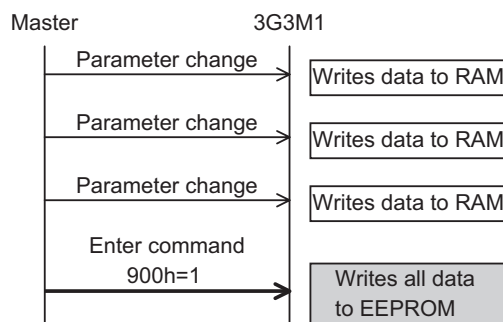

#### EEPROM write mode

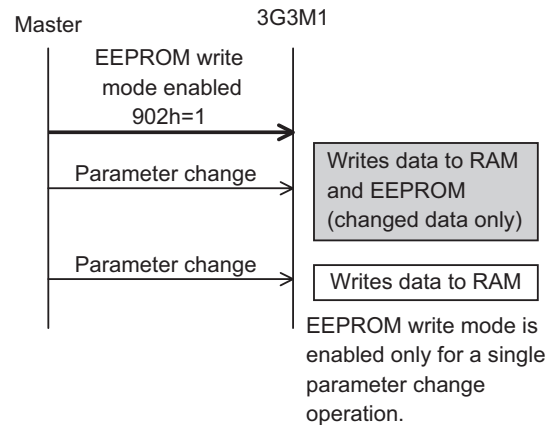



## 8-7 Modbus Mapping Function

This Modbus mapping function can change up to 10 register addresses.

For example, when designing replacements, you can match the inverter-side register addresses without changing the communications program.

It is also possible to set the data type, scale, and endian (byte order) of communication data according to your application.

### 8-7-1 Operation of Modbus Mapping Function

The Modbus mapping function can set up to 10 register addresses.

This function processes the command, which is sent to the external register address specified from the external communications, for data in the address set in the internal register.

Even if the data are different between the external and internal registers, it is possible to adjust this using data types and scaling settings.

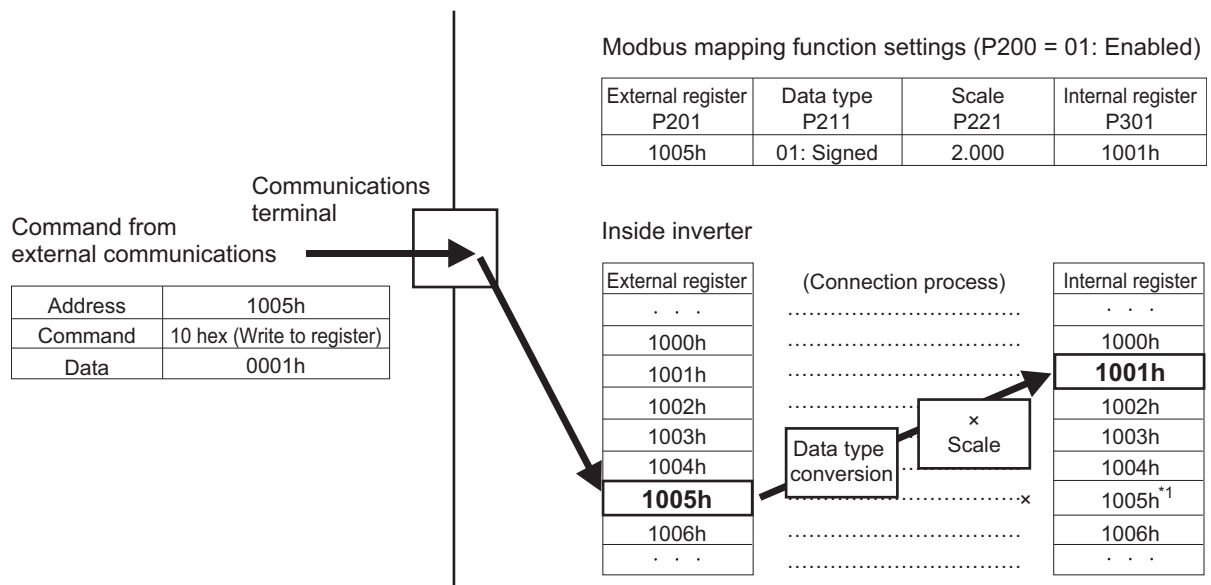

\*1. The internal register (Modbus register inside the inverter) that overlaps with the external register setting is disabled.

To use that internal register, set an external register not to overlap or set a different Modbus mapping function to access from a different register address.

### 8-7-2 Modbus Mapping Function Settings

To use the Modbus mapping function, set the Modbus Mapping Function Selection (H355) to "01: Modbus mapping function enabled" and set each parameter.

- Each number of 1 to 10 in Modbus Mapping External Register, Modbus Mapping External Register Type, Modbus Mapping Scaling, and Modbus Mapping Internal Register corresponds to one set of Modbus mapping function settings, respectively.
- In the Modbus Mapping 1 External Register to Modbus Mapping 10 External Register (H356 to H365), set the register address to receive commands from external communications.
- In the Modbus Mapping 1 External Register Sign to Modbus Mapping 10 External Register Sign (H366 to H375), set the data type used for the external register on the external communications

side. When this is set to “0: Unsigned,” the input value is limited to -32768 to 32767, and when set to “1: Signed,” the input value is limited to 0 to 65535.

- In the Modbus Mapping 1 Scaling to Modbus Mapping 10 Scaling (H376 to H385), set the scale factor for receiving data from external communications and capturing it into the inverter. Conversely, each of these settings provides a subtraction factor when internal data is output to external communications.
- In the Modbus Mapping 1 Internal Register to Modbus Mapping 10 Internal Register (H386 to H395), set the Modbus register address inside the inverter to process commands from external communications.

For the Modbus register addresses of the inverter, refer to *8-9 Modbus Communication Data Lists* on page 8-34.

- The Modbus mapping function is intended for 16-bit single-word and double-word data. It does not support coils. For double-word data writing, refer to *8-7-3 Writing to Double-word Data* on page 8-25.
- After setting or changing the Modbus mapping function, be sure to cycle the inverter power supply. Until the power supply is cycled, the inverter does not apply the changes to the Modbus mapping function settings.
- If the Modbus communication function is executed with any erroneous Modbus mapping function setting, the inverter will return an exception response to the command. In this case, check the exception code for the exception response.

For details on exception codes, refer to *8-7-4 Troubleshooting for Modbus Mapping Function* on page 8-25.

Parameter No.	Function name	Data	Default data	Unit
H355	Modbus Mapping Function Selection	0: Standard 1: Free mapping	0	-
H356 to H365	Modbus Mapping 1 External Register to Modbus Mapping 10 External Register	0000 to FFFF Hex	0000 hex	-
H366 to H375	Modbus Mapping 1 External Register Sign to Modbus Mapping 10 External Register Sign	0: Unsigned 1: Signed	0	-
H376 to H385	Modbus Mapping 1 Scaling to Modbus Mapping 10 Scaling	0.001 to 65.53 <sup>*1</sup>	1.000	-
H386 to H395	Modbus Mapping 1 Internal Register to Modbus Mapping 10 Internal Register	0000 to FFFF Hex	0000 hex	-
H396	Modbus Mapping Endian Selection	0: Big endian 1: Little endian 2: Special endian	0	-

\*1. H376 to H385 can only be displayed and set by the Digital Operator to within a range of 0.001 to 65.53. 0.001 to 65.535 can only be set when using communications.

### 8-7-3 Writing to Double-word Data

The Modbus mapping function also supports double-word data. When writing to double-word data, access the high word and the low word simultaneously. Accessing these separately will result in the following.

- Access to only the high word: An abnormal response, returning an exception code 02 hex (invalid address).
- Access to only the low word: Writing data to the low word only. High word data will not be changed.

### 8-7-4 Troubleshooting for Modbus Mapping Function

If there is any setting error for the Modbus mapping function, the inverter will display an exception response during Modbus communication.

In this case, check the exception code for the exception response.

Below are exception codes associated with exception response and the Modbus mapping function setting errors.

For details on other exception codes, refer to *8-5-9 Exception Response* on page 8-20.

#### ● Exception response for erroneous setting

The function code for an exception response is the sum of the executed function code and 80 hex. Check the error condition with the exception code.

#### ● Response

Slave address
Function code
Exception code
Error check (CRC-16)

Exception code	Error condition	Countermeasure
31 hex	• The Modbus mapping external register is set to other than 0000 and the Modbus mapping internal register address is not changed from 0000.	• Set the Modbus mapping external register.
	• The Modbus mapping internal register setting parameter does not exist.	• Set the Modbus mapping internal register correctly.
	• The Modbus mapping external register overlaps.	• Set the Modbus mapping external register so that it does not overlap.

### 8-7-5 Endian Function

In communications, endian refers to the byte order in single-word communications data to be sent/received.

Generally, big endian (where the MSB-side byte is stored first) and little endian (where the LSB-side byte is stored first) are used.

Special endian is a kind of big endian where the word order of double-word data is reversed. For the 3G3M1 Series Inverter, Modbus communication is configured in big endian.

The endian function can set endian only for data sent/received in communications (without changing the address).

In the Modbus Mapping Endian Selection (H396), set the endian you want to use.

The Modbus Mapping Endian Selection H396 setting is enabled independent of the Modbus Mapping Function Selection (H355) setting.

Parameter No.	Function name	Data	Default data	Unit
H396	Modbus Mapping Endian Selection	0: Big endian 1: Little endian 2: Special endian	0	-

### ● Byte order of single-word data

- Relationship between single-word data bits and bytes

Bit	8 to 15	7 to 0
Byte	MSB byte	LSB byte

- Order of data during Modbus communication

Send/Receive byte order	Big endian	Little endian	Special endian
1	MSB byte	LSB byte	MSB byte
2	LSB byte	MSB byte	LSB byte

### ● Byte order of double-word data

- Relationship between double-word data bits and bytes

Bit	24 to 31	16 to 23	8 to 15	7 to 0
Byte	MSB byte	Data 1	Data 2	LSB byte

- Order of data during Modbus communication

Send/Receive byte order	Big endian	Little endian	Special endian
1	MSB byte	LSB byte	Data 2
2	Data 1	Data 2	LSB byte
3	Data 2	Data 1	MSB byte
4	LSB byte	MSB byte	Data 1

### ● Executable function codes

This function is enabled only for the function codes listed below.

Other function codes will be processed in big endian.

Function code	
03 hex	Read from multiple holding registers
06 hex	Write to a holding register
10 hex	Write to multiple holding registers
17 hex	Read/Write from/to multiple holding registers

## 8-8 Co-inverter Communication

In addition to the standard Modbus communication (slave), the 3G3M1 Series Inverter provides the co-inverter communication function, which enables more than one 3G3M1 Series Inverter to communicate mutually without master equipment such as a computer or PLC.

In co-inverter communication, the inverters are assigned as “management inverter,” “master inverter,” and “slave inverter.” The master inverter is specified by the management inverter according to the user settings. The others are slave inverters. The management inverter is always fixed, but the master inverter is switched sequentially. Therefore, the management inverter may serve as the master or a slave inverter. Other conditions are as follows.

- One management inverter is required within a network.
- Up to eight inverters can serve as the master inverter.
- Up to 247 inverters can be connected within the entire network (32 inverters without repeaters in compliance with the RS-485 specifications).

In co-inverter communication, be sure to assign the station No. 1, which serves as the management inverter.

The master inverter can write data to the holding registers on any slave inverter. At this time, up to five different station numbers and holding registers can be specified at once. On completion of each data transmission session between the master and a slave (or slaves), the master inverter is switched to the next in a sequential manner. In this way, data transmission is repeated according to the settings for each master inverter.

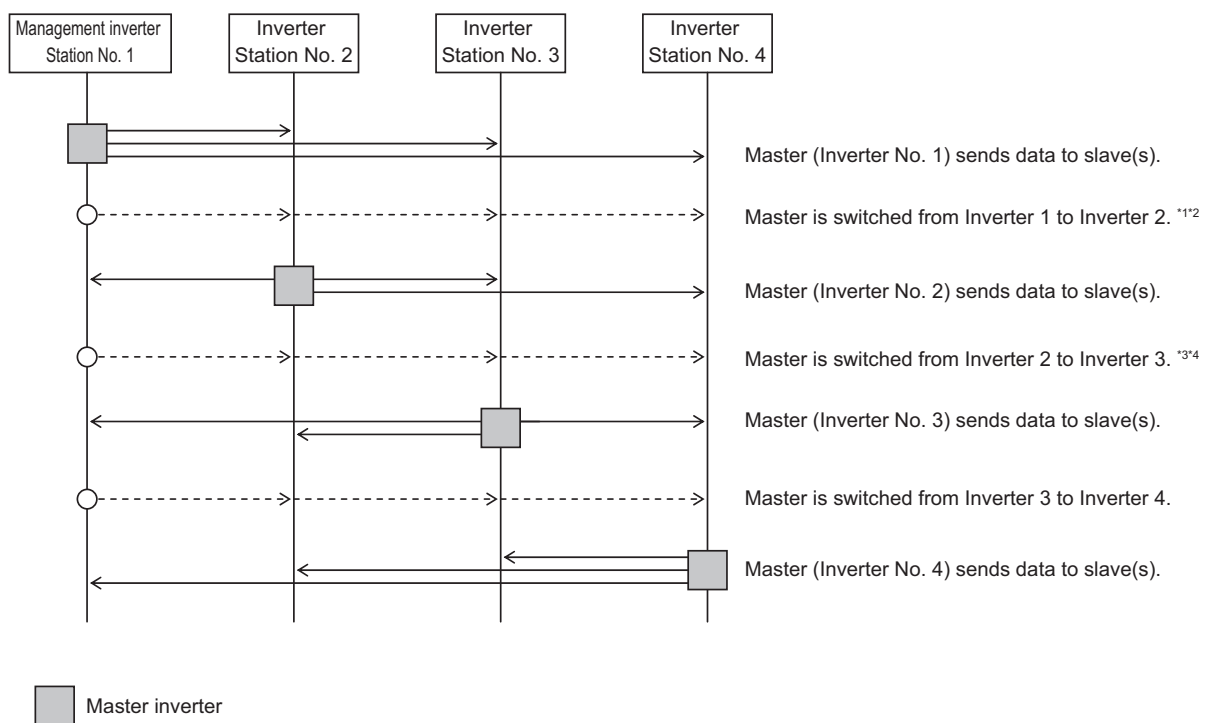

\*1. Switching of the master inverter is performed automatically by the management inverter.

\*2. The management inverter sends the master switching command from Inverter No. 01 to 02 after data is sent from Inverter 01 (master) to a slave (or slaves), with a wait time of “silent interval + Communication Wait Time (y19).”

- \*3. After receiving data from the master inverter, the management inverter sends the next master switching command with a wait time of “silent interval + Communication Wait Time (y19).” If the management inverter cannot receive the data sent from the master inverter within the Communication Error Timeout Time (y18), a communication timeout occurs and the management inverter follows the operation set in the Operation Selection on Communication Error (y12).
- \*4. Be sure to enable the Communication Error Timeout Time setting (y18 = 0.01 to 99.99) on the management inverter. When this setting is disabled (y18 = 0), the co-inverter communication will stop if the management inverter cannot receive data from the master inverter. In this case, cycle the power supply for the management inverter, or reset the management inverter (by turning ON/OFF the terminal RS).

### 8-8-1 Co-inverter Communication Parameters

The parameters required to establish co-inverter communication are shown in the table below.

Parameter No.	Function name	Data	Default data	Unit	Setting target*1
y11*2	RS-485 Communication Station No. Selection	1 to 255*3 (250 to 255: Simultaneous broadcasting by group)	1	-	ALL*4
y12*5	Operation Selection on Communication Error	0: Immediately trip with alarm ErP 1: Trip with alarm ErP after running for the period specified by timer y003 2: Retry during the period specified by timer y003. If the retry fails trip with alarm ErP. If it succeeds continue to run. 3: Continue to run 11: Trip with alarm ErP after deceleration stop 13: Free run stop 14: Deceleration stop	0	-	ALL
y13	RS-485 Error Detection Timer	0.0 to 60.0 s	2.0	s	ALL
y14	RS-485 Communication Baud Rate	0: 2400 bps 1: 4800 bps 2: 9600 bps 3: 19200 bps 4: 38400 bps 5: 57600 bps 6: 76800 bps 7: 115200 bps	2	-	ALL
y16	RS-485 Communication Parity Bit Selection	0: None (Stop bit: 2 bits) 1: Even number parity (Stop bit: 1 bits) 2: Odd number parity (Stop bit: 1 bits) 3: None (Stop bit: 1 bits)	3	-	ALL
y18	RS-485 Communication Timeout Time	0: Not check of the time-out (OFF) 1 to 60 s	0.0	s	ALL

Parameter No.	Function name	Data	Default data	Unit	Setting target*1
y19	RS-485 Communication Response Interval Time	0.00 to 1.00 s	0.01	s	ALL
H303*2	Co-Inverter Communication Function Selection	0: Disable 1: Enable 2: Enable (administrator)	0	-	- B*6 A
H304*2	Co-inverter Communication Starting Station Number (Administrator)	1 to 8 Need to be set in administrator(H303=2)*7	1	-	A
H305*2	Co-inverter Communication Ending Station Number (Administrator)	1 to 8 Need to be set in administrator(H303=2)*7	1	-	A
H306*2	Co-inverter Communication Start Selection (Administrator)	0: Start via RS-485 terminal*8 1: Always ON*9 Need to be set in administrator(H303=2)	0	-	A
H339	Number of Sent Data of All Stations in Co-inverter Communication	1 to 5	5	-	M
H340	Recipient Station Number of All Stations in Co-inverter Communication 1	1 to 247*10	1	-	M
H341	Recipient Register of All Stations in Co-inverter Communication 1	0000 to FFFF Hex	0000	-	M
H342	Sender Register of All Stations in Co-inverter Communication 1	0000 to FFFF Hex	0000	-	M
H343	Recipient Station Number of All Stations in Co-inverter Communication 2	1 to 247*10	2	-	M
H344	Recipient Register of All Stations in Co-inverter Communication 2	0000 to FFFF Hex	0000	-	M
H345	Sender Register of All Stations in Co-inverter Communication 2	0000 to FFFF Hex	0000	-	M
H346	Recipient Station Number of All Stations in Co-inverter Communication 3	1 to 247*10	3	-	M

Parameter No.	Function name	Data	Default data	Unit	Setting target*1
H347	Recipient Register of All Stations in Co-inverter Communication 3	0000 to FFFF Hex	0000	-	M
H348	Sender Register of All Stations in Co-inverter Communication 3	0000 to FFFF Hex	0000	-	M
H349	Recipient Station Number of All Stations in Co-inverter Communication 4	1 to 247*10	4	-	M
H350	Recipient Register of All Stations in Co-inverter Communication 4	0000 to FFFF Hex	0000	-	M
H351	Sender Register of All Stations in Co-inverter Communication 4	0000 to FFFF Hex	0000	-	M
H352	Recipient Station Number of All Stations in Co-inverter Communication 5	1 to 247*10	5	-	M
H353	Recipient Register of All Stations in Co-inverter Communication 5	0000 to FFFF Hex	0000	-	M
H354	Sender Register of All Stations in Co-inverter Communication 5	0000 to FFFF Hex	0000	-	M
E01 to E05, E98, E99	Input Terminal [DI1] Function Selection to Input Terminal [DI7] Function Selection	160: 485 (Start co-inverter communication)*8	-	-	A

\*1. Below are the details of the setting target.

ALL: Setting required for all connected inverters

A: Setting required only for management inverter (Station No. 1)

B: Setting required for inverters other than management inverter (Station No. 1)

M: Setting required only for inverters set in H304 to H305 (= Inverters assigned with master role)

\*2. After changing any of the y11 and H303 to H306 data on the management inverter, be sure to cycle the power supply to apply the changes. For inverters other than the management inverter, these changes will be applied immediately. However, for inverters other than the management inverter, if y11 is changed to Station No. 1 (Management Inverter), be sure to cycle the power supply to apply the changes. (Station Nos. 2 to 247 will apply changes immediately.)

\*3. To switch the master inverter among more than one inverter, be sure to set sequential station numbers. If the set station numbers include any skipped number, communications cannot be established.

\*4. For the management inverter, set the station number to 1 (y11 = 1).

\*5. When the Operation Selection on Communication Error (y12) is set to other than "3: Continue to run" on the management inverter, the co-inverter communication session will stop if a communications timeout error occurs on the management inverter. In this case, cycle the power supply of the management inverter.

\*6. When Co-Inverter Communication Function Selection (H303) is set to "1: Co-inverter communication" or "2: Co-inverter communication (Management Inverter)," co-inverter communication will be possible.

\*7. Set these parameters so that H304 is equal to or less than H305.



- \*8. When the Co-inverter Communication Start Selection (H306) is set to “0: Start via 485 terminal,” set one of the Input Terminal [DI1] Function Selection to Input Terminal [DI7] Function Selection (E01 to E05, E98, E99) to “160: 485 (Start co-inverter communication).”
- \*9. When the Co-inverter Communication Start Selection (Administrator) (H306) is set to “1: Constant communication,” the management inverter starts sending data as soon as the power supply is turned on. At this time, if the next master inverter is delayed in the startup and cannot receive the master switching command, the master inverter cannot send the data, which results in a communications timeout error on the management inverter. When you set H306 to 1, check that the startup of other inverters is completed and power on the management inverter finally.
- \*10. Although, in master-to-slave communications, you set recipient slave's station number, actually, data is sent to all stations via broadcast communications (Station No. 0). Slaves that are not specified as the recipient on the master side discard the received data.

## 8-8-2 Co-inverter Communication Settings

- On each inverter, set the station number (y11) so that they do not overlap among the inverters. Do not forget to set the station No. 1, which serves as the management inverter.
- On the management inverter, set the Co-Inverter Communication Function Selection (H303) to “2: Active EzCOM (administrator).” For other inverters, set the Co-Inverter Communication Function Selection (H303) to “1: Active EzCOM” or “2: Active EzCOM (administrator).”
- Set a station number 1 to 8 on inverters that serve as the master inverter. To switch the master inverter among more than one inverter, the station numbering must be sequential. On the management inverter, set the smallest master station number in the Co-inverter Communication Starting Station Number (Administrator) (H304) and the largest master station number in the Co-inverter Communication Ending Station Number (Administrator) (H305).
- In the Co-inverter Communication Start Selection (H306), set how to start inverter communications. When “0: Input terminal[DI1] to [DI8] Co-inverter communication start (485)” is selected for Co-inverter Communication Start Selection (Administrator) (H306), allocate “160: 485 (Start co-inverter communication)” to one of the Input Terminal [DI1] Function Selection to Input Terminal [DI7] Function Selection (E01 to E05, E98, E99).
- In H339 to H354, set the following parameters, which are required when the master inverter writes data: the number of sent data, recipient station number, recipient register address, and sender register address.

### Co-inverter Communication Operation

1. **The master inverter sends data to one or more slave inverters according to the settings for that master inverter.**  
(This data is also sent to the management inverter that does not serve as the master inverter.)
2. **The management inverter sends the master switching command and the master inverter is switched accordingly.**
3. **The next master inverter sends data to one or more slave inverters in the same manner as explained in step (1).**  
(This data is also sent to the management inverter that does not serve as the master inverter.)
4. **Steps (2) and (3) are followed repeatedly.**

**Note** Because this inverter is designed to establish co-inverter communication as broadcast communications (Station No. 0), communications data is sent to all stations. Therefore, slaves that are not specified as the recipient on the master side receive the data once, but discard internally the data not addressed to them.

## Example of Co-inverter Communication Sequence

The sequence diagram below shows co-inverter communication among four inverters with station numbers from 1 to 4, where Stations No. 1 to 3 are set as the master inverter.

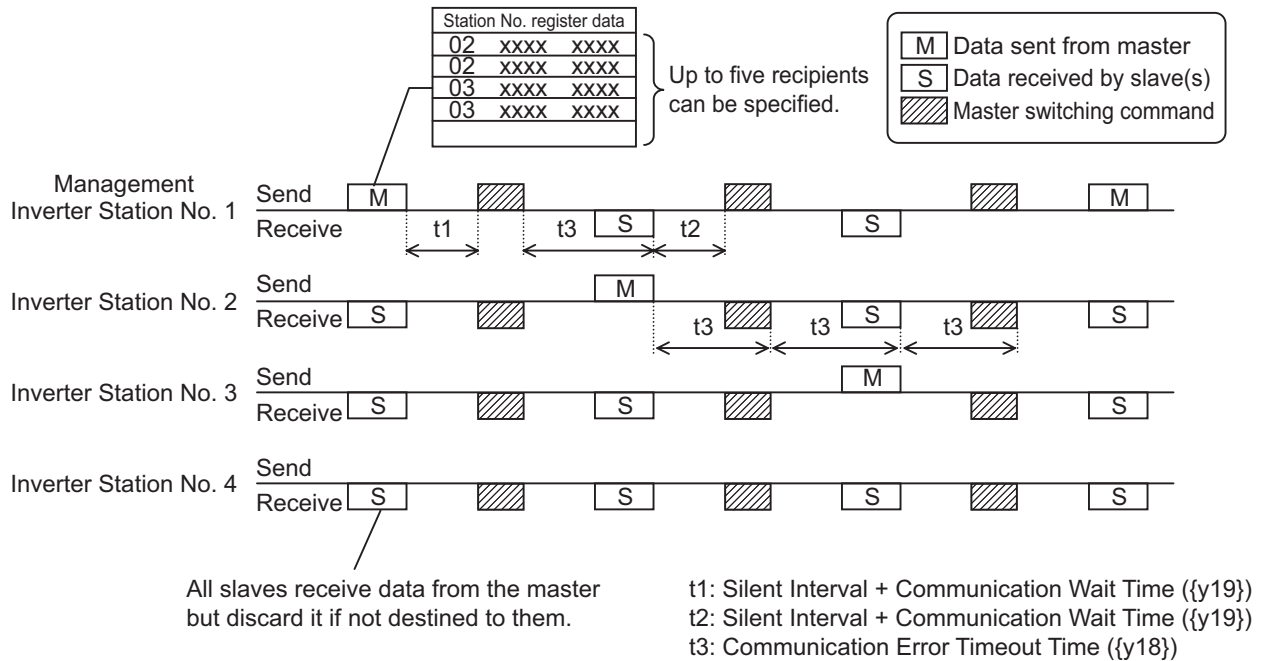

- Be sure to set the RS-485 Communication Timeout Time (y18) to other than 0.00 (one second or longer is recommended) on the management inverter. When this parameter is set to 0.00, the inverter's communications function will stop if no data is received from the master inverter. If it stops working, cycle the power supply of the management inverter.
- The communications error timeout timer starts when the inverter starts waiting for data reception and times out when it cannot complete data reception within the set time. If a timeout occurs, the inverter performs the operation set in the Operation Selection on Communication Error (y12). (t3 in above diagram)
- When the management inverter is the master, the master switching command will be sent with a wait time of silent interval + RS-485 Communication Response Interval Time (y19) after the master inverter sends data. (t1 in above diagram)
- When an inverter other than the management inverter is the master, the master switching command will be sent with a wait time of silent interval + RS-485 Communication Response Interval Time (y19) after receipt of data sent from the master inverter. (t2 in above diagram)
- When the Co-inverter Communication Start Selection is set to "1: Constant communication," the management inverter starts sending data as soon as the power supply is turned on. Therefore, if the power-on timing of any other inverter is delayed, the communications cannot be established normally, which results in a communications timeout error on the management inverter. When set to constant communication, check that the startup of other inverters is completed and power on the management inverter finally.

- Do not set 08FF hex (EEPROM Write) or 0901 hex (EEPROM Write Mode Selection) in the recipient registers. Doing so causes the co-inverter communication session to stop in the EEPROM write process.
- After changing any of the H303 to H306 data, be sure to cycle the power supply to apply the changes.

## 8-9 Modbus Communication Data Lists

R/W in the list shows whether data can be read from, or written to, the coil or holding register.  
(R: Read only, R/W: Read and write enabled)

### 8-9-1 Coil Number List

Modbus coil spec. No.	Item	R/W	Description
0000 hex	FW (Forward run)	R/W	1: ON 0: OFF
0001 hex	RV (Reverse run)	R/W	1: ON 0: OFF
0002 hex	DI1 (Multifunction input 1) <sup>*1</sup>	R/W	1: ON 0: OFF
0003 hex	DI2 (Multifunction input 2) <sup>*1</sup>	R/W	1: ON 0: OFF
0004 hex	DI3 (Multifunction input 3) <sup>*1</sup>	R/W	1: ON 0: OFF
0005 hex	DI4 (Multifunction input 4) <sup>*1</sup>	R/W	1: ON 0: OFF
0006 hex	DI5 (Multifunction input 5) <sup>*1</sup>	R/W	1: ON 0: OFF
000D hex	DI6 (Multifunction input 6) <sup>*1</sup>	R/W	1: ON 0: OFF
000E hex	DI7 (Multifunction input 7) <sup>*1</sup>	R/W	1: ON 0: OFF
000F hex	RS (Reset)	R/W	1: ON 0: OFF
0010 hex	FWR (During forward rotation)	R	1: ON 0: OFF
0011 hex	RVR (During reverse rotation)	R	1: ON 0: OFF
0012 hex	EXT (During DC braking or during pre-exciting)	R	1: ON 0: OFF
0013 hex	INT (Inverter shut down)	R	1: ON 0: OFF
0014 hex	BRK (During braking)	R	1: ON 0: OFF
0015 hex	NUV (DC link circuit voltage established)	R	1: ON 0: OFF
0016 hex	TL (Torque limiting)	R	1: ON 0: OFF
0017 hex	VL (During voltage limiting)	R	1: ON 0: OFF
0018 hex	IL (During current limiting)	R	1: ON 0: OFF
0019 hex	ACC (During acceleration)	R	1: ON 0: OFF
001A hex	DEC (During deceleration)	R	1: ON 0: OFF

Modbus coil spec. No.	Item	R/W	Description
001B hex	ALM (Alarm relay)	R	1: ON 0: OFF
001C hex	RL (Communications effective)	R	1: ON 0: OFF
001F hex	BUSY (During function code data writing)	R	1: ON 0: OFF
0020 hex	FA1 (Constant speed arrival)	R	1: ON 0: OFF
0021 hex	FA2 (Over set frequency arrival)	R	1: ON 0: OFF
0022 hex	IRDY (Operation ready)	R	1: ON 0: OFF
0023 hex	SETM (2nd motor selection)	R	1: ON 0: OFF
0024 hex	IPF (During restart after instantaneous power failure)	R	1: ON 0: OFF
0025 hex	THM (Thermal warning)	R	1: ON 0: OFF
0026 hex	REF (Run command source)	R	1: ON 0: OFF
0027 hex	FAN (Fan operation signal)	R	1: ON 0: OFF
0028 hex	TRY (During retry)	R	1: ON 0: OFF
0029 hex	OHF (Fin overheat warning)	R	1: ON 0: OFF
002A hex	LIFE (Life warning)	R	1: ON 0: OFF
002B hex	OLP (During active drive)	R	1: ON 0: OFF
002C hex	OL2 (Overload warning 2)	R	1: ON 0: OFF
002D hex	LOC (Low current signal)	R	1: ON 0: OFF
002E hex	OL (Overload warning)	R	1: ON 0: OFF
0030 hex	FW (Forward run)	R	1: ON 0: OFF
0031 hex	RV (Reverse run)	R	1: ON 0: OFF
0032 hex	DI1 (Multifunction input 1)	R	1: ON 0: OFF
0033 hex	DI2 (Multifunction input 2)	R	1: ON 0: OFF
0034 hex	DI3 (Multifunction input 3)	R	1: ON 0: OFF
0035 hex	DI4 (Multifunction input 4)	R	1: ON 0: OFF
0036 hex	DI5 (Multifunction input 5)	R	1: ON 0: OFF

Modbus coil spec. No.	Item	R/W	Description
003B hex	EN (Safety)	R	1: ON 0: OFF
003D hex	DI6 (Multifunction input 6)	R	1: ON 0: OFF
003E hex	DI7 (Multifunction input 7)	R	1: ON 0: OFF
003F hex	RS (Reset)	R	1: ON 0: OFF
0040 hex	DO1 (Multifunction output terminal 1)	R	1: ON 0: OFF
0041 hex	DO2 (Multifunction output terminal 2)	R	1: ON 0: OFF
0048 hex	RO (Multifunction relay output)	R	1: ON 0: OFF

\*1. You can turn ON/OFF terminal input using Modbus communications by setting "4. RS-485 communication" in 1st RUN Command Selection (F02)/2nd RUN Command Selection (E102). For details on the relationship between terminal block input and ON status, refer to 7-2-1 *Multifunction Input Selection* on page 7-26.

## 8-9-2 Register List

The following describes the data format and register Nos. when parameters are accessed via Modbus communication.

### Data Format Specification

All data in the data field of a communications frame is represented as 16-bit binary data as shown below.

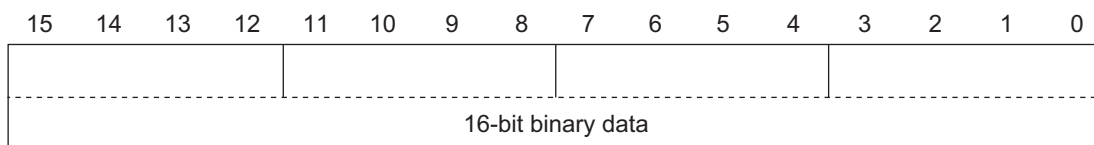

For convenience of description, 16-bit data is divided into the upper byte (8 bits from 15 to 8) and the lower byte (8 bits from 7 to 0) and represented in hexadecimal.

For example, the following data is 1234 hex in hexadecimal representation and is described as

12 <sub>Hex</sub>	34 <sub>Hex</sub>
-------------------	-------------------

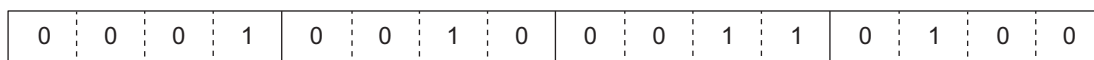

#### Data Format [1]: Integer Data (Positive), Resolution 1

Example: **1st Rated Voltage at Base Frequency (F05) = 200 V**

200 = 00C8 hex → 

00 <sub>Hex</sub>	C8 <sub>Hex</sub>
-------------------	-------------------

#### Data Format [2]: Integer Data (Positive/Negative), Resolution 1

Example: -20

-20 = FFEC hex → 

FF <sub>Hex</sub>	EC <sub>Hex</sub>
-------------------	-------------------

**Data Format [3]: Decimal Point Data (Positive), Resolution 0.1**

Example: **1st Maximum Output Frequency (F03)** = 70.0 Hz

$70.0 \times 10 = 700 = 02BC$  hex → 

02 <sub>Hex</sub>	BC <sub>Hex</sub>
-------------------	-------------------

**Data Format [4]: Decimal Point Data (Positive/Negative), Resolution 0.1**

Example: **Input Terminal [AI1] Offset (C31)** = -5.0%

$-5.0 \times 10 = -50 = FFCE$  hex → 

FF <sub>Hex</sub>	CE <sub>Hex</sub>
-------------------	-------------------

**Data Format [5]: Decimal Point Data (Positive), Resolution 0.01**

Example: **Multi-step Frequency Reference 1 (C05)** = 50.25 Hz

$50.25 \times 100 = 5,025 = 13A1$  hex → 

13 <sub>Hex</sub>	A1 <sub>Hex</sub>
-------------------	-------------------

**Data Format [6]: Decimal Point Data (Positive/Negative), Resolution 0.01**

Example: **Torque Value (M07)** = -85.38%

$-85.38 \times 100 = -8,538 = DEA6$  hex → 

DE <sub>Hex</sub>	A6 <sub>Hex</sub>
-------------------	-------------------

**Data Format [7]: Decimal Point Data (Positive), Resolution 0.001**

Example: **Electronic Thermal for Braking Resistor Allowable Average Loss (F51)** = 0.105 kW

$0.105 \times 1,000 = 105 = 0069$  hex → 

00 <sub>Hex</sub>	69 <sub>Hex</sub>
-------------------	-------------------

**Data Format [10]: Alarm Code**

Code	Description	Code	Description
0	No alarm	---	
1	Overcurrent Protection (During Acceleration)	0c1	37 Tuning Error er7
2	Overcurrent Protection (During Deceleration)	0c2	42 Step-out Detection/Magnetic Pole Position Detection Error during Startup erd
3	Overcurrent Protection (During Constant Speed)	0c3	46 Output Phase Loss Error 0pl
6	Overvoltage Protection (During Acceleration)	0u1	47 Speed Mismatch or Excessive Speed Deviation ere
7	Overvoltage Protection (During Deceleration)	0u2	50 Magnetic Pole Position Detection Error erc
8	Overvoltage Protection (During Constant Speed)	0u3	51 Data Save Error during Undervoltage erf
10	Undervoltage	lu	52 Excessive Position Deviation Error d0
11	Input Phase Loss Error	lin	53 RS-485 Communication Error erp
16	Inrush Current Prevention Circuit Error	pbf	54 Hardware Error erh
17	Cooling Fin Overheat Error	0h1	56 Positioning Control Error ero
18	External Trip	0h2	57 Enable Circuit Failure ecf
19	Inverter Overheat Error	0h3	58 Terminal [Ai2]All Current Input Wire Break Detection cof
			59 Breaking Transistor Error dba

Code	Description	Code	Description
20	Thermistor Error	0h4	65 Customizable Logic Abnormality ecl
22	Braking Resistor Overheat Error	dbh	70 Inrush Current Prevention Resistor Overheat 0h6
23	1st Motor Overload Protection	0l1	101 Motor Overload Warning 0l
24	2nd Motor Overload Protection	0l2	102 Cooling Fin Overheat Warning 0h
25	Inverter Overload Protection	0lu	103 Life Warning lif
27	Overspeed	0s	104 Analog Input Reference Command Loss Detected ref
28	Abnormal Setting Related to the PG Option Card	pg	105 PID Warning Output pid
31	EEPROM Error	er1	106 Low Torque Detected uTl
32	Operator Communications Error	er2	107 PTC thermistor activated pTc
33	CPU Error	er3	108 Motor Run Time Over rTe
34	Option Timeout	er4	109 Number of Startups Over cnT
35	Option Error	er5	253 Locked by Password lok
36	Operation Error	er6	254 Mock Alarm err

Example: Overvoltage Protection (During Acceleration) (0u1)

6 = 0006 hex → 00Hex 06Hex

#### Data Format [11]: Capacity Code (in kW)

The data is 100 times the capacity (kW) as shown in the table below.

Capacity (kW)	Data
0.1	10
0.2	20
0.4	40
0.75	75
1.5	150
2.2	220
3.7	370
5.5	550
7.5	750
11	1,100
15	1,500
18.5	1,850
22	2,200

Example: 2.2 kW

$2.20 \times 100 = 220 = 00DC$  hex → 00Hex DCHex

#### Data Format [12]: Floating Point Data (Acceleration/Deceleration Time, PID Conversion Coefficient)

15	14	13	12	11	10	9	8	7	6	5	4	3	2	1	0
		0	0	0											
Polarity		Not used			Exponent part			Mantissa part							



Polarity: 0 → Positive (+), 1 → Negative (-), Exponent part: 0 to 3, Mantissa part: 1 to 999

Value represented in this format = (Polarity) mantissa part × 10 to the power of (exponent part - 2)

Value	Mantissa part	Exponent part	10 to the power of (exponent part - 2)
0.01 to 9.99	1 to 999	0	0.01
10.0 to 99.9	100 to 999	1	0.1
100 to 999	100 to 999	2	1
1,000 to 9,990	100 to 999	3	10

Example: **1st Acceleration Time 1 (F07)** = 20.0 s

20.0 = 200 × 0.1 → 0000 0100 1100 1000<sub>b</sub> = 04C8 hex → 00Hex C8Hex

#### Data Format [14]: Operation Command

15	14	13	12	11	10	9	8	7	6	5	4	3	2	1	0
RST	DI7	DI6	0	0	0	0	0	0	DI5	DI4	DI3	DI2	DI1	REV	FWD
General-purpose input			Not used						General-purpose input						

RST: Alarm reset

FWD: Forward command

REV: Reverse command

(All bits are ON with 1 regardless of the positive/negative logic setting.)

Example: **Operation command (S06)** = FWD, DI1 = ON

0000 0000 0000 0101<sub>b</sub> = 0005 hex → 00Hex 05Hex

#### Data Format [15]: General-purpose Output Terminal

15	14	13	12	11	10	9	8	7	6	5	4	3	2	1	0	
0	0	0	0	0	0	0	0	RO	0	0	0	0	0	DO2	DO1	
Not used								General-purpose output		Not used					General-purpose output	

RO: Relay output

FWD: Forward command

REV: Reverse command

(All bits are ON with 1 regardless of the positive/negative logic setting.)

Example: **Output Terminal Monitor (M15)** DO1 = ON

0000 0000 0000 0001<sub>b</sub> = 0001 hex → 00Hex 01Hex

#### Data Format [16]: Operation Status

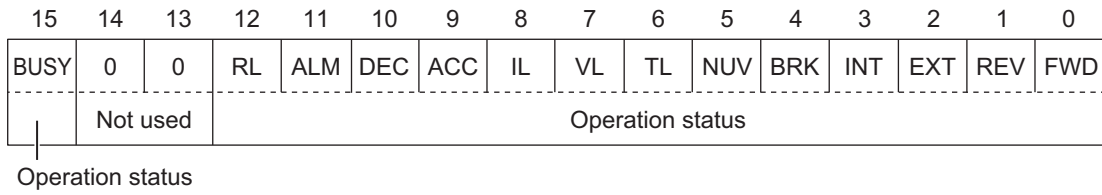

(All bits are ON or active with 1.)

Bit	Symbol	Description	Bit	Symbol	Description
0	FWD	During forward operation	8	IL	During current limiting
1	REV	During reverse operation	9	ACC	During acceleration
2	EXT	Direct DC braking (or during pre-exciting)	10	DEC	During deceleration
3	INT	Inverter shut down	11	ALM	Alarm relay
4	BRK	During braking	12	RL	Communications effective
5	NUV	Main circuit DC voltage estab- lished (Undervoltage with 0)	13	0	---
6	TL	Torque limiting	14	0	---
7	VL	During voltage limiting	15	BUSY	During parameter code data writing

Example: **Operation Status 1 Monitor (M14)** = During forward operation and during acceleration

0000 0010 0000 0001<sub>b</sub> = 0401 hex → 04<sub>Hex</sub> 01<sub>Hex</sub>

**Data Format [19]: Current Value**

A current value is decimal point data (positive), resolution 0.01.

Example: **1st Motor Electronic Thermal Level (F11)** = 3.60 A

3.60 × 100 = 360 = 0168 hex → 01<sub>Hex</sub> 68<sub>Hex</sub>

**Data Format [20]: Communications Error Code**

Code	Description
1	Non-existent parameter No. specified
2	Non-existent parameter No. specified
3	Improper data (Range error)
7	NAK (Link priority, no right, write disabled)
71	Checksum error, CRC error
72	Parity error
73	Framing error, overrun error, buffer full

Example: Improper address

2 = 0002 hex → 00<sub>Hex</sub> 02<sub>Hex</sub>

**Data Format [21]: Auto Tuning**

15	14	13	12	11	10	9	8	7	6	5	4	3	2	1	0
0	0	0	0	0	0	REV	FWD								
Not used						Rotation direction		Data part							

(Data part)

0: Disable

1: Tune the motor parameters while stopped

2: Tune the motor parameters while rotating

4: Tune the PM motor magnetic pole position offset while rotating

5: Tune the motor %R1 and %X while stopped

Example: **1st Auto Tuning Function Selection** (P04) = 2: Tune the motor parameters while rotating, forward operation

2 = 0102 hex → 01Hex 02Hex

#### Data Format [22]: Frequency Data

Decimal point data (positive), resolution 0.01 Hz

Example: **Multi-step Frequency Reference 1** (C05) = 50.25 Hz

$50.25 \times 100 = 5,025 = 13A1$  hex → 13Hex A1Hex

#### Data Format [24]: Floating Point Data

15	14	13	12	11	10	9	8	7	6	5	4	3	2	1	0
Exponent part		Mantissa part													

Exponent part: 0 to 3, Mantissa part: 1 to 9,999

Value represented in this format = Mantissa part  $\times$  10 to the power of (exponent part - 2)

Value	Mantissa part	Exponent part	10 to the power of (exponent part - 2)
0.00 to 99.99	0 to 9,999	0	0.01
100.0 to 999.9	1,000 to 9,999	1	0.1
1,000 to 9,999	1,000 to 9,999	2	1
10,000 to 99,990	1,000 to 9,999	3	10

Example: **Power Consumption Monitor** (W21) = 10.02 kW

10.02 = Mantissa part: 1,002 (3EA hex), Exponent part: 0 = 03EA hex → 03Hex EAHex

Example: **Power Consumption Monitor** (W21) = 100.2 kW

100.2 = Mantissa part: 1,002 (3EA hex), Exponent part: 1 = 43EA hex → 43Hex EAHex

Example: **Power Consumption Monitor** (W21) = 9,999 kW

100.2 = Mantissa part: 9,999 (270F hex), Exponent part: 2 = 670F hex → 67Hex 0FHex

#### Data Format [29]: Positive/Negative Data with $\pm 20,000$ as $\pm 100\%$

Example: **Frequency Reference** (S01) = -20,000 (= -100% = Maximum output frequency)

-20,000 = B1E0 hex → B1<sub>Hex</sub> E0<sub>Hex</sub>

Example: **Frequency Reference** (S01) = 20,000 (= 100% = Maximum output frequency)

20,000 = 4E20 hex → 4E<sub>Hex</sub> 20<sub>Hex</sub>

**Data Format [35]: ROM Version**

Setting range: 0 to 59,999

Example: **ROM Version** (M25) = 0064 hex

00<sub>Hex</sub> 64<sub>Hex</sub> → 0064 hex = 100

**Data Format [37]: Floating Point Data (Load Shaft Speed, etc.)**

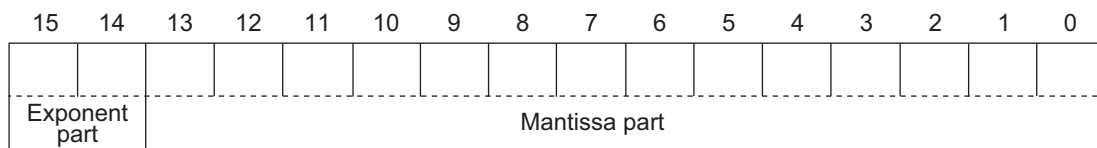

Exponent part: 0 to 3, Mantissa part: 1 to 9,999

Value represented in this format = Mantissa part × 10 to the power of (exponent part - 2)

Value	Mantissa part	Exponent part	10 to the power of (exponent part - 2)
0.01 to 99.99	1 to 9,999	0	0.01
100.0 to 999.9	1,000 to 9,999	1	0.1
1,000 to 9,999	1,000 to 9,999	2	1
10,000 to 99,990	1,000 to 9,999	3	10

Example: **Rotate Speed Monitor** (W08) = 99,990 r/min

99,990 = Mantissa part: 9,999 (270F hex), Exponent part: 3 = E70F hex → E7<sub>Hex</sub> 0F<sub>Hex</sub>

Example: **Rotate Speed Monitor** (W08) = 9,999 r/min

9,999 = Mantissa part: 9,999 (270F hex), Exponent part: 2 = A70F hex → A7<sub>Hex</sub> 0F<sub>Hex</sub>

Example: **Rotate Speed Monitor** (W08) = 9.999 r/min

999.9 = Mantissa part: 9,999 (270F hex), Exponent part: 1 = 670F hex → 67<sub>Hex</sub> 0F<sub>Hex</sub>

Example: **Rotate Speed Monitor** (W08) = 99.99 r/min

99.99 = Mantissa part: 9,999 (270F hex), Exponent part: 0 = 270F hex → 27<sub>Hex</sub> 0F<sub>Hex</sub>

**Data Format [41]: Alarm History**

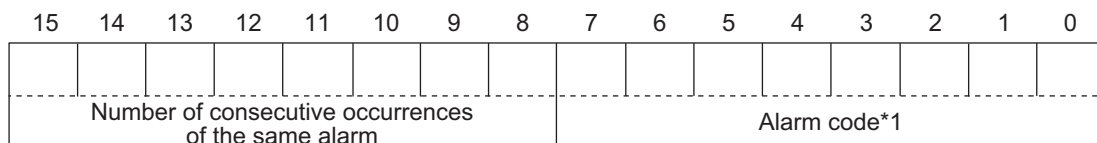

\*1: For alarm codes, refer to “Data Format [10]: Alarm Code” in this section.

This gives the contents of the alarm that occurred and the number of consecutive occurrences of the alarm.

Example: **Last Alarm History/Number of Consecutive Same Alarms** (X05) = 021B hex

02<sub>Hex</sub> 1B<sub>Hex</sub> → Number of consecutive occurrences of the same alarm: 2, Alarm code: 1B hex = 27  
OS (Overspeed)

#### Data Format [43]: Operation Command (for I/O Check)

15	14	13	12	11	10	9	8	7	6	5	4	3	2	1	0
0	0	0	EN2	EN1	0	0	0	0	DI5	DI4	DI3	DI2	DI1	DI7	DI6
Not used			EN input		Not used				General-purpose input						

(All bits are ON with 1.)

Example: **Input Terminal Monitor** (W40) = 0061 hex

00<sub>Hex</sub> 61<sub>Hex</sub> → 0000 0000 0110 0001<sub>b</sub> = DI4, DI5, and DI6 are ON

#### Data Format [44]: Operation Status 2

15	14	13	12	11	10	9	8	7	6	5	4	3	2	1	0
0	OL	LOC	OL2	OLP	LIFE	OHF	TRY	FAN	REF	THM	IPF	SETM	IRDY	FDT1	FAR1
Not used	Operation status														

(All bits are ON or active with 1.)

Bit	Symbol	Description	Bit	Symbol	Description
0	FAR1	Constant speed arrival	8	TRY	During retry
1	FDT1	Over set Frequency arrival	9	OHF	Fin Overheat warning
2	IRDY	Operation ready	10	LIFE	Life warning
3	SETM	2nd motor selection	11	OLP	During active drive
4	IPF	During restart after instantaneous power failure	12	OL2	Overload warning 2
5	THM	Thermal warning	13	LOC	Light load detection
6	REF	RUN command source	14	OL	Overload warning
7	FAN	Fan operation signal	15	0	---

Example: **Running Status 3 Monitor** (M70) = 0281 hex

02<sub>Hex</sub> 81<sub>Hex</sub> → 0000 0010 1000 0001<sub>b</sub> = FAR1, FAN, and OHF are ON

#### Data Format [45]: Floating Point Data

15	14	13	12	11	10	9	8	7	6	5	4	3	2	1	0
Exponent part			Mantissa part												

Exponent part: 0 to 3, Mantissa part: 0 to 9,999

Value represented in this format = Mantissa part × 10 to the power of (exponent part - 3)

Value	Mantissa part	Exponent part	10 to the power of (exponent part - 3)
0.000 to 9.999	0 to 9,999	0	0.001

Value	Mantissa part	Exponent part	10 to the power of (exponent part - 3)
10.00 to 99.99	1,000 to 9,999	1	0.01
100.0 to 999.9	1,000 to 9,999	2	0.1
1,000 to 9,999	1,000 to 9,999	3	1

Example: **Data Used Integrating Electric Power (W82)** = 9,999 kW

9,999 = Mantissa part: 9,999 (270F hex), Exponent part: 2 = A70F hex → A7<sub>Hex</sub> 0F<sub>Hex</sub>

Example: **Data Used Integrating Electric Power (W82)** = 999.9kW

999.9 = Mantissa part: 9,999 (270F hex), Exponent part: 1 = 670F hex → 67<sub>Hex</sub> 0F<sub>Hex</sub>

Example: **Data Used Integrating Electric Power (W82)** = 99.99kW

99.99 = Mantissa part: 9,999 (270F hex), Exponent part: 0 = 270F hex → 27<sub>Hex</sub> 0F<sub>Hex</sub>

#### Data Format [67]: RUN Command Source Monitor

Code	Description	Remarks
0	Digital Operator positive direction terminal	Same as the selection for <b>RUN Command Selection (F02/E102)</b>
1	Terminal command (FW or RV)	
2	Digital Operator forward rotation	
3	Digital Operator reverse rotation	
4 to 20	Reserved	
21	RS-485 communications	
22	Fieldbus (Reserved)	
23	Support Tool	

Example: **RUN Command Source Monitor (W28)** = 0001 hex

00<sub>Hex</sub> 01<sub>Hex</sub> → 1 = Terminal command (FW or RV)

#### Data Format [68]: Frequency Reference Source Code

Code	Description	Remarks
0	Digital Operator (Increment/Decrement key) (No output frequency takeover)	Same as the selection for <b>Frequency Reference Selection</b> (F01/C30)
1	Analog voltage input (terminal [AI1])	
2	Analog current input (terminal [AI2] (AI))	
3	Analog voltage input (terminal [AI1]) + analog current input (terminal [AI2] (AI))	
5	Analog voltage input (terminal AI2 (AIV))	
7	UP/DOWN control	
8	Digital Operator (Increment/Decrement key) (Output frequency takeover)	
10	Pattern operation	
13	Pulse train input or Frequency calculation	
21	RS-485 communications	
22	Fieldbus (Reserved)	
23	Support Tool	
24	Multi-step Frequency	
25	Jogging Frequency	
30	PID Control Operator Process	
31	PID Control Analog Process	
33	PID Control UP/DOWN control	
34	PID Control Communication Process	
36	PID Control Multi-Step Terminal Process	
255	Not Selected	

Example: **Frequency and PID Command Source Monitor** (W29) = 000A hex

00<sub>Hex</sub> 0A<sub>Hex</sub> → 10 = Pattern operation

#### Data Format [74]: Integer Data (Positive), in 10 Hours

Example: **1st Remaining Time before the Next Motor Maintenance** (M81) = 12,340 h

12340 ÷ 10 = 04D2<sub>h</sub> → 04<sub>H</sub> D2<sub>H</sub>

#### Data Format [76]: Operation Status 2

	15	14	13	12	11	10	9	8	7	6	5	4	3	2	1	0
Drive motor type																
	Not used									Not used	Selected motor		Control method			

During speed control

Signal name	Description
Control method	Indicates the final control method including set value, terminal status, etc. 0: IM V/f control 1: IM Dynamic torque vector control without speed sensor 3: IM V/f control with speed sensor 4: IM Dynamic torque vector control with speed sensor 5: IM Vector control without speed sensor 6: IM Vector control with speed sensor 15: PM Vector control without speed and pole position sensor 16: PM Vector control with speed and pole position sensor Others: Reserved
Selected motor	Indicates the selected motor number. 00 <sub>b</sub> : 1st motor 01 <sub>b</sub> : 2nd motor
During speed control	1 during control
Drive motor type	0: Induction motor 1: Synchronous motor

Example: **Running Status 2 Monitor (M74)** = 0003 hex

00<sub>Hex</sub> 03<sub>Hex</sub> → 0000 0000 0000 0011<sub>b</sub> = IM V/f control with speed sensor, 1st motor, indication motor

**Data Format [84]: Pattern Operation**

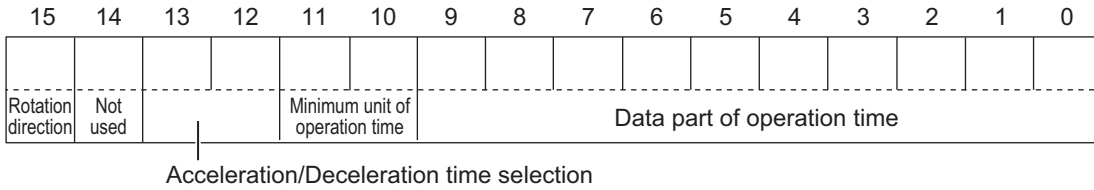

Item	Description
Rotation direction	0: Forward, 1: Reverse
Acceleration/Deceleration time selection	0: <b>1st Acceleration Time 1 (F07)/1st Deceleration Time 1 (F08)</b> 1: <b>2nd Acceleration Time 1 (E10)/2nd Deceleration Time 1 (E11)</b> 2: <b>1st Acceleration Time 2 (E12)/1st Deceleration Time 2 (E13)</b> 3: <b>2nd Acceleration Time 2 (E14)/2nd Deceleration Time 2 (E15)</b>
Minimum unit of operation time	0: 0.01 1: 0.1 2: 1 3: 10
Data part of operation time	Exponent part 0: 000 to 999 Exponent part not 0: 100 to 999

Example: **Pattern Operation Stage 1 Operation Setting (C22)** = Reverse, 2nd Acceleration/Deceleration Time, and 10.0 s

Rotation direction: Reverse (8000 hex)

Acceleration/Deceleration time: 2nd Acceleration/Deceleration Time (1000 hex)

Operation time: 10.0 s = 0.1 × 100 (0400 hex + 0064 hex)

Therefore, the set value is

8000 hex + 1000 hex + 0400 hex + 0064 hex = 9464 hex → 94<sub>Hex</sub> 64<sub>Hex</sub>

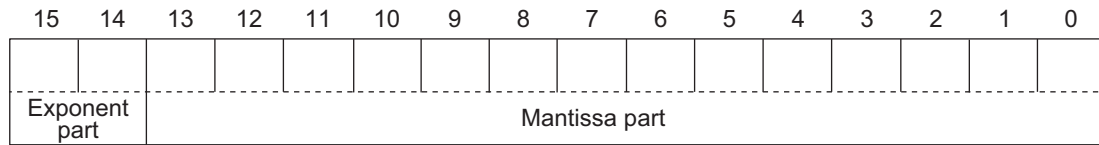

**Data Format [93]: Floating Point Data**

Exponent part: 0 to 3, Mantissa part: 0 to 9,999

Value represented in this format = Mantissa part × 10 to the power of (exponent part - 1)

Value	Mantissa part	Exponent part	10 to the power of (exponent part - 1)
0.0 to 999.9	0 to 9,999	0	0.1
1,000 to 9,999	1,000 to 9,999	1	1
10,000 to 99,990	1,000 to 9,999	2	10
100,000 to 999,900	1,000 to 9,999	3	100

Example: **Integrated Power Monitor (W81)** = 12,340

12,340 = Mantissa part: 1,234 (04D2 hex), Exponent part: 2 = C4D2 hex → C4<sub>Hex</sub> D2<sub>Hex</sub>

Example: **Integrated Power Monitor (W81)** = 567.8

567.8 = Mantissa part: 5,678 (162E hex), Exponent part: 0 = 162E hex → 16<sub>Hex</sub> 2E<sub>Hex</sub>

**Data Format of Inverter Parameters**

Parameter No.	MODBUS address (MSB)	MODBUS address (LSB)	Parameter name	Communication data format (during single-word access)	Communication data format (during double-word access)
F00	3000h	-	Operator Protection Function Selection	1	-
F01	3001h	-	1st Frequency Reference Selection	1	-
F02	1201h	-	1st RUN Command Selection	1	-
F03	3003h	-	1st Maximum Output Frequency	3	-
F04	3004h	-	1st Base Frequency	3	-
F05	3005h	-	1st Rated Voltage at Base Frequency	1	-
F06	3006h	-	1st Rated Voltage at Maximum Output Frequency	1	-
F07	1102h	1103h	1st Acceleration Time 1	12	6
F08	1104h	1105h	1st Deceleration Time 1	12	6
F09	300Bh	-	1st Manual Torque Boost Voltage	3	-
F10	300Ch	-	1st Motor Electronic Thermal Characteristic Selection	1	-
F11	300Dh	-	1st Motor Electronic Thermal Level	19	-

Parameter No.	MODBUS address (MSB)	MODBUS address (LSB)	Parameter name	Communication data format (during single-word access)	Communication data format (during double-word access)
F12	300Eh	-	1st Motor Electronic Thermal Time Constant	3	-
F14	3010h	-	Power Interruption Restart Mode Selection	1	-
F15	124Eh	124Fh	1st Frequency Upper Limit	5	5
F16	1250h	1251h	1st Frequency Lower Limit	5	5
F18	3016h	-	Input Terminal [AI1, AI2] Bias for 1st Frequency Command	6	-
F20	3018h	-	1st DC Injection Braking Start Frequency	3	-
F21	3019h	-	1st DC Injection Braking Level	1	-
F22	301Ah	-	1st DC Injection Braking Time	5	-
F23	301Bh	-	1st Starting Frequency	3	-
F24	301Ch	-	1st Starting Frequency 1 Holding Time	5	-
F25	301Dh	-	1st Stop Frequency	3	-
F26	301Eh	-	Carrier Frequency	1	-
F27	301Fh	-	Motor Sound Tone	1	-
F29	3021h	-	Output Terminal [AO] Mode Selection	1	-
F30	3022h	-	Output Terminal [AO] Gain	1	-
F31	3023h	-	Output Terminal [AO] Function Selection	1	-
F33	3025h	-	Output Terminal [AO] Pulse Rate (PO)	1	-
F37	3029h	-	1st V/f Characteristics Selection	1	-
F38	302Ah	-	1st Stop Frequency Detection Method Selection	1	-
F39	302Bh	-	1st Stop Frequency Holding Time	5	-
F40	132Ah	-	Torque Limit 1	1	-
F41	132Bh	-	Torque Limit 2	1	-
F42	302Eh	-	1st Drive Control Selection	1	-
F43	302Fh	-	1st Overload Protect Function Selection	1	-
F44	3030h	-	1st Overload Protect Level	1	-
F50	3036h	-	Electronic Thermal for Braking Resistor Discharging Capacity	1	-
F51	3037h	-	Electronic Thermal for Braking Resistor Allowable Average Loss	45	-
F52	3038h	-	Braking Resistor Resistance	12	-
F58	303Eh	-	Output Terminal [AO] Filter	5	-
F59	303Fh	-	Output Terminal [AO] Bias	4	-
F80	3054h	-	Load Mode Selection	1	-

Parameter No.	MODBUS address (MSB)	MODBUS address (LSB)	Parameter name	Communication data format (during single-word access)	Communication data format (during double-word access)
E01	30C1h	-	Input Terminal [DI1] Function Selection	1	-
E02	30C2h	-	Input Terminal [DI2] Function Selection	1	-
E03	30C3h	-	Input Terminal [DI3] Function Selection	1	-
E04	30C4h	-	Input Terminal [DI4] Function Selection	1	-
E05	30C5h	-	Input Terminal [DI5] Function Selection	1	-
E10	2102h	2103h	2nd Acceleration Time 1	12	6
E11	2104h	2105h	2nd Deceleration Time 1	12	6
E12	1273h	1274h	1st Acceleration Time 2	12	6
E13	1275h	1276h	1st Deceleration Time 2	12	6
E14	226Eh	226Fh	2nd Acceleration Time 2	12	6
E15	2270h	2271h	2nd Deceleration Time 2	12	6
E16	132Ch	-	Torque Limit 3	1	-
E17	132Dh	-	Torque Limit 4	1	-
E20	30DAh	-	Output Terminal [DO1] Function Selection	1	-
E21	30DBh	-	Output Terminal [DO2] Function Selection	1	-
E27	30E1h	-	Output Terminal [ROA, ROB] Function Selection	1	-
E29	30E3h	-	Frequency Arrival 2 ON Timer	5	-
E30	30E4h	-	Frequency Arrival Detection Width (FAR1/FAR2/FAR3/FDT3/FDT4)	3	-
E31	30E5h	30E6h	Frequency Detection Level1 (FDT1/FDT3)	3	3
E32	30E7h	30E8h	Frequency Detection Hysteresis Width (FDT1/ FDT2)	3	3
E34	30EAh	-	Overload early warning 2 Level (OL2)	19	-
E35	30EBh	-	Overload early warning 2 Detection Timer (OL2)	5	-
E36	30ECh	30EDh	Frequency Detection Level 2 (FDT2/FDT4)	3	3
E37	30EEh	-	1st Overload Early Warning Detection Level	19	-
E38	30EFh	-	1st Overload Early Warning Detection Timer / Low Current detection level (OL, LOC)	5	-

Parameter No.	MODBUS address (MSB)	MODBUS address (LSB)	Parameter name	Communication data format (during single-word access)	Communication data format (during double-word access)
E39	30F0h	-	Display Coefficient 1 for Transport Time / Auxiliary Display Coefficient 1 for Speed Monitor	45	-
E42	30F3h	-	Operator Display Filter	3	-
E43	30F4h	-	Operator Display Selection during Run	1	-
E44	30F5h	-	Operator Display when Stopped Selection	1	-
E48	30F9h	-	Operator Display Speed Monitor Item Selection	1	-
E49	30FAh	-	Torque Command Monitor Polarity Selection	1	-
E50	30FBh	-	1st Frequency Conversion Coefficient	5	-
E51	30FCh	-	Display Coefficient for Integrated Power	45	-
E52	30FDh	-	Operator Display Selection	1	-
E55	3101h	-	2nd Overload Warning Detection Level	19	-
E56	3102h	-	2nd Overload Early Warning Detection Timer	5	-
E61	3107h	-	Input Terminal [AI1] Function Selection	1	-
E62	3108h	-	Input Terminal [AI2] Function Selection (AI) (E62)	1	-
E63	3109h	-	Input Terminal [AI2] Function Selection (AIV) (E63)	1	-
E64	310Ah	-	Operator Reference Frequency Saving Selection	1	-
E65	310Bh	-	Reference Loss Detection Operation Selection	1	-
E76	3116h	-	Main Circuit DC Voltage Low-voltage Detection Level	1	-
E78	3118h	-	Overtorque/Undertorque Detection Level at Forward Power Running	1	-
E79	3119h	-	Torque detection 1 Detection Timer	5	-
E80	311Ah	-	Overtorque/Undertorque Detection Level at Reverse Regeneration	1	-
E98	312Ch	-	Input Terminal [DI6] Function Selection	1	-
E99	312Dh	-	Input Terminal [DI7] Function Selection	1	-
E102	3182h	-	2nd RUN Command Selection	1	-

Parameter No.	MODBUS address (MSB)	MODBUS address (LSB)	Parameter name	Communication data format (during single-word access)	Communication data format (during double-word access)
E103	3183h	3184h	Acceleration Stop Frequency	22	5
E104	3185h	3186h	Acceleration Stop Time	3	3
E105	3187h	3188h	Deceleration Stop Frequency	22	5
E106	3189h	318Ah	Deceleration Stop Time	3	3
E107	318Bh	-	Multi-step Frequency Selection	1	-
E109	2215h	2216h	2nd Frequency Reference/2nd Multi-step Frequency Reference 0	22	5
E111	3191h	-	Jogging Operation Selection	1	-
E112	3192h	-	1st Torque Boost Function Selection	1	-
E113	3193h	-	2nd Torque Boost Function Selection	1	-
E114	3194h	-	DC Injection Braking Selection	1	-
E115	3195h	-	External DC Injection Braking Edge/Level Selection	1	-
E117	224Eh	224Fh	2nd Frequency Upper Limit	5	5
E118	2250h	2251h	2nd Frequency Lower Limit	5	5
E119	319Bh	-	PID Control Feedback Selection	1	-
E120	319Ch	-	PID Control PID Output Variable Range for Process Control	3	-
E121	319Dh	-	PID Control PID Feedforward Selection for Process Control	1	-
E122	319Eh	-	1st AVR Function Selection	1	-
E123	319Fh	-	2nd AVR Function Selection	1	-
E124	31A0h	-	Energy-saving Operation Function Selection	1	-
E125	31A1h	-	1st 2-step Acceleration/ Deceleration switching Condition Selection	1	-
E126	31A2h	-	2nd 2-step Acceleration/ Deceleration Switching Condition Selection	1	-
E127	31A3h	31A4h	1st 2-step Acceleration Switching Frequency	22	5
E128	31A5h	31A6h	2nd 2-step Acceleration Switching Frequency	22	5
E129	31A7h	31A8h	1st 2-step Deceleration Switching Frequency	22	5
E130	31A9h	31AAh	2nd 2-step Deceleration Frequency	22	5
E131	31ABh	-	Frequency Calculation Operation Target 1	1	-

Parameter No.	MODBUS address (MSB)	MODBUS address (LSB)	Parameter name	Communication data format (during single-word access)	Communication data format (during double-word access)
E132	31ACh	-	Frequency Calculation Operation Target 2	1	-
E133	31ADh	-	Frequency Calculation Operator Selection	1	-
E134	31AEh	31AFh	Frequency Addition Amount	22	5
E135	31B0h	-	Frequency Addition Sign Selection	1	-
E139	31B5h	-	Overvoltage/Overcurrent Restart Function Selection	1	-
E146	31BCh	-	2nd Overload Protect Function Selection	1	-
E147	31BDh	-	2nd Overload Protect Level	1	-
E152	31C2h	-	Starting Frequency Selection at Frequency Pull-in Restart	1	-
E154	31C4h	31C5h	RUN Time Over (RNT)/Power ON Time Over (ONT) Detection Level	1	1
E157	31C8h	-	Analog Input [AI1] Detection Upper Limit Level	1	-
E158	31C9h	-	Analog Input [AI1] Detection Lower Limit Level	1	-
E159	31CAh	-	Analog Input [AI1] Level Detection Hysteresis Width	1	-
E160	31CBh	-	Analog Input [AI2] Detection Upper Limit Level	1	-
E161	31CCh	-	Analog Input [AI2] Detection Lower Limit Level	1	-
E162	31CDh	-	Analog Input [AI2] Level Detection Hysteresis Width	1	-
E163	31CEh	-	Analog Operation Level at [AI1] Disconnection	2	-
E164	31CFh	-	Analog Operation Level at [AI2] Disconnection	1	-
E165	31D0h	-	Carrier Frequency Automatic Reduction Function Selection	1	-
E166	31D1h	-	Non-linear V/f Frequency 1	3	-
E167	31D2h	-	Non-linear V/f Voltage 1	1	-
E168	31D3h	-	Non-linear V/f Frequency 2	3	-
E169	31D4h	-	Non-linear V/f Voltage 2	1	-
E170	31D5h	-	Non-linear V/f Frequency 3	3	-
E171	31D6h	-	Non-linear V/f Voltage 3	1	-
E172	31D7h	-	Non-linear V/f Frequency 4	3	-
E173	31D8h	-	Non-linear V/f Voltage 4	1	-
E174	31D9h	-	Non-linear V/f Frequency 5	3	-
E175	31DAh	-	Non-linear V/f Voltage 5	1	-
E176	31DBh	-	Non-linear V/f Frequency 6	3	-

Parameter No.	MODBUS address (MSB)	MODBUS address (LSB)	Parameter name	Communication data format (during single-word access)	Communication data format (during double-word access)
E177	31DCh	-	Non-linear V/f Voltage 6	1	-
E178	31DDh	-	Non-linear V/f Frequency 7	3	-
E179	31DEh	-	Non-linear V/f Voltage 7	1	-
E181	31E0h	-	Acceleration Wait Time on Brake Control	7	-
E184	31E3h	-	Low Current Detection Condition Selection (LOC)	1	-
E185	31E4h	-	Overload Warning Detection Condition Selection (OL1, OL2)	1	-
E196	31F3h	-	Overtorque/Undertorque Detection Level Reverse Power Running	1	-
E197	31F4h	-	Overtorque/Undertorque Detection Level Forward Regeneration	1	-
E198	31F5h	-	Overtorque/Undertorque Detection Condition Selection	1	-
E199	31F6h	-	0Hz Detection Output Detection Level (ZS)	5	-
C01	3241h	3242h	Jump Frequency 1	3	3
C02	3243h	3244h	Jump Frequency 2	3	3
C03	3245h	3246h	Jump Frequency 3	3	3
C04	3247h	-	Jump Frequency Skip Width	3	-
C05	1217h	1218h	Multi-step Frequency Reference 1	22	5
C06	1219h	121Ah	Multi-step Frequency Reference 2	22	5
C07	121Bh	121Ch	Multi-step Frequency Reference 3	22	5
C08	121Dh	121Eh	Multi-step Frequency Reference 4	22	5
C09	121Fh	1220h	Multi-step Frequency Reference 5	22	5
C10	1221h	1222h	Multi-step Frequency Reference 6	22	5
C11	1223h	1224h	Multi-step Frequency Reference 7	22	5
C12	1225h	1226h	Multi-step Frequency Reference 8	22	5
C13	1227h	1228h	Multi-step Frequency Reference 9	22	5
C14	1229h	122Ah	Multi-step Frequency Reference 10	22	5
C15	122Bh	122Ch	Multi-step Frequency Reference 11	22	5

Parameter No.	MODBUS address (MSB)	MODBUS address (LSB)	Parameter name	Communication data format (during single-word access)	Communication data format (during double-word access)
C16	122Dh	122Eh	Multi-step Frequency Reference 12	22	5
C17	122Fh	1230h	Multi-step Frequency Reference 13	22	5
C18	1231h	1232h	Multi-step Frequency Reference 14	22	5
C19	1233h	1234h	Multi-step Frequency Reference 15	22	5
C20	1237h	1238h	Jogging Frequency	22	5
C21	3268h	-	Pattern Operation / Timed Operation Mode Selection	1	-
C22	3269h	-	Pattern Operation Stage 1 Operation Setting	84	-
C23	326Ah	-	Pattern Operation Stage 2 Operation Setting	84	-
C24	326Bh	-	Pattern Operation Stage 3 Operation Setting	84	-
C25	326Ch	-	Pattern Operation Stage 4 Operation Setting	84	-
C26	326Dh	-	Pattern Operation Stage 5 Operation Setting	84	-
C27	326Eh	-	Pattern Operation Stage 6 Operation Setting	84	-
C28	326Fh	-	Pattern Operation Stage 7 Operation Setting	84	-
C30	3271h	-	2nd Frequency Reference Selection	1	-
C31	3272h	-	Input Terminal [AI1] Offset	4	-
C32	3273h	-	Input Terminal [AI1] Gain (Command)	5	-
C33	3274h	-	Input Terminal [AI1] Filter	5	-
C34	3275h	-	Input Terminal [AI1] Gain (Analog Input)	5	-
C35	3276h	-	Input Terminal [AI1] Polarity Selection	1	-
C36	3277h	-	Input Terminal [AI2] Offset (All)	4	-
C37	3278h	-	Input Terminal [AI2] Gain (All Command)	5	-
C38	3279h	-	Input Terminal [AI2] Filter (All)	5	-
C39	327Ah	-	Input Terminal [AI2] Gain (All Analog Input)	5	-
C40	327Bh	-	Input Terminal [AI2] Operation Selection (All)	1	-
C41	327Ch	-	Input Terminal [AI2] Offset (AIV)	4	-



Parameter No.	MODBUS address (MSB)	MODBUS address (LSB)	Parameter name	Communication data format (during single-word access)	Communication data format (during double-word access)
C42	327Dh	-	Input Terminal [AI2] Gain (AIV Command)	5	-
C43	327Eh	-	Input Terminal [AI2] Filter (AIV)	5	-
C44	327Fh	-	Input Terminal [AI2] Gain (AIV Analog Input)	5	-
C45	3280h	-	Input Terminal [AI2] Polarity Selection (AIV)	1	-
C50	3285h	-	Input Terminal [AI1, AI2] Bias Analog Input for 1st Frequency Command	5	-
C53	3288h	-	Input Terminal [AI1, AI2] Normal/Inverse Operation for 1st Frequency Command	1	-
C54	3289h	-	Input Terminal [AI1, AI2] Normal/Inverse Operation for 2nd Frequency Command	1	-
C55	328Ah	-	Input Terminal [AI1] Bias (Command)	6	-
C56	328Bh	-	Input Terminal [AI1] Bias (Analog Input)	5	-
C58	328Dh	-	Reserved	1	-
C59	328Eh	-	Input Terminal [AI1] Analog Input Adjustment Maximum Scale	12	-
C60	328Fh	-	Input Terminal [AI1] Analog Input Adjustment Minimum Scale	12	-
C61	3290h	-	Input Terminal [AI2] Bias (All Command)	6	-
C62	3291h	-	Input Terminal [AI2] Bias (All Analog Input)	5	-
C64	3293h	-	Reserved	1	-
C65	3294h	-	Input Terminal [AI2] Analog Input Adjustment Maximum Scale (All)	12	-
C66	3295h	-	Input Terminal [AI2] Analog Input Adjustment Minimum Scale (All)	12	-
C67	3296h	-	Input Terminal [AI2] Bias (AIV Command)	6	-
C68	3297h	-	Input Terminal [AI2] Bias (AIV Analog Input)	5	-
C70	3299h	-	Reserved	1	-
C71	329Ah	-	Input Terminal [AI2] Analog Input Adjustment Maximum Scale (AIV)	12	-

Parameter No.	MODBUS address (MSB)	MODBUS address (LSB)	Parameter name	Communication data format (during single-word access)	Communication data format (during double-word access)
C72	329Bh	-	Input Terminal [AI2] Analog Input Adjustment Minimum Scale (AIV)	12	-
C89	32ACh	-	Set-point Factor Numerator via Communication	2	-
C90	32ADh	-	Set-point Factor Denominator via Communication	2	-
C99	1215h	1216h	1st Frequency Reference/1st Multi-step Frequency Reference 0	22	5
P01	3301h	-	1st Motor Pole Number	1	-
P02	3302h	-	1st Motor Capacity	11	-
P03	3303h	-	1st Motor Rated Current	19	-
P04	3304h	-	1st Auto Tuning Function Selection	21	-
P05	3305h	-	1st Online Tuning Function Selection	1	-
P06	3306h	-	1st Motor Armature Resistance	19	-
P07	3307h	-	1st Motor Parameter %R1	5	-
P08	3308h	-	1st Motor Parameter %X	5	-
P09	3309h	-	1st Slip Compensation Gain for Driving	3	-
P10	330Ah	-	1st Slip Compensation Response Time	5	-
P11	330Bh	-	1st Slip Compensation Gain for Braking	3	-
P12	330Ch	-	1st Rated Slip Frequency	5	-
P13	330Dh	-	1st Iron Loss Factor 1	5	-
P16	3310h	-	1st Magnetic Saturation Factor 1	3	-
P17	3311h	-	1st Magnetic Saturation Factor 2	3	-
P18	3312h	-	1st Magnetic Saturation Factor 3	3	-
P19	3313h	-	1st Magnetic Saturation Factor 4	3	-
P20	3314h	-	1st Magnetic Saturation Factor 5	3	-
P30	331Eh	-	1st PM Motor Starting Method	1	-
P40	3328h	-	Reserved	1	-
P41	3329h	-	Reserved	4	-
P53	3335h	-	1st Motor %X Correction Factor	1	-
P55	3337h	-	1st Motor Torque Current under Vector Control	19	-

Parameter No.	MODBUS address (MSB)	MODBUS address (LSB)	Parameter name	Communication data format (during single-word access)	Communication data format (during double-word access)
P56	3338h	-	1st Induced Voltage Factor under Vector Control	1	-
P57	3339h	-	Reserved	7	-
P60	333Ch	-	1st PM Motor Armature Resistance	45	-
P61	333Dh	-	1st PM Motor d-axis Inductance	24	-
P62	333Eh	-	1st PM Motor q-axis Inductance	24	-
P63	333Fh	-	1st PM Motor Induced Voltage Ke	1	-
P64	3340h	-	1st PM Motor Iron Loss	3	-
P65	3341h	-	1st PM Motor d-axis Inductance Magnetic Saturation Correction	3	-
P74	334Ah	-	1st PM Motor Reference Current at Starting	1	-
P83	3353h	-	Reserved	3	-
P84	3354h	-	Reserved	3	-
P85	3355h	-	1st PM Motor Flux Limitation Value	3	-
P86	3356h	-	Reserved	3	-
P87	3357h	-	1st PM Motor Reference Current for Magnetic Pole Detection	1	-
P88	3358h	-	Reserved	1	-
P89	3359h	-	Reserved	1	-
P90	335Ah	-	1st PM Motor Overcurrent Protection Level	19	-
P95	335Fh	-	1st PM Motor Magnetic Pole position Offset	3	-
H03	33C3h	-	Data Initialization	1	-
H04	33C4h	-	Retry Count at Trip	1	-
H05	33C5h	-	Retry Standby Time at Trip	3	-
H06	33C6h	-	Cooling Fan Function Selection	1	-
H07	33C7h	-	Acceleration/Deceleration Pattern Selection	1	-
H08	33C8h	-	Reverse Rotation Prevention Function	1	-
H09	33C9h	-	Motor Starting Mode Auto Search Function Selection	1	-
H11	33CBh	-	Stop Selection	1	-
H12	33CCh	-	Instantaneous Overcurrent Limiting Function Selection	1	-

Parameter No.	MODBUS address (MSB)	MODBUS address (LSB)	Parameter name	Communication data format (during single-word access)	Communication data format (during double-word access)
H13	33CDh	-	Power Interruption Restart Wait Time	3	-
H14	33CEh	-	Deceleration Setting During Current Limit for Restart Mode after Power Interruption	5	-
H15	33CFh	-	Continuous Running Voltage Level	1	-
H16	33D0h	-	Allowable Time for Power Interruption Restart	3	-
H18	33D2h	-	Torque Control Operate Selection	1	-
H26	33DAh	-	Thermistor Function Selection (MOH)	1	-
H27	33DBh	-	1st Thermistor Error Detection Level (MOH)	5	-
H28	33DCh	-	Droop Control	4	-
H42	33EAh	-	Main Circuit Capacitor Service Life Coefficient (Measurement Value)	1	-
H43	33EBh	-	Cumulative Run Time of Cooling Fan	74	-
H44	33ECh	-	1st Startup Count for Motor	1	-
H45	33EDh	-	Mock Alarm	1	-
H46	33EEh	-	Auto Search Delay Time 2 for Starting Mode	3	-
H47	33EFh	-	Main Circuit Capacitor Service Life Coefficient (Initial Value)	1	-
H48	33F0h	-	Cumulative Run Time of Electrolytic capacitor	74	-
H49	33F1h	-	Auto Search Delay Time 1 for Starting Characteristic	3	-
H54	33F6h	33F7h	Jogging Acceleration Time	12	6
H55	33F8h	33F9h	Jogging Deceleration Time	12	6
H56	33FAh	33FBh	Deceleration Time for Forced Stop	12	6
H57	33FCh	-	S-curve Acceleration Range Frequency at Starting	1	-
H58	33FDh	-	S-curve Acceleration Range Frequency at End	1	-
H59	33FEh	-	S-curve Deceleration Range Frequency at Starting	1	-
H60	33FFh	-	S-curve Deceleration Range Frequency at End	1	-
H61	3400h	-	UP/DOWN Control Initial Value Selection	1	-
H63	3402h	-	Frequency Lower Limit Operation Selection	1	-

Parameter No.	MODBUS address (MSB)	MODBUS address (LSB)	Parameter name	Communication data format (during single-word access)	Communication data format (during double-word access)
H64	3403h	-	Low Frequency during Protecting Overload	3	-
H67	3406h	-	Auto Energy Saving Operation Condition Selection	1	-
H68	3407h	-	1st Slip Compensation Operating Conditions Selection	1	-
H69	3408h	-	Anti-regenerative Control Function Selection	1	-
H70	3409h	-	Overload Prevention Control	5	-
H71	340Ah	-	Over-Excitation Control Selection during Deceleration Function Selection	1	-
H72	340Bh	-	Reserved	1	-
H74	340Dh	-	Torque Limit Function Selection	1	-
H75	340Eh	-	Torque Limit Operation Selection	1	-
H76	340Fh	-	Frequency Rising Limit for Torque Limit	3	-
H77	3410h	-	Service Life of Main Circuit Capacitor Remaining Time	74	-
H78	3411h	3412h	1st Motor Maintenance Interval	74	74
H79	3413h	-	1st Preset Startup Count for Motor Maintenance	1	-
H80	3414h	-	1st Output Current Fluctuation Damping Gain	5	-
H81	3415h	-	Light Alarm Selection 1	1	-
H82	3416h	-	Light Alarm Selection 2	1	-
H84	3418h	-	Pre-excitation Level	1	-
H85	3419h	-	Pre-excitation Timer	5	-
H86	341Ah	-	Reserved	1	-
H89	341Dh	-	Motor Electronic Thermal Overload Protection Data Retention	1	-
H90	341Eh	-	Reserved	1	-
H91	341Fh	-	Current Input Wire Break Detection	3	-
H92	3420h	-	Continuous Running at the Momentary Power Failure P Proportional Gain	7	-
H93	3421h	-	Continuous Running at the Momentary Power Failure Integral Time	7	-
H94	3422h	3423h	1st Cumulative Motor Run Time	74	74

Parameter No.	MODBUS address (MSB)	MODBUS address (LSB)	Parameter name	Communication data format (during single-word access)	Communication data format (during double-word access)
H95	3424h	-	DC Injection Braking Start Characteristic Selection	1	-
H96	3425h	-	STOP Key Priority/Start Check Function	1	-
H98	3427h	-	Protection/Maintenance Function Mode Selection	1	-
H99	3428h	-	Password 2 Setting/Verification	1	-
H114	348Eh	-	Anti-regenerative Control Level	3	-
H116	3490h	-	Reserved	1	-
H117	3491h	-	Reserved	3	-
H118	3492h	-	Reserved	3	-
H119	3493h	-	Reserved	1	-
H120	3494h	-	Reserved	1	-
H121	3495h	-	Reserved	3	-
H130	349Eh	-	Reserved	7	-
H131	349Fh	-	Reserved	7	-
H133	34A1h	-	Reserved	7	-
H134	34A2h	-	Reserved	7	-
H147	34AFh	-	Speed Control Jogging Feed Forward Gain	5	-
H154	34B6h	-	Torque Bias Function Selection	1	-
H155	34B7h	-	Torque Bias Level 1	2	-
H156	34B8h	-	Torque Bias Level 2	2	-
H157	34B9h	-	Torque Bias Level 3	2	-
H158	34BAh	-	Torque Bias Mechanical Loss Compensation	1	-
H159	34BBh	-	Torque Bias Startup Timer	5	-
H161	34BDh	-	Torque Bias Shutdown Timer	5	-
H162	34BEh	-	Torque Bias Limit	1	-
H173	34C9h	-	Magnetic Flux Level at Light Load	1	-
H180	34D0h	-	Brake Error Detection Time	5	-
H185	34D5h	-	Reserved	1	-
H193	34DDh	-	User Preference Dataset Registration	1	-
H194	34DEh	-	User Preference Dataset Protection Function Selection	1	-
H195	34DFh	-	DC Injection Braking Startup Time	5	-
H196	34E0h	-	Reserved	7	-
H197	34E1h	-	User password 1 Mode selection	1	-

Parameter No.	MODBUS address (MSB)	MODBUS address (LSB)	Parameter name	Communication data format (during single-word access)	Communication data format (during double-word access)
H198	34E2h	-	User Password 1 Setting/Verification	1	-
H199	34E3h	-	User Password 1 Setting	1	-
H303	3604h	-	Co-Inverter Communication Function Selection	1	-
H304	3605h	-	Co-inverter Communication Starting Station Number (Administrator)	1	-
H305	3606h	-	Co-inverter Communication Ending Station Number (Administrator)	1	-
H306	3607h	-	Co-inverter Communication Start Selection (Administrator)	1	-
H309	360Ah	-	Output Terminal [DO1] ON Delay Time	3	-
H310	360Bh	-	Output Terminal[DO1] OFF Delay Time	3	-
H311	360Ch	-	Output Terminal [DO2] ON Delay Time	3	-
H312	360Dh	-	Output Terminal[DO2] OFF Delay Time	3	-
H313	360Eh	-	Output Terminal [ROA, ROB] ON Delay Time	3	-
H314	360Fh	-	Output Terminal [ROA, ROB] OFF Delay Time	3	-
H315	3610h	-	Logical Expression 1 Operation Target 1	1	-
H316	3611h	-	Logical Expression 1 Operation Target 2	1	-
H317	3612h	-	Logical Expression 1 Logical Operator	1	-
H318	3613h	-	Logical Expression 2 Operation Target 1	1	-
H319	3614h	-	Logical Expression 2 Operation Target 2	1	-
H320	3615h	-	Logical Expression 2 Logical Operator	1	-
H321	3616h	-	Logical Expression 3 Operation Target 1	1	-
H322	3617h	-	Logical Expression 3 Operation Target 2	1	-
H323	3618h	-	Logical Expression 3 Logical Operator	1	-
H324	3619h	-	Input Terminal [DI1] Response Time	1	-
H325	361Ah	-	Input Terminal [DI2] Response Time	1	-

Parameter No.	MODBUS address (MSB)	MODBUS address (LSB)	Parameter name	Communication data format (during single-word access)	Communication data format (during double-word access)
H326	361Bh	-	Input Terminal [DI3] Response Time	1	-
H327	361Ch	-	Input Terminal [DI4] Response Time	1	-
H328	361Dh	-	Input Terminal [DI5] Response Time	1	-
H329	361Eh	-	Input Terminal [DI6] Response Time	1	-
H330	361Fh	-	Input Terminal [DI7] Response Time	1	-
H332	3621h	-	Torque Reference Selection	1	-
H333	3622h	-	Torque Reference	1	-
H334	3623h	-	Torque Bias Polarity Selection	1	-
H339	3628h	-	Number of Sent Data of All Stations in Co-inverter Communication	1	-
H340	3629h	-	Recipient Station Number of All Stations in Co-inverter Communication 1	1	-
H341	362Ah	-	Recipient Register of All Stations in Co-inverter Communication 1	1	-
H342	362Bh	-	Sender Register of All Stations in Co-inverter Communication 1	1	-
H343	362Ch	-	Recipient Station Number of All Stations in Co-inverter Communication 2	1	-
H344	362Dh	-	Recipient Register of All Stations in Co-inverter Communication 2	1	-
H345	362Eh	-	Sender Register of All Stations in Co-inverter Communication 2	1	-
H346	362Fh	-	Recipient Station Number of All Stations in Co-inverter Communication 3	1	-
H347	3630h	-	Recipient Register of All Stations in Co-inverter Communication 3	1	-
H348	3631h	-	Sender Register of All Stations in Co-inverter Communication 3	1	-
H349	3632h	-	Recipient Station Number of All Stations in Co-inverter Communication 4	1	-



Parameter No.	MODBUS address (MSB)	MODBUS address (LSB)	Parameter name	Communication data format (during single-word access)	Communication data format (during double-word access)
H350	3633h	-	Recipient Register of All Stations in Co-inverter Communication 4	1	-
H351	3634h	-	Sender Register of All Stations in Co-inverter Communication 4	1	-
H352	3635h	-	Recipient Station Number of All Stations in Co-inverter Communication 5	1	-
H353	3636h	-	Recipient Register of All Stations in Co-inverter Communication 5	1	-
H354	3637h	-	Sender Register of All Stations in Co-inverter Communication 5	1	-
H355	3638h	-	Modbus Mapping Function Selection	1	-
H356	3639h	-	Modbus Mapping 1 External Register	1	-
H357	363Ah	-	Modbus Mapping 2 External Register	1	-
H358	363Bh	-	Modbus Mapping 3 External Register	1	-
H359	363Ch	-	Modbus Mapping 4 External Register	1	-
H360	363Dh	-	Modbus Mapping 5 External Register	1	-
H361	363Eh	-	Modbus Mapping 6 External Register	1	-
H362	363Fh	-	Modbus Mapping 7 External Register	1	-
H363	3640h	-	Modbus Mapping 8 External Register	1	-
H364	3641h	-	Modbus Mapping 9 External Register	1	-
H365	3642h	-	Modbus Mapping 10 External Register	1	-
H366	3643h	-	Modbus Mapping 1 External Register Sign	1	-
H367	3644h	-	Modbus Mapping 2 External Register Sign	1	-
H368	3645h	-	Modbus Mapping 3 External Register Sign	1	-
H369	3646h	-	Modbus Mapping 4 External Register Sign	1	-
H370	3647h	-	Modbus Mapping 5 External Register Sign	1	-

Parameter No.	MODBUS address (MSB)	MODBUS address (LSB)	Parameter name	Communication data format (during single-word access)	Communication data format (during double-word access)
H371	3648h	-	Modbus Mapping 6 External Register Sign	1	-
H372	3649h	-	Modbus Mapping 7 External Register Sign	1	-
H373	364Ah	-	Modbus Mapping 8 External Register Sign	1	-
H374	364Bh	-	Modbus Mapping 9 External Register Sign	1	-
H375	364Ch	-	Modbus Mapping 10 External Register Sign	1	-
H376	364Dh	-	Modbus Mapping 1 Scaling	7	-
H377	364Eh	-	Modbus Mapping 2 Scaling	7	-
H378	364Fh	-	Modbus Mapping 3 Scaling	7	-
H379	3650h	-	Modbus Mapping 4 Scaling	7	-
H380	3651h	-	Modbus Mapping 5 Scaling	7	-
H381	3652h	-	Modbus Mapping 6 Scaling	7	-
H382	3653h	-	Modbus Mapping 7 Scaling	7	-
H383	3654h	-	Modbus Mapping 8 Scaling	7	-
H384	3655h	-	Modbus Mapping 9 Scaling	7	-
H385	3656h	-	Modbus Mapping 10 Scaling	7	-
H386	3657h	-	Modbus Mapping 1 Internal Register	1	-
H387	3658h	-	Modbus Mapping 2 Internal Register	1	-
H388	3659h	-	Modbus Mapping 3 Internal Register	1	-
H389	365Ah	-	Modbus Mapping 4 Internal Register	1	-
H390	365Bh	-	Modbus Mapping 5 Internal Register	1	-
H391	365Ch	-	Modbus Mapping 6 Internal Register	1	-
H392	365Dh	-	Modbus Mapping 7 Internal Register	1	-
H393	365Eh	-	Modbus Mapping 8 Internal Register	1	-
H394	365Fh	-	Modbus Mapping 9 Internal Register	1	-
H395	3660h	-	Modbus Mapping 10 Internal Register	1	-
H396	3661h	-	Modbus Mapping Endian Selection	1	-
H411	36CFh	-	Input Phase Loss Protection Function Selection	1	-
H412	36D0h	-	Output Phase Loss Protection Function Selection	1	-

Parameter No.	MODBUS address (MSB)	MODBUS address (LSB)	Parameter name	Communication data format (during single-word access)	Communication data format (during double-word access)
H435	36EDh	-	Touch Probe 1 Source	1	-
H436	36EEh	-	Touch Probe 2 Source	1	-
H437	36EFh	-	Touch Probe Function	1	-
H438	36F0h	-	Feedback Value Comparison Signal Off Level	3	-
H439	36F1h	-	Feedback Value Comparison Signal On Level	3	-
H440	36F2h	-	Free Run Stop Restart Allowable Time	3	-
H441	36F3h	-	Free Run Stop Restart Operation Selection	1	-
H442	36F4h	-	Slip compensation Function Selection	1	-
H481	371Bh	-	7SEG Monitor Item Selection	1	-
H482	371Ch	-	Reserved	1	-
H483	371Dh	-	FSOE Address	1	-
H484	371Eh	-	Reserved	1	-
H485	371Fh	-	Reserved	1	-
H486	3720h	-	Reserved	1	-
H487	3721h	-	Reserved	1	-
H488	3722h	-	Reserved	1	-
H489	3723h	-	Reserved	1	-
H490	3724h	-	Reserved	3	-
A01	3841h	-	2nd Maximum Output Frequency	3	-
A02	3842h	-	2nd Base Frequency	3	-
A03	3843h	-	2nd Rated Voltage at Base Frequency	1	-
A04	3844h	-	2nd Rated Voltage at Maximum Output Frequency	1	-
A05	3845h	-	2nd Manual Torque Boost Voltage	3	-
A06	3846h	-	2nd Motor Electronic Thermal Characteristic selection	1	-
A07	3847h	-	2nd Motor Electronic Thermal Level	19	-
A08	3848h	-	2nd Motor Electronic Thermal Time Constant	3	-
A09	3849h	-	2nd DC Injection Braking Start Frequency	3	-
A10	384Ah	-	2nd DC Injection Braking Level	1	-
A11	384Bh	-	2nd DC Injection Braking Time	5	-
A12	384Ch	-	2nd Starting Frequency	3	-

Parameter No.	MODBUS address (MSB)	MODBUS address (LSB)	Parameter name	Communication data format (during single-word access)	Communication data format (during double-word access)
A13	384Dh	-	2nd V/f Characteristics Selection	1	-
A14	384Eh	-	2nd Drive Control Selection	1	-
A15	384Fh	-	2nd Motor Pole Number	1	-
A16	3850h	-	2nd Motor Capacity	11	-
A17	3851h	-	2nd Motor Rated Current	19	-
A18	3852h	-	2nd Auto-tuning Selection Function Selection	21	-
A19	3853h	-	2nd Online tuning Function Selection	1	-
A20	3854h	-	2nd Motor Armature Resistance	19	-
A21	3855h	-	2nd Motor Motor Constant %R1	5	-
A22	3856h	-	2nd Motor Motor Constant %X	5	-
A23	3857h	-	2nd Slip Compensation Gain for Driving	3	-
A24	3858h	-	2nd Slip Compensation Response Time	5	-
A25	3859h	-	2nd Slip Compensation Gain for Braking	3	-
A26	385Ah	-	2nd Rated Slip Frequency	5	-
A27	385Bh	-	2nd Iron Loss Factor 1	5	-
A30	385Eh	-	2nd Magnetic Saturation Factor 1	3	-
A31	385Fh	-	2nd Magnetic Saturation Factor 2	3	-
A32	3860h	-	2nd Magnetic Saturation Factor 3	3	-
A33	3861h	-	2nd Magnetic Saturation Factor 4	3	-
A34	3862h	-	2nd Magnetic Saturation Factor 5	3	-
A40	3868h	-	2nd Slip Compensation Operating Conditions Selection	1	-
A41	3869h	-	2nd Output Current Fluctuation Damping Gain	5	-
A43	386Bh	-	Speed Control 2 Speed Command Filter	7	-
A44	386Ch	-	Speed Control 2 Speed Detection Filter	7	-
A45	386Dh	-	Speed Control 2 P Proportional Gain	3	-
A46	386Eh	-	Speed Control 2 I Integral Time	7	-
A47	386Fh	-	Speed Control 2 FF Gain	5	-

Parameter No.	MODBUS address (MSB)	MODBUS address (LSB)	Parameter name	Communication data format (during single-word access)	Communication data format (during double-word access)
A48	3870h	-	Speed Control 2 Output Filter	7	-
A49	3871h	-	Speed Control 2 Notch Filter Resonance Frequency	1	-
A50	3872h	-	Speed Control 2 Notch Filter Attenuation Level	1	-
A51	3873h	-	2nd Cumulative Motor Run Time	74	-
A52	3874h	-	2nd Startup Counter for Motor	1	-
A53	3875h	-	2nd Motor 2 %X Correction Factor 1	1	-
A55	3877h	-	Torque Current for 2nd Vector Control	19	-
A56	3878h	-	Induced Voltage Factor for 2nd Vector Control	1	-
A57	3879h	-	Reserved	7	-
A60	387Ch	-	2nd Speed Conversion Coefficient	5	-
A61	387Dh	-	2nd Display Coefficient for Transport time / Auxiliary Display Coefficient for Speed Monitor	45	-
A62	387Eh	-	2nd Starting Frequency Holding Time	5	-
A63	387Fh	-	2nd Stop Frequency	3	-
A64	3880h	-	2nd Stop Frequency Detection Method Selection	1	-
A65	3881h	-	2nd Stop Frequency Holding Time	5	-
b43	392Bh	-	Speed Control 3 Speed Command Filter	7	-
b44	392Ch	-	Speed Control 3 Speed Detection Filter	7	-
b45	392Dh	-	Speed Control 3 P Proportional Gain	3	-
b46	392Eh	-	Speed Control 3 I Integral Time	7	-
b47	392Fh	-	Speed Control 3 FF Gain	5	-
b48	3930h	-	Speed Control 3 Output Filter	7	-
b49	3931h	-	Speed Control 3 Notch Filter Resonance Frequency	1	-
b50	3932h	-	Speed Control 3 Notch Filter Attenuation Level	1	-
r43	39EBh	-	Speed Control 4 Speed Command Filter	7	-
r44	39ECh	-	Speed Control 4 Speed Detection Filter	7	-

Parameter No.	MODBUS address (MSB)	MODBUS address (LSB)	Parameter name	Communication data format (during single-word access)	Communication data format (during double-word access)
r45	39EDh	-	Speed Control 4 P Proportional Gain	3	-
r46	39EEh	-	Speed Control 4 I Integral Time	7	-
r47	39EFh	-	Speed Control 4 FF Gain	5	-
r48	39F0h	-	Speed Control 4 Output Filter	7	-
r49	39F1h	-	Speed Control 4 Notch Filter Resonance Frequency	1	-
r50	39F2h	-	Speed Control 4 Notch Filter Attenuation Level	1	-
J01	3A81h	-	PID Control Function Selection	1	-
J02	3A82h	-	PID Control PID Command Selection	1	-
J03	3A83h	-	PID Control P Proportional Gain	7	-
J04	3A84h	-	PID Control I Integral Time	3	-
J05	3A85h	-	PID Control D Differential Time	5	-
J06	3A86h	-	PID Control Feedback Filter	3	-
J10	3A8Ah	-	PID Control Anti-reset Windup Width	1	-
J11	3A8Bh	-	PID Control Select Warning Output Selection	1	-
J12	3A8Ch	-	PID Control Upper Limit of Warning (AH)	2	-
J13	3A8Dh	-	PID Control Lower Limit of Warning (AL)	2	-
J15	3A8Fh	-	PID Control Sleep Frequency for Process Control	3	-
J16	3A90h	-	PID Control Sleep Timer for Process Control	1	-
J17	3A91h	-	PID Control Restart Frequency after Stopping for Process Control	3	-
J18	3A92h	-	PID Control PID Output Upper Limit	2	-
J19	3A93h	-	PID Control PID Output Lower Limit	2	-
J23	3A97h	-	PID Control Restart Feedback Deviation after Stopping for Process Control	3	-
J24	3A98h	-	PID Control Restart Delay Time after Stopping for Process Control	1	-
J57	3AB9h	-	PID Control Operator PID Reference Position for Dancer	2	-

Parameter No.	MODBUS address (MSB)	MODBUS address (LSB)	Parameter name	Communication data format (during single-word access)	Communication data format (during double-word access)
J58	3ABAh	-	PID Control PID Reference Position Detection Width for Dancer	1	-
J59	3ABBh	-	PID Control P Gain 2	7	-
J60	3ABCh	-	PID Control I Integral Time 2	3	-
J61	3ABDh	-	PID Control D Differential Time 2	5	-
J62	3ABEh	-	PID Control Block Selection	1	-
J63	3ABFh	-	Overload Stop Item Selection	1	-
J64	3AC0h	-	Overload Stop Detection Level	1	-
J65	3AC1h	-	Overload Stop Mode Selection	1	-
J66	3AC2h	-	Overload Stop Operation Mode	1	-
J67	3AC3h	-	Overload Stop Detection Timer	5	-
J68	3AC4h	-	Brake Control Brake-release Current	5	-
J69	3AC5h	-	Brake Control Brake-release Frequency	3	-
J70	3AC6h	-	Brake Control Brake-release Timer	7	-
J71	3AC7h	-	Brake Control Brake-applied Frequency	3	-
J72	3AC8h	-	Brake Control Brake-applied Timer	7	-
J90	3ADAh	-	Overload Stop Function P gain	7	-
J91	3ADBh	-	Overload Stop Function Integral time	7	-
J92	3ADCh	-	Overload Stop Function Current level	3	-
J95	3ADFh	-	Brake control Brake-release Torque	5	-
J96	3AE0h	-	Brake Control Operation Selection	1	-
J97	3AE1h	-	Servo Lock Gain	7	-
J98	3AE2h	-	Servo Lock Completion Timer	7	-
J99	3AE3h	-	Servo Lock Completion Range	1	-
J105	3B45h	-	Reserved	1	-
J106	3B46h	-	PID Control Maximum Scale	12	-
J107	3B47h	-	PID Control Minimum Scale	12	-
J136	3B64h	-	PID Control Multistep PID Command 1	12	-

Parameter No.	MODBUS address (MSB)	MODBUS address (LSB)	Parameter name	Communication data format (during single-word access)	Communication data format (during double-word access)
J137	3B65h	-	PID Control Multistep PID Command 2	12	-
J138	3B66h	-	PID Control Multistep PID Command 3	12	-
d01	3FC1h	-	Speed Control 1 Speed Command Filter	7	-
d02	3FC2h	-	Speed Control 1 Speed Detection Filter	7	-
d03	3FC3h	-	Speed Control 1 P Proportional Gain	3	-
d04	3FC4h	-	Speed Control 1 I Integral Time	7	-
d05	3FC5h	-	Speed Control 1 FF Gain	5	-
d06	3FC6h	-	Speed Control 1 Output Filter	7	-
d07	3FC7h	-	Speed Control 1 Notch Filter Resonance Frequency	1	-
d08	3FC8h	-	Speed Control 1 Notch Filter Attenuation Level	1	-
d09	3FC9h	-	Speed Control Jogging Speed Command Filter	7	-
d10	3FCAh	-	Speed Control Jogging Speed Detection Filter	7	-
d11	3FCBh	-	Speed Control Jogging P Proportional Gain	3	-
d12	3FCCh	-	Speed Control Jogging I Integral Time	7	-
d13	3FCDh	-	Speed Control Jogging Output Filter	7	-
d14	3FCEh	-	Input Terminal [PIA][PIB] Pulse Input Format Selection	1	-
d15	3FCFh	-	Input Terminal [PIA][PIB] Encoder Pulse Resolution	1	-
d16	3FD0h	-	Input Terminal [PIA][PIB] Pulse Scaling Factor Denominator	1	-
d17	3FD1h	-	Input Terminal [PIA][PIB] Pulse Scaling Factor Numerator	1	-
d18	3FD2h	-	Input Terminal [PIA][PIB] Pulse Train Filter Time Constant	7	-
d21	3FD5h	-	Speed Agreement / Speed Deviation Error Hysteresis Width	3	-
d22	3FD6h	-	Speed Agreement / Speed Deviation Error Detection Timer	5	-



Parameter No.	MODBUS address (MSB)	MODBUS address (LSB)	Parameter name	Communication data format (during single-word access)	Communication data format (during double-word access)
d23	3FD7h	-	Speed Deviation Error Processing Selection	1	-
d24	3FD8h	-	Zero Speed Control	1	-
d25	3FD9h	-	Speed Control Speed Loop Switching Time at Parameter Change	7	-
d32	3FE0h	3FE1h	Speed Limit 1 in Forward	1	1
d33	3FE2h	3FE3h	Speed Limit 2 in Reverse	1	1
d35	3FE5h	-	Over Speed Detection Level	1	-
d41	3FEBh	-	Special Control Selection	1	-
d51	3FF5h	-	Reserved	2	-
d52	3FF6h	-	Reserved	2	-
d55	3FF9h	-	Reserved	1	-
d59	3FFDh	-	Reserved	1	-
d60	3FFEh	-	Reserved	1	-
d61	3FFFh	-	Reserved	7	-
d62	4000h	-	Reserved	1	-
d63	4001h	-	Reserved	1	-
d67	4005h	-	Motor Starting Mode Auto Search in Speed Sensor less Vector Control	1	-
d68	4006h	-	Reserved	3	-
d70	4008h	-	Speed Control Slip Frequency Limit	5	-
d71	4009h	-	Reserved	5	-
d72	400Ah	-	Reserved	5	-
d73	400Bh	-	Reserved	1	-
d74	400Ch	-	Reserved	1	-
d75	400Dh	-	Reserved	5	-
d76	400Eh	-	Reserved	1	-
d77	400Fh	-	Reserved	1	-
d78	4010h	-	Reserved	1	-
d79	4011h	-	Reserved	1	-
d80	4012h	-	1st PM Motor Magnetic Pole Position Pull-in Frequency	3	-
d81	4013h	-	Reserved	1	-
d82	4014h	-	Magnetic Flux Weakening Control Function Selection	1	-
d83	4015h	-	Magnetic Flux Weakening Lower Limit	1	-
d84	4016h	-	Reserved	1	-
d85	4017h	-	Reserved	1	-
d86	4018h	-	Acc/Dec Output Frequency Filter	7	-
d88	401Ah	-	Reserved	5	-

Parameter No.	MODBUS address (MSB)	MODBUS address (LSB)	Parameter name	Communication data format (during single-word access)	Communication data format (during double-word access)
d89	401Bh	-	PM Motor High-efficiency Control Selection	1	-
d90	401Ch	-	Magnetic Flux Level during Deceleration	1	-
d91	401Dh	-	Reserved	5	-
d92	401Eh	-	Reserved	5	-
d93	401Fh	-	Reserved	5	-
d94	4020h	-	Reserved	5	-
d95	4021h	-	Reserved	5	-
d96	4022h	-	Reserved	4	-
d97	4023h	-	Reserved	4	-
d98	4024h	-	Reserved	1	-
d99	4025h	-	Extension Function 1	1	-
d190	40DAh	-	Reserved	1	-
d192	40DCh	-	Reserved	5	-
d198	40E2h	-	Reserved	1	-
d201	4141h	-	Position Control Feed Forward Gain	5	-
d202	4142h	-	Position Control Feed Forward Filter	7	-
d203	4143h	-	Position Loop Gain 1	3	-
d204	4144h	-	Position Loop Gain 2	3	-
d205	4145h	-	Position Loop Gain Switch Frequency	3	-
d206	4146h	-	Electronic Gear Denominator	1	-
d207	4147h	-	Electronic Gear Numerator	1	-
d208	4148h	-	Orientation Selection	1	-
d209	4149h	-	Homing Operation Selection	1	-
d211	414Bh	-	Homing Reference Signal Selection	1	-
d212	414Ch	-	Reference Signal for Homing Offset	1	-
d213	414Dh	-	Homing Frequency/Orientation Frequency	3	-
d214	414Eh	-	Creep Frequency	3	-
d215	414Fh	-	Deceleration Time for Homing/Orientation	12	-
d220	4154h	-	Position Feedback Store Selection at Power Off	1	-
d221	4155h	-	Current Position Clear Signal Operation Selection	1	-
d222	4156h	-	Overtravel Function Selection	1	-
d223	4157h	-	Detection Level of Excessive Positioning Deviation (MSB)	1	-

Parameter No.	MODBUS address (MSB)	MODBUS address (LSB)	Parameter name	Communication data format (during single-word access)	Communication data format (during double-word access)
d224	4158h	-	Detection Level of Excessive Positioning Deviation (LSB)	1	-
d225	4159h	-	Software Overtravel Detection Position in the Positive Direction (MSB)	2	-
d226	415Ah	-	Software Overtravel Detection Position in the Positive Direction (LSB)	1	-
d227	415Bh	-	Software Overtravel Detection Position in the Negative Direction (MSB)	2	-
d228	415Ch	-	Software Overtravel Detection Position in the Negative Direction (LSB)	1	-
d237	4165h	-	Positioning Data Type	1	-
d238	4166h	-	Position Data Determination Time	7	-
d239	4167h	-	Positioning Completed Range	1	-
d240	165Fh	-	Preset Position (MSB)	2	-
d241	1660h	-	Preset Position (LSB)	1	-
d242	416Ah	-	Homing Offset (MSB)	1	-
d243	416Bh	-	Homing Offset (LSB)	1	-
d244	163Dh	-	Positioning Data 1 (MSB)	2	-
d245	163Eh	-	Positioning Data 1 (LSB)	1	-
d246	163Fh	-	Positioning Data 2 (MSB)	2	-
d247	1640h	-	Positioning Data 2 (LSB)	1	-
d248	1641h	-	Positioning Data 3 (MSB)	2	-
d249	1642h	-	Positioning Data 3 (LSB)	1	-
d250	1643h	-	Positioning Data 4 (MSB)	2	-
d251	1644h	-	Positioning Data 4 (LSB)	1	-
d252	1645h	-	Positioning Data 5 (MSB)	2	-
d253	1646h	-	Positioning Data 5 (LSB)	1	-
d254	1647h	-	Positioning Data 6 (MSB)	2	-
d255	1648h	-	Positioning Data 6 (LSB)	1	-
d256	1649h	-	Positioning Data 7 (MSB)	2	-
d257	164Ah	-	Positioning Data 7 (LSB)	1	-
d258	164Bh	-	Positioning Data 8 (MSB)	2	-
d259	164Ch	-	Positioning Data 8 (LSB)	1	-
d277	418Dh	-	Positioning Data Setting Selection via communication	1	-
d278	418Eh	-	Restarting Positioning Range Setting	1	-
d280	4190h	-	Over Travel Forced Stop Operation Selection	1	-

Parameter No.	MODBUS address (MSB)	MODBUS address (LSB)	Parameter name	Communication data format (during single-word access)	Communication data format (during double-word access)
d296	1035h	-	Current Reference Position Monitor (MSB)	2	-
d297	1036h	-	Current Reference Position Monitor (LSB)	1	-
d298	1037h	-	Current Feedback Position Monitor (MSB)	2	-
d299	1038h	-	Current Feedback Position Monitor (LSB)	1	-
y11	420Bh	-	RS-485 Communication Station No. Selection	1	-
y12	420Ch	-	Operation Selection on Communication Error	1	-
y13	420Dh	-	RS-485 Error Detection Timer	3	-
y14	420Eh	-	RS-485 Communication Baud Rate	1	-
y16	4210h	-	RS-485 Communication Parity Bit Selection	1	-
y18	4212h	-	RS-485 Communication Timeout Time	1	-
y19	4213h	-	RS-485 Communication Response Interval Time	5	-
y95	425Fh	-	Data Clear Processing for Communications Error	1	-
y97	4261h	-	Communication Data Storage Selection	1	-
y99	4263h	-	Support Tool Link Function Selection	1	-
S01	5001h	-	Frequency Reference	29	-
S02	5002h	-	Torque Reference	6	-
S03	5003h	-	Torque Current Command	6	-
S05	5005h	5006h	Frequency Reference	22	5
S06	5007h	-	Operation command	14	-
S07	5008h	-	Communication Data Terminal [DO]	15	-
S12	500Dh	-	Communication Data Terminal [AO]	29	-
S13	500Eh	-	PID Control PID Command via Communication	29	-
S14	500Fh	-	Alarm Reset Command	1	-
S15	5010h	-	Torque Bias Value via Communication	6	-
S19	5014h	-	Speed Command via Communication	2	-
S20	5015h	-	Positioning Data via Communication (MSB)	2	-

Parameter No.	MODBUS address (MSB)	MODBUS address (LSB)	Parameter name	Communication data format (during single-word access)	Communication data format (during double-word access)
S21	5016h	-	Positioning Data via Communication (LSB)	1	-
S22	1621h	-	Torque Reference via Communication	2	-
S23	5018h	-	Torque Current Command via Communication	2	-
S24	1624h	-	Torque Bias Value via Communication	2	-
S30	501Fh	-	PID Control Feedback Value via Communication	29	-
M01	50C1h	-	Frequency Reference at Final	29	-
M02	50C2h	-	Torque Reference Monitor at Last	6	-
M03	50C3h	-	Torque Current Command at Final	6	-
M04	50C4h	-	Magnetic Flux Command Value	6	-
M05	50C5h	50C6h	Frequency Reference at Final	22	5
M06	50C7h	-	Output Frequency 1 without Slip Compensation	29	-
M07	50C8h	-	Torque Value	6	-
M08	50C9h	-	Torque Current Value	6	-
M09	50CAh	50CBh	Output Frequency without Slip Compensation	22	5
M10	50CCh	-	Input Power	5	-
M11	50CDh	-	Output Current Monitor	5	-
M12	50CEh	-	Output Voltage Monitor	3	-
M13	50CFh	-	Operation Command at Final	14	-
M14	50D0h	-	Operation Status 1 Monitor	16	-
M15	50D1h	-	Output Terminal Monitor	15	-
M16	0011h	-	Latest Alarm Contents	10	-
M17	001Bh	-	Last Alarm Contents	10	-
M18	0025h	-	Second Last Alarm Contents	10	-
M19	002Fh	-	Third Last Alarm Contents	10	-
M20	50D6h	50D7h	Cumulative Operation Time	1	1
M21	50D8h	-	Main Circuit DC Voltage	1	-
M25	50DCh	-	ROM Version	35	-
M26	50DDh	-	Transmission Error Transaction Code for RS-485 Port1	20	-
M27	50DEh	-	Final Frequency Reference Monitor on Alarm Monitor	29	-
M28	50DFh	-	Final Torque Command Monitor on Alarm	6	-
M29	50E0h	-	Final Torque Current Command Monitor on Alarm	6	-

Parameter No.	MODBUS address (MSB)	MODBUS address (LSB)	Parameter name	Communication data format (during single-word access)	Communication data format (during double-word access)
M30	50E1h	-	Final Magnetic flux command Monitor on Alarm	6	-
M31	50E2h	50E3h	Cumulative Operation Time	22	5
M32	50E4h	-	Output Frequency Monitor on Alarm without Slip Compensation	29	-
M33	50E5h	-	Output Torque Monitor on Alarm	6	-
M34	50E6h	-	Torque Current Monitor on Alarm	6	-
M35	50E7h	50E8h	Output Frequency Monitor on Alarm	22	5
M36	50E9h	-	Input Power Monitor on Alarm	5	-
M37	50EAh	-	Output Current Effective Value Monitor on Alarm	5	-
M38	50EBh	-	Output Voltage Effective Value Monitor on Alarm	3	-
M39	50ECh	-	Operation Command Monitor on Alarm	14	-
M40	50EDh	-	Operation Status 1 Monitor on Alarm	16	-
M41	50EEh	-	Latest Output Terminal Information Monitor on Alarm	15	-
M42	5123h	5124h	Cumulative Operation Time Monitor on Alarm	1	1
M43	50F0h	-	Main Circuit DC Voltage Monitor on Alarm	1	-
M44	50F1h	-	Inverter Internal Air Temperature Monitor on Alarm	2	-
M45	50F2h	-	Heat Sink Temperature Monitor on Alarm	2	-
M46	50F3h	-	Life of Main Circuit Capacitor Monitor	3	-
M47	50F4h	-	Life of PC Board Electrolytic Capacitor	74	-
M48	50F5h	-	Life of Cooling Fan	74	-
M49	50F6h	-	Input Terminal [AI1] Input Voltage Monitor	29	-
M50	50F7h	-	Input Terminal [AI2] Input Current (AI) Monitor	29	-
M54	50FBh	-	Input Terminal [AI2] Input Voltage (AIV) Monitor	29	-
M56	50FDh	-	Input Terminal [PTC] Input Voltage Monitor	29	-
M57	50FEh	-	Electric Angle Monitor	3	-
M58	50FFh	-	Rotor Angle Monitor	3	-

Parameter No.	MODBUS address (MSB)	MODBUS address (LSB)	Parameter name	Communication data format (during single-word access)	Communication data format (during double-word access)
M59	5100h	-	Motor Electronic Thermal Monitor	1	-
M61	5102h	-	Inverter Internal Air Temperature Monitor	4	-
M62	1018h	-	Fin Temperature Monitor	4	-
M63	5104h	-	Load Factor Monitor	6	-
M64	5105h	-	Motor Output Monitor	6	-
M65	5106h	-	Motor Output Monitor on Alarm	29	-
M66	5107h	-	Speed Detection Monitor	29	-
M67	5108h	-	Transmission Error Transaction Code for RS485 Port	20	-
M68	5109h	-	Reserved	29	-
M69	510Ah	-	Inverter Rated Current	19	-
M70	510Bh	-	Running Status 3 Monitor	44	-
M71	510Ch	-	Input Terminal Monitor	14	-
M72	510Dh	-	Reserved	29	-
M73	510Eh	-	PID Output Monitor	29	-
M74	510Fh	-	Running Status 2 Monitor	76	-
M76	5111h	-	Service Life of Main Circuit Capacitor Elapsed Time	74	-
M77	5112h	-	Service Life of Main Circuit Capacitor Remaining Time	74	-
M78	5113h	-	Rotation Speed Command Monitor	2	-
M79	5114h	5115h	Rotation Speed Monitor	2	2
M81	5117h	-	1st Remaining Time before the Next Motor Maintenance	74	-
M84	100Ch	-	Torque Command at Final	2	-
M85	511Bh	-	1st Remaining Startup Times before the Next Motor Maintenance	1	-
M86	511Ch	-	Latest Light Alarm Factor	41	-
M87	511Dh	-	Light Alarm Factor Last	41	-
M88	511Eh	-	Light Alarm Factor 2nd Last	41	-
M89	511Fh	-	Light Alarm Factor 3rd Last	41	-
M95	5125h	5126h	Cumulative Running Time at Tripping	1	1
M96	0039h	-	Fourth Last Alarm Contents	10	-
M97	0043h	-	Fifth Last Alarm Contents	10	-
M98	5129h	-	Warning status monitor	1	-
M114	519Bh	519Ch	Reserved	12	6
M115	519Dh	-	PID Output Non Filter	4	-
W01	1003h	-	Running Status 1 Monitor	16	-
W02	5242h	5243h	Frequency Reference Monitor	22	5

Parameter No.	MODBUS address (MSB)	MODBUS address (LSB)	Parameter name	Communication data format (during single-word access)	Communication data format (during double-word access)
W03	5244h	5245h	Output Frequency Monitor before Slip Compensation	22	5
W04	5246h	5247h	Output Frequency after Slip Compensation	22	5
W05	1002h	-	Output Current Monitor	19	-
W06	1010h	-	Output Voltage Monitor	3	-
W07	100Fh	-	Output Torque Monitor	2	-
W08	524Bh	524Ch	Rotate Speed Monitor	37	5
W09	524Dh	-	Load Shaft Speed	37	-
W10	524Eh	524Fh	Feed Speed	37	5
W11	5250h	-	PID Process Command	12	-
W12	1004h	1005h	PID Feedback Value Monitor	12	6
W13	5253h	-	Torque Limit Value A Monitor	2	-
W14	5254h	-	Torque Limit Value B Monitor	2	-
W15	5255h	-	Ratio value Monitor	5	-
W16	5256h	-	Motor Speed Set Value	37	-
W17	5257h	-	Load Shaft Set Value	37	-
W18	5258h	-	Feed Speed Set Value	37	-
W19	5259h	-	Transport Time Set Value for Specified Length	37	-
W20	525Ah	-	Transport Time for Specified Length	37	-
W21	525Bh	-	Power Consumption Monitor	24	-
W22	525Ch	-	Motor Output Power Monitor	24	-
W23	525Dh	-	Load Rate Monitor	2	-
W24	525Eh	-	Torque Current Monitor	2	-
W25	525Fh	-	Output Current Monitor	3	-
W26	5260h	-	Magnetic Flux Command Value	2	-
W27	5261h	-	Timed Operation Remaining Time	1	-
W28	1059h	-	RUN Command Source Monitor	67	-
W29	1058h	-	Frequency and PID Command Source Monitor	68	-
W30	5264h	-	Speed in Percentage	5	-
W31	5265h	-	Speed Set Value in Percentage	5	-
W32	10B1h	10b2h	PID Output Monitor	6	6
W33	5267h	-	Analog Input Monitor	12	-
W40	1006h	-	Input Terminal Monitor	43	-
W41	1007h	-	Output Signal Monitor	15	-
W42	5270h	-	Communications Input Signal Monitor	14	-



Parameter No.	MODBUS address (MSB)	MODBUS address (LSB)	Parameter name	Communication data format (during single-word access)	Communication data format (during double-word access)
W43	5271h	-	Communications Control Output Signal Monitor	15	-
W44	5272h	-	Input Terminal [AI1] Input Voltage	4	-
W45	5273h	-	Input Terminal [AI2] All Input Current (All)	4	-
W46	5274h	-	Output Terminal [AO] AOV Output Voltage	4	-
W48	5276h	-	Output Terminal [AO] PO Output Frequency	1	-
W49	5277h	-	Input Terminal [AI2] Input Voltage (AIV)	4	-
W50	5278h	-	Terminal [AO] (AOI) output current	3	-
W55	527Dh	-	Pulse Input (A/B Phase [PIA] [PIB])	6	-
W56	527Eh	-	Pulse Input (Z Phase [PIZ])	1	-
W57	527Fh	-	Reserved	73	-
W58	5280h	-	Reserved	1	-
W59	5281h	-	Reserved	73	-
W60	5282h	-	Reserved	1	-
W61	5283h	-	Reserved	73	-
W62	5284h	-	Reserved	1	-
W63	5285h	-	Reserved	1	-
W66	5288h	-	Reserved	4	-
W67	5289h	-	Cumulative Run Time of Capacitors on Printed Circuit Boards	74	-
W68	528Ah	-	Cumulative Run Time of Cooling Fan	74	-
W70	528Ch	528Dh	Total Power ON Time Monitor	1	1
W71	1025h	-	Main circuit DC voltage Monitor	3	-
W72	528Fh	-	Internal Air Highest Temperature	2	-
W73	5290h	-	Heat Sink Maximum Temperature	2	-
W74	5291h	-	Maximum Effective Current Value	19	-
W75	5292h	-	Main Circuit Capacitor's Capacitor Monitor	3	-
W76	1016h	1017h	Cumulative Run Time of Electrolytic Capacitors on PC Board	1	1
W77	5295h	5296h	Cumulative Run Time of Cooling Fan	1	1

Parameter No.	MODBUS address (MSB)	MODBUS address (LSB)	Parameter name	Communication data format (during single-word access)	Communication data format (during double-word access)
W78	5297h	-	Number of Startups	1	-
W79	5298h	5299h	Cumulative Operation Time of Motor	1	1
W81	529Bh	529Ch	Integrated Power Monitor	93	3
W82	1012h	1013h	Data Used Integrating Electric Power	45	3
W83	529Fh	-	Number of Operator Comm Errors	1	-
W84	52A0h	-	Contents of Operator Comm error	20	-
W85	52A1h	-	Number of RS-485 Errors	1	-
W86	52A2h	-	Reserved	1	-
W87	52A3h	-	Inverter ROM Version 1 Main	1	-
W88	52A4h	-	Inverter ROM Version 2 Sub	1	-
W89	52A5h	-	ROM Version Operator	1	-
W90	52A6h	-	Reserved	1	-
W91	52A7h	-	ROM Version ECT Terminal Board 2	1	-
W94	52AAh	-	Contents of RS-485 Error	20	-
W95	52ABh	-	Reserved	1	-
W96	52ACh	-	Reserved	1	-
W97	52ADh	-	Contents of ECT Terminal Board error	1	-
W110	530Ah	-	Motor Speed	37	-
W111	530Ch	-	Load Shaft Speed	37	-
W115	5314h	-	Output Frequency After Slip Compensation	22	-
W116	5316h	-	PG Feedback Value	22	-
W118	100Dh	-	Torque Bias Monitor	2	-
W131	10ADh	10AEh	PID Control PID Deviation (After Scale Transformation)	12	6
W132	5321h	-	PID Control PID Deviation (No Scale Transformation)	29	-
W135	1011h	-	Input Power Monitor	3	-
W136	108Dh	-	Input Terminal [AI1] Input Voltage (AIV)	2	-
W137	108Eh	-	Input Terminal [AI2] Input Current (AII)	1	-
W138	5327h	-	Input Terminal [AI2] Input Voltage (AIV)	1	-
W139	1090h	-	Pulse Train Frequency Monitor	6	-
W142	532Bh	-	Feedback Current Position Monitor (MSB)	2	-
W143	532Ch	-	Feedback Current Position Monitor (LSB)	1	-

Parameter No.	MODBUS address (MSB)	MODBUS address (LSB)	Parameter name	Communication data format (during single-word access)	Communication data format (during double-word access)
W144	532Dh	-	Target Position Monitor (MSB)	2	-
W145	532Eh	-	Target Position Monitor (LSB)	1	-
W146	532Fh	-	Position Deviation Monitor (MSB)	2	-
W147	5330h	-	Position Deviation Monitor (LSB)	1	-
W148	5331h	-	Touch Probe 1 Positive Edge (MSB)	2	-
W149	5332h	-	Touch Probe 1 Positive Edge (LSB)	1	-
W150	5333h	-	Touch Probe 2 Positive Edge (MSB)	2	-
W151	5334h	-	Touch Probe 2 Positive Edge (LSB)	1	-
W152	5335h	-	Touch Probe Status	1	-
W153	5336h	-	Pulse Input Rate for A/B Phase of Reference Side	6	-
W154	5337h	-	Pulse Input Rate for Z Phase of Reference Side	1	-
W155	5338h	-	Pulse Input Rate for A/B Phase of Feedback Side	6	-
W156	5339h	-	Pulse Input Rate for Z Phase of Feedback Side	1	-
W161	533Eh	-	Braking Resistor Thermal Monitor	3	-
W178	534Fh	-	Number of Startups	5	-
W179	1014h	1015h	Total RUN Time Monitor	1	1
W180	5351h	-	Tuning Progress	1	-
W202	53C2h	-	Reserved	12	-
W203	53C3h	-	Reserved	12	-
X00	5540h	-	Latest Alarm History/Number of Consecutive Same Alarms	41	-
X01	5541h	-	Latest Multiple Alarm1	10	-
X02	5542h	-	Latest Multiple Alarm2	10	-
X03	5543h	-	Latest Alarm Sub Code 1	1	-
X04	5544h	-	Latest Multiple Alarm Sub Code 2	1	-
X05	5545h	-	Last Alarm History/Number of Consecutive Same Alarms	41	-
X06	5546h	-	Last Multiple Alarm 2	10	-
X07	5547h	-	Last Multiple Alarm 3	10	-
X08	5548h	-	Last Alarm Sub Code 1	1	-
X09	5549h	-	Last Multiple Alarm Sub Code	1	-
X10	554Ah	-	Second Last Alarm History/ Number of Consecutive Same Alarms	41	-

Parameter No.	MODBUS address (MSB)	MODBUS address (LSB)	Parameter name	Communication data format (during single-word access)	Communication data format (during double-word access)
X11	554Bh	-	Second last Multiple Alarm2	10	-
X12	554Ch	-	Second Last Multiple Alarm3	10	-
X13	554Dh	-	Second Last Alarm Sub Code	1	-
X14	554Eh	-	Second Last Multiple Alarm Sub Code	1	-
X15	554Fh	-	Third Last Alarm History/ Number of Consecutive Same Alarms	41	-
X16	5550h	-	Third Last Multiple Alarm 2	10	-
X17	5551h	-	Third Last Multiple Alarm 3	10	-
X18	5552h	-	Third Last Alarm Sub Code 1	1	-
X19	5553h	-	Third Last Multiple Alarm Sub Code 2	1	-
X20	0013h	0014h	Latest Alarm Info. Output Frequency	22	5
X21	0015h	-	Latest Alarm Info. Output Current	19	-
X22	5557h	-	Latest Alarm Info. Output Voltage	1	-
X23	5558h	-	Latest Alarm Info. Torque Monitor	2	-
X24	5559h	555Ah	Latest Alarm Info. Frequency Command	22	5
X25	0012h	-	Latest Alarm Info. Running Status 1	16	-
X26	0019h	001Ah	Latest Alarm Info. Cumulative Ope. time	1	1
X27	555Dh	-	Latest Alarm Info. Number of Startups	1	-
X28	0016h	-	Latest Alarm Info. Main Circuit DC Voltage	3	-
X29	555Fh	-	Latest Alarm Info. Internal Air Temperature	2	-
X30	5560h	-	Latest Alarm Info. Heat Sink Temperature	2	-
X31	5561h	-	Latest Alarm Info. Input Terminal	43	-
X32	5562h	-	Latest Alarm Info. Output Terminal	15	-
X33	5563h	-	Latest Alarm Info. Input Terminal via Communication	14	-
X34	5564h	-	Latest Alarm Info. Output Terminal via Communication	15	-
X35	5565h	-	Latest Alarm Info. Input Power	24	-
X36	5566h	-	Latest Alarm Info. Running Status 2	76	-

Parameter No.	MODBUS address (MSB)	MODBUS address (LSB)	Parameter name	Communication data format (during single-word access)	Communication data format (during double-word access)
X37	5567h	-	Latest Alarm Info. Speed Detection	29	-
X38	5568h	-	Latest Alarm Info. Running Status 3	44	-
X49	5573h	-	Fault Counter	1	-
X60	001Dh	001Eh	Last Info. Alarm Info. Output Frequency	22	5
X61	001Fh	-	Last Alarm Info. Output Current	19	-
X62	5581h	-	Last Alarm Info. Output Voltage	1	-
X63	5582h	-	Last Alarm Info. Torque Monitor	2	-
X64	5583h	5584h	Last Alarm Info. Frequency Command	22	5
X65	001Ch	-	Last Alarm Info. Running Status	16	-
X66	0023h	0024h	Last Alarm Info. Cumulative Ope. Time	1	1
X67	5587h	-	Last Alarm Info. Number of Startups	1	-
X68	0020h	-	Last Alarm Info. Main Circuit DC Voltage	3	-
X69	5589h	-	Last Alarm Info Internal Air Temperature	2	-
X70	558Ah	-	Last Alarm Info. Heat Sink Temperature	2	-
X71	558Bh	-	Last Alarm Info. Input Terminal	43	-
X72	558Ch	-	Last Alarm Info. Output Terminal	15	-
X73	558Dh	-	Last Alarm Info. Input Terminal via Communication	14	-
X74	558Eh	-	Last Alarm Info. Output Terminal via Communication	15	-
X76	5590h	-	Last Alarm Info. Running Status 2	76	-
X77	5591h	-	Last Alarm Info. Speed Detection	29	-
X78	5592h	-	Last Alarm Info. Running Status 3	44	-
X97	55A5h	-	Input Input Terminal [PTC] Input Voltage	4	-
X108	0017h	0018h	Latest Alarm Info. Cumulative Running Time	1	1
X118	0021h	0022h	Last Alarm Info. Cumulative Running Time	1	1

Parameter No.	MODBUS address (MSB)	MODBUS address (LSB)	Parameter name	Communication data format (during single-word access)	Communication data format (during double-word access)
X128	002Bh	002Ch	Second last Alarm Info. Cumulative Running Time	1	1
X138	0035h	0036h	Third last Alarm Info. Cumulative Running Time	1	1
X140	5628h	-	4th last Alarm History/Number of Consecutive Same Alarms	41	-
X141	003Bh	003Ch	Fourth last Alarm Info. Output Frequency	22	5
X142	003Dh	-	Fourth last Alarm Info. Output Current	19	-
X143	0041h	0042h	Fourth Last Alarm Info. Cumulative Ope. time	1	1
X144	003Eh	-	Fourth Last Alarm Info. Main Circuit DC Voltage	3	-
X148	003Fh	0040h	Fourth Last Alarm Info. Cumulative Running Time	1	1
X149	003Ah	-	Fourth Last Alarm Info. Running Status	16	-
X150	5632h	-	5th last Alarm History/Number of Consecutive Same Alarms	41	-
X151	0045h	0046h	Fifth Last Alarm Info. Output Frequency	22	5
X152	0047h	-	Fifth Last Alarm Info. Output Current	19	-
X153	004Bh	004Ch	Fifth Last Alarm Info. Cumulative Ope. Time	1	1
X154	0048h	-	Fifth last Alarm Info. Main Circuit DC Voltage	3	-
X158	0049h	004Ah	Fifth last Alarm Info. Cumulative Running time	1	1
X159	0044h	-	Fifth Last Alarm Info. Running Status	16	-
Z00	0027h	0028h	Second Last Alarm Info. Output Frequency	22	5
Z01	0029h	-	Second Last Alarm Info. Output Current	19	-
Z02	5783h	-	Second Last Alarm Info. Output Voltage	1	-
Z03	5784h	-	Second Last Alarm Info. Torque Monitor	2	-
Z04	5785h	5786h	Second Last Alarm Info. Frequency Command	22	5
Z05	0026h	-	Second Last Alarm Info. Running Status	16	-
Z06	002Dh	002Eh	Second Last Alarm Info. Cumulative Ope. Time	1	1

Parameter No.	MODBUS address (MSB)	MODBUS address (LSB)	Parameter name	Communication data format (during single-word access)	Communication data format (during double-word access)
Z07	578Ah	-	Second Last Alarm Info. Number of Startups	1	-
Z08	002Ah	-	Second Last Alarm Info. Main Circuit DC Voltage	3	-
Z09	578Ch	-	Second Last Alarm Info. Internal Air Temperature	2	-
Z10	578Dh	-	Second Last Alarm Info. Heat Sink Temperature	2	-
Z11	578Eh	-	Second Last Alarm Info. Input Terminal	43	-
Z12	578Fh	-	Second Last Alarm Info. Output Terminal	15	-
Z13	5790h	-	Second Last Alarm Info. Input Terminal via Communication	14	-
Z14	5791h	-	Second Last Alarm Info. Output Terminal via Communication	15	-
Z16	5793h	-	Second Last Alarm Info. Running Status 2	76	-
Z17	5794h	-	Second Last Alarm Info. Speed Detection	29	-
Z18	5795h	-	Second Last Alarm Info. Running Status 3	44	-
Z40	57ADh	-	1st Cumulative Run Time	74	-
Z41	57AEh	-	2nd Cumulative Run Time of motor	74	-
Z44	57AFh	-	2nd Number of Startups	1	-
Z50	0031h	0032h	Third Last Alarm Info. Output Frequency	22	5
Z51	0033h	-	Third Last Alarm Info. Output Current	19	-
Z52	57B8h	-	Third Last Alarm Info. Output Voltage	1	-
Z53	57B9h	-	Third Last Alarm Info. Torque Monitor	2	-
Z54	57BAh	57BBh	Third Last Alarm Info. Frequency Command	22	5
Z55	0030h	-	Third Last Alarm Info. Running Status	16	-
Z56	0037h	0038h	Third Last Alarm Info. Cumulative Ope. Time	1	1
Z57	57BFh	-	Third Last Alarm Info. Number of Startups	1	-
Z58	0034h	-	Third Last Alarm Info. Main Circuit DC Voltage	3	-
Z59	57C1h	-	Third Last Alarm Info. Internal Air Temperature	2	-

Parameter No.	MODBUS address (MSB)	MODBUS address (LSB)	Parameter name	Communication data format (during single-word access)	Communication data format (during double-word access)
Z60	57C2h	-	Third Last Alarm Info. Heat Sink Temperature	2	-
Z61	57C3h	-	Third Last Alarm Info. Input Terminal	43	-
Z62	57C4h	-	Third Last Alarm Info. Output Terminal	15	-
Z63	57C5h	-	Third Last Alarm Info. Input Terminal via Communication	14	-
Z64	57C6h	-	Third Last Alarm Info. Output Terminal via Communication	15	-
Z66	57C8h	-	Third Last Alarm Info. Running Status 2	76	-
Z67	57C9h	-	Third Last Alarm Info. Speed Detection	29	-
Z68	57CAh	-	Third Last Alarm Info. Running Status 3	44	-
Z84	57DAh	-	Output Current Monitor	19	-



## 8-10 Command via Communications

The RUN command and Frequency Reference can be instructed via communication.

The RUN command and Frequency Reference are input according to the command value set to parameter S.

Reading and writing to parameter S is performed by accessing the coil No. or register No. of the applicable Modbus communication. (Refer to 8-9 Modbus Communication Data Lists on page 8-34.)

Priority can forcibly be given to commands via communication also when a command other than via communication is currently selected.

### 8-10-1 RUN Command via Communications

To input the RUN command via communications, select “4: RS-485 communication” at RUN Command Selection (F02/E102).

The operation is performed according to the Forward command (FWD) or Reverse command (REV) from Operation command (S06).

Parameter No.	Function name	Data	Default data	Unit
F02 E102	1st RUN Command Selection 2nd RUN Command Selection*1	4: RS-485 communication	2	-
S06	Operation command	Bit1: REV Bit0: FWD	0	-
Related function		Input Terminal [DI6] Function Selection (E98), Input Terminal [DI7] Function Selection (E99) Refer to 5-9-1 Input Terminal Functions on page 5-51.		

\*1. To enable switching to the 1st and 2nd control, allocate “12: SET (2nd control)” to either of input terminal [DI1] to [DI7].

### 8-10-2 Frequency Reference via Communications

To input the Frequency Reference via communications, select “14: RS-485 communication” at Frequency Reference Selection (F01/C30).

- The Frequency Reference can be set in three formats via Modbus communication and the USB communication.

Frequency Reference (S01):	Value obtained by converting $\pm 20000$ as the Maximum Output Frequency (F03/A01)
Frequency Reference (S05):	Value in 0.01 Hz units
Speed Command via Communication (S19):	Value in 1 r/min units

- Compensation values can be set for the frequency setting via communication at Set-point Factor Numerator via Communication (C89) and Set-point Factor Denominator via Communication (C90).

$$\text{Frequency reference} = \frac{\text{Frequency setting via communications}}{\text{C90: Set-point Factor Denominator via Communication}} \times \frac{\text{C89: Set-point Factor Numerator via Communication}}{\text{C90: Set-point Factor Denominator via Communication}}$$

Parameter No.	Function name	Data	Default data	Unit
F01	1st Frequency Reference Selection	14: RS-485 communication	0	-
C30	2nd Frequency Reference Selection *1		2	-
S01	Frequency Reference	-32,768 to 32,767 +20,000 or -20,000 = Maximum output frequency	0	-
S05	Frequency Reference	0.00 to 655.35 Hz	0.00	Hz
S19	Speed Command via Communication	-32768 to 32767	0	r/min
C89	Set-point Factor Numerator via Communication	-32768 to 32767	0	-
C90	Set-point Factor Denominator via Communication	-32768 to 32767	0	-

\*1. To enable switching to the 1st and 2nd control, allocate "12: SET (2nd control)" to either of input terminal [DI1] to [DI7].

- S01, S05 and S19 that are set via Modbus communication or USB communication are converted to the final set frequency with priority given to the last written value.

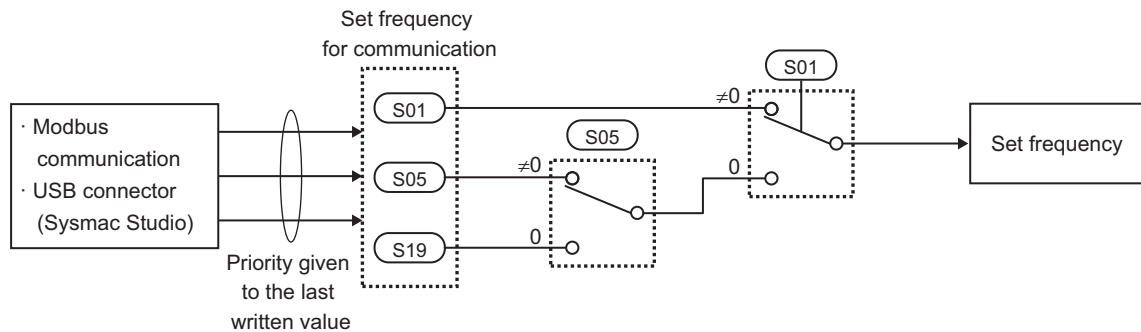

### 8-10-3 Forced Commands via Communication

To forcibly give priority to commands via communication also when a command other than via communication is currently selected, set Support Tool Link Function Selection (y99).

Parameter No.	Function name	Data	Default data	Unit
y99	Support Tool Link Function Selection	0: Numerical setting and terminal command (including operation command ) by related parameter settings 1: Numerical setting uses communications command (support tools) 2: Terminal setting uses communications command (support tools) 3: Both numerical setting and terminal command use communications command (support tools) Numerical setting means Frequency reference, torque command, or torque bias command.	0	-

## Disable Support Tool Link Function (y99 = 0)

This is activated by the command selected by RUN Command Selection (F02/E102) and Frequency Reference selection (F01/C30).

## Enable Support Tool Link Function Command Value (y99 = 1, 3)

This is instructed by setting Frequency Reference (S01)/Torque Reference (S02)/Torque Bias Value (S24) to the register No. of the applicable Modbus communication. (Refer to 8-9-2 *Register List* on page 8-36.)

Parameter No.	Function name	Data	Default data	Unit
S01	Frequency Reference	-32,768 to 32,767 +20,000 or -20,000 = Maximum output frequency	0	-
S02	Torque Reference	-327.68 to 327.67 %	0	%
S24	Torque Bias Value	-327 to 327 %	0	%

## Enable Support Tool Link Function Universal I/O Terminals (y99 = 2, 3)

- Input terminals [DI1] to [DI7], output terminals [DO1] to [DO2] and [ROA, ROB], and analog output terminal [AO] can be forcibly manipulated via communication by enabling universal I/O terminals.
- Normally, functions currently selected by Input Terminal [DI1] to [DI7] Function Selection can be operated not by signals that are input from input terminals [DI1] to [DI7] but by forcibly setting them via communication.
- Output to output terminals [DO1], [DO2] and [ROA, ROB] and analog output terminal [AO] by setting Communication Data Terminal [DO] (S07) and Communication Data Terminal [AO] (S12) and not the output signal selected by Output Terminal [DO1] to [DO2] and [ROA, ROB] Function Selection or Output Terminal [AO] Function Selection to the register No. of the applicable Modbus communication. (Refer to 8-9-2 *Register List* on page 8-36.)

Parameter No.	Function name	Data	Default data	Unit
S06	Operation command	Bit15: RST Bit14: DI7 Bit13: DI6 Bit12: --- Bit11: --- Bit10: --- Bit9: --- Bit8: --- Bit7: --- Bit6: DI5 Bit5: DI4 Bit4: DI3 Bit3: DI2 Bit2: DI1 Bit1: REV Bit0: FWD	0	-
S07	Communication Data Terminal [DO]	Bit15: --- Bit14: --- Bit13: --- Bit12: --- Bit11: --- Bit10: --- Bit9: --- Bit8: RO Bit7: --- Bit6: --- Bit5: --- Bit4: --- Bit3: --- Bit2: --- Bit1: DO2 Bit0: DO1	0	-
S12	Communication Data Terminal [AO]	-32,768 to 32,767	0	%



# Troubleshooting

This section describes how to analyze the cause and take countermeasures if the inverter fails, and provides troubleshooting for possible troubles.

---

<b>9-1</b>	<b>Alarm Display and Remedies .....</b>	<b>9-2</b>
9-1-1	Alarm Display .....	9-2
9-1-2	Alarm Code List .....	9-4
9-1-3	Minor Fault Code List .....	9-25
9-1-4	Other Display List .....	9-26
<b>9-2</b>	<b>Troubleshooting .....</b>	<b>9-28</b>

# 9-1 Alarm Display and Remedies

## 9-1-1 Alarm Display

If an error occurs, the inverter shuts off its output (“trip”), turns ON the ERROR LED, and displays an alarm code. After checking the RUN command and other signals, you can reset the alarm.

Before resetting the alarm, be sure to investigate the cause of the trip and remove the trip factor(s) according to the displayed alarm code.

This section describes how to deal with troubles that may occur after you start using the inverter.

### Fault Monitor Display

Use the Alarm List 1 to 6 (Program Mode  $\mathcal{E} \mathcal{A} \mathcal{L}$ ) to check the current alarm, as well as the past alarms.

The Alarm List 1 displays information on the latest alarm.

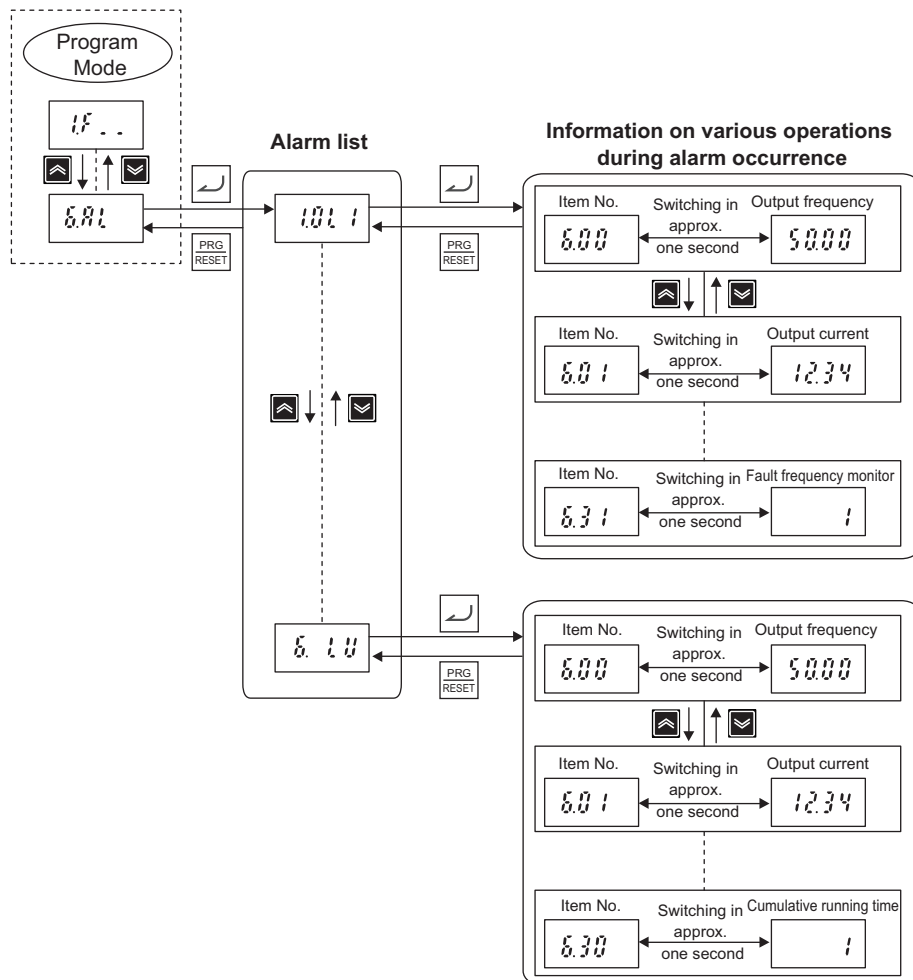

### How to Reset a Trip State

The inverter in a trip state can be reset in either of the following two methods.

- Press the  key on the digital operator.

The  key is enabled even when other than the operator is set in the 1st RUN Command Selection (F02)/2nd RUN Command Selection (E102).

- Input the reset signal via the control circuit terminal block.  
Set “8: RS (Reset)” to one of the Input Terminal [DI1] Function Selection to Input Terminal [DI7] Function Selection (E01 to E05, E98, E99).

The above reset methods may not be effective depending on the trip factor.  
In such cases, cycle the power supply.

## Data Clear Processing for Communications Error

Communications command parameter (S code) data can be automatically cleared when a communications error alarm (ErP) is generated with RS-485.







Clearing this will remove the frequency reference and RUN command, therefore the inverter will not start inadvertently when clearing the alarm.

Parameter No.	Function name	Data	Default data	Unit
y95	Data Clear Processing for Communications Error	0: Do not clear the data of function codes S when a communications error occurs. (compatible with the conventional inverters) 1: Clear the data of function codes S001, S005, and S019 when a communications error occurs 2: Clear the run command assigned bit of function code S06 when a communications error occurs 3: Clear both data 1 and 2 above	0	-



## 9-1-2 Alarm Code List

Alarm code	Alarm sub-code	Name	Description	Check point and remedy reference
<b>Cof</b> (Cof)	1	Current input terminal AI2(AI1) signal disconnection	(1) Current input command disconnection	Check that current input terminals AI2(AI1)* are receiving current. → Terminal AI2(AI1) disconnection detection "Subcode: 1"
			(2) Strong noise received from surrounds	Check measures against noise (grounding conditions, signal wiring and communication cable/main circuit wiring and installation methods, etc.) → Strengthen measures against noise. → Separate main circuit wiring and control circuit wiring as much as possible.
<b>dbA</b> (dbA)		Braking transistor error	Error in braking resistor connection terminal wiring	Check that the braking resistor is correctly wired in to the [P+] and [DB] terminals on the main circuit terminal block. Check that the motor wiring is not erroneously connected to the terminal [DB]. → If there is no miswiring, request repair of the inverter.
			The braking transistor is damaged.	Check that the braking resistor value is correct, and that it is not miswired. → If there is no problem, request repair of the inverter.
<b>dbH</b> (dbH)	0	Braking resistor overheating	(1) High braking load	Re-calculate the relationship between braking load calculations and braking capacity. → Reduce braking load. → Review braking resistor selection, and increase braking capacity. (Resetting of parameters F50, F51, F52 data is necessary)
	0		(2) Short deceleration time	Recalculate deceleration torque and deceleration time required from the moment of inertia of the load and deceleration time. → Lengthen deceleration time (parameters F08, E11, E13, E15, H56) → Review braking resistor selection, and increase braking capacity. (Resetting of parameters F50, F51, F52 data is necessary)



Alarm code	Alarm sub-code	Name	Description	Check point and remedy reference
 (ECF)		EN circuit failure	(1) Bad connection in control terminal block board	Check that the control terminal block board is firmly mounted in the inverter unit. → Cycle the power to clear the alarm.
			(2) Enable circuit logic failure	<ul style="list-style-type: none"> <li>Check that the output from the safety switch is input using the same logic (High/High or Low/Low) to both terminals [SF1]/[SF2].</li> <li>Check that both of the two poles of SW9 on the control board are turned ON/ON or OFF/OFF.</li> </ul> → The alarm is canceled through use of the  key or by cycling the power.
			(3) Enable circuit (safe stop circuit) damage (single failure) detected	If this is not resolved by the procedure above, the inverter is faulty. → Please contact OMRON.
 (Er1)		Memory error	(1) Power disconnected during parameter data writing (in particular during initialization and data copying) and control power dropped	Initialize data with Data Initialization (H03), and when complete, use the  key to check that the alarm can be canceled. → Restore the initialized parameter data, and restart operation.
			(2) During parameter data writing (in particular during initialization), strong noise received from surrounds	Check methods for measures against noise (grounding conditions, control/main circuit wiring and installation). Additionally, perform the same checks as in (1). → Perform measures against noise, restore the initialized parameter data, and restart operation.
			(3) Error occurred in control circuit	Initialize data with Data Initialization (H03), and when initialization is complete, use the  key to check if the alarm continues even when trying to cancel this. → Board (including CPU) error, so contact OMRON.
			(4) Power disconnected during saving of user settings with parameter H193, and control power dropped	Save user settings with parameter (H193), and when saving is complete, use the  key to check if the alarm continues even when trying to cancel this. → Board (including CPU) error, so contact OMRON.
			(5) During saving of user settings with parameter H193, strong noise received from surrounds	Check methods for measures against noise (grounding conditions, control/main circuit wiring and installation). Additionally, perform the same checks as in (4). → Board (including CPU) error, so contact OMRON.

Alarm code	Alarm sub-code	Name	Description	Check point and remedy reference
Er2 (Er2)		Digital Operator communications error	(1) Communications cable disconnection or bad connection	Check for cable continuity, contacts, or bad connections. → Check that connectors are correctly inserted. → Replace the communications cable.
			(2) Large numbers of control wires mean that the surface cover is not mounted securely, and the Digital Operator is floating	Check the mounting of the surface cover. → Reduce the wire size. (Recommended wire size (0.3 to 0.75 mm <sup>2</sup> )) → Change the routing of wiring within the unit so that the surface cover can be mounted securely.
			(3) Strong noise received from surrounds	Check methods for measures against noise (grounding conditions, communications cable/main circuit wiring and installation). → Implement measures against noise. (For details, refer to <i>2-3-4 Wiring for Main Circuit Terminals</i> on page 2-15.)
			(4) Digital Operator damage	Use a different Digital Operator to check if er2 occurs. → Replace the Digital Operator.
Er3 (Er3)		CPU error	(1) Strong noise received from surrounds	Check measures against noise (grounding conditions, signal wiring and communication cable/main circuit wiring and installation methods, etc.). → Improve measures against noise.

Alarm code	Alarm sub-code	Name	Description	Check point and remedy reference
Er6 (Er6)	1	Operation error	(1)  key is pressed while the  key is enabled (parameter H96=1, 3)	Check if the  key has been pressed while there is a RUN command in the terminal block or communication path. → If unintended operation, review parameter H96 settings.
	2 to 6		(2) With the start check function enabled (parameter H96=2,3), the start check function has operated	Check if the following operation has been performed while there is a RUN command input. <ul style="list-style-type: none"> <li>• Power supply ON</li> <li>• Alarm cancel</li> <li>• Switch to link RUN command</li> </ul> → With er6 occurring, review sequences, etc. so that a RUN command is not input. If unintended operation, review parameter H96 settings. (Before clearing the alarm, turn the RUN command OFF.)
	1		(3) Forced stop "STOP" (digital input terminal) turned OFF	Check if forced stop "STOP" has been turned OFF. → If unintended operation, review terminal DI1 to DI7 parameter E01 to E05, E98, E99 settings.
	8		(4) Brake check signal "BRKE" and brake control signal "BRKS" mismatch	Check that the signal input into the X terminal to which brake check signal "BRKE" is assigned and the brake control signal "BRKS" output from the Y terminal match. <ul style="list-style-type: none"> <li>• Signal disconnection</li> <li>• Check that the logic matches</li> <li>• If there is a delay, adjust the parameter H180 (brake control signal) time.</li> </ul>
	30		(5) A RUN command (FW/REV signals are ON) is input while the power recovery restart prevention (USP) signal is input	Check the power recovery restart prevention (USP) signal.

Alarm code	Alarm sub-code	Name	Description	Check point and remedy reference
Er7 (Er7)		Tuning error	(1) The connection between the inverter and the motor is missing phases	→ Ensure a correct connection between the inverter and motor.
			(2) V/f settings and motor rated current are not set correctly	Check that parameter (F04*, F05*, E166, E167, E169, E170, E171, E172, E173, E174, E175, E176, E177, E178, E179) data matches motor specifications.
			(3) Wiring between the inverter and motor is too long	Check that wiring between the inverter and motor does not exceed 50 m. (Smaller inverter capacity will be more impacted by wiring length) → Review layout so that wiring between the inverter and motor can be made shorter. Alternatively, shorten wiring lengths as much as possible. → Does not use automatic tuning, and does not use automatic torque boost (Set parameter E112*/E113*=0)
Er7 (Er7)		Tuning error	(4) Major discrepancy between the inverter rated capacity and the capacity of the connected motor	Check that the capacity of the connected motor is lower than three or more ranks of the inverter rated capacity, or higher than two or more ranks. → Review the inverter capacity. → Manually set the motor constant (parameter P06*,P07*,P08*). → Does not use automatic tuning, and does not use automatic torque boost (Set parameter E112*/E113*=0)
			(5) A special motor, such as a high-speed motor	→ Does not use automatic tuning, and does not use automatic torque boost (Set parameter E112*/E113*=0)
			(6) Tuning operation during which the motor is rotated with the brake applied (parameter P04*=2) performed	→ Tune the motor while stopped (parameter P04*=1). → Release the brake then tune the motor (parameter P04*=2).







Alarm code	Alarm sub-code	Name	Description	Check point and remedy reference
ErP (ErP)		RS-485 communications error (communications port 2)	(1) Different communications conditions with host equipment	Check that parameter (y11 to y19) data matches host equipment settings. → Correct the difference.
			(2) Communication time-out detection timer (parameter y18) is set, but communications are not performed at a defined cycle	Inspect the host controller side. → Change the host controller software settings, or disable the communication time-out detection timer (parameter {y08}/y18=0). Set (parameter y18 = 0) to disabled.
			(3) Error in host controller (software, settings, hardware, etc.)	Inspect the host controller (programmable controller, PC, etc.). → Eliminate the cause of the error in the host controller.
			(4) Error in the RS-485 converter (connection, settings, hardware, etc.)	Inspect the RS-485 converter (bad connection, etc.). → Change RS-485 converter settings, reconnect, or replace hardware (replace with recommended equipment).
			(5) Communications cable disconnection, bad connection	Check cable continuity and connections of the cable. → Replace the communications cable.
			(6) Strong noise received from surrounds	Check methods for measures against noise (grounding conditions, communications cable/main circuit wiring and installation). → Implement measures against noise. → Implement measures against noise for the host controller. → Replace the RS-485 converter with the recommended equipment (isolated type).
			(7) Termination resistance is not set correctly	Check if this inverter is the network terminal device. → Set the RS-485 communications terminating resistor selector switch (SW3/SW2) correctly. (If terminal, switch is ON)



Alarm code	Alarm sub-code	Name	Description	Check point and remedy reference
<b>Erd</b> (Erd)		Stall detection/ startup magnetic pole position detection failure	(1) Different motor characteristics	Check that parameter (F04,F05,P01,P02,P03,P60,P61,P62,P63,P64) data matches motor constants. → Perform auto tuning.
			(2) Magnetic pole position detection method is not appropriate	Check that the magnetic pole position detection method matches the motor type. → Match the magnetic pole position detection method (parameter P30) selection to the motor type.
			(3) Insufficient starting frequency (holding time) (parameter F24)	Check that, when setting the magnetic pole position detection method selection (parameter P30*) to 0 or 3, the starting frequency (holding time) (parameter F24) is set optimally. → Set a time that enables the motor to rotate one revolution or more. F24 ≥ P01/2/F23 (P01: pole, F23: starting frequency)
			(4) Insufficient starting torque	Check acceleration time (parameter F07, E10, E12, E14) and reference current at starting (parameter P74) data. → Set an acceleration time that matches the load. → Raise the reference current at starting.
			(5) Low braking load	Check reference current at starting (parameter P74*) data. → Lower the reference current at starting. When a motor is run on its own, such as during a test run, set to 80% or lower.
			(6) The connection between the inverter and the motor is missing phases	→ Ensure a correct connection between the inverter and motor.

Alarm code	Alarm sub-code	Name	Description	Check point and remedy reference
ErC (ErC)		Magnetic pole position detection error	(1) Inverter settings are not appropriate	<p>Check presence and model of the used motor, and of the speed/magnetic pole position sensor, and that 1st Drive Control Selection (F42)/Input Terminal [PIA][PIB] Pulse Input Format Selection (d14) and Input Terminal [PIA][PIB] Encoder Pulse Resolution (d15) are coordinated.</p> <p>→ Check the equipment configuration (model and specifications of motor, speed/magnetic pole position sensor), and set F42/d14/d15 correctly.</p> <p>Set the 1st PM Motor Starting Method (P30) to 0 or 3, and check if the 1st PM Motor Magnetic Pole position Offset (P95) is set to "999: offset has not been adjusted."</p> <p>→ Set P95 correctly. (Auto-tuning also is possible. Refer to <i>Offline Auto-tuning of Synchronous Motor (PM Motor)</i> on page 6-67.)</p>
			(2) Error with speed/magnetic pole position sensor connection	<p>Check for errors with speed/magnetic pole position sensor output wiring connection, and the phase sequence of AB or UVW phase.</p>
			(3) Motor rotation direction and sensor output do not match	<p>→ Correctly connect the feedback input terminal block board with the speed/magnetic pole position sensor.</p> <p>Check for bad connections in the motor wiring, and the phase sequence.</p> <p>→ Ensure a correct connection with the inverter and motor.</p>
			(4) Error in terminal block board connection	<p>Check if the terminal block board connector and inverter unit connector are correctly connected.</p> <p>→ Mount the terminal block board correctly in the inverter unit.</p>
			(5) Strong noise received from surrounds	<p>Check measures against noise (grounding conditions, signal wiring and communication cable/main circuit wiring and installation methods, etc.).</p> <p>→ Implement measures against noise.</p>

Alarm code	Alarm sub-code	Name	Description	Check point and remedy reference
ErE (ErE)		Inconsistent speed and excessive speed deviation	(1) Error in parameter settings	Check 1st Motor Pole Number (P01*). → Set P01* to match the motor used.
			(2) Excessive load	Measure the output current. → Reduce the load. Check if mechanical braking is occurring. → Eliminate any mechanical braking.
			(3) Speed does not increase because of current limiter operation	Check 1st Overload Protect Level (F44*) data. → Change F44 to appropriate values, or if current limiter operation is not necessary, change F43 data to 0 (Disable). Check that parameter (F04*, F05*, P01* to P12*) data to ensure that V/f settings are correct. → Coordinate V/f settings with motor ratings. → Change settings to match the motor used.
			(4) Parameter settings and the motor have different characteristics	Check that P01*, P02*, P03*, P06*, P07*, P08*, P09*, P10*, P12* match motor constants. → Perform auto tuning with P04*.
			(5) Erroneous wiring to motor	Check wiring to the motor. → Wire the inverter output wiring (U, V, W) to motor wiring (U, V, W) respectively.
			(6) Speed does not increase because of torque limit operation	Check Torque Limit 3 (E16) data. → Change Torque Limit 3 (E16) to appropriate value, or if torque limit operation is not necessary, set it to 300%.



Alarm code	Alarm sub-code	Name	Description	Check point and remedy reference
ErF (ErF)		Data save error in case of undervoltage	(1) During data save at power interruptions, the control power supply dropped suddenly as a result of rapid discharge of the Main Circuit DC Voltage, etc.	Check the power drop time at Main Circuit DC Voltage at power interruption. → Eliminate the cause of rapid discharge of the Main Circuit DC Voltage, etc. After pressing the  key to cancel the alarm, return the commands for frequency reference, PID command, and UP/DOWN signals set from the Digital Operator to their original settings, and restart operation.
			(2) Strong noise received from surrounds during data saving at power interruption.	Check methods for measures against noise (grounding conditions, control/main circuit wiring and installation). → Implement measures against noise. After pressing the  key to cancel the alarm, return the commands for frequency reference, PID command, and UP/DOWN signals set on the Digital Operator to their original settings, and restart operation.
			(3) Error occurred in control circuit	Check that erf occurs every time at power on. → Board (including CPU) error, so contact OMRON.
ErH (ErH)		Hardware error	(1) Error in combination of control PCB and power PCB	Replacement of control PCB or power PCB is necessary. → Please contact OMRON.
Ero (Ero)		Position control error	(1) Position control system insufficient gain (servo lock)	Readjust Servo Lock Gain (J97) and Speed Control 1 P Proportional Gain (d03).
Err (Err)		Mock alarm	(1) Press and hold the  key +  key for five seconds or longer.	→ Press the  key to reset.
			(2) Parameter H45 (Mock Alarm) set to 1.	
ErU (ErU)		Tool communication disconnection	(1) A disconnection occurred on the tool during a test run.	Check if the USB cable or a connector is disconnected.
			(2) A disconnection occurred on the tool during forced status changing of multifunction output.	→ Press the  key to reset.

Alarm code	Alarm sub-code	Name	Description	Check point and remedy reference
 (Lin)		Input phase loss	(1) Main power supply input terminal wiring disconnected	Measure the input voltage. → Repair or replace the main power supply input wiring or input equipment (molded case circuit breaker, magnetic contactor, etc.)
			(2) Loose main power supply input terminal connection	Check if main power supply input terminal screws are loose. → Tighten to the recommended tightening torque.
			(3) High phase imbalance in three-phase power supply	Measure the input voltage. → Install an AC reactor (ACR) to reduce the phase imbalance. → Increase the inverter capacity.
			(4) Frequent excessive load	Measure the ripple waveform of the Main Circuit DC Voltage. → If a ripple in the Main Circuit DC Voltage is high, increase the inverter capacity.
			(5) Three-phase power supply connected to a product with three-phase power supply specifications	Recheck the inverter model. → Reselect an inverter matching the power supply specifications.
 (LoK)		Password cancellation error	(1) User password 1 or 2 entered incorrectly more than a specified number of times	Cancel the alarm. → Turn OFF the inverter power supply, then turn ON the power supply again. Or 20 minutes elapse after the occurrence of the error.  If you have forgotten the password. → Set Data Initialization (H03) to 1 and execute parameter initialization.

Alarm code	Alarm sub-code	Name	Description	Check point and remedy reference
LU (LU)	1	Undervoltage	(1) Momentary power failure occurred	→ Cancel the alarm.
	3			→ To restart without an alarm, set the Power Interruption Restart Mode Selection (F14) data to 3, 4, or 5 depending on the type of load.
	2		(2) Short interval when cycling power (if F14=1)	Check if the power supply has been turned ON with the control power supply already ON (determine using Digital Operator display). → Turn the power supply ON again after the Digital Operator display has gone out.
			(3) The power supply voltage has not reached the inverter specification range (three-phase 200 V: 180 VDC/three-phase 400 V: 360 VDC/single-phase 200 V: 160 VDC)	Measure the input voltage. → Increase the power supply voltage to within the specified range.
			(4) Equipment damage or miswiring in power supply circuit	Measure the input voltage and identify the damaged equipment or miswiring. → Replace damaged equipment, or repair miswiring.
			(5) A large starting current flows to a different load connected to the same power supply, and the power supply voltage temporarily drops	Measure the input voltage, and check for voltage fluctuations. → Review the power supply system.
	(6) Insufficient capacity in the power supply transformer resulting in drop in power supply voltage due to inverter inrush current.	Check that an alarm occurs when the molded case circuit breaker, ground leakage circuit breaker (with overcurrent protection function), and magnetic contactor are on. → Review the power supply transformer capacity.		

Alarm code	Alarm sub-code	Name	Description	Check point and remedy reference
 (OCn)		Instantaneous overcurrent	(1) Short in inverter output	<p>Remove wiring from the inverter output terminal (U, V, W), and measure the resistance between motor wiring phases. Check for phases with very low resistance.</p> <p>→ Remove the shorted section (including replacement of wiring, relay terminals, and motors)</p> <p>If an overcurrent is displayed when run with wiring removed from the inverter output terminal (U, V, W).</p> <p>→ This indicates an inverter fault possibility. Please contact OMRON.</p>
			(2) Inverter output terminal has a ground fault	<p>Remove wiring from the inverter output terminal (U, V, W), and perform a megger test.</p> <p>→ Remove ground faults (including replacement of wiring, relay terminals, and motors).</p> <p>If an overcurrent is displayed when run with wiring removed from the inverter output terminal (U, V, W).</p> <p>→ This indicates an inverter fault possibility. Please contact OMRON.</p>
			(3) High load	<p>Measure current going in to the motor, establish current trends, and determine if this is larger than the load calculation values designed in to the system.</p> <p>→ If overload, either decrease the load or increase the inverter capacity.</p>
				<p>Check current trends, and check if there are rapid changes in current.</p> <p>→ If the current changes rapidly, either decrease the load or increase the inverter capacity.</p> <p>→ Enable instantaneous overcurrent limiting (H12=1).</p>
			(4) Thigh torque boost (If manual torque boost (E112*/E113*=0))	<p>Check if the current drops when 1st Manual Torque Boost Voltage (F09*) is reduced, or if there is a stall.</p> <p>→ If it is determined that there is no stall, lower F09*.</p>
	(5) Short acceleration/ deceleration time	<p>Recalculate torque required from the moment of inertia of the load and acceleration/ deceleration time, and determine if appropriate.</p> <p>→ Lengthen the acceleration/deceleration time (F07, F08, E10 to E15, H56).</p> <p>→ Enable 1st Overload Protect Function Selection (F43) and torque limit (F40, F41, E16, E17).</p> <p>→ Increase the inverter capacity.</p>		

Alarm code	Alarm sub-code	Name	Description	Check point and remedy reference
OCn (0Cn)		Instantaneous overcurrent	(6) Internal braking transistor short detection has operated	Check that the braking resistor connection terminal (P+, DB) is not shorted. Check if the connected braking resistor resistance value is very low. → Connect the appropriate braking resistor.
			(7) Malfunction because of noise	Check methods for measures against noise (grounding conditions, control/main circuit wiring and installation). → Implement measures against noise. For details, refer to 2-3-4 <i>Wiring for Main Circuit Terminals</i> on page 2-15. → Enable the retry function (H04). → Connect a surge absorber to coils, solenoids, etc. in magnetic contactors that are the cause of noise.
OH1 (0H1)		Cooling fin overheating	(1) The ambient temperature exceeds the inverter specification range	Measure the ambient temperature. → Reduce the ambient temperature such as by improving the air flow to the panel.
			(2) The airflow path is blocked	Check that there is sufficient installation space. → Re-install at a site where sufficient installation space can be ensured.
				Check for fin clogging. → Clean.
			(3) Reduced fan airflow because of the cooling fan service life or of damage	Check Cumulative Run Time of Cooling Fan (H43). → Replace the cooling fan.
Visually check that the cooling fan is operating correctly. → Replace the cooling fan.				
(4) High load	Measure the output current. → Set 28:OHF (Cooling fin overheat warning) to Output Terminal [DO1] Function Selection (E20), Output Terminal [DO2] Function Selection (E21) or Output Terminal [ROA, ROB] Function Selection (E27) whose load is to be reduced. Alternatively, reduce the load before an overload occurs using the Overload early warning 2 Level (OL2) (E34).			
	→ Reduce the Carrier Frequency (F26).			
	→ Enable Overload Prevention Control (H70)			

Alarm code	Alarm sub-code	Name	Description	Check point and remedy reference
0H2 (0H2)		External trip	(1) External equipment alarm function is operating	Inspect the operation of the external equipment. → Remove the cause of the alarm caused in the external equipment.
			(2) Miswiring or bad connection in external trip wiring	Check that wiring is correctly connected to the terminal for which "9: External trip (EXT)" is selected from E01 to E05, E98, E99. → Connect the external alarm wiring correctly.
			(3) Error in parameter settings	Check if "9: External trip (EXT)" is selected for an unused terminal from E01 to E05, E98, E99. → Change assignment.  Check that the "EXT" logic set in E01 to E05, E98, E99 and the external signal logic (positive/negative) match. → Set the logic correctly.
0H3 (0H3)	0	Inverter internal overheat	(1) The ambient temperature exceeds the inverter specification range	Measure the ambient temperature. → Reduce the inverter ambient temperature such as by improving the air flow to the panel.

Alarm code	Alarm sub-code	Name	Description	Check point and remedy reference
0H4 (0H4)		Motor protection (PTC thermistor)	(1) The motor ambient temperature exceeds the specification range	Measure the ambient temperature. → Reduce the ambient temperature.
			(2) Motor cooling system damaged	Check that the motor cooling system is operating correctly. → Replace or repair the motor cooling system.
			(3) High load	Measure the output current. → Reduce the load (use the Overload early warning 2 Level (OL2) (E34), and reduce the load before an overload occurs.) (During winter, the load may increase.) → Reduce the ambient temperature. → Increase the Carrier Frequency (F26).
			(4) Incorrect PTC thermistor operating level (H27*)	Check the PTC thermistor specifications, and recalculate the detection voltage. → Change the parameter data.
			(5) Inappropriate PTC thermistor settings	Check the Thermistor Function Selection (MOH) (H26*) and terminal AO function toggle switch (SW5). → Change the thermistor that uses H26* to suitable settings, and set SW5 to PO.
			(6) 1st Manual Torque Boost Voltage (F09*) too high	Check F09* data, and readjust so that this does not stall even if data is lowered. → Adjust F09*.
			(7) Error in V/f settings	Check that 1st Base Frequency (F04*) and 1st Rated Voltage at Base Frequency (F05*) match the rated nameplate value. → Match these to the rated nameplate value.
			(8) Error in parameter settings	While not using PTC thermistor, the Thermistor Function Selection (MOH) (H26*) is in an operation state. → Change Thermistor Function Selection (MOH) (H26*) to 0 (Disable).
0H6 (0H6)		Inrush current prevention resistor overheat	(1) The inverter power supply has been turned OFF and then ON frequently.	Reduce the frequency at which the power supply is turned OFF and then ON. → Turn OFF and then ON less than once every 30 minutes.
			(2) The inverter power supply has not been turned OFF and then ON frequently.	An error is generated each time the power supply is turned OFF and then ON. → The inrush current protection circuit is damaged. Request repair.

Alarm code	Alarm sub-code	Name	Description	Check point and remedy reference
OLn (OLn)		Motor overload 1 to 2	(1) The thermal characteristics of the electronics and the motor overload characteristics do not match	Check motor characteristics. → Review parameter (F10*, F12*) data. → Use an external thermal relay.
			(2) Inappropriate electronics thermal operating level	Recheck motor allowable continuous current. → Reconsider and change parameter (F11*) data.
			(3) Short acceleration/deceleration time	Recalculate acceleration/deceleration torque and acceleration/deceleration time required from the moment of inertia of the load and acceleration/deceleration time. → Lengthen the acceleration/deceleration time (F07, F08, E10 to E15, H56).
			(4) High load	Measure the output current. → Reduce the load (use the Overload early warning 2 Level (OL2) (E34), and reduce the load before an overload occurs.) (During winter, the load may increase.)
			(5) 1st Manual Torque Boost Voltage (F09*) too high	Check F09* data, and readjust so that this does not stall even if data is lowered. → Adjust F09*.



Alarm code	Alarm sub-code	Name	Description	Check point and remedy reference
0LU (OLU)		Inverter overload	(1) The ambient temperature exceeds the inverter specification range	Measure the ambient temperature. → Reduce the ambient temperature such as by improving the air flow to the panel.
			(2) 1st Manual Torque Boost Voltage (F09*) too high	Check 1st Manual Torque Boost Voltage (F09*) and readjust so that this does not stall even if data is lowered. → Adjust F09*.
			(3) Short acceleration/deceleration time	Recalculate acceleration/deceleration torque and acceleration/deceleration time required from the moment of inertia of the load and acceleration/deceleration time. → Lengthen the acceleration/deceleration time (F07, F08, E10 to E15, H56).
			(4) High load	Measure the output current. → Reduce the load (use the Overload early warning 2 Level (OL2) (E34), and reduce the load before an overload occurs.) (During winter, the load may increase.) → Decrease the Carrier Frequency (F26). → Enable Overload Prevention Control (H70)
			(5) The airflow path is blocked	Check that there is sufficient installation space. → Ensure sufficient installation space. Check for fin clogging. → Clean.
			(6) Reduced fan airflow because of the cooling fan service life or of damage	Check the cumulative run time of the cooling fan. (Refer to 7-8-13 <i>Cooling Fan Life Warning Signal (WAF)</i> on page 7-99.) → Replace the cooling fan. Visually check that the cooling fan is operating correctly. → Replace the cooling fan.
			(7) Long output wiring, with high leakage current	Measure the leakage current → Insert an output circuit filter (OFL).
0PL (OPL)		Output phase loss detection	(1) Disconnected invert output wiring	Measure the output current. → Replace the output wiring.
			(2) Motor windings broken	Measure the output current. → Replace the motor.
			(3) Loose inverter output terminal connection	Check if inverter output terminal screws are loose. → Tighten to the recommended tightening torque.

Alarm code	Alarm sub-code	Name	Description	Check point and remedy reference
05 (0S)		Excessive speed protection	(1) Error in parameter settings	<p>Check 1st Motor Pole Number (P01*).</p> <p>→ Set P01* to match the motor used.</p> <hr/> <p>Check 1st Maximum Output Frequency (F03*) settings.</p> <p>→ Set F03* to match the output frequency.</p> <hr/> <p>Check Speed Limit 1 in Forward (d32) and Speed Limit 2 in Reverse (d33) settings.</p> <p>→ Disable Speed Limit 1 in Forward (d32) and Speed Limit 2 in Reverse (d33).</p> <hr/> <p>Check Over Speed Detection Level (d35) settings.</p> <p>→ Set Over Speed Detection Level (d35) to 120%.</p>
			(2) Insufficient speed regulator gain	<p>Check that the speed does not overshoot during high-speed running.</p> <p>→ Increase the Speed Control 1 P Proportional Gain (d03*).</p> <p>(In some cases, a review of filters and integral time will be necessary.)</p>
			(3) Noise superimposed on the PG signal	<p>Check the PG signal input monitor, and check measures against noise (grounding conditions, signal wiring/main circuit wiring and installation methods, etc.).</p> <p>→ Implement measures against noise.</p>
			(4) Output frequency and motor rotation speed exceeded 599 Hz	<p>If using at near 590Hz, check that the acceleration time is not short, there is no load variation, and that the speed regulator Speed Control 1 P Proportional Gain (d03*) and Speed Control 1 I Integral Time (d04*) are appropriate.</p> <p>→ Decrease the run frequency.</p>
0Un (0Un)		Overvoltage	(1) The power supply voltage exceeds the inverter specification range (three-phase 200 V and single-phase 200 V: 420 VDC/three-phase 400 V: 840 VDC)	<p>Measure the input voltage.</p> <p>→ Decrease the power supply voltage to within the specified range.</p> <p>→ If the power supply voltage is within the specification range, this indicates an inverter fault. Please contact OMRON.</p>
			(2) Surge in the input power supply	<p>When a phase advance capacitor is turned ON/OFF or a thyristor converter operates on the same power supply system, a transient abnormal surge may occur in input voltage.</p> <p>→ Set a DC reactor.</p>

Alarm code	Alarm sub-code	Name	Description	Check point and remedy reference
0Un (0Un)		Overvoltage	(3) Short deceleration time for the moment of inertial of the load.	<p>Recalculate the deceleration torque from the moment of inertia of the load and the deceleration time.</p> <ul style="list-style-type: none"> <li>→ Lengthen the deceleration time (F08, E11, E13, E15, H56).</li> <li>→ Enable Anti-regenerative Control Function Selection (H69) or Over-Excitation Control Selection during Deceleration Function Selection (H71).</li> <li>→ Enable torque limit (F40, F41, E16, E17).</li> <li>→ Set 1st Rated Voltage at Base Frequency (F05*) to 0, and increase braking performance.</li> <li>→ Consider use of braking resistor.</li> </ul>
			(4) Short acceleration time	<p>Check if an overvoltage alarm occurs at the end of sudden acceleration.</p> <ul style="list-style-type: none"> <li>→ Lengthen the acceleration time (F07, E10, E12, E14).</li> <li>→ Use Acceleration/Deceleration Pattern Selection (H07).</li> <li>→ Consider use of braking resistor.</li> </ul>
			(5) High braking load	<p>Compare load braking torque and inverter braking torque.</p> <ul style="list-style-type: none"> <li>→ Set 1st Rated Voltage at Base Frequency (F05*) to 0, and increase braking performance.</li> <li>→ Consider use of braking resistor.</li> </ul>
			(6) Output has a ground fault	<p>If this operates correctly when run with wiring removed from the inverter output terminal (U, V, W).</p> <ul style="list-style-type: none"> <li>→ Check that the output wiring or the motor do not have a ground fault.</li> </ul> <p>If an overvoltage is displayed when run with wiring removed from the inverter output terminal (U, V, W).</p> <ul style="list-style-type: none"> <li>→ This indicates an inverter fault possibility. Please contact OMRON.</li> </ul>
		(7) Malfunction because of noise	<p>Check that the Main Circuit DC Voltage at the time of overvoltage is at or below the overvoltage level.</p> <ul style="list-style-type: none"> <li>→ Implement measures against noise.</li> <li>→ Enable Retry Count at Trip (H04).</li> <li>→ Connect a surge absorber to coils, solenoids, etc. in magnetic contactors that are the cause of noise.</li> </ul>	
PbF (PbF)		Charging circuit malfunction (1.5 kW min.)	(1) The charging circuit is damaged	<p>Repair of the inverter is required.</p> <ul style="list-style-type: none"> <li>→ Please contact OMRON.</li> </ul>









Alarm code	Alarm sub-code	Name	Description	Check point and remedy reference
P0 (PG)		PG disconnection	(1) Break in wiring between pulse generator and option	Check that the pulse generator is correctly connected, and that there is no break in wiring. → Check that the pulse generator is correctly connected, or tighten screws. → Check that the connecting sections are not caught. → Replace with wiring that is not broken.
			(2) Strong noise received from surrounds	Check measures against noise (grounding conditions, signal wiring and communication cable/main circuit wiring and installation methods, etc.). → Implement measures against noise. → Separate main circuit wiring and control circuit wiring as much as possible.
d0 (d0)		Excessive positioning deviation	(1) Encoder disconnection	Check that there are no breaks in encoder wiring.
			(2) Mismatch between the encoder rotation direction (wiring phase sequence) and motor rotation direction (inverter output phase sequence)	Connect so that all directions match, and review settings. Review d14 to d17 settings values.
			(3) Deviation over settings values are too low	Review d223, d224 settings values. If settings values are low, increase these.
			(4) Position control gain is too low	Review d203, d204 settings values. If settings values are low, increase these.
			(5) Speed control gain is too low.	Review d03(A45,b45,r45) settings values. If settings values are low, increase these.
			(6) Torque is limited	If a torque limit is operating, then position control and speed control will not operate correctly. Take the following measures so that the torque limit is not applied. • Reduce load • Review acceleration/deceleration time • To reduce load, review the speed reduction ratio, motor capacity, and other equipment configuration.



Parameters marked with \* are for 1st control only. When using 2nd control, refer to *2nd Control Function (SET)* on page 5-52 and replace these values.

## 9-1-3 Minor Fault Code List

Alarm code	Alarm subcode	Name	Description	Check point and remedy reference
<b>CnT</b> (CnT)		Equipment service life (number of startups)	(1) Equipment service life (number of startups)	Displayed when the motor number of startups reaches the number set in 1st Preset Startup Count for Motor Maintenance (H79). Additionally, the current number of startups can be confirmed in 1st Startup Count for Motor (H44), therefore before reset, set H44 data to 0000.
<b>LIF</b> (LiF)		Life prediction	(1) Life prediction	Any one of the main circuit capacitor used in the inverter, the capacitors on the printed circuit board, and the cooling fan has reached the end of its life. Referring to 7-8-10 <i>Capacitor Life Warning Signal (WAC)</i> on page 7-96, 7-8-13 <i>Cooling Fan Life Warning Signal (WAF)</i> on page 7-99 and 7-8-14 <i>Lifetime Alarm (LIFE)</i> on page 7-100, check the status of consumable parts.
<b>OH</b> (OH)		Cooling fin overheat prediction	(1) Cooling fin overheat prediction	Displayed as a prediction before the cooling fin overheat trip OH1 occurs. For measures, refer to "OH1 Heat sink overheat ( page 9-17)."
<b>OL</b> (OL)		Motor overload prediction	(1) Motor overload prediction	Displayed as a prediction prior to a motor overload 011 alarm occurring, and sets the current value at which the Overload early warning 2 Level (OL2) (E34) operates. Check that the actual current flowing in the motor is not higher than the value set in E34.
<b>Pid</b> (Pid)		PID warning output	(1) PID warning output	Displayed when a warning (warning from absolute value, warning from PID error) is output during PID operation. For details, refer to <i>PID Deviation Excessive (OD)</i> on page 7-133.
<b>rEF</b> (rEF)		Command loss	(1) Command loss	When the analog frequency setting (terminals AI1, AI2(AII), AI2(AIV)) command suddenly decreases to 10% or less, it is judged to be a wire break and ref is displayed. Check the wiring.
<b>rTE</b> (rTE)		Equipment service life (cumulative operation time of motor)	(1) Equipment service life (cumulative operation time of motor)	Displayed when the cumulative operation time of motor reaches the time set in parameter H78 (Maintenance interval). Cumulative motor run time can be checked in H94* (Cumulative operation time of motor). This can also be reset by setting the H94* value to 0.
<b>LoK</b> (LoK)		Password cancellation error	(1) User password 1 or 2 entered incorrectly 5 times.	Cancel the alarm. → Turn OFF the inverter power supply, then turn ON the power supply again. Or 20 minutes elapse.

## 9-1-4 Other Display List



Name	Description	Digital operator display
Disable selection display	Displayed when the operation selection of the control mode to handle data selected within Operator Display Selection during Run (E43) is disabled.	Lit or blinking 
No data	Displayed when the data assigned in the parameter and submenu does not exist.	
I/O all OFF display	Displayed when all points are OFF in the I/O check terminal I/O binary display.	
Communications not established display	Displayed when communications with the inverter have not been established, such as at power supply ON, etc.	
Measuring capacitor capacity	Displayed during measurement of capacitors at a primary voltage drop.	
RUN command display at insufficient voltage levels	Displayed when at or below the insufficient voltage level and there is a RUN command when monitoring inverter output results from amongst LED monitors.  Covered LED monitor items: Speed monitor, output current, consumption power, torque detection value, output voltage, motor output, load rate, PID output  Non-covered LED monitor items: PID process, PID feedback, analog monitor	
Data overflow display	Displayed when the display coefficient is set too high, when selecting rotation speed, load speed, and line speed in the LED monitor and run monitor, and the display speed is 100000 or higher (at display data overflow).	
Parameter disable selection display	Displayed when disable is selected while setting parameters.	
Password protection status display	Displays the password protection status by lighting or blinking the least significant digit dot during display of the main menu or lower level parameters.  Lit: Password protection enabled Blinking: Password is temporarily not protected Off: Password protection disabled	Least significant dot lit or blinking (Display example) 
STO state display	Displays the STO state when the functional safety STO input terminal is turned OFF when there is a RUN command in the operation mode.	
Run/operation complete display	Displayed at operation completion of timer operation or transport operation in the operation mode. Additionally, this is displayed at operation completion of auto-tuning.	
During jogging operation	Indicates that the inverter is in jogging operation status in the operation mode.	

Name	Description	Digital operator display
During DC output	<p>Indicates that DC output is in progress in the operation mode.</p> <p>DC output cause: DC braking, auxiliary excitation</p> <p>If this occurs at the same time as during jogging operation, this display has priority.</p>	
Favorite display	<p>Displays favorite registration status by lighting the most significant digit dot during display of the main menu parameters.</p> <p>Lit: Favorite registration complete</p> <p>Off: Favorite registration canceled</p>	<p>Most significant dot display (Display example)</p> 

## 9-2 Troubleshooting

If you feel that the inverter operation is strange or that the inverter does not operate as intended, use the following information as a reference, even if the inverter displays no alarm indication.

If the inverter trips with an alarm indication, refer to *9-1 Alarm Display and Remedies* on page 9-2.

Symptom	Possible cause	Remedy	Reference page	
The power supply is not turned on. (The POWER LED on the inverter is not lit.)	The short-circuit bar between the terminal +1 and P/+2 is removed, or no DC reactor is connected.	Install the short-circuit bar, or connect a DC reactor.	page 2-10	
	Input wiring is disconnected.	Check the input wiring.	page 2-45	
The RUN command is input, but the motor does not rotate.	1st RUN Command Selection (F02) is incorrect.	Set 1st RUN Command Selection (F02) correctly.	page 5-25	
	1st Frequency Reference Selection (F01) is incorrect.	Set 1st Frequency Reference Selection (F01) correctly according to the frequency reference input method, and specify the frequency.		
	There frequency is set to 0 Hz.	When the 1st Frequency Reference Selection (F01) is set to "1, 2, 3, 5: Analog voltage input," input the analog voltage or current signal corresponding to the frequency to the terminal AI1 or AI2. For details on switching between the analog voltage and current signals, refer to <i>5-5-1 Frequency Reference Selection</i> on page 5-27.		page 5-27
		When the 1st Frequency Reference Selection (F01) is set to "0: Digital Operator," set the frequency with the operator "  /  key." The set values are reflected in C99 (Digital Reference Frequency (multi-step speed reference 0)) / E109 (2nd Digital Reference Frequency (2nd multi-step speed reference 0)) in accordance with No. 1 control / No. 2 control.		
Input the frequency according to the 1st Frequency Reference Selection (F01). (The input frequency will be displayed in the frequency reference monitor (monitor mode: 3_02).)				
	For the multi-step speed operation, set the frequency to the multi-step speed reference 0 to 15 (C99, E109, C05 to C19).		page 5-57	



Symptom	Possible cause	Remedy	Reference page
The RUN command is input, but the motor does not rotate.	No multifunction input terminal is allocated for the RUN command.	To input the RUN command via a multifunction input terminal, set the used terminal to "98: FW (forward rotation)" or "99: RV (reverse rotation)." To input the RUN command via the 3-wire input function, set them to "98: FW," "6: STP" and "97: F/R."	page 5-55 page 5-56
	Multi-step speed settings "0: CF1" to "03: CF4" are set to the multifunction input terminal, and these are ON.	Disable the multi-step speed setting. (When this setting is enabled, multi-step speed operation is performed, so the motor does not rotate if the frequency values in the Multi-step Frequency Reference 1 to 15 (C05 to C19) are 0 (default).)	page 5-57
	Both the forward and reverse input terminals are ON.	To input the RUN command via the forward/reverse input terminal, turn ON either of them.	page 5-55
	The Reverse Rotation Prevention Function (H08) is set to limit the forward or reverse rotation.	Set Reverse Rotation Prevention Function (H08) correctly.	page 7-117
	The input terminal wiring or short-circuit bar connection for the RUN command is incorrect.	Wire correctly. (The multi-function input terminal status can be checked in the Input Terminal Monitor (W40)/Output Signal Monitor (W41).)	page 2-10 page 2-12 page 2-51
	The analog input or variable resistor wiring for the frequency reference is incorrect.	Wire correctly. <ul style="list-style-type: none"> <li>For the analog voltage or variable resistor input, measure the voltage between the terminals AI1 to AIC or AI2 to AIC with a tester etc. to check that the voltage is correct.</li> <li>For the analog current input, with the wires disconnected, measure the current flowing between the power supply and AI1 terminals with a tester etc. to check that the current is correct.</li> </ul>	page 2-10 page 7-35
	Although the inverter is operated via the digital operator, the multifunction input terminal is set to "162: F-TM (Forced terminal block)" and that terminal is ON.	Turn OFF the terminal to which the function is allocated.	page 7-75
	Although the inverter is operated via the control circuit terminal block, the multifunction input terminal is set to "35 OPE (Forced operator function)" and that terminal is ON.	Turn OFF the terminal to which the function is allocated.	page 7-75
An inverter trip occurred. (The ERR LED lights and the alarm code is displayed)	Press the  key to reset the trip and, after determining the cause and taking countermeasures based on the alarm code, restart the inverter.	page 5-49 page 9-2	

Symptom	Possible cause	Remedy	Reference page
The RUN command is input, but the motor does not rotate.	When the safety function selector switch (SW9) is OFF, either the multifunction input terminal SF1 or SF2 is OFF.	To use the safety function, turn ON both of the safety input terminals SF1 and SF2. To disable this function, set the safety function selector switch to ON.	page 7-69
	The multifunction input terminal is set to "8: RS (Reset)," "15: CS (Commercial switching)," "16: SW60 (Commercial switching)" or "7: FRS (Free-run stop)," and that terminal is ON.	Turn OFF the terminal to which the function is allocated.	page 7-60 page 5-49 page 7-141
	The multifunction input terminal is set to "38: ROK: (Permission of run command)" and that terminal is ON.	Turn ON the terminal to which the function is allocated.	page 7-117
	The wiring from the inverter to the motor, or the internal wiring of the motor, is disconnected.	Check the input wiring.	page 2-10 page 2-48
	The load is too heavy.	Reduce the load.	-
	The motor brake is applied.	Release the brake.	-
	There is a contact failure for the analog input or variable resistor.	Check the input wiring. <ul style="list-style-type: none"> <li>For the analog voltage or variable resistor input, measure the voltage between the terminals AI1 to AIC or AI2 to AIC with a tester etc. to check that the voltage is correct.</li> <li>For the analog current input, with the wires disconnected, measure the current flowing between the power supply and AI1 terminals with a tester etc. to check that the current is correct.</li> </ul>	page 2-10 page 7-35
	The overload limit or overcurrent suppression function is active.	Disable the function, or increase the level at which the function is activated.	page 7-82 page 7-87
	The 1st Maximum Output Frequency (F03) and 1st Frequency Upper Limit (F15)/2nd Frequency Upper Limit (E117) are set too low.	Change the set value.	page 5-19 page 5-32
The acceleration time is too long.	Decrease the acceleration time (F07/E10/E12/E14).	page 5-39	
The multifunction input terminal is set to "10: JOG: (Jogging)" and that terminal is ON.	Turn OFF the terminal to which the function is allocated.	page 5-60	

Symptom	Possible cause	Remedy	Reference page
The motor rotation speed does not increase.	Multi-step speed settings “0: CF1” to “3: CF4” are set to the multi-function input terminal, and these are ON.	Disable the multi-step speed setting. (When this setting is enabled, multi-step speed operation is performed, so the motor runs according to the frequency set in the Multi-step Frequency Reference 1 to 15 (C05 to C19).)	page 5-58
	The load is too heavy.	Reduce the load.	-
	The motor brake is applied.	Release the brake.	-
The frequency cannot be set at 1st Frequency Reference/1st Multi-step Frequency Reference 0 (C99)/2nd Frequency Reference/2nd Multi-step Frequency Reference 0 (E109) on the Digital Operator.	The 1st Frequency Reference Selection (F01) is set to other than digital operator.	Set the 1st Frequency Reference Selection (F01) to “0: (Digital Operator).”	page 5-27
	The multifunction input terminal is set to “162: F-TM (Forced terminal block)” and that terminal is ON.	Turn OFF the terminal to which the function is allocated.	page 7-75
The specified parameter does not appear.	The Operator Display Selection (E52) is set to “1: Parameter data check mode.”	Set Operator Display Selection (E52) to “2: Full menu mode.”	page 5-3
The parameter settings cannot be changed.	The inverter is in operation.	Stop the inverter. Then, set the parameters again after the motor stops with deceleration.	-
	Soft lock is enabled.	Disable the Operator Protection Function Selection (F00).	page 7-74
The motor rotates in reverse.	The phase sequence of wiring to the motor is incorrect. (The motor is not designed to rotate forward in the phase sequence: U/T1, V/T2, W/T3.)	Reverse the order of two wires connected to U/T1, V/T2, W/T3, or change the phase sequence to match that of the motor.	page 2-11
	The 3-wire input function is enabled, but the forward/reverse logic is incorrect.	Check the logic of the “97: F/R (3-wire forward/reverse)” allocated to a multifunction input terminal.	page 5-56
The motor rotates in reverse when the RUN key is pressed.	The operation direction based on the FW and RV terminals is incorrect.	Input the FW and RV terminals correctly.	page 5-25

Symptom	Possible cause	Remedy	Reference page
The inverter trips with an overcurrent protection during operation.	The acceleration time is set too short.	Increase the value set in the acceleration time (F07/E10/E12/E14).	page 5-39 page 5-43
		Use the acceleration/deceleration stop function to change the operation pattern to stop accelerating temporarily.	page 5-42
	The load is too heavy.	Reduce the load.	-
		Use the torque boost function to adjust the torque.	page 5-73
		With 1st Drive Control Selection (F42)/2nd Drive Control Selection (A14) to "0: IM V/f control," set "Free V/f voltage (E167/E169/E171/E173/E175/E177/E179)" or "5: (IM Vector control without speed sensor)" and "15: (PM Vector control without speed and pole position sensor)" and perform tuning.	page 5-10 page 6-16
	The 1st Overload Protect Function Selection (F43)/2nd Overload Protect Function Selection (E146) is set to "0: Disable (Current limiter does not work.)."	Enable the 1st Overload Protect Function Selection (F43)/2nd Overload Protect Function Selection (E146).	page 7-82
If an overcurrent trip occurs during operation although the overload limit function is enabled:			
	1st Overload Protect Level (F44)/2nd Overload Protect Level (E147) is too high.	Decrease the 1st Overload Protect Level (F44)/2nd Overload Protect Level (E147).	page 7-82
 key is disabled.	Anti-regenerative Control Function Selection (H69) is enabled.	Set Anti-regenerative Control Function Selection (H69) to "0: (Disable)," or adjust the operation level of the function.	page 7-85



Symptom	Possible cause	Remedy	Reference page
The motor or machine causes a loud noise.	The carrier frequency is too low.	Increase the Carrier Frequency (F26). However, this may increase noise or leakage current from the inverter. In addition, the output current must be derated depending on the model. For details, refer to <i>A-1 Derating Table</i> on page A-2.	page 7-113 page A-2
	The frequency of the motor in rotation resonates with the machine's natural frequency.	Change the frequency setting. If resonance occurs during acceleration/deceleration, use the Jump Frequency (C01 to C04) to avoid the resonance frequency.	page 7-116
	The motor is overexcited.	Set the 1st Base Frequency (F04)/2nd Base Frequency (A02), 1st Rated Voltage at Maximum Output Frequency (F06)/2nd Rated Voltage at Maximum Output Frequency (A04) according to the motor ratings. If this does not improve the condition, slightly lower the 1st Rated Voltage at Base Frequency (F05)/2nd Rated Voltage at Base Frequency (A03) value. Or set the 1st Drive Control Selection (F42)/2nd Drive Control Selection (A14) to "0: V/f control (No slip compensation)," or, if using "V/f control with speed sensor," use Non-linear V/f Frequency 1 (E166)/Non-linear V/f Voltage 7 (E179) and perform tuning.	page 5-10 page 5-19
The inverter trips with an overcurrent protection (OLU).	The thermistor trip is not set appropriately.	Disable Thermistor Function Selection (MOH) (H26). Alternatively, adjust 1st Thermistor Error Detection Level (MOH) (H27).	page 7-88
The inverter trips with an overvoltage protection (OU <sub>n</sub> ) during deceleration.	The set deceleration time is too short.	Increase the value set in the deceleration time (F08/E11/E13/E15).	page 5-39 page 5-43
	Anti-regenerative Control Function Selection (H69) is set to "0: Disable."	Enable Anti-regenerative Control Function Selection (H69). However, when this function is enabled, the actual deceleration time may be longer than the set value. For details, refer to <i>7-8-2 Anti-regenerative Control Function</i> on page 7-85.	page 7-85
	If an overvoltage trip occurs during deceleration although Anti-regenerative Control Function Selection (H69) is enabled:		
	The Frequency Rising Limit for Torque Limit (H76) value is inappropriate.	Change the set values. For details, refer to <i>7-8-2 Anti-regenerative Control Function</i> on page 7-85.	page 7-85
The inverter trips with a thermistor error (OH4).	24-VDC voltage is input to the PTC terminal.	Remove 24-VDC voltage from the PTC terminal.	page 7-88

Symptom	Possible cause	Remedy	Reference page
The output frequency is unstable.	The parameter settings are inappropriate.	Change the output frequency value slightly away from the power supply frequency.	page 5-27
		Change 1st Output Current Fluctuation Damping Gain (H80) and 2nd Output Current Fluctuation Damping Gain (A41).	page 7-144
	The load changes significantly.	Increase the motor/inverter capacity.	-
	The power supply voltage fluctuates.	Take measure to reduce the fluctuation.	-
The torque is insufficient.	The parameter settings are inappropriate. (During acceleration/constant speed)	Increase 1st Manual Torque Boost Voltage (F09)/2nd Manual Torque Boost Voltage (A05).	page 5-73
		Set the 1st Torque Boost Function Selection (E112) and 2nd Torque Boost Function Selection (E113) to "1: Automatic torque boost."	page 5-73
		Decrease the Carrier Frequency (F26).	page 7-113
		Set the 1st Drive Control Selection (F42)/2nd Drive Control Selection (A14) to "5: IM Vector control without speed sensor."	page 6-16
	The parameter settings are inappropriate. (During deceleration)	Increase the value set in the deceleration time (F08/E11/E13/E15).	page 5-39
		Set 1st AVR Function Selection (E122)/2nd AVR Function Selection (E123) to OFF.	page 7-121
		Use braking resistors or regenerative braking units.	-
Operator communications error (Er2) occurred.	Broken wiring between the operator and the inverter unit.	Check the connection between the digital operator and the inverter unit.	-
The operation/setting via Modbus communication is not possible.	1st RUN Command Selection (F02)/2nd RUN Command Selection (E102) are incorrect.	Set 1st RUN Command Selection (F02)/2nd RUN Command Selection (E102) to "4. RS-485 communication (terminal block)."	page 5-25
	1st Frequency Reference Selection (F01)/2nd Frequency Reference Selection (C30) are incorrect.	Set 1st Frequency Reference Selection (F01)/2nd Frequency Reference Selection (C30) to "14. RS-485 communication (terminal block)."	page 5-27
	The communications speed setting is incorrect.	Set a correct communications speed in the RS-485 Communication Baud Rate (y14).	page 8-5
	The unit number setting is incorrect or overlaps.	Set a correct station number in the RS-485 Communication Station No. Selection (y11).	page 8-5
	The communications parity setting is incorrect.	Set a correct parity type in the RS-485 Communication Parity Bit Selection (y16).	page 8-5
	The wiring is incorrect.	Connect the wiring correctly to the terminal SP/SN on the control circuit terminal block.	page 8-4
	The address is incorrect.	<ul style="list-style-type: none"> <li>Check that the coil or register address setting is correct, which is 1 less than the coil or register No.</li> <li>If the Modbus mapping function is in use, check if the function settings are correct and, if necessary, make corrections.</li> </ul>	page 8-11 page 8-23

Symptom	Possible cause	Remedy	Reference page
Operating the inverter activates the earth leakage breaker.	The leakage current from the inverter is too large.	Decrease the Carrier Frequency (F26) value.	page 7-113
		Increase the sensitivity current of the earth leakage breaker. Or, replace the earth leakage breaker with one with a higher sensitivity current.	page 2-42
The DC injection braking function does not work.	The DC injection braking power is not set.	Set 1st DC Injection Braking Level (F21)/2nd DC Injection Braking Level (A10).	page 7-63
	The DC injection braking time is not set.	Set the 1st DC Injection Braking Time (F22)/2nd DC Injection Braking Time (A11).	page 7-63
The inverter trips with an undervoltage (LU).	The voltage dropped because the power supply capacity is insufficient.	Increase the power supply capacity.	-
Noise enters in the TV or radio located near the inverter.	The TV or radio is affected by the radiated noise from inverter.	Move the TV or radio as far away as possible from the inverter.	-
An option error (Er5) occurred.	The inverter received an error detected in the option unit.	Refer to the manual for the option unit.	-
	Inverter fault: The option connector does not work normally.	The connector may be faulty if the problem persists even after taking a remedy on the option unit side. If the problem persists even after checking the option connector for loose fitting and dirt on the contacts, replace the inverter.	-
An option communications error (Er5) occurred.	The inverter stops communicating with the option unit after recognizing it. The option unit is not mounted securely.	Check the option connector for loose fitting and dirt on terminal contacts. Check that the terminal block cover of the inverter is fit securely on the inverter.	-
	The Modbus mapping endian function setting is inappropriate.	Set Modbus Mapping Endian Selection (H396) to "00: (Big endian)."	page 8-23
Sysmac Studio cannot make an online connection.	The USB cable is not connected correctly.	Fully insert the USB cable into both the PC and controller.	-
	Sysmac Studio "Communications Settings" > "Communications Method" is not set to "USB-Direct Connection."	Set Sysmac Studio "Communications Settings" > "Communications Method" to "USB-Direct Connection."	-
	The USB driver is not correctly installed.	Install the USB driver. For details of USB driver installation methods, refer to the appendix of <i>Sysmac Studio Version 1 Operation Manual (SBCA-470)</i> .	-
The brake control function causes an overload protection alarm (OLU).	The inverter is in operation with the brake force.	Turn OFF the RUN command to the inverter in the brake force state. Even under DC injection braking, an overload protection alarm may occur.	page 6-72
	With at or lower than the Brake Control Brake-release Frequency (J69) set frequency, the brake does not release.	Set the frequency to a value exceeding the Brake Control Brake-release Frequency (J69) value.	page 6-72

Symptom	Possible cause	Remedy	Reference page
Brake transistor error (dbA) occurred.	The brake transistor is damaged.	Replace the inverter.	-
Brake error (Er6) occurred.	The output current does not reach the set brake release current value.	Increase the Brake Control Brake-release Timer (J70) or decrease the Brake Control Brake-release Current (J68).	page 6-72
	The brake confirmation signal is not input.	<ul style="list-style-type: none"> <li>Correct the wiring for the brake confirmation signal (57: BRK). If not used, deallocate the brake confirmation function from the multi-function input setting.</li> <li>Review the operation sequence so that the brake confirmation signal (57: BRK) is input after the brake is released.</li> <li>Replace the brake if it is faulty.</li> </ul>	page 6-72
	Brake confirmation signal is not input within the time set in Brake Error Detection Time (H180).	Adjust the Brake Error Detection Time (H180).	page 6-72
The brake control function causes the load to fall.	The set brake release current is insufficient.	Increase the Brake Control Brake-release Current (J68) value.	page 6-72
	The frequency setting for releasing/forcing the brake is too low.	Increase the Brake Control Brake-release Frequency (J69), Brake Force Frequency (J71), or Brake Control Brake-applied Frequency (J71) setting values.	page 6-72
The PM motor rotates during startup.	The magnetic pole position of the motor during startup is incorrect.	Set the 1st PM Motor Starting Method (P30) to "1: IPM (Embedded magnet motor method 1)," and reduce initial rotation at startup. If 0 or 3 are used in P30, reduce 1st PM Motor Reference Current at Starting (P74) to make reverse rotation more difficult.	page 6-22
	The PM motor stalls.	Increase the 1st PM Motor Reference Current at Starting (P74) value. Or perform adjustments according to <i>6-4-4 Adjustment of PM Motor Mode Settings</i> on page 6-22.	page 6-22
	The load is too heavy.	Reduce the load. Or, increase the acceleration/deceleration time.	-
Underbar display 	(1) The Main Circuit DC Voltage is dropped	<ul style="list-style-type: none"> <li>Connect a power supply with voltage specifications that match the input voltage.</li> </ul>	-
	(2) Only control power supply auxiliary input on, without main power supply.	<ul style="list-style-type: none"> <li>Turn the power supply ON.</li> </ul>	-
		<ul style="list-style-type: none"> <li>Install a shorting bar or DC reactor between terminal P1 and P(+), or tighten screws.</li> </ul>	page 2-11
(3) Main power supply input terminal wiring disconnected	<ul style="list-style-type: none"> <li>Repair or replace the main power supply input wiring or input equipment (molded case circuit breaker, magnetic contactor, etc.)</li> </ul>	page 2-15	

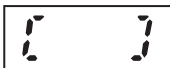

Symptom	Possible cause	Remedy	Reference page
Center bar display 	(1) With PID control not operating (J01 = 0), Operator Display Selection during Run (E43) is set to 10 or 12	<ul style="list-style-type: none"> <li>Set E43 to other than 10 or 12.</li> </ul>	page 7-76
	While PID control is operating (J01 = 1, 2, 3), and "PID process command" or "PID feedback value" set to display on the LED monitor using the  key, PID control has been set to disable (J01 = 0).	<ul style="list-style-type: none"> <li>Turn J01 to 1, 2, or 3.</li> </ul>	page 7-123
	(2) Operator connection error	<ul style="list-style-type: none"> <li>Replace the remote operation extension cable.</li> </ul>	-
Parentheses display 	(1) Displayed data is an overflow	<ul style="list-style-type: none"> <li>Review E50 data.</li> </ul>	page 7-76
The parameter settings cannot be changed (changed from link function)	(1) Attempted to change a parameter that cannot be changed during operation	<ul style="list-style-type: none"> <li>Stop operation and then change the parameter.</li> </ul>	-
	(2) Parameter F02 data cannot be changed	<ul style="list-style-type: none"> <li>Turn both terminal signals "FW" and "RV" OFF.</li> </ul>	page 5-55
Underbar and En display	(1) SF1 and SF2 terminals are OFF	<ul style="list-style-type: none"> <li>Turn SF1 and SF2 ON.</li> </ul>	page 7-69
		<ul style="list-style-type: none"> <li>When FW/RV signals are ON, turn the FW/RV signals OFF.</li> </ul>	page 5-55



# 10

## Maintenance and Inspection

This section describes the daily maintenance and periodical inspection items.

---

<b>10-1</b>	<b>Maintenance and Inspection .....</b>	<b>10-2</b>
10-1-1	Daily Inspection .....	10-2
10-1-2	Cleaning .....	10-2
10-1-3	Periodic Inspection .....	10-2
10-1-4	Daily/Periodic Inspection Items .....	10-3
10-1-5	Megger Test.....	10-6
10-1-6	Withstand Voltage Test.....	10-7
10-1-7	I/O Voltage/Current/Electric Power Measurement Method.....	10-7

# 10-1 Maintenance and Inspection

## 10-1-1 Daily Inspection

Check the following during operation.

- The motor operates according to the settings.
- There are no faults in the installation environment.
- There are no faults in the cooling system.
- There is no abnormal vibration or sound.
- There is no abnormal overheat or discoloration.
- There is no abnormal odor.
- There is no alarm display.

Check the input voltage of the inverter during operation by using a tester or other measuring equipment.

- There is no frequent power supply voltage fluctuation.
- The line voltage is balanced.

## 10-1-2 Cleaning

Always keep the inverter clean.

Lightly wipe the exterior surfaces of the inverter with a soft cloth moistened with a neutral detergent to remove dirt.

Do not use solutions such as acetone, benzene, toluene, or alcohol for cleaning. Doing so may cause the inverter surfaces to dissolve or its coating to come off.

In particular, do not use any detergent or alcohol to clean the digital operator display.

## 10-1-3 Periodic Inspection

Check the parts that must be checked with the operation stopped, as well as those that require periodic inspection.

Even if the power supply is turned OFF, it takes time for the smoothing capacitor of the main circuit DC section to discharge. Since this can be dangerous, use a tester or something similar to confirm that the Main Circuit DC Voltage has dropped down to a safe value (25 VDC or below), and then perform inspection.

- There are no faults in the cooling system.  
→Clean the air filter etc.
- Check for loose screws, and retighten.  
→The screws, bolts and other tightened parts may become loose due to vibration, temperature change, or other influences. Check these parts carefully and retighten them if necessary.
- Check for corrosion or damage to conductors and insulators.
- Measure the insulation resistance.
- Check the cooling fan, smoothing capacitor and relay.

**10-1-4 Daily/Periodic Inspection Items**

Inspection category	Inspection item	Inspection point	Inspection frequency			Inspection method	Criteria	Meter
			Daily	Periodic				
				1 year	2 years			
General	Ambient environment	Check ambient temperature, humidity and surrounding atmosphere (presence of dust, gas, oil mist, water droplets, etc.).	Required			Refer to 2-1 <i>Installation</i> on page 2-2.	Ambient temperature: -10 to 50°C, no freezing Operating humidity: 95% max., no condensation	Thermometer Hygrometer Recorder
	Entire system	There is no abnormal vibration or sound.	Required			Perform visual and acoustic inspection.	No faults	
	Power supply voltage	Check main circuit voltage.	Required			Measure line voltage between inverter main circuit terminals L1/R, L2/S and L3/T.	Within allowable AC voltage fluctuation range	Tester, digital multimeter
	Structural components such as the casing or cover	Check for deformation or damage.	Required			Perform visual inspection.	No faults	
		No deposition of dirt or dust	Required			Perform visual inspection.	No faults	

Inspection category	Inspection item	Inspection point	Inspection frequency			Inspection method	Criteria	Meter
			Daily	Periodic				
				1 year	2 years			
Main circuit	General	Perform megger check (Between main circuit terminals and ground terminal).		Required		Disconnect I/O wires from the inverter main circuit terminal block and remove the control terminal block PCB. Then, after removing the short-circuit bar for switching the inverter built-in filter function, measure using a megger the resistance between the ground terminal and the short-circuited terminals L1/R, L2/S, L3/T, U, V, W, P(+), P1, N(-) and DB.	5 MΩ min.	500-VDC class megger
		Check for loose bolts and screws.		Required		Retighten loose bolts and screws.	No faults	
		Check each part for traces of overheating.		Required		Perform visual inspection.	No faults	
	Conductors/wires	Check for distorted conductors.		Required		Perform visual inspection.	No faults	
		Check for broken cable sheaths.		Required				
	Terminal Blocks	Check for damage.		Required		Perform visual inspection.	No faults	
	Smoothing capacitor*1	Check that there is no liquid leakage.	Required			Perform visual inspection.	No faults	Capacity meter
		Check that the safety valve does not come out and that there is no bulge.	Required					
	Relay	Check for chattering sound during operation.		Required		Perform acoustic inspection.	No faults	
		Check for rough contact surface.		Required		Perform visual inspection.	No faults	

Inspection category	Inspection item	Inspection point	Inspection frequency			Inspection method	Criteria	Meter
			Daily	Periodic				
				1 year	2 years			
Control circuit, protection circuit	Operation check	Check output voltage balance between phases during stand-alone inverter operation.		Required		Measure the line voltage between the inverter main circuit terminals U, V and W.	Phase-to-phase voltage balance 200-V class: 4 V max. 400-V class: 8 V max.	Digital multimeter Rectifier Voltmeter
		Check that there is no error in protection and display circuits through sequence protection function test.		Required		Short-circuit or open the inverter protection circuit output under simulated conditions.	Error is found in the sequence.	
Cooling system	Cooling fan	There is no abnormal vibration or sound.	Required			Rotate the fan manually with the power off.	Smooth rotation, no faults*2	
		Check for loose connections.		Required		Perform visual inspection.		
	Cooling fin	Check for clogging.		Required		Perform visual inspection.	No clogging.	
Display	Display	Check that the LED indicators are lit properly.	Required			Perform visual inspection.	The LED indicators are lit.	
		Perform cleaning.		Required		Clean with rags.		
	Meter	Check indicated value.	Required			Check the indicated values on panel meters.	Specified value, control value	

Inspection category	Inspection item	Inspection point	Inspection frequency			Inspection method	Criteria	Meter
			Daily	Periodic				
				1 year	2 years			
Motor	General	There is no abnormal vibration or sound.	Required			Perform acoustic, sensory and visual inspection.	No faults	
		There is no abnormal odor.	Required			Check for abnormal odor due to overheating, damage, etc.	No faults	
	Isolation resistance	Perform megger check (between motor terminals and ground terminal).			Required	Disconnect wires from the inverter main circuit terminals U, V, W and short-circuit the three-phase motor wires. Then, use a megger to measure the resistance between each motor wire and the ground terminal.	5 MΩ min.	500-VDC class megger

- \*1. The capacitor service life is influenced by the ambient temperature. For inverter replacement guidelines, refer to *A-2 Smoothing Capacitor Life Curve* on page A-6.
- \*2. The life of the cooling fan depends on environmental conditions, such as the ambient temperature and/or dust. Check the operating conditions in daily inspection.

### 10-1-5 Megger Test

Before performing a megger test on external circuits, be sure to disconnect all the terminals of the inverter and not to apply the test voltage to the inverter. Use a 500 VDC megger for a megger test. For a megger test on the inverter main circuit, short-circuit the terminals L1/R, L2/S, L3/T, U, V, W, DB, P1, P(+) and N(-) with wires, as shown below.

Because the insulation resistance rating of the single inverter unit is 5 MΩ or higher, it is normal if the resistance is 5 MΩ or higher.

- For the inverter, do not perform a megger test on the control circuit. Perform it only on the main circuit.
- Use a tester (in a high resistance range) for a power-on test on the control circuit. Do not use a megger or buzzer.



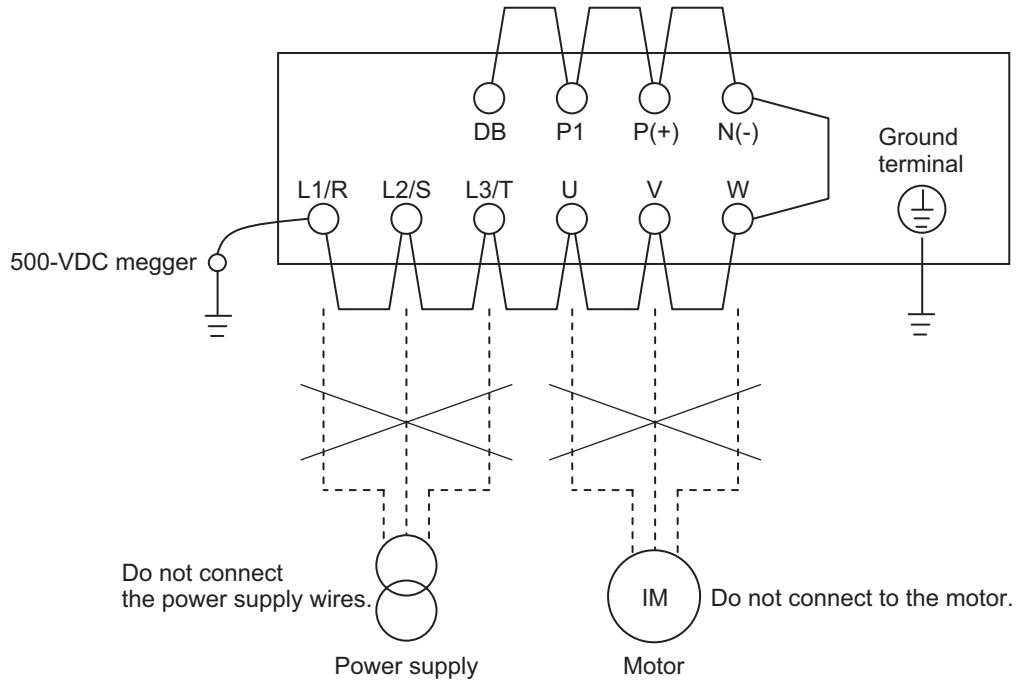

### 10-1-6 Withstand Voltage Test

Do not conduct a withstand voltage test on any part of the inverter.



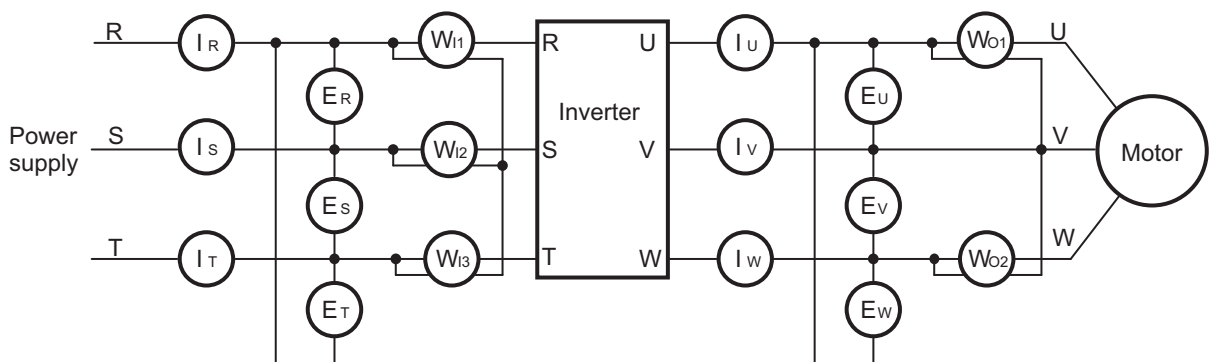

Doing this test is dangerous because it may cause damage to or deterioration of the parts inside the inverter.

### 10-1-7 I/O Voltage/Current/Electric Power Measurement Method

Measuring instruments commonly used for input/output voltage, current, or electric power measurement are shown below.



Measurement item	Measurement point	Measuring instrument	Remarks	Measurement value reference
Power supply voltage $E_{IN}$	Between L1/R and L2/S ( $E_R$ ) Between L2/S and L3/T ( $E_S$ ) Between L3/T and L1/R ( $E_T$ )	 Moving-iron voltmeter or rectifier type voltmeter	All effective values	200-V class: 200 to 240 V, 50/60 Hz 400-V class: 380 to 480 V, 50/60 Hz

Measurement item	Measurement point	Measuring instrument	Remarks	Measurement value reference
Power supply current $I_{IN}$	Current in L1/R, L2/S, L3/T ( $I_R$ ), ( $I_S$ ), ( $I_T$ )	 Moving iron ammeter	All effective values	When input current is not balanced: $I_{IN} = (I_R + I_S + I_T) / 3$
Input electric power $W_{IN}$	Between L1/R and L2/S ( $W_{I1}$ ) Between L2/S and L3/T ( $W_{I2}$ ) Between L3/T and L1/R ( $W_{I3}$ )	 Electrodynamic wattmeter	All effective values	Three-wattmeter method $(W_{I1}) + (W_{I2}) + (W_{I3})$
Input power factor $Pf_{IN}$	Calculate this from the measured values of power supply voltage $E_{IN}$ , power supply current $I_{IN}$ , and input electric power $W_{IN}$ . $Pf_{IN} = \frac{W_{IN}}{\sqrt{3} \cdot E_{IN} \cdot I_{IN}} \times 100 [\%]$			-
Output voltage $E_{OUT}$	Between U and V ( $E_U$ ) Between V and W ( $E_V$ ) Between W and U ( $E_W$ )	 Refer to the figure on the next page, or rectifier type voltmeter.	Effective value of fundamental wave	-
Output current $I_{OUT}$	Current of U, V and W ( $I_U$ ), ( $I_V$ ), ( $I_W$ )	 Moving iron ammeter	All effective values	-
Output power $W_{OUT}$	Between U and V ( $W_{O1}$ ) Between V and W ( $W_{O2}$ )	 Electrodynamic wattmeter	All effective values	Two-wattmeter method (or three-wattmeter method) ( $W_{O1}$ ) + ( $W_{O2}$ )
Output power factor $Pf_{OUT}$	Calculate this from the measured values of output voltage $E_{OUT}$ , output current $I_{OUT}$ , and output electric power $W_{OUT}$ . $Pf_{OUT} = \frac{W_{OUT}}{\sqrt{3} \cdot E_{OUT} \cdot I_{OUT}} \times 100 [\%]$			-

**Note 1.** For the output voltage, use a measuring instrument that shows effective values of fundamental wave.

For the current and the electric power, use a measuring instrument that shows all effective values.

**Note 2.** The output waveform of the inverter has a margin of error, especially at low frequencies, because it was generated under PWM control. Note that many general-purpose testers may not be usable due to noise.

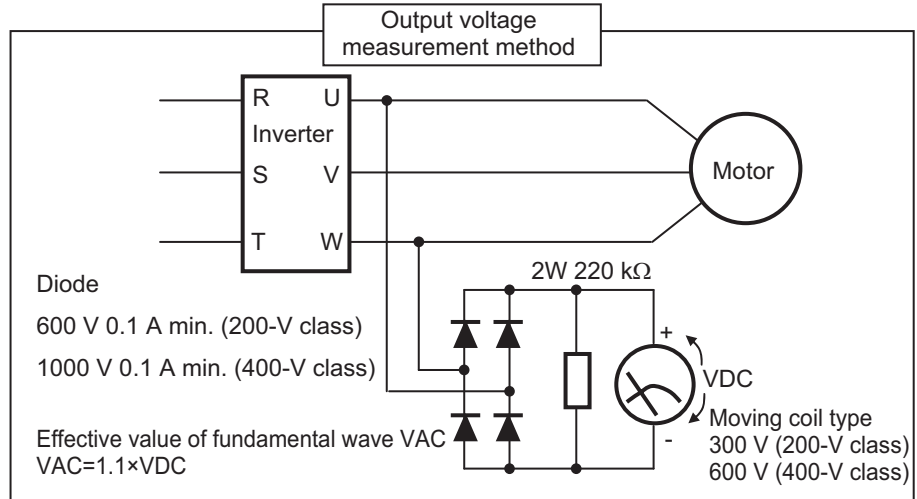





# Appendix

This section provides information on derating, capacitor life curve and inverter selection.

---

<b>A-1</b>	<b>Derating Table.....</b>	<b>A-2</b>
<b>A-2</b>	<b>Smoothing Capacitor Life Curve .....</b>	<b>A-6</b>
<b>A-3</b>	<b>Life Alarm Output .....</b>	<b>A-9</b>
<b>A-4</b>	<b>Overview of Inverter Selection.....</b>	<b>A-10</b>
A-4-1	Motor Capacity Selection .....	A-10
A-4-2	Inverter Capacity Selection .....	A-13
A-4-3	Overview of Braking Resistor Selection .....	A-14

# A-1 Derating Table

If you intend to use the inverter models with HND/HD/ND modes at the temperature of 40°C or higher, derating is required. Refer to the following output current derating depending on ambient temperature.

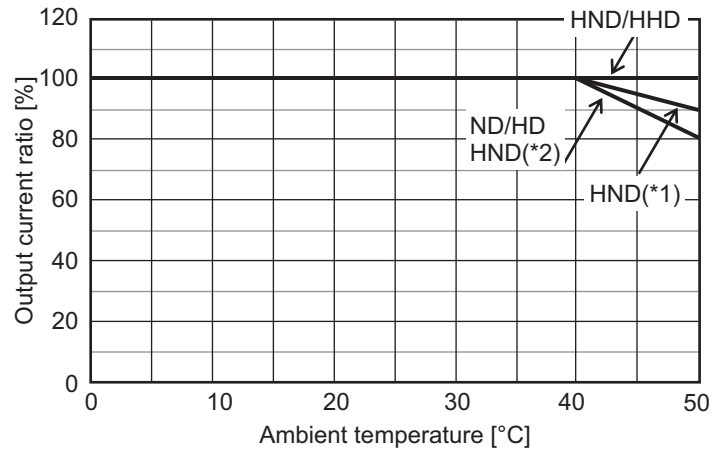

\*1. If using the 3G3M1-A2022/A2037/A4022/A4040 at 50°C, refer to the following *When Changing the Carrier Frequency for Use* on page A-2.

\*2. If using the 3G3M1-A4022/AB004/AB007/AB015/AB022 at 50°C, refer to the following *When Changing the Carrier Frequency for Use* on page A-2.

## When Changing the Carrier Frequency for Use

Refer to the following for derating output current when the carrier frequency is changed from the factory default. However, when using it side-by-side, the following derating is used in an ambient temperature of 40°C for HHD/HND and in an ambient temperature of 30°C for HD/ND.

### ● 3G3M1-A2001/A2002/A2004/A2007/A2015/A2022/A2037

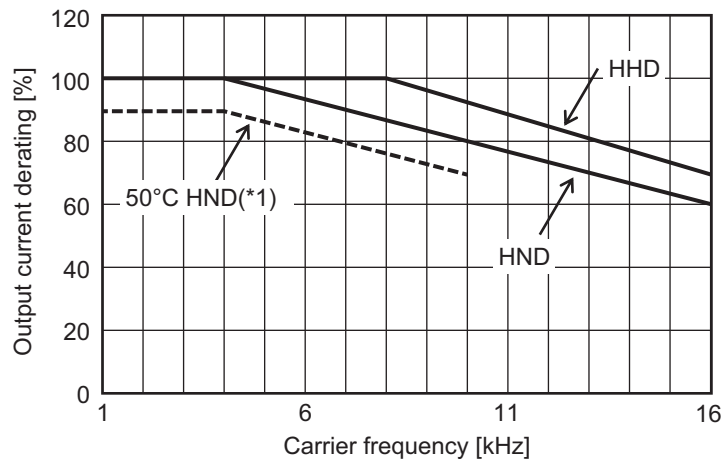

\*1. When using 3G3M1-A2022/A2037 at 50°C.

● 3G3M1-A2055/A2075/A2110/A2150/A2185

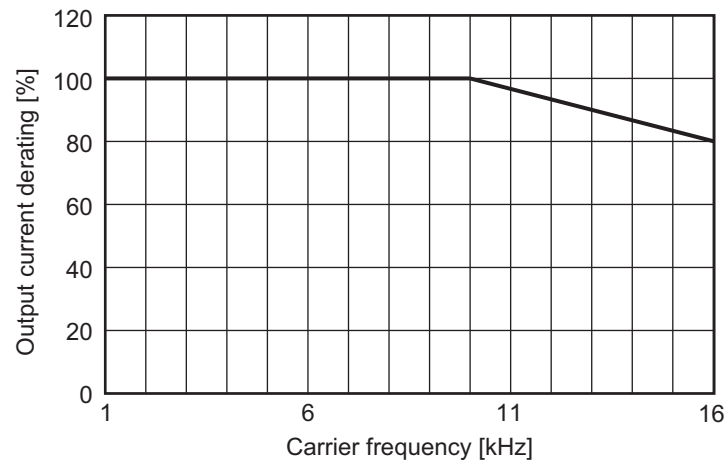

● 3G3M1-A4004/A4007/A4015/A4030/A4040/AB037

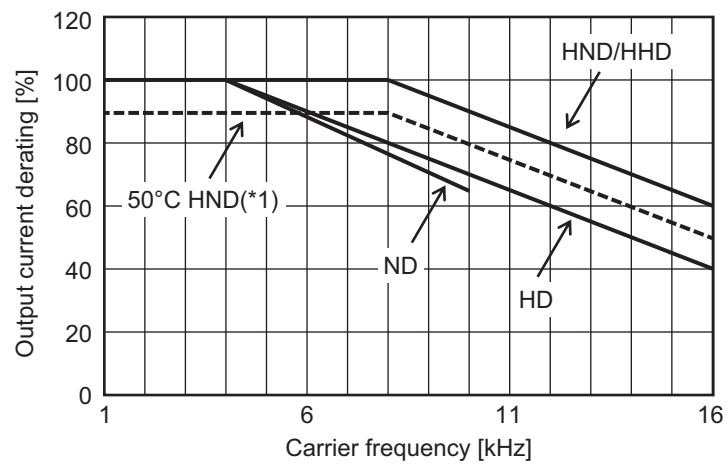

\*1. When using 3G3M1-A4040 at 50°C.

● 3G3M1-A4055/A4075/A4110/A4150/A4185

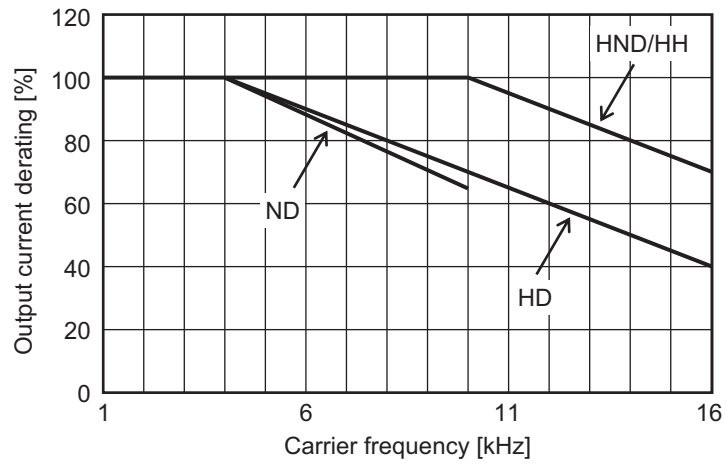

● 3G3M1-A4220

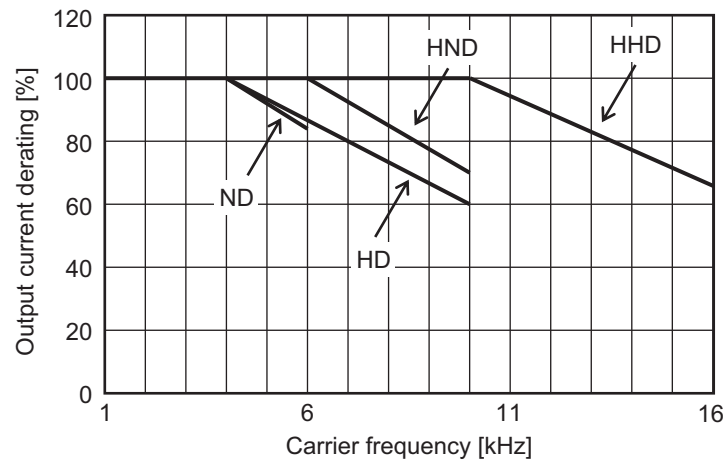



● 3G3M1-A4022

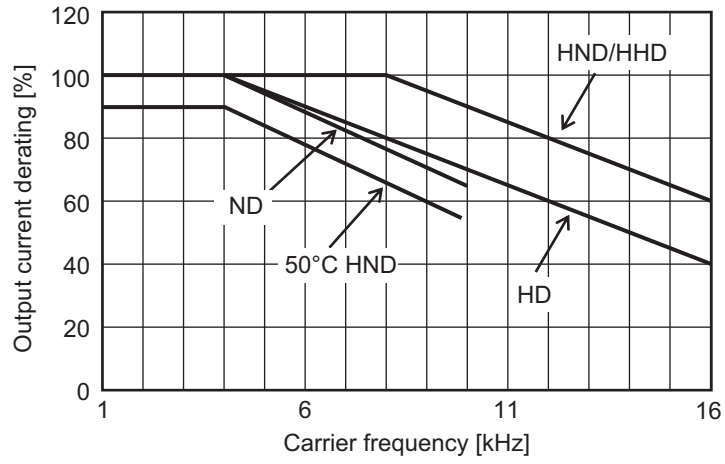

● 3G3M1-AB001/AB002/AB004/AB007/AB015/AB022

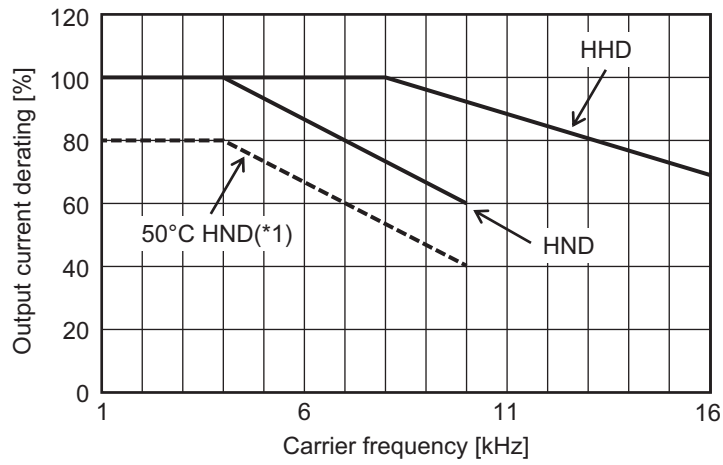

\*1. When using 3G3M1-AB004/AB007/AB015/AB022 at 50°C.

# A-2 Smoothing Capacitor Life Curve

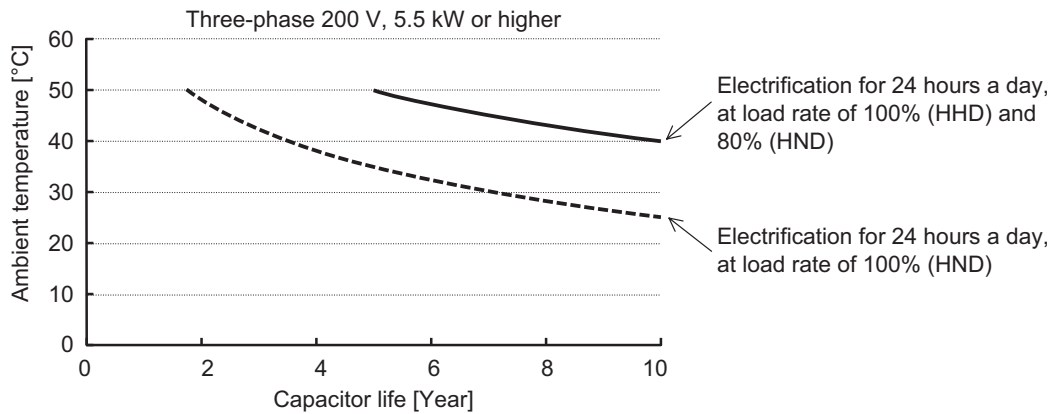
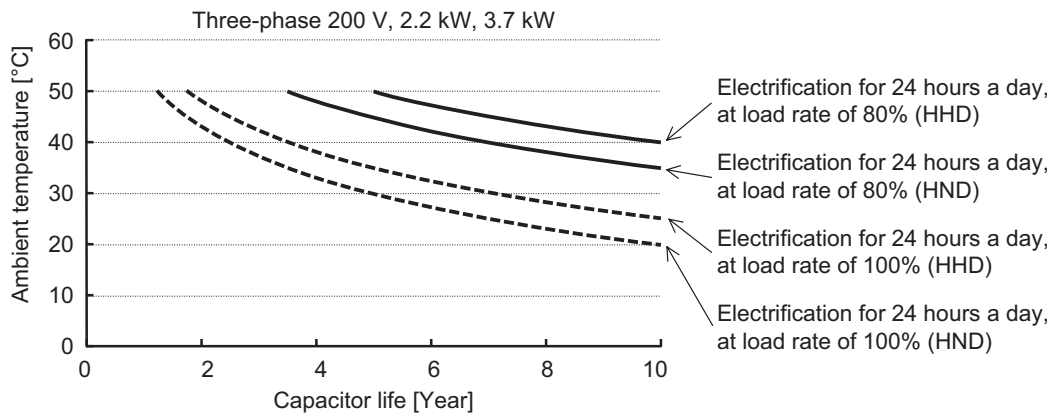
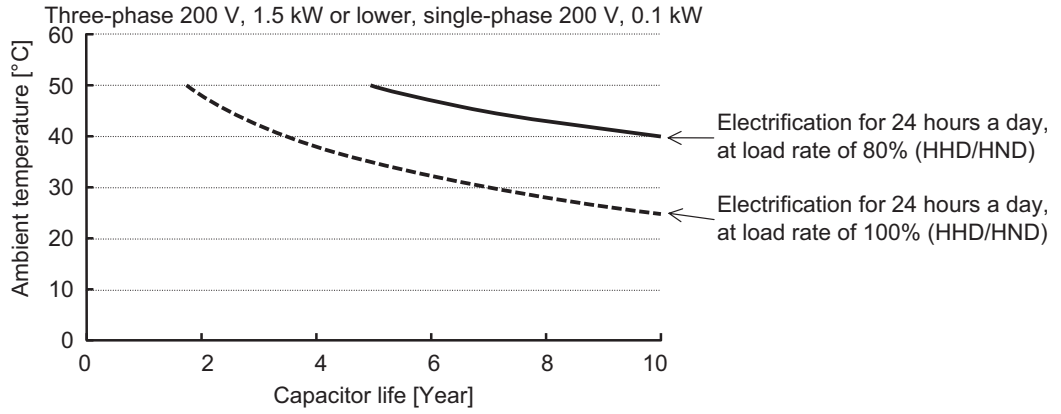

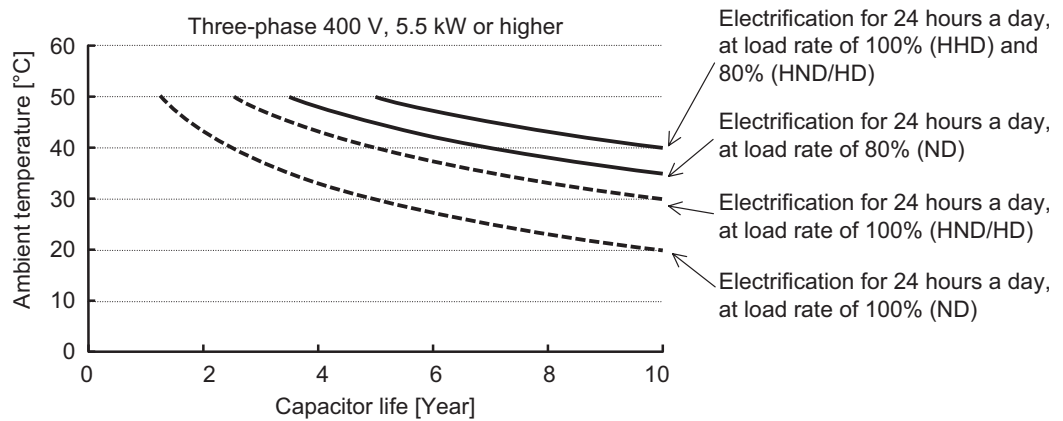
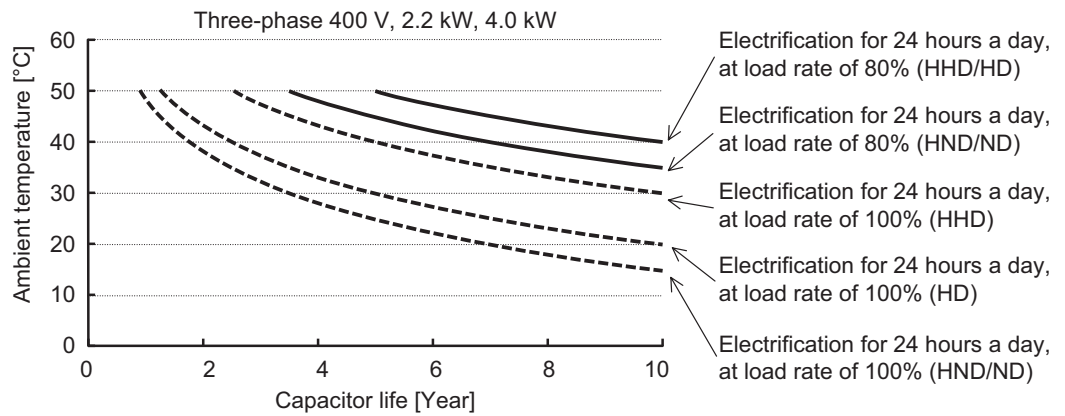
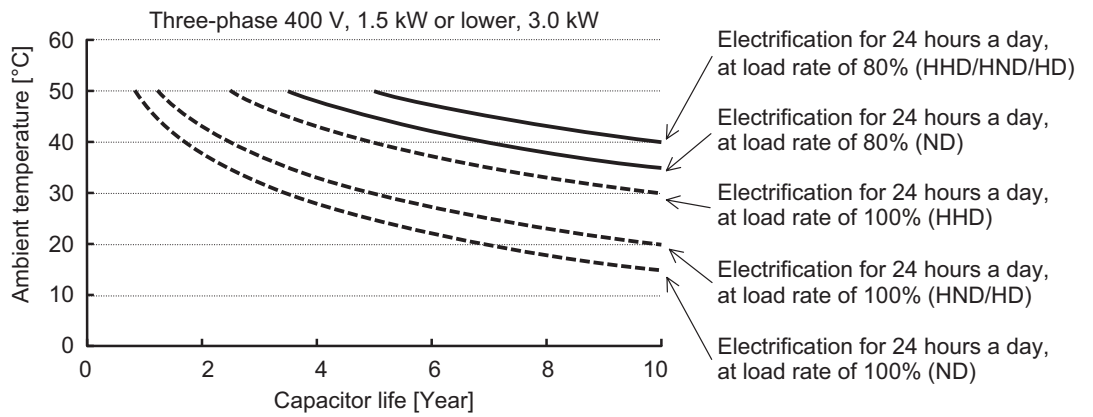

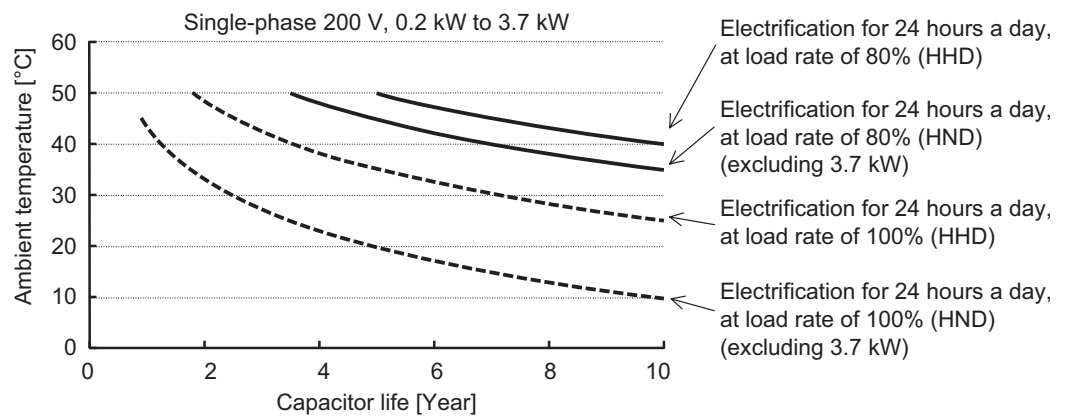

- Note 1.** “Ambient temperature” refers to the temperature measured at a distance of approximately 1 cm from the bottom center of the inverter (atmospheric temperature).  
It refers to an interior temperature if the inverter is stored in a cabinet.
- Note 2.** The smoothing capacitor has a limited life because it is subjected to chemical reaction inside the part and, as a guide, the inverter needs to be replaced once a decade approximately. (This period is an expected design life, and not the guaranteed value.)  
However, if the inverter is used at a high ambient temperature or in a heavy loaded environment, such as at the over-rated current, its life will be significantly shortened.

## A-3 Life Alarm Output

---

The inverter can output an alarm by the self-diagnostic function when the service life of each consumable part incorporated in the inverter (main circuit capacitor, cooling fan, PC board electrolytic capacitor) comes close to the end. Use this as a guide to know the time for the parts replacement.

Note that this alarm is output by the self-diagnosis based on the expected design life (not guaranteed value). It has a margin of error depending on your environment or operation conditions.

For details, refer to *7-8-10 Capacitor Life Warning Signal (WAC)* on page 7-96, *7-8-13 Cooling Fan Life Warning Signal (WAF)* on page 7-99, and *7-8-14 Lifetime Alarm (LIFE)* on page 7-100.

## A-4 Overview of Inverter Selection

### A-4-1 Motor Capacity Selection

Before selecting an inverter, first the motor should be chosen. In selecting the motor, calculate the load inertia appropriate to the application, and then calculate the required capacity and torque.

#### Simplified Selection Method (Required Output Calculation)

This method of calculation helps you select a motor by calculating the output (kW) required by the motor to maintain its steady rotations. To use this method for motor selection, make allowance for the calculated result because it does not include acceleration/deceleration and other transient state calculations. The simplified selection method is suitable for fan, conveyor, mixer and other applications where a constant state continues for a while.

**Note** The simplified selection method cannot be used for the following applications. For these applications, use the detailed selection method.

- Those requiring rapid startup (acceleration).
- Those that frequently repeat run and stop.
- Those that have a large inertia at the power transfer part.
- Those that have an inefficient power transfer part.

#### ● For linear motion: Steady power $P_0$ [kW]

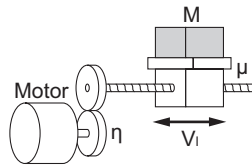

$$P_0 \text{ [kW]} = \frac{\mu \cdot Mg \cdot V_l}{60 \cdot \eta} \times 10^{-3}$$

$\mu$  : Friction coefficient  
 $M$  : Mass of linear motion part [kg]  
 $g$  : Acceleration of gravity ( $g \approx 9.8 \text{ [m/s}^2\text{]}$ )  
 $V_l$  : Speed of linear motion part [m/min]  
 $\eta$  : Efficiency of transfer part ( $\eta \leq 1$ )

**Note** The same calculating formula is applicable to belt conveyors.

#### ● For rotation motion: Steady power $P_0$ [kW]

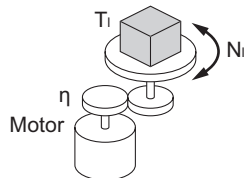

$$P_0 \text{ [kW]} = \frac{2\pi \cdot T_l \cdot N_l}{60 \cdot \eta} \times 10^{-3}$$

$T_l$  : Load torque (Load shaft) [N·m]  
 $N_l$  : Rotation speed of load shaft [r/min]  
 $\eta$  : Efficiency of transfer part ( $\eta \leq 1$ )

#### Detailed Selection Method (RMS Calculation)

This method helps you select a motor by calculating the effective torque and maximum torque values required to achieve a certain pattern of operation for the application. It selects a motor that is optimal for a particular operation pattern.

## ● Calculation of load inertia and motor-shaft conversion inertia

Depending on the type of the motor transfer system, calculate the inertia for all parts and convert it into the motor-shaft inertia.

- Example in hoist application

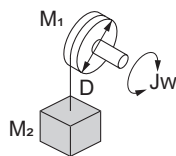

$$\begin{aligned} J_w \text{ [kg}\cdot\text{m}^2] &= J_1 + J_2 \\ &= \left( \frac{M_1 \cdot D^2}{8} + \frac{M_2 \cdot D^2}{4} \right) \times 10^{-6} \end{aligned}$$

$J_w$  : Shaft conversion inertia [kg·m<sup>2</sup>]  
 $J_1$  : Inertia of cylinder (Shaft conversion) [kg·m<sup>2</sup>]  
 $J_2$  : Inertia of workpiece (Shaft conversion) [kg·m<sup>2</sup>]  
 $M_1$  : Mass of cylinder [kg]  
 $M_2$  : Mass of workpiece [kg]  
 $D$  : Diameter of cylinder [mm]

- Example in conveyor application

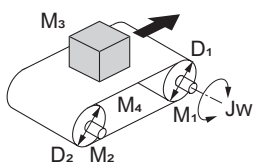

$$\begin{aligned} J_w \text{ [kg}\cdot\text{m}^2] &= J_1 + J_2 + J_3 + J_4 \\ &= \left( \frac{M_1 \cdot D_1^2}{8} + \frac{M_2 \cdot D_2^2}{8} \cdot \frac{D_1^2}{D_2^2} + \frac{M_3 \cdot D_1^2}{4} + \frac{M_4 \cdot D_1^2}{4} \right) \times 10^{-6} \end{aligned}$$

$J_w$  : Shaft conversion inertia (Cylinder-1-shaft conversion) [kg·m<sup>2</sup>]  
 $J_1$  : Inertia of cylinder 1 (Cylinder-1-shaft conversion) [kg·m<sup>2</sup>]  
 $J_2$  : Inertia of cylinder 2 (Cylinder-1-shaft conversion) [kg·m<sup>2</sup>]  
 $J_3$  : Inertia of workpiece (Cylinder-1-shaft conversion) [kg·m<sup>2</sup>]  
 $J_4$  : Inertia of belt (Cylinder-1-shaft conversion) [kg·m<sup>2</sup>]  
 $M_1$  : Mass of cylinder 1 [kg]  
 $M_2$  : Mass of cylinder 2 [kg]  
 $M_3$  : Mass of workpiece [kg]  
 $M_4$  : Mass of belt [kg]  
 $D_1$  : Diameter of cylinder 1 [mm]  
 $D_2$  : Diameter of cylinder 2 [mm]

- Example in roller application

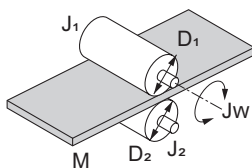

$$J_w \text{ [kg}\cdot\text{m}^2] = J_1 + \left( \frac{D_1^2}{D_2^2} \right) J_2 + \frac{M \cdot D_1^2}{4} \times 10^{-6}$$

$J_w$  : Shaft conversion inertia (Roller-1-shaft conversion) [kg·m<sup>2</sup>]  
 $J_1$  : Inertia of roller 1 (Roller-1-shaft conversion) [kg·m<sup>2</sup>]  
 $J_2$  : Inertia of roller 2 (Roller-2-shaft conversion) [kg·m<sup>2</sup>]  
 $M$  : Mass of workpiece [kg]  
 $D_1$  : Diameter of roller 1 [mm]  
 $D_2$  : Diameter of roller 2 [mm]

- Example of conversion into motor-shaft inertia

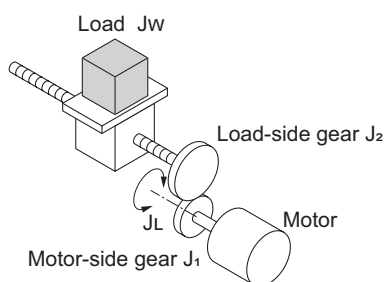

$$J_L \text{ [kg}\cdot\text{m}^2] = J_1 + G^2 (J_2 + J_w)$$

$J_L$  : Motor-shaft conversion inertia [kg·m<sup>2</sup>]  
 $J_w$  : Load inertia (Load-side gear-shaft conversion) [kg·m<sup>2</sup>]  
 $J_1$  : Inertia of motor-side gear [kg·m<sup>2</sup>]  
 $J_2$  : Inertia of load-side gear [kg·m<sup>2</sup>]  
 $Z_1$  : Number of motor-side gear teeth  
 $Z_2$  : Number of load-side gear teeth  
 $G$  : Gear ratio (Speed reduction ratio) =  $Z_1 / Z_2$

● **Calculation of motor-shaft conversion torque and effective torque**

Calculate the acceleration torque from the motor-shaft conversion load inertia, the motor-rotor inertia and the acceleration. Then, calculate the load torque from the external force (gravity and tension) and friction force applied to the load. Finally, combine these calculation results to calculate the torque required for the motor.

- Calculation of acceleration torque ( $T_A$ )

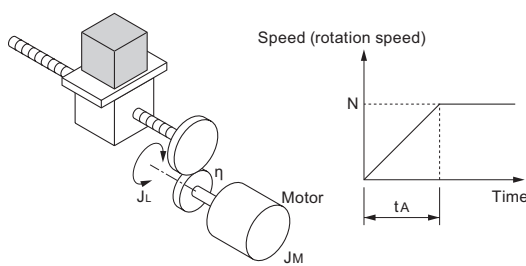

$$T_A[\text{N}\cdot\text{m}] = \frac{2\pi \cdot N}{60 \cdot t_A} \left( J_M + \frac{J_L}{\eta} \right)$$

$T_A$  : Acceleration torque [ $\text{N}\cdot\text{m}$ ]  
 $J_L$  : Motor-shaft conversion load inertia [ $\text{kg}\cdot\text{m}^2$ ]  
 $J_M$  : Motor-rotor inertia [ $\text{kg}\cdot\text{m}^2$ ]  
 $\eta$  : Efficiency of transfer part ( $\eta \leq 1$ )  
 $t_A$  : Acceleration time [s]  
 $N$  : Motor rotation speed [r/min]

- Calculation of motor-shaft conversion load torque ( $T_L$ )

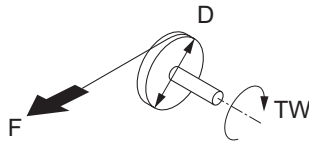

$$T_W[\text{N}\cdot\text{m}] = F \cdot \frac{D}{2} \times 10^{-3}$$

$T_W$  : Load torque (Load-shaft conversion) [ $\text{N}\cdot\text{m}$ ]  
 $F$  : External force [N]  
 $D$  : Diameter of cylinder [mm]

(Generally, the friction force can be calculated as below:)

$$F = \mu M g$$

$\mu$  : Coefficient of friction  
 $M$  : Mass of motion part [kg]  
 $g$  : Acceleration of gravity ( $g \approx 9.8 \text{ [m/s}^2\text{]}$ )

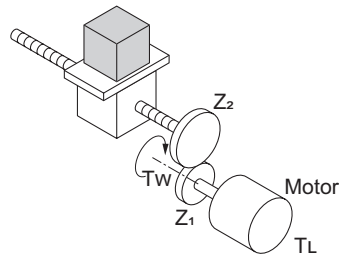

$$T_L[\text{N}\cdot\text{m}] = T_w \cdot \frac{G}{\eta}$$

$T_L$  : Motor-shaft conversion load torque [ $\text{N}\cdot\text{m}$ ]  
 $T_w$  : Load torque (Load-shaft conversion) [ $\text{N}\cdot\text{m}$ ]  
 $Z_1$  : Number of motor-side gear teeth  
 $Z_2$  : Number of load-side gear teeth  
 $G$  : Gear ratio (Speed reduction ratio) =  $Z_1 / Z_2$

- Calculation of combined torque and effective torque



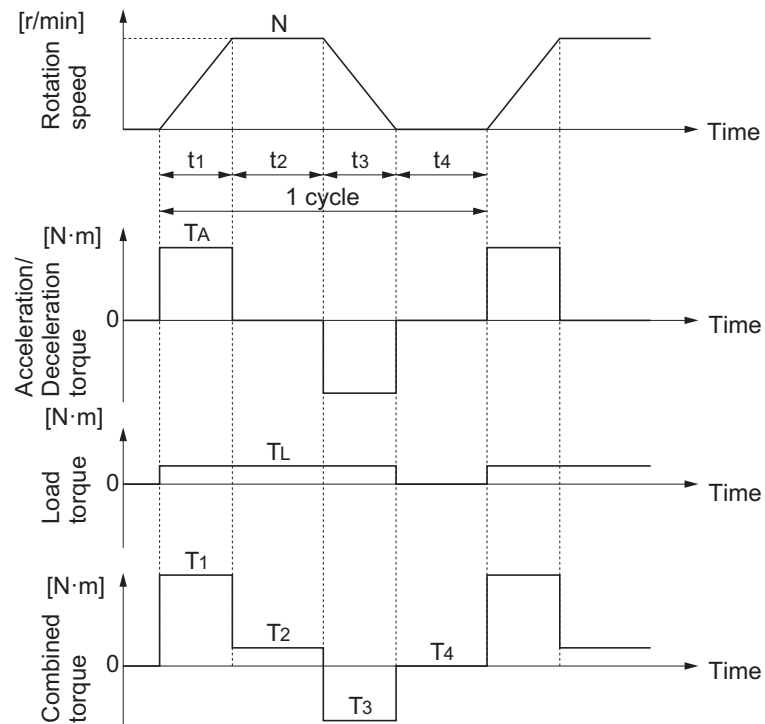

- Effective torque  $T_{RMS}$  [N·m]

$$= \sqrt{\frac{\sum(T_i^2 \cdot t_i)}{\sum t_i}}$$

$$= \sqrt{\frac{T_1^2 \cdot t_1 + T_2^2 \cdot t_2 + T_3^2 \cdot t_3 + T_4^2 \cdot t_4}{t_1 + t_2 + t_3 + t_4}}$$

- Maximum torque  $T_{MAX}$  [N · m] =  $T_1 = T_A + T_L$

### ● Motor selection

Based on the above calculation results, select the motor capacity by using the following formulae. Select the larger of the two calculated values as the motor capacity. Also, when selecting a motor, take into consideration the errors in calculation and modeling. Select a motor whose capacity is at least approximately 20% larger.

- Motor capacity conversion to effective torque

$$\text{Motor capacity [kW]} = \frac{2\pi \cdot T_{RMS} \cdot N}{60} \times 10^{-3} \quad N : \text{Maximum rotation speed [r/min]}$$

- Motor capacity required for maximum torque output

$$\text{Motor capacity [kW]} = \frac{2\pi \cdot T_{MAX} \cdot N}{60 \times 1.5} \times 10^{-3} \quad N : \text{Maximum rotation speed [r/min]}$$

**Note** The above calculation formulae assume that the maximum motor torque is 150% of the rated torque.

## A-4-2 Inverter Capacity Selection

Select an inverter that can be used with the motor you selected based on the result of motor capacity selection.

Basically, select an inverter which fits the maximum applicable motor capacity of the selected motor. After selecting an inverter, check if it meets both of the following conditions. If not, select an inverter with one size larger in capacity and check again.

**Rated motor current  $\leq$  Rated output current of inverter**

**Max. continuous torque output time for application  $\leq$  1 min**

**Note 1.** In the light load mode, the overload capacity of the inverter is 150% of the rated torque for 5 seconds. Use the 5-seconds rating when determining the maximum continuous torque.

**Note 2.** If you want to use 0 Hz sensorless vector control, need a holding torque at a rotation speed of 0 (r/min), or frequently require 150% of the rated torque or more, use an inverter with one size larger in capacity than the one selected by the above method.

### A-4-3 Overview of Braking Resistor Selection

#### Requirement of Braking Resistor

If the regenerative energy generated in deceleration or descent in an application is too large, the main circuit voltage in the inverter may increase, which results in damage to the inverter.

Normally, the inverter has a built-in overvoltage protection function, which detects an overvoltage (0 V) in the main circuit to prevent inverter damage. However, because it detects a fault to stop the motor, stable and continuous operation will be prevented.

Therefore, you need to use one or more braking resistors/regenerative braking units to absorb this regenerative energy outside the inverter.

#### ● What is regenerative energy?

The load connected to a motor has kinetic energy when rotating, and potential energy when it is subject to the gravity. When the motor decelerates, or when the load descends, the energy is fed back to an inverter. This phenomenon is known as regeneration, and the energy is called regenerative energy.

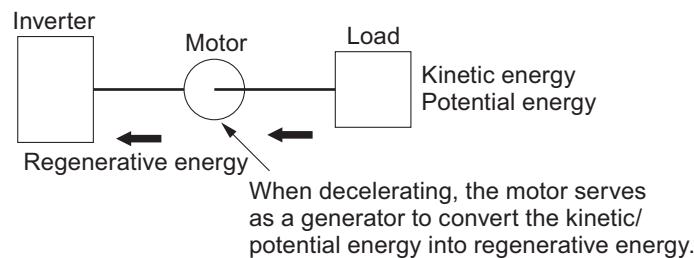

#### ● Preventing an overvoltage (0 V) in the main circuit without use of braking resistors

The following are methods to prevent the occurrence of an overvoltage (0 V) in the main circuit without connection of braking resistors.

Since these methods prolong the deceleration time, check that the selected method will not cause application problems.

- Enable the overvoltage suppression function during deceleration  
The overvoltage suppression function during deceleration is enabled by default.

It automatically increases the deceleration time to prevent the occurrence of an overvoltage in the main circuit.

- Set a longer deceleration time

Increase the deceleration time to prevent the occurrence of an overvoltage in the main circuit. This decreases the amount of regenerative energy per unit time.

- Select free-run stop

This prevents the regenerative energy from being fed back to the inverter.

## Simplified Braking Resistor Selection

This is a simple method to select an appropriate braking resistor based on the percentage of the time in which regenerative energy is produced in a normal operation pattern.

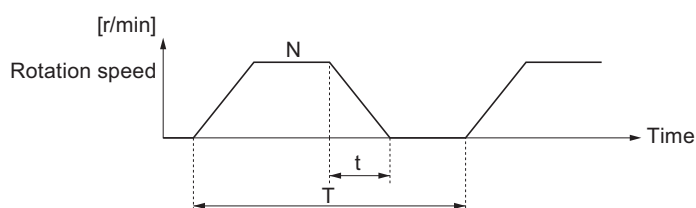

$$\text{Usage rate [\%ED]} = 100 \times t / T$$

t : Deceleration time (regenerative time) [s]  
T : 1cycle operation time [s]

All models of the 3G3M1 Series Inverter have built-in regenerative braking circuit.

Select a braking resistor based on the usage rate calculated from the operation pattern.

Connect a braking resistor suitable for your inverter according to the braking resistor list provided in the inverter manual/catalog.

## Detailed Braking Resistor Selection

When the usage rate of the braking resistor selected on the previous section exceeds 10% ED, or when an extremely large braking torque is required, use the method below to calculate a regenerative energy and make your selection.

### ● Calculation of Required Braking Resistance

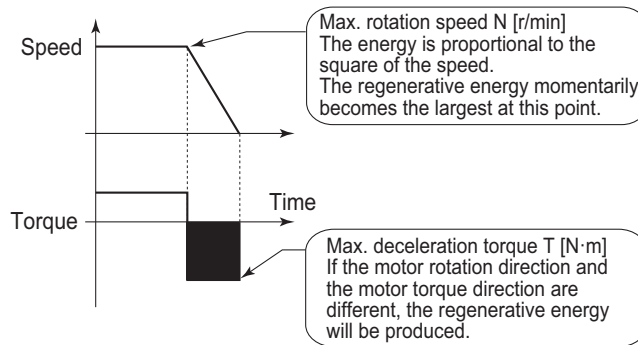

$$\text{Resistance of braking resistor : } R \leq \frac{60 \times V^2}{2\pi \cdot (T - 0.2 \times T_m) \cdot N}$$

- $V$  : 200-V class inverter 362.5 [V]  
400-V class inverter 725 [V]
- $T$  : Maximum braking torque [N·m]
- $T_m$  : Motor rating torque [N·m]
- $N$  : Maximum rotation speed [r/min]

**Note** Calculate a braking torque according to Inverter Capacity Selection in the Motor Capacity Selection section.

### ● Calculation of average regenerative energy

Regenerative energy is produced when the motor rotation and the torque are opposite in direction. Use the following formula to calculate the regenerative energy for each period in a cycle.

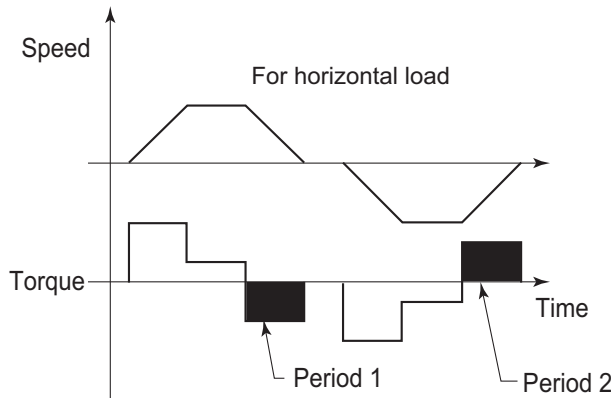

$$P_i = N \times T \times t \times 1.047 \times 10^{-1}$$

- $P_i$  : Regenerative energy in Period  $i$  [J]
- $N$  : Motor rotation speed [r/min]  
When the number of rotations changes, take an average value.

ex. For linear deceleration  
 $(N_{\max} + N_{\min}) / 2$

- $T$  : Deceleration torque [N·m]
- $t$  : Deceleration time [s]

For the average regenerative energy, calculate the time average by adding the regenerative energy for all periods in a cycle and dividing it by the cycle time, as shown below.

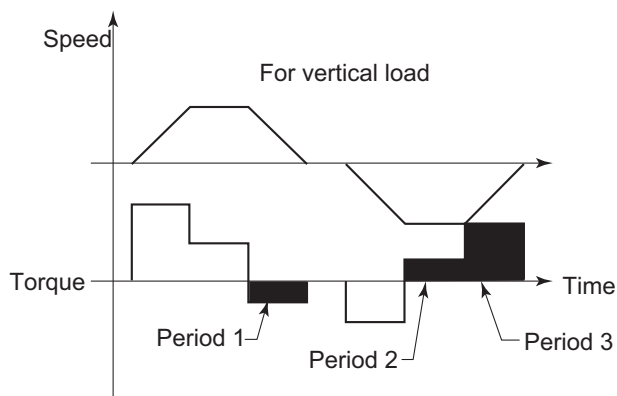

Average regenerative energy [W]

$$= \frac{(P1+P2 \dots +Pi)[J]}{1 \text{ cycle time [s]}}$$

**Note 1.** For Speed, the forward rotation direction is indicated as positive. For Torque, the torque in the forward rotation direction is indicated as positive.

**Note 2.** Calculate a braking torque according to Inverter Capacity Selection in the Motor Capacity Selection section.

### ● Braking Resistor Selection

Select a braking resistor from the required braking resistance and the average regenerative energy obtained in this calculation.

- Required braking resistance  $\geq$  Resistance of braking resistor  $\geq$  Min. connection resistance of inverter
- Average regenerative energy  $\leq$  Resistance capacity of braking resistor

**Note 1.** Connecting a braking resistor whose resistance is less than the minimum connection resistance value of the inverter results in damage to the internal braking transistor. If the required braking resistance is less than the minimum connection resistance, change the inverter to one having a larger capacity and ensure that the required braking resistance is not less than the minimum connection resistance.

**Note 2.** Make allowance for the resistance capacity of the braking resistor. Select a braking resistor whose capacity is at least 20% larger than the calculated value. Otherwise, it may be overheated.





**OMRON Corporation Industrial Automation Company**

**Kyoto, JAPAN**

**Contact : [www.ia.omron.com](http://www.ia.omron.com)**

**Regional Headquarters**

**OMRON EUROPE B.V.**

Wegalaan 67-69, 2132 JD Hoofddorp  
The Netherlands

Tel: (31) 2356-81-300 Fax: (31) 2356-81-388

**OMRON ASIA PACIFIC PTE. LTD.**

438B Alexandra Road, #08-01/02 Alexandra  
Technopark, Singapore 119968

Tel: (65) 6835-3011 Fax: (65) 6835-2711

**OMRON ELECTRONICS LLC**

2895 Greenspoint Parkway, Suite 200  
Hoffman Estates, IL 60169 U.S.A.

Tel: (1) 847-843-7900 Fax: (1) 847-843-7787

**OMRON (CHINA) CO., LTD.**

Room 2211, Bank of China Tower,  
200 Yin Cheng Zhong Road,  
PuDong New Area, Shanghai, 200120, China

Tel: (86) 21-5037-2222 Fax: (86) 21-5037-2200

**Authorized Distributor:**

©OMRON Corporation 2022-2023 All Rights Reserved.  
In the interest of product improvement,  
specifications are subject to change without notice.

**Cat. No. I669-E1-03** 0323